

ARMY TM 9-2320-365-10
AIR FORCE T.O. 36A12-1B-1095-1

**OPERATOR'S INSTRUCTIONS
MANUAL
M1078 SERIES, 2-1/2 TON, 4x4,
LIGHT MEDIUM TACTICAL
VEHICLES (LMTV)**

MODEL	NSN	EIC
TRK, CAR., LMTV, M1078		
W/WN	2320-01-360-1898	BHH
W/O WN	2320-01-354-3385	BHD
TRK, VAN., LMTV, M1079		
W/WN	2320-01-360-1891	BHG
W/O WN	2320-01-354-3384	BHE
TRK, CHAS, LMTV, M1080	2320-01-353-9098	BHC
TRK, CAR., LMTV, AIR DROP M1081		
W/WN	2320-01-360-1899	BHJ
W/O WN	2320-01-355-3064	BHF

TABLE OF
CONTENTS ii

HOW TO USE
THIS MANUAL v

EQUIPMENT
DESCRIPTION 1-10

DESCRIPTION AND USE OF
OPERATOR'S CONTROLS
AND INDICATORS 2-3

PREVENTIVE
MAINTENANCE CHECKS
AND SERVICES
(PMCS) 2-30

OPERATION UNDER
USUAL CONDITIONS 2-126

OPERATION UNDER
UNUSUAL CONDITIONS
2-292

TROUBLESHOOTING
INSTRUCTIONS 3-2

MAINTENANCE
PROCEDURES 3-72

LUBRICATION
INSTRUCTIONS F-1

ALPHABETICAL INDEX
INDEX-1

DISTRIBUTION STATEMENT A. Approved for public release; distribution is unlimited.

**HEADQUARTERS, DEPARTMENTS OF THE
ARMY AND THE AIR FORCE**

JUNE 1998

WARNING SUMMARY

WARNING

CARBON MONOXIDE (EXHAUST GAS) CAN KILL YOU.

Carbon monoxide is a colorless, odorless, **DEADLY POISONOUS** gas and when breathed deprives body of oxygen and causes **SUFFOCATION**. Breathing air with carbon monoxide produces symptoms of headache, dizziness, loss of muscular control, a sleepy feeling, and coma. Permanent **BRAIN DAMAGE** or **DEATH** can result from severe exposure.

The following precautions **MUST** be followed to ensure personnel are safe whenever any type of personnel heater or engine is operated for any purpose. Failure to comply may result in serious injury or death to personnel.

DO NOT operate heater or engine in an enclosed area without adequate ventilation.

DO NOT drive any vehicle with inspection plates, cover plates, or engine compartment covers removed unless necessary for maintenance purposes.

NEVER sleep in a vehicle when heater is operating or the engine is idling.

BE ALERT at all times during vehicle operation for exhaust odors and exposure symptoms. If either is present, **IMMEDIATELY VENTILATE** personnel compartments. Treatment of affected personnel shall be: exposure to fresh air; keep warm; **DO NOT PERMIT PHYSICAL EXERCISE**. If necessary, give cardiopulmonary resuscitation, as described in FM 21-11, and get immediate medical attention. Failure to comply may result in serious injury or death to personnel.

THE BEST DEFENSE AGAINST CARBON MONOXIDE POISONING IS GOOD VENTILATION.

WARNING

CARBON MONOXIDE (EXHAUST GAS) CAN KILL YOU.

DO NOT operate engine in an enclosed area without adequate ventilation. **NEVER** sleep in a vehicle when heater is operating or the engine is idling. Failure to comply may result in serious injury or death to personnel. ■

WARNING SUMMARY (CONT)

WARNING

Nuclear, Biological, or Chemical (NBC) contaminated air filters must be handled and disposed of only by authorized and trained personnel. The unit commander or senior officer in charge of maintenance personnel must ensure that prescribed protective clothing (FM 3-4) is used, and prescribed safety measures and decontamination procedures (FM 3-5 and TB 700-4) are followed. The unit standard operating procedures are responsible for final disposal of contaminated air filters. Failure to comply may result in serious injury or death to personnel.

WARNING

Adhesives, solvents, and sealing compounds can burn easily, can give off harmful vapors, and are harmful to skin and clothing. Keep away from open fire and use in well-ventilated area. If adhesive, solvent, or sealing compound gets on skin or clothing, wash immediately with soap and water. Failure to comply may result in serious injury to personnel.

WARNING

When required to remain inside the vehicle during extreme heat, occupants should follow the water intake, work/rest cycle, and other heat stress preventive medicine measures contained in FM 21-10 Field Hygiene and Sanitation, and FM 21-11 First Aid for Soldiers. Failure to comply may result in serious injury or death to personnel.

WARNING

Do not touch extremely cold metal (below -26°F, -32°C). Bare skin may freeze to cold metal. Failure to comply may result in injury to personnel.

WARNING

Pressure in coolant reservoir must be released before removing cap. Failure to comply may result in injury to personnel.

WARNING

Never raise cab while occupied or when parked uphill on a steep grade. Failure to comply may result in serious injury or death to personnel.

WARNING

Cab hydraulic latch must be locked before driving vehicle. Failure to comply may result in serious injury or death to personnel or damage to equipment.

WARNING

Do not pull seat belt more than 1 in. (2.54 cm) away from shoulder. Seat belt will not be effective if accident occurs. Failure to comply may result in serious injury or death to personnel.

WARNING

Vehicle must be secure. Chock tires when stopped on incline. Vehicle may roll downhill. Failure to comply may result in serious injury or death to personnel or damage to equipment.

WARNING

Ensure vehicle is parked on level ground before changing flat tire. Vehicle may roll. Failure to comply may result in serious injury or death to personnel.

WARNING

Both suspension compression plates must be installed on axle studs. Failure to comply may result in serious injury or death to personnel.

WARNING

Engine compartment and accessories may be extremely hot when engine is running or has been running recently. Use caution around engine when cab is raised. Failure to comply may result in injury to personnel.

WARNING SUMMARY (CONT)

WARNING

Engine compartment contains a partially exposed fan blade. Extreme care should be taken when working in engine compartment. Failure to comply may result in injury to personnel.

WARNING

Cargo cover weighs approximately 60 lbs (27 kgs). An assistant is required to lift cargo cover. Failure to comply may result in injury to personnel or damage to equipment.

WARNING

Ensure engine oil is cool before performing any maintenance. Failure to comply may result in serious injury or death to personnel.

WARNING

Ensure both doors are securely closed before cab is raised/lowered. Do not allow personnel near cab when cab is being raised/lowered. Cab doors could open. Failure to comply may result in serious injury or death to personnel or damage to equipment.

WARNING

Ensure safety strap is fastened across back and front of vehicle before transporting troops. Failure to comply may result in serious injury or death to personnel.

WARNING

Data and instruction plates given below must be followed at all times to safely operate vehicle. Failure to comply may result in injury to personnel or damage to equipment.

WARNING

Extreme care should be taken when removing coolant fill cap if temperature gage reads above 180°F (80°C). Contact with steam or hot coolant under pressure may result. Failure to comply may result in injury to personnel.

WARNING

Tire weighs approximately 350 lbs (159 kgs). If treads of tire catch on tool box during lowering, raise tire and pull tire away from tool box and continue lowering. Use extreme care when lowering or handling tire. Failure to comply may result in injury to personnel.

WARNING

Tire weighs approximately 350 lbs (159 kgs). Use extreme care when handling tire. Failure to comply may result in injury to personnel.

WARNING

Place hydraulic jack on flat surface. Do not allow personnel under vehicle when jacking. Failure to comply may result in serious injury or death to personnel.

WARNING

Handle tire with care. Tire may have exposed broken metal cords or sharp debris in it. Failure to comply may result in injury to personnel.

WARNING

Use caution when inflating tire. Overinflation may cause tire to blow apart. Failure to comply may result in serious injury or death to personnel or damage to equipment.

WARNING

Wheels must be chocked and service brakes applied before parking brake is released. Vehicle may roll if wheels are not chocked. Failure to comply may result in serious injury or death to personnel.

WARNING

All cleaning procedures must be accomplished in well-ventilated areas. Failure to comply may result in injury to personnel or damage to equipment.

WARNING SUMMARY (CONT)

WARNING

Protective gloves, clothing, and/or respiratory equipment must be worn whenever caustic, toxic, or flammable cleaning solutions are used. Failure to comply may result in injury to personnel or damage to equipment.

WARNING

A fire extinguisher must be available and ready during all cleaning operations involving solvents. Failure to comply may result in injury to personnel or damage to equipment.

WARNING

Manifold operator must stand near hydraulic manifold and observe spare tire. Guide person must stand to the right front of vehicle, well clear of spare tire. Failure to comply may result in serious injury or death to personnel.

WARNING

- Cab roof weighs approximately 130 lbs (59 kgs). Use care when handling cab roof. Failure to comply may result in injury to personnel or damage to equipment.

WARNING

Vehicle must not be operated until rear panel and side panels are raised and properly secured. Failure to comply may result in serious injury or death to personnel or damage to equipment.

WARNING

Manifold operator must stand near hydraulic manifold and observe spare tire while it is being lowered from cargo bed. Spare tire will gain momentum as it is being lowered. Failure to comply may result in serious injury or death to personnel.

WARNING

Ensure tires have correct tire pressure for terrain conditions and driving speed (refer to Table 3-3). Failure to comply may result in serious injury or death to personnel.

WARNING

Dry Cleaning Solvent (P-D-680) is TOXIC and flammable. Wear protective goggles and gloves; use only in well-ventilated area; avoid contact with skin, eyes, and clothes, and do not breath vapors. Keep away from heat or flame. Never smoke when using Dry Cleaning Solvent; the flashpoint for Type I Dry Cleaning Solvent is 100 °F (38 °C) and for Type II is 138 °F (50 °C). Failure to comply may result in serious injury or death to personnel.

WARNING

If personnel become dizzy while using cleaning Dry Cleaning Solvent, immediately get fresh air and medical help. If Dry Cleaning Solvent contacts skin or clothes, flush with cold water. If Dry Cleaning Solvent contacts eyes, immediately flush eyes with water and get medical attention. Failure to comply may result in serious injury to personnel.

WARNING

Hydraulic fluid (MIL-H-5606A) is TOXIC. Wear protective goggles and gloves; use only in well ventilated area; avoid contact with skin, eyes, and clothes. Skin and clothing that come in contact with hydraulic fluid should be washed immediately. Saturated clothing should be removed immediately. Failure to comply may result in injury to personnel.

WARNING

Lead-acid battery gases can explode. Do not smoke, have open flames, or make sparks around a battery, especially if caps are off. Battery may give off gas which can explode. Failure to comply may result in serious injury or death to personnel.

WARNING

Do not back up vehicle without an assistant. Operator has limited vision while backing vehicle. Failure to comply may result in serious injury or death to personnel or damage to equipment.

WARNING

Remove rings, bracelets, wristwatches, neck chains, and any other jewelry before working around the vehicle. Jewelry may catch on equipment or may short across an electrical circuit or battery terminal. Failure to comply may result in serious injury or death to personnel.

WARNING SUMMARY (CONT)

WARNING

■ Do not smoke, have open flame, or make sparks near batteries when starting vehicle. Batteries can explode. Failure to comply may result in serious injury or death to personnel.

WARNING

Ensure master power switch on both vehicles are turned to off before connecting NATO power cable. Vehicles must not touch each other. Failure to comply may result in serious injury or death to personnel.

WARNING

Engine dipstick is located close to starter solenoid connectors which contain 24 vdc and high amperage. Use caution removing/installing engine dipstick to prevent shorting across starter solenoids when checking engine oil level. Failure to comply may result in serious injury or death to personnel or damage to equipment.

WARNING

Diesel fuel is flammable. Do not fill fuel tank with engine running, while smoking, or when near an open flame. Never overfill the tank or spill fuel. If fuel is spilled, clean it up immediately. Failure to comply may result in serious injury or death to personnel.

WARNING

Do not perform fuel/water separator checks, inspections, or draining while smoking, or when near fire or sparks. Fuel could ignite. Failure to comply may result in serious injury or death to personnel.



WARNING

Diesel fuel or gasoline must never be used for cleaning. Failure to comply may result in injury to personnel or damage to equipment.

WARNING

Applying brakes on slick surfaces may cause vehicle to skid. Apply brake pedal very lightly. Failure to comply may result in serious injury or death to personnel.

WARNING

Operating in water or mud causes brake linings to get wet and can impair vehicle braking. Dry brakes by driving vehicle about 500 ft (153 m) while applying service brakes often. If adequate braking is not restored by drying brakes, notify Unit Maintenance. Failure to comply may result in injury to personnel or damage to equipment.

WARNING

Rear axle service brakes will not operate if REAR BRAKE AIR pressure gage reads below 65 psi. Rear axle braking will be provided by rear spring brakes for a limited time. Allow greater stopping distance. Discontinue vehicle operation as soon as possible. Failure to comply may result in serious injury or death to personnel.

WARNING

Front axle service brakes will not operate if FRONT BRAKE AIR pressure gage reads below 65 psi (448 kPa). Allow greater stopping distance. Discontinue vehicle operation as soon as possible. Failure to comply may result in serious injury or death to personnel.

WARNING SUMMARY (CONT)

WARNING

Notify Unit Maintenance that lugnuts need to be tightened to 415-475 lb-ft (563-644 N·m) as soon as possible. Tire may come loose if lugnuts are not tightened to proper torque. Failure to comply may result in serious injury or death to personnel.

WARNING

Do not exceed maximum vehicle speed and grade limitations during normal operations. Do not exceed maximum approach or departure angles or ford water greater than maximum depth. Failure to comply may result in serious injury or death to personnel.

WARNING

Bridges along your route may be marked with a class number. The bridge class number shows the safe capacity of the bridge. If the bridge class number on your vehicle is equal to or less than the bridge class number, the bridge will hold your vehicle. If the bridge class number on your vehicle is greater than the bridge class number; **DO NOT CROSS BRIDGE**. Failure to comply may result in serious injury or death to personnel or damage to equipment.

WARNING

Do not use **HAND THROTTLE** lever while driving vehicle. The **HAND THROTTLE** lever is not to be used as a cruise control. Failure to comply may result in serious injury or death to personnel or damage to equipment.

WARNING

Vehicle speed should be reduced to 5-10 mph (8-16 km/h) during blackout conditions. Failure to comply may result in serious injury or death to personnel.

WARNING

Do not press brake pedal hard three or four times in a row. Air supply will be used up and service brakes will not work until air pressure builds up again. Do not operate vehicle until **FRONT** and **REAR BRAKE AIR** pressure reaches at least 100 psi (690 kPa).
■ Failure to comply may result in serious injury or death to personnel or damage to equipment.

WARNING

Transmission incorporates a hold feature to prohibit upshifting above selected gear during normal driving. However, during downhill operation, transmission may upshift above selected gear. On downgrades, vehicle speed may need to be restricted by using service brakes. Failure to comply may result in serious injury or death to personnel or damage to equipment.

WARNING

Avoid driving diagonally across a hill. Vehicle could roll over. Failure to comply may result in serious injury or death to personnel or damage to equipment.

WARNING

Do not straddle or drive on sides of sand mounds. Loose sand will not support vehicle on steep slopes. Avoid driving diagonally across a hill. Vehicle may roll over. Failure to comply may result in serious injury or death to personnel or damage to equipment.

WARNING

Do not leave vehicle at any time without first returning **HAND THROTTLE** lever to full down position and placing transmission to Neutral. Failure to comply may result in serious injury or death to personnel.

WARNING

Brake pedal must be held down and personnel kept clear of vehicle path while WTEC II Transmission ECU Pushbutton Shift Selector (TEPSS) or WTEC III Transmission Pushbutton Shift Selector (TPSS) is in DRIVE. Transmission will sometimes shift into third gear when in cold operation. Transmission will shift into second when engine reaches operating temperature (165° F (74°C) on WATER TEMP gage) causing the vehicle to lurch or move forward. The vehicle cannot move if SYSTEM PARK is engaged and the brake pedal is held down. Failure to comply may result in serious injury or death to personnel.

WARNING

Engine must be shut down prior to exhaust restrictor removal. Failure to comply may result in serious injury or death to personnel.

WARNING SUMMARY (CONT)

WARNING

Do not handle exhaust restrictor or tailpipe with bare hands. Failure to comply may result in injury to personnel.

WARNING

Towing vehicle and disabled vehicle must have parking brakes applied before connecting/disconnecting towbar. Failure to comply may cause vehicles to roll into each other and may result in serious injury or death to personnel or damage to equipment.

WARNING

- Towbar weighs approximately 150 lbs (68 kgs) and requires two or more personnel to carry. Failure to comply may result in injury to personnel.

WARNING

Do not place hands near pintle hook when connecting/disconnecting towbar with pintle hook. Failure to comply may result in injury to personnel.

WARNING

Personnel must not occupy towed vehicle during towing operation. vehicle may become disconnected while being towed. Failure to comply may result in serious injury or death to personnel.

WARNING

Ground guide is required to guide vehicle backing up. Failure to comply may result in injury to personnel or damage to equipment.

WARNING

Wear heavy leather-palmed work gloves when handling cable. Cables can become frayed or contain broken wires. Never let moving cable slide through hands, even when wearing gloves. Failure to comply may result in serious injury or death to personnel.

WARNING

There must always be at least five wraps of cable on 11K Self-Recovery Winch (SRW). If load is applied with less than five wraps of cable on 11K SRW, cable may come loose on drum and result in serious injury or death to personnel.

WARNING

Keep all personnel clear of area when tension is on cable. Failure to comply may result in serious injury or death to personnel.

WARNING

Ensure line pull does not exceed capacity of 11K Self-Recovery Winch (SRW). Failure to comply may result in serious injury or death to personnel.

WARNING

Use care when removing debris from engine fan. Engine components will be hot. Failure to comply may result in injury to personnel.

WARNING

Ground rod must be driven into ground 18-24 in. (46-61 cm) and ground cable connected to the chassis before power can be taken from outside source or equipment operated inside van. Failure to comply may result in serious injury or death to personnel or damage to equipment.

WARNING SUMMARY (CONT)

WARNING

- Cargo bed is approximately 5 ft (1.5 m) above ground level. Use care during any Light Material Handling Crane (LMHC) operation. Failure to comply may result in serious injury or death to personnel.

WARNING

Ensure that wheels are chocked prior to setting up Light Material Handling Crane (LMHC). Failure to comply may result in injury to personnel.

WARNING

Power cable must be connected to Light Material Handling Crane (LMHC) before being connected to circuit breaker box. Failure to comply may result in serious injury or death to personnel.

WARNING

Ensure that engine is shut down before connecting power cable at vehicle NATO connector. Failure to comply may result in serious injury or death to personnel.

WARNING

Determine required Light Material Handling Crane (LMHC) settings prior to raising boom. Failure to comply may result in injury to personnel or damage to equipment.

WARNING

Ensure there are at least two wraps of cable on hoist drum at all times. Cable could come off hoist drum while load is being lifted. Failure to comply may result in injury to personnel or damage to equipment.

WARNING

- Ensure that engine is shut down before disconnecting circuit breaker box NATO connector at vehicle NATO connector. Failure to comply may result in serious injury or death to personnel.

WARNING

Ensure that ground cable terminal makes good metal-to-metal contact with bare metal on van body. If required, scrape contact area clean of dirt, paint, or rust. Failure to comply may result in serious injury or death to personnel or damage to equipment.

WARNING

Use caution when entering or leaving van. Failure to comply may result in serious injury or death to personnel.

WARNING

Power source must be turned off before disconnecting power cable. Failure to comply may result in injury to personnel or damage to equipment.

WARNING

Ensure that engine is not running before disconnecting circuit breaker box NATO connector from vehicle NATO connector. Failure to comply may result in injury to personnel.

WARNING

Light Material Handling Crane (LMHC) boom and winch weighs approximately 110 lbs (50 kgs). The aid of an assistant is required to remove LMHC boom and winch. Failure to comply may result in injury to personnel.

WARNING

Light Material Handling Crane (LMHC) mast weighs approximately 110 lbs (50 kgs). Use the aid of an assistant to remove mast from cargo bed pocket. Failure to comply may result in injury to personnel.

WARNING

Light Material Handling Crane (LMHC) boom and winch weighs approximately 110 lbs (50 kg). The aid of an assistant is required to install boom and winch. Failure to comply may result in injury to personnel.

WARNING SUMMARY (CONT)

WARNING

Ensure that engine is not running before disconnecting circuit breaker box NATO connector from vehicle NATO connector. Failure to comply may result in injury to personnel.

WARNING

- Heavy objects/loads, such as tool boxes and heavy parts, must always be carried on the floor with the weight distributed as equally as possible between left and right sides of M1079 van. Failure to comply decreases the stability of the M1079 van and will increase the likelihood of a rollover.
- Heavy cabinets must always be mounted as low as possible with the weight distributed as equally as possible between left and right sides of M1079 van. Remember to consider the weight of the items that will be stored in the cabinets. Failure to comply decreases the stability of the M1079 van and will increase the likelihood of a rollover.
- Always keep in mind, when placing items inside the M1079 van, that heavier items must always be positioned as low as possible and the weight distributed as equally as possible between left and right sides of M1079 van. Failure to comply decreases the stability of the M1079 van and will increase the likelihood of a rollover.

WARNING

When operating vehicle in snowy or icy conditions, apply the brake pedal momentarily, every few miles. This will ensure that brake linings do not become encrusted with snow or ice. Failure to comply may result in injury to personnel or damage to equipment.

WARNING

Do not change tire pressure with tire chains installed. Changing tire pressure with tire chains installed could result in chain slippage. Failure to comply may result in serious injury to personnel or damage to equipment.

WARNING

DO NOT flat tow a fully loaded MTV and trailer combination. The MTV wrecker towbar can be damaged if weight capacity is exceeded. Failure to comply may result in serious injury or death to personnel or damage to equipment.

WARNING

When towing a vehicle with nonfunctional brakes, use extreme caution and reduce/adjust speed accordingly. Failure to comply may result in serious injury or death to personnel or damage to equipment.

WARNING

Vehicle Operator and all crew members must wear properly fitted and approved hearing protection devices when operating the M1079 Van at speeds of 50 MPH (80 km/h) and above. Failure to comply may result in injury to personnel.

WARNING

All personnel working within 12 ft (3.5 m) of an operating M1079 Van must wear properly fitted and approved hearing protection devices. Failure to comply may result in injury to personnel.

WARNING

Personnel firing the M240/M2HB machine gun or Mark 19 grenade launcher from an FMTV vehicle during training exercises must be wearing properly fitted and approved hearing protection devices. Failure to comply may result in injury to personnel.

WARNING

All personnel within 180 ft (55 m) of weapons being fired from an FMTV vehicle during training exercises must be wearing properly fitted and approved hearing protection devices. Failure to comply may result in injury to personnel.

WARNING

When mission requires the vehicle Operator and crew to remain in a stationary FMTV vehicle with the engine running in outside temperatures above 90°F (32°C), vehicle Operator and crew must observe proper safety precautions to prevent heat stress injury. Refer to FM 21-10 Field Hygiene and Sanitation, and FM 21-11 First Aid for Soldiers for proper precautions and preventive measures. Failure to comply may result in injury to personnel.

WARNING SUMMARY (CONT)

WARNING

When mission requires the vehicle Operator and crew to operate the FMTV vehicle in outside temperatures above 90°F (32°C) with the windows closed, vehicle Operator and crew must observe proper safety precautions to prevent heat stress injury. Refer to FM 21-10 Field Hygiene and Sanitation, and FM 21-11 First Aid for Soldiers for proper precautions and preventive measures. Failure to comply may result in injury to personnel.

**CHANGE
NO. 2**

**HEADQUARTERS
DEPARTMENTS OF THE ARMY
AND THE AIR FORCE
Washington, D.C., 20 August 2005**

**OPERATOR'S INSTRUCTIONS MANUAL
M1078 SERIES, 2-1/2-TON, 4x4,
LIGHT MEDIUM TACTICAL VEHICLE (LMTV)**

TM 9-2320-365-10, 17 June 1998, is changed as follows:


1. Remove old pages and insert new pages as indicated below.
2. New or changed material is indicated by a vertical bar in the outer margin of the page.
3. Added or revised illustrations are indicated by a vertical bar adjacent to the illustration.

Remove Pages	Insert Pages	Remove Pages	Insert Pages
A and B	A and B	3-39 and 3-40	3-39 and 3-40
none	C/(D Blank)	none	3-66.1/(3-66.2 Blank)
none	Change 2 Authentication Sheet	3-67 and 3-68	3-67 and 3-68
i and ii	i and ii	none	3-68.1/(3-68.2 Blank)
1-21 thru 1-30	1-21 thru 1-30	3-69 thru 3-70.2	3-69 thru 3-70.2
2-9 and 2-10	2-9 and 2-10	3-70.11 and 3-70.12	3-70.11 and 3-70.12
2-33 thru 2-36	2-33 thru 2-36	none	3-70.13 thru 3-70.20
none	2-36.1/(2-36.2 Blank)	3-71 and 3-72	3-71 and 3-72
2-39 and 2-40	2-39 and 2-40	3-77 and 3-78	3-77 and 3-78
2-55 thru 2-60	2-55 thru 2-60	3-81 and 3-82	3-81 and 3-82
2-63 and 2-64	2-63 and 2-64	3-87 and 3-88	3-87 and 3-88
2-71 and 2-72	2-71 and 2-72	3-147 thru 3-156	3-147 thru 3-156
2-74.1/ (2-74.2 Blank)	2-74.1/ (2-74.2 Blank)	3-159/(3-160 Blank)	3-159 and 3-160
2-83 and 2-84	2-83 and 2-84	none	3-161 thru 3-172
2-91 and 2-92	2-91 and 2-92	C-1 thru C-3/(C-4 Blank)	C-1 thru C-4
2-121 and 2-122	2-121 and 2-122	D-1 and D-2	D-1 and D-2
2-225 and 2-226	2-225 and 2-226	F-1 thru F-10	F-1 thru F-10
2-243 thru 2-246	2-243 thru 2-246	INDEX-1 thru	INDEX-1 thru
none	2-246.1 thru 2-246.4	INDEX-6	INDEX-6
2-319 thru	2-319 thru	None	INDEX-6.1/(INDEX-6.2 Blank)
2-320.2 Blank	2-320.2 Blank	INDEX-7 thru	INDEX-7 thru
2-361 thru 2-362.8	2-361 thru 2-362.8	INDEX-12	INDEX-12
2-363 thru 2-368	2-363 thru 2-368	None	INDEX-16.1/(INDEX-16.2 Blank)
none	2-368.1 and 2-368.2	INDEX-17 and	INDEX-17 and
2-369 thru 2-374	2-369 thru 2-374	INDEX-18	INDEX-18
2-409 and 2-410	2-409 and 2-410	None	INDEX-20.1/(INDEX-20.2 Blank)
3-3 thru 3-6	3-3 thru 3-6	INDEX-21 and	INDEX-21 and
3-9 thru 3-14	3-9 thru 3-14	INDEX-22	INDEX-22
3-23 and 3-24	3-23 and 3-24	INDEX-25 and	INDEX-25 and
3-31 and 3-32	3-31 and 3-32	INDEX-26	INDEX-26
none	3-32.1/(3-32.2 Blank)	Metric Conversion	Metric Conversion
none	3-38.1/(3-38.2 Blank)	Chart	Chart

Place this change sheet in the front of the publication for reference purposes.

By Order of the Secretary of the Army:

Official:


SANDRA R. RILEY
*Administrative Assistant to the
Secretary of the Army*
0401502

PETER J. SCHOOMAKER
*General, United States Army
Chief of Staff*

By Order of the Secretary of the Air Force:

Official:

GREGORY S. MARTIN
*General, United States Air Force
Commander, Air Force Materiel Command*

JOHN P. JUMPER
*General, United States Air Force
Chief of Staff*

Distribution:

To be distributed in accordance with the initial distribution number (IDN) 380932,
requirements for TM 9-2320-365-10

**CHANGE
NO. 1**

**HEADQUARTERS
DEPARTMENTS OF THE ARMY
AND THE AIR FORCE**

Washington, D.C., 31 May 2001

**OPERATOR'S INSTRUCTIONS MANUAL
M1078 SERIES, 2-1/2-TON, 4x4,
LIGHT MEDIUM TACTICAL VEHICLE (LMTV)**

TM 9-2320-365-10, 17 June 1998, is changed as follows:

1. Remove old pages and insert new pages as indicated below.
2. New or changed material is indicated by a vertical bar in the outer margin of the page.
3. Added or revised illustrations are indicated by a vertical bar adjacent to the illustration.

Remove Pages	Insert Pages	Remove Pages	Insert Pages
a thru p	a thru p	2-133 thru 2-140	2-133 thru 2-140
none	q and r	2-143 thru 2-148	2-143 thru 2-148
none	A and B	2-153 and 2-154	2-153 and 2-154
i thru iv	i thru iv	2-157 thru 2-170	2-157 thru 2-170
1-1 and 1-2	1-1 and 1-2	2-173 thru 2-176	2-173 thru 2-176
1-9 thru 1-12	1-9 thru 1-12	2-179 and 2-180	2-179 and 2-180
1-15 and 1-16	1-15 and 1-16	2-191 thru 2-194	2-191 thru 2-194
1-21 thru 1-40	1-21 thru 1-40	2-199 and 2-200	2-199 and 2-200
1-47 and 1-48	1-47 and 1-48	2-207 and 2-208	2-207 and 2-208
2-1 thru 2-14	2-1 thru 2-14	2-211 thru 2-214	2-211 thru 2-214
2-19 thru 2-22	2-19 thru 2-22	none	2-214.1 thru 2-214.3/ (2-214.4 Blank)
2-25 and 2-26	2-25/(2-26 Blank)	2-215 thru 2-234	2-215 thru 2-234
2-35 and 2-36	2-35 and 2-36	none	2-234.1 thru 2-234.19/ (2-234.20 Blank)
2-39 and 2-40	2-39 and 2-40	2-235 and 2-236	2-235 and 2-236
none	2-40.1/(2-40.2 Blank)	2-279 thru 2-282	2-279 thru 2-282
2-41 and 2-42	2-41 and 2-42	none	2-286.1/(2-286.2 Blank)
none	2-42.1/(2-42.2 Blank)	2-291 and 2-292	2-291 and 2-292
2-43 thru 2-50	2-43 thru 2-50	2-295 and 2-296	2-295 and 2-296
2-55 thru 2-60	2-55 thru 2-60	2-307 thru 2-310	2-307 thru 2-310
none	2-60.1/(2-60.2 Blank)	none	2-310.1/(2-310.2 Blank)
2-61 thru 2-74	2-61 thru 2-74	2-317 and 2-318	2-317 and 2-318
none	2-74.1/(2-74.2 Blank)	none	2-318.1/(2-318.2 Blank)
2-79 and 2-80	2-79 and 2-80	2-319 and 2-320	2-319 and 2-320
2-83 thru 2-92	2-83 thru 2-92	none	2-320.1/(2-320.2 Blank)
2-95 thru 2-100	2-95 thru 2-100	2-321 and 2-322	2-321 and 2-322
2-105 thru 2-110	2-105 thru 2-110	2-323 thru 2-328	none
2-113 and 2-114	2-113 and 2-114	2-329 and 2-330	2-329 and 2-330
2-121 and 2-122	2-121 and 2-122	2-347 and 2-348	2-347/(2-348 Blank)
2-129 thru 2-132	2-129 thru 2-132		
none	2-132.1/(2-132.2 Blank)		

Place this change sheet in the front of the publication for reference purposes.


Remove Pages	Insert Pages	Remove Pages	Insert Pages
2-349 thru 2-354	none	DA Form 2028-2	none
2-355 thru 2-360	2-355 thru 2-360	DA Form 2028-2	none
none	2-362.1 thru 2-362.9/ (2-362.10 Blank)	Metric Conversion Chart	Metric Conversion Chart
2-363 and 2-364	2-363 and 2-364		
2-375 thru 2-380	2-375 thru 2-379/ (2-380 Blank)		
2-381 thru 2-404	none		
2-405 thru 2-410	2-405 thru 2-410		
none	2-410.1/(2-410.2 Blank)		
2-413 thru 2-415/ (2-416 Blank)	2-413 thru 2-415/ (2-416 Blank)		
3-1 thru 3-70	3-1 thru 3-70		
none	3-70.1 thru 3-70.12		
3-71 thru 3-76	3-71 thru 3-76		
3-79 thru 3-86	3-79 thru 3-86		
3-91 and 3-92	3-91 and 3-92		
3-101 thru 3-110	3-101 thru 3-110		
none	3-110.1 thru 3-110.6		
3-111 thru 3-114	3-111 thru 3-114		
none	3-114.1/(3-114.2 Blank)		
3-115 thru 3-126	3-115 thru 3-126		
none	3-126.1 and 3-126.2		
3-127 thru 3-130	3-127 thru 3-130		
none	3-130.1 and 3-130.2		
3-131 thru 3-138	3-131 thru 3-138		
none	3-138.1 thru 3-138.3/ (3-138.4 Blank)		
3-139 thru 3-146	3-139 thru 3-146		
none	3-157 thru 3-159/ (3-160 Blank)		
A-3 and A-4	A-3 and A-4		
B-3 thru B-12	B-3 thru B-12		
B-13/(B-14 Blank)	none		
C-1 thru C-3/ (C-4 Blank)	C-1 thru C-3/ (C-4 Blank)		
D-1 thru D-4	D-1 thru D-4		
E-5 thru E-7/ (E-8 Blank)	E-5 thru E-7/ (E-8 Blank)		
F-1 thru F-8	F-1 thru F-8		
None	F-8.1/(F-8.2 Blank)		
F-9 thru F-11/ (F-12 Blank)	F-9 thru F-11/ (F-12 Blank)		
INDEX-1 thru INDEX-30	INDEX-1 thru INDEX-29/ (INDEX-30 Blank)		
DA Form 2028-2 Sample	none		
DA Form 2028-2	none		

Place this change sheet in the front of the publication for reference purposes.

By Order of the Secretary of the Army:

ERIC K. SHINSEKI
General, United States Army
Chief of Staff

Official:


JOEL B. HUDSON

Administrative Assistant to the
Secretary of the Army
0034205

DISTRIBUTION: To be distributed in accordance with the Initial Distribution Number (IDN) 380932, requirements for TM 9-2320-365-10.

LIST OF EFFECTIVE PAGES

Insert latest changed pages. Destroy superseded pages.

NOTE: New or changed material is indicated by a vertical bar in the outer margin of the page.

Dates of issue for original and changed pages are:

Original.....0 17 June 1998
 Change1 31 May 2001
 Change2 20 August 2005

THE TOTAL NUMBER OF PAGES IN THIS PUBLICATION IS 822, CONSISTING OF THE FOLLOWING:

Page No.	*Change No.	Page No.	*Change No.	Page No.	*Change No.
Cover.....	0	2-5.....	0	2-68 thru 2-71	1
Blank.....	0	2-6.....	1	2-72	2
a thru j	1	2-7.....	0	2-73 and 2-74	1
k.....	0	2-8.....	1	2-74.1	2
l thru n	1	2-9.....	2	2-74.2 Blank Added	1
o	0	2-10	0	2-75 thru 2-79	0
p	1	2-11	1	2-80	1
q and r Added	1	2-12	0	2-81 and 2-82	0
A and B.....	2	2-13	1	2-83	2
C Added.....	2	2-14 thru 2-19	0	2-84 thru 2-87	1
D Blank Added.....	2	2-20	1	2-88	0
i.....	2	2-21	0	2-89 and 2-90	1
ii and iii	0	2-22	1	2-91 and 2-92	2
iv.....	1	2-23 and 2-24	0	2-93 and 2-94	0
v thru vii.....	0	2-25	1	2-95	1
viii Blank.....	0	2-26 Blank	1	2-96 and 2-97	0
1-1.....	1	2-27 thru 2-33	0	2-98 and 2-99	1
1-2 thru 1-9.....	0	2-34 thru 2-36	2	2-100 thru 1-104.....	0
1-10 and 1-11	1	2-36.1 Added	2	2-105.....	1
1-12 thru 1-14	0	2-36.2 Blank Added	2	2-106.....	0
1-15 and 1-16	1	2-37 and 2-38	0	2-107 thru 2-109.....	1
1-17 thru 1-20	0	2-39	2	2-110 thru 2-112.....	0
1-21 and 1-22	2	2-40	1	2-113.....	1
1-23	1	2-40.1 Added	1	2-114 thru 2-120.....	0
1-24	2	2-40.2 Blank Added	1	2-121.....	2
1-25	1	2-41 and 2-42	1	2-122.....	1
1-26	2	2-42.1 Added	1	2-123 thru 2-129.....	0
1-27	1	2-42.2 Blank Added	1	2-130.....	1
1-28 thru 1-30	2	2-43 thru 2-50	1	2-131.....	0
1-31 thru 1-33	1	2-51 thru 2-54	0	2-132.....	1
1-34	0	2-55 thru 2-57	2	2-132.1 Added.....	1
1-35	1	2-58	0	2-132.2 Blank Added.....	1
1-36 and 1-37	0	2-59 and 2-60	2	2-133 and 2-134.....	1
1-38	1	2-60.1 Added	1	2-135.....	0
1-39	0	2-60.2 Blank Added	1	2-136 thru 2-140.....	1
1-40	1	2-61	1	2-141 and 2-142.....	0
1-41 thru 1-47	0	2-62	0	2-143 thru 2-145.....	1
1-48	1	2-63	1	2-146.....	0
1-49 and 1-50	0	2-64	2	2-147	1
2-1.....	0	2-65	1	2-148 thru 2-152.....	0
2-2 thru 2-4.....	1	2-66 and 2-67	0	2-153.....	1

* Zero in this column indicates an original page.

LIST OF EFFECTIVE PAGES

Insert latest changed pages. Destroy superseded pages.

Page No.	*Change No.	Page No.	*Change No.	Page No.	*Change No.
2-154 thru 2-157.....	0	2-311 thru 2-317.....	0	2-416 Blank.....	0
2-158 and 2-159.....	1	2-318.....	1	3-1 thru 3-3.....	1
2-160 and 2-161.....	0	2-318.1 Added.....	1	3-4 and 3-5.....	2
2-162 thru 2-164.....	1	2-318.2 Blank Added.....	1	3-6 thru 3-8.....	1
2-165.....	0	2-319.....	1	3-9 thru 3-11.....	2
2-166 and 2-167.....	1	2-320.....	2	3-12.....	1
2-168 and 2-169.....	0	2-320.1.....	2	3-13 and 3-14.....	2
2-170.....	1	2-320.2 Blank Added.....	1	3-15 thru 3-23.....	1
2-171 and 2-172.....	0	2-321.....	0	3-24.....	2
2-173.....	1	2-322.....	1	3-25 thru 3-30.....	1
2-174 and 2-175.....	0	2-323 thru 2-328 Deleted.....	1	3-31 and 3-32.....	2
2-176.....	1	2-329.....	1	3-32.1 Added.....	2
2-177 and 2-178.....	0	2-330 thru 2-346.....	0	3-32.2 Blank Added.....	2
2-179.....	1	2-347.....	1	3-33 thru 3-38.....	1
2-180 thru 2-191.....	0	2-348 Blank.....	1	3-38.1 Added.....	2
2-192 and 2-193.....	1	2-349 thru 2-354 Deleted.....	1	3-38.2 Blank Added.....	2
2-194 thru 2-198.....	0	2-355.....	0	3-39.....	2
2-199.....	1	2-356 thru 2-360.....	1	3-40 thru 3-66.....	1
2-200 thru 2-207.....	0	2-361.....	0	3-66.1 Added.....	2
2-208.....	1	2-362.....	2	3-66.2 Blank Added.....	2
2-209 and 2-210.....	0	2-362.1 Added.....	1	3-67.....	2
2-211 thru 2-213.....	1	2-362.2.....	2	3-68.....	1
2-214.....	0	2-362.3 Added.....	1	3-68.1 Added.....	2
2-214.1 thru 2-214.3		2-362.4.....	2	3-68.2 Blank Added.....	2
Added.....	1	2-362.5 Added.....	1	3-69 thru 3-70.1.....	2
2-214.4 Blank Added.....	1	2-362.6.....	2	3-70.2 thru 3-70.10	
2-215 thru 2-224.....	1	2-362.7 Added.....	1	Added.....	1
2-225 and 2-226.....	2	2-362.8.....	2	3-70.11 and 3-70.12.....	2
2-227 thru 2-234.....	1	2-362.9 Added.....	1	3-70.13 thru 3-70.20	
2-234.1 thru 2-234.19		2-362.10 Blank Added.....	1	Added.....	2
Added.....	1	2-363 and 2-364.....	2	3-71.....	1
2-234.20 Blank Added.....	1	2-365.....	0	3-72.....	2
2-235.....	1	2-366 thru 2-368.....	2	3-73.....	0
2-236 thru 2-243.....	0	2-368.1 and 2-368.2		3-74 thru 3-76.....	1
2-244.....	2	Added.....	2	3-77.....	2
2-245.....	0	2-369 and 2-370.....	2	3-78 and 3-79.....	0
2-246.....	2	2-371.....	0	3-80 and 3-81.....	1
2-246.1 thru 2-246.4		2-372 thru 2-374.....	2	3-82.....	2
Added.....	2	2-375.....	0	3-83 and 3-84.....	1
2-247 thru 2-279.....	0	2-376 thru 2-379.....	1	3-85.....	0
2-280 thru 2-282.....	1	2-380 Blank.....	1	3-86.....	1
2-283 thru 2-286.....	0	2-381 thru 2-404 Deleted.....	1	3-87.....	2
2-286.1 Added.....	1	2-405.....	1	3-88 thru 3-91.....	0
2-286.2 Blank Added.....	1	2-406.....	0	3-92.....	1
2-287 thru 2-291.....	0	2-407.....	1	3-93 thru 3-101.....	0
2-292.....	1	2-408.....	0	3-102.....	1
2-293 and 2-294.....	0	2-409.....	2	3-103.....	0
2-295.....	1	2-410.....	1	3-104 and 3-105.....	1
2-296 thru 2-306.....	0	2-410.1 Added.....	1	3-106.....	0
2-307 thru 2-310.....	1	2-410.2 Blank Added.....	1	3-107 thru 3-110.....	1
2-310.1 Added.....	1	2-411 and 2-412.....	0	3-110.1 thru 3-110.6	
2-310.2 Blank Added.....	1	2-413 thru 2-415.....	1	Added.....	1

* Zero in this column indicates an original page.

LIST OF EFFECTIVE PAGES

Insert latest changed pages. Destroy superseded pages.

Page No.	*Change No.	Page No.	*Change No.
3-111	1	INDEX-6.1 Added	2
3-112 and 3-113	0	INDEX-6.2 Blank Added	2
3-114	1	INDEX-7	2
3-114.1 Added	1	INDEX-8 and	
3-114.2 Blank Added	1	INDEX-9	1
3-115 thru 3-126	1	INDEX-10	2
3-126.1 and 3-126.2		INDEX-11	1
Added	1	INDEX-12	2
3-127 thru 3-130	1	INDEX-13 thru	
3-130.1 and 3-130.2		INDEX-16	1
Added	1	INDEX-16.1 Added	2
3-131 thru 3-138	1	INDEX-16.2 Blank	
3-138.1 thru 3-138.3		Added	2
Added	1	INDEX-17	2
3-138.4 Blank Added	1	INDEX-18 thru	
3-139 thru 3-146	1	INDEX-20	1
3-147 and 3-148	2	INDEX-20.1 Added	2
3-149	0	INDEX-20.2 Blank	
3-150	2	Added	2
3-151	0	INDEX-21	2
3-152 thru 3-155	2	INDEX-22 thru	
3-156	0	INDEX-24	1
3-157 and 3-158 Added	1	INDEX-25 and	
3-159 and 3-160	2	INDEX-26	2
3-161 thru 3-172		INDEX-27 thru	
Added	2	INDEX-29	1
A-1 and A-2	0	INDEX-30 Blank	1
A-3	1		
A-4	0		
B-1 and B-2	0		
B-3 thru B-12	1		
B-13 and B-14 Deleted	1		
C-1	1		
C-2 thru C-4	2		
D-1	2		
D-2 thru D-4	1		
E-1 thru E-4	0		
E-5 and E-6	1		
E-7	0		
E-8 Blank	0		
F-1 thru F-8.1	2		
F-8.2 Blank Added	1		
F-9 and F-10	2		
F-11	1		
F-12 Blank	0		
INDEX-1	2		
INDEX-2	1		
INDEX-3	2		
INDEX-4 and			
INDEX-5	1		
INDEX-6	2		

* Zero in this column indicates an original page.

ARMY TM 9-2320-365-10
AIR FORCE T.O. 36A12-1B-1095-1

TECHNICAL MANUAL
NO. 9-2320-365-10

HEADQUARTERS
DEPARTMENTS OF THE ARMY
AND THE AIR FORCE

TECHNICAL ORDER
NO. 36A12-1B-1095-1

Washington, D.C., 17 June 1998

**Operator's Instructions Manual
M1078 SERIES, 2-1/2 TON, 4x4
LIGHT MEDIUM TACTICAL VEHICLES (LMTV)**

MODEL	NSN	EIC
TRK, CAR., LMTV, M1078		
W/WN	2320-01-360-1898	BHH
W/O WN	2320-01-354-3385	BHD
TRK, VAN., LMTV, M1079		
W/WN	2320-01-360-1891	BHG
W/O WN	2320-01-354-3384	BHE
TRK, CHAS, LMTV, M1080	2320-01-353-9098	BHC
TRK, CAR., LMTV, AIR DROP, M1081		
W/WN	2320-01-360-1899	BHJ
W/O WN	2320-01-355-3064	BHF

REPORTING ERRORS AND RECOMMENDING IMPROVEMENTS

You can help improve this publication. If you find any mistakes or if you know of a way to improve the procedures, please let us know. Submit your DA Form 2028 (Recommended Changes to Equipment Technical Publications), through the Internet, on the Army Electronic Product Support (AEPS) website. The Internet address is <http://aeps.ria.army.mil>. If you need a password, scroll down and click on "ACCESS REQUEST FORM". The DA Form 2028 is located in the ONLINE FORMS PROCESSING section of the AEPS. Fill out the form and click on SUBMIT. Using this form on the AEPS will enable us to respond quicker to your comments and better manage the DA Form 2028 program. You may also mail, fax or Email your letter or DA Form 2028 direct to: AMSTA-LC-CI/TECH PUBS, TACOM-RI, 1 Rock Island Arsenal, Rock Island, IL 61299-7630. The email address is TACOM-TECH-PUBS@ria.army.mil. The fax number is DSN 793-0726 or Commercial (309) 782-0726.

DISTRIBUTION STATEMENT A. Approved for public release; distribution is unlimited.

TABLE OF CONTENTS

	<u>Page</u>
HOW TO USE THIS MANUAL	v
CHAPTER 1. INTRODUCTION	1-1
Section I. General Information	1-1
Section II. Equipment Description	1-10
Section III. Principles of Operation	1-31
CHAPTER 2. OPERATING INSTRUCTIONS	2-1
Section I. Description and Use of Operator's Controls and Indicators	2-3
Section II. Preventive Maintenance Checks and Service	2-30
Section III. Operation Under Usual Conditions	2-126
Section IV. Operation Under Unusual Conditions	2-292
CHAPTER 3. MAINTENANCE INSTRUCTIONS	3-1
Section I. Lubrication Instructions	3-1
Section II. Troubleshooting Instructions	3-2
Section III. Maintenance Procedures	3-72
APPENDIX A. REFERENCES	A-1
APPENDIX B. COMPONENTS OF END ITEM (COEI) AND BASIC ISSUE ITEMS (BII)	B-1
APPENDIX C. ADDITIONAL AUTHORIZATION LIST (AAL)	C-1

	<u>Page</u>
APPENDIX D. EXPENDABLE AND DURABLE ITEMS LIST	D-1
APPENDIX E. STOWAGE AND DECAL/DATA PLATE GUIDE	E-1
APPENDIX F. LUBRICATION INSTRUCTIONS	F-1
ALPHABETICAL (SUBJECT) INDEX	INDEX-1

LIST OF ILLUSTRATIONS

Figure	Title	Page
1-1	M1078 Truck, Cargo: 2 1/2-Ton, 4x4, Dropside	1-3
1-2	M1079 Truck, Van: 2 1/2-Ton, 4x4	1-4
1-3	M1080 Truck, Chassis: 2 1/2-Ton, 4x4	1-5
1-4	M1081 Truck, Cargo: 2 1/2-Ton, 4x4, Dropside, Air Drop	1-6
1-5	Common Vehicle Components Location	1-12
1-6	M1078 and M1081 Cargo Vehicles Components Location	1-18
1-7	M1081 Air Drop Cargo Vehicles Components Location	1-19
1-8	M1079 Van Components Location	1-20
1-9	Powertrain	1-31
1-10	Engine Air Intake System	1-34
1-11	Fuel System	1-35
1-12	Cooling System	1-37
1-13	Electrical System	1-40
1-14	Brake System	1-45
1-15	11K Self-Recovery Winch (SRW)	1-47
1-16	Air System	1-49
2-1	Instrument Panel Controls and Indicators	2-3
2-2	Lighted Indicator Display	2-7
2-3	Main Light Switch	2-10
2-4	WTEC II Transmission ECU Pushbutton Shift Selector (TEPSS)	2-11
2-5	WTEC III Transmission Pushbutton Shift Selector (TPSS)	2-12
2-6	Auxiliary Panel Controls and Indicators	2-13
2-7	Air System Controls	2-14
2-8	Heater/Defrost Controls	2-15
2-9	Central Tire Inflation System (CTIS) Electronic Control Unit (ECU) Controls and Indicators	2-16
2-10	Steering Column Controls	2-17
2-11	Floor-Mounted Controls	2-18
2-12	Door-Mounted Controls	2-19
2-13	Driver's Seat Controls	2-20
2-14	Right Passenger Seat Controls	2-20

LIST OF ILLUSTRATIONS (CONT)

Figure	Title	Page
2-15	Passenger Side Exterior Controls	2-21
2-16	Hydraulic Manifold Controls	2-22
2-17	Driver's Side Exterior Controls and Indicators	2-23
2-18	Troop Transport Alarm Switch	2-24
2-19	Light Material Handling Crane (LMHC) Controls and Indicators	2-25
2-20	Deleted	
2-21	Deleted	
2-22	Van Interior Controls	2-27
2-23	Van Exterior Controls	2-29

LIST OF TABLES

Number	Title	Page
1-1	Differences Between Models	1-21
1-2	Vehicle Dimensions	1-22
1-3	Vehicle Weights and Payloads	1-23
1-4	Vehicle Performance Data	1-23
1-5	Fluid Capacities	1-24
1-6	System Data	1-24
1-7	Vehicle Classification	1-30
2-1	Preventive Maintenance Checks and Services (All Models)	2-34
2-2	Preventive Maintenance Checks and Services (M1078 and M1081)	2-94
2-3	Preventive Maintenance Checks and Services (M1081)	2-111
2-4	Preventive Maintenance Checks and Services (M1079)	2-118
2-5	Central Tire Inflation System (CTIS) Tire Pressures and Restrictions . . .	2-171
2-6	Capacity Chart for Light Material Handling Crane (LMHC)	2-176
2-7	Cargo Bed Side Panel Stowage Information	2-213
2-8	11K Self-Recovery Winch (SRW) Pull Capacity	2-340
2-9	Deleted	
3-1	Malfunction Index	3-2
3-2	Troubleshooting	3-13
3-3	Cold Tire Inflation Pressures and Restrictions	3-87
3-4	General Cleaning Instructions	3-94

HOW TO USE THIS MANUAL

OVERVIEW

This Technical Manual (TM) is provided to help you operate and maintain the Light Medium Tactical Vehicles (LMTV). It is divided into the following major sections in order of appearance:

- **FRONT COVER INDEX.** The front cover index contains a list of the most important topics contained in the manual. It features a black box at the right edge of the cover which corresponds with a black box on the page containing the topic. The topics listed on the front cover are highlighted in the table of contents with a box.
- **WARNING SUMMARY.** Provides a summary of the warnings that appear throughout the manual. Read all WARNINGS and CAUTIONS before performing any operation, troubleshooting or maintenance procedures.
- **TABLE OF CONTENTS.** Lists the Chapters, Sections, Appendixes, and alphabetical Index with Page Number in order of appearance.
- **CHAPTER 1, INTRODUCTION.** Describes the LMTV and provides equipment data.
- **CHAPTER 2, OPERATING INSTRUCTIONS.** Describes operator's controls and indicators, preventive maintenance, and operating instructions.
- **CHAPTER 3, MAINTENANCE INSTRUCTIONS.** Provides instructions for Troubleshooting and operator maintenance.
- **APPENDIX A, REFERENCES.** Lists publications used with the LMTV and reference publications which contain information regarding the equipment.
- **APPENDIX B, COMPONENTS OF END ITEM (COEI) AND BASIC ISSUE ITEMS (BII) LISTS.** Lists and illustrates COEI and BII items issued with the LMTV.
- **APPENDIX C, ADDITIONAL AUTHORIZATION LIST (AAL).** Lists additional items you are authorized for support of the LMTV.
- **APPENDIX D, EXPENDABLE AND DURABLE ITEMS LIST.** Lists expendable and durable Items used in the performance of maintenance procedures.

- **APPENDIX E, STOWAGE AND DECAL/DATA PLATE GUIDE.** Shows the location of signs and details the location of COEI, BII, and AAL items.
- **APPENDIX F, LUBRICATION INSTRUCTIONS.** Gives operator lubrication instructions and the time interval at which lubrication is conducted. Lubrication points are also illustrated.
- **SUBJECT INDEX.** Lists important subjects contained in this Volume in alphabetical order, and gives the paragraph number where they are located.

FINDING INFORMATION

There are several ways to find the information you need in this manual. They are as follows:

- **TABLE OF CONTENTS.** Lists Chapters, Sections, Appendixes, and Indexes with Page Numbers in order of appearance.
- **CHAPTER INDEXES.** List Paragraphs contained in the individual Chapters with Paragraph and Page Numbers in order of appearance.
- **MALFUNCTION INDEX.** Lists malfunctions contained in the Troubleshooting Table with Page Numbers in order of appearance.
- **ALPHABETICAL (SUBJECT) INDEX.** Lists all important topics with Paragraph Numbers in alphabetical order.

TROUBLESHOOTING

Troubleshooting is contained in Chapter 3. When you have a problem with the operation of your equipment, look at Table 3-1, Malfunction Index on Page 3-2. Find the malfunction in the Index. Turn to the Page Number listed for the malfunction in Table 3-2, Troubleshooting. Perform the Steps required to correct the malfunction. If you can not find the malfunction, or the malfunction is not corrected, notify Unit Maintenance.

OPERATION AND MAINTENANCE

- **OPERATION.** Before you operate the LMTV, familiarize yourself with the controls and indicators (Chapter 2, Section I). Perform your BEFORE preventive maintenance (Chapter 2, Section II). Read the operating instructions contained in Chapter 2, Sections III and IV. Always follow the WARNINGS and CAUTIONS. During operation, perform your DURING preventive maintenance, and after operation perform your AFTER preventive maintenance (Chapter 2, Section II).
- **MAINTENANCE.** When you perform maintenance, look over the entire procedure before starting. Make sure you have the necessary tools and materials at hand. Always observe WARNINGS and CAUTIONS.

CHAPTER 1 INTRODUCTION

Section I. GENERAL INFORMATION	1-1
1-1. SCOPE	1-1
1-2. MAINTENANCE FORMS AND PROCEDURES	1-7
1-3. CORROSION PREVENTION AND CONTROL (CPC)	1-7
1-4. DESTRUCTION OF ARMY MATERIEL TO PREVENT ENEMY USE	1-7
1-5. REPORTING EQUIPMENT IMPROVEMENT RECOMMENDATIONS (EIR)	1-8
1-6. WARRANTY INFORMATION	1-8
1-7. NOMENCLATURE CROSS-REFERENCE LIST	1-8
1-8. LIST OF ABBREVIATIONS	1-8
1-9. GLOSSARY	1-10
Section II. EQUIPMENT DESCRIPTION	1-10
1-10. EQUIPMENT CHARACTERISTICS, CAPABILITIES, AND FEATURES	1-10
1-11. LOCATION AND DESCRIPTION OF MAJOR COMPONENTS	1-12
1-12. DIFFERENCES BETWEEN MODELS	1-21
1-13. EQUIPMENT DATA	1-22
Section III. PRINCIPLES OF OPERATION	1-31
1-14. POWERTRAIN	1-31
1-15. ENGINE AIR INTAKE SYSTEM	1-34
1-16. FUEL SYSTEM	1-35
1-17. COOLING SYSTEM	1-37
1-18. ELECTRICAL SYSTEM	1-40
1-19. BRAKE SYSTEM	1-44
1-20. 11K SELF-RECOVERY WINCH (SRW)	1-46
1-21. AIR SYSTEM	1-49

Section I. GENERAL INFORMATION

1-1. SCOPE

This chapter provides general information, equipment description, and principles of operation for the M1078 series Light Medium Tactical Vehicle (LMTV). The LMTV will herein be referred to as the vehicle.

a. Type of Manual. This manual provides instructions for operation and Operator maintenance of the vehicle.

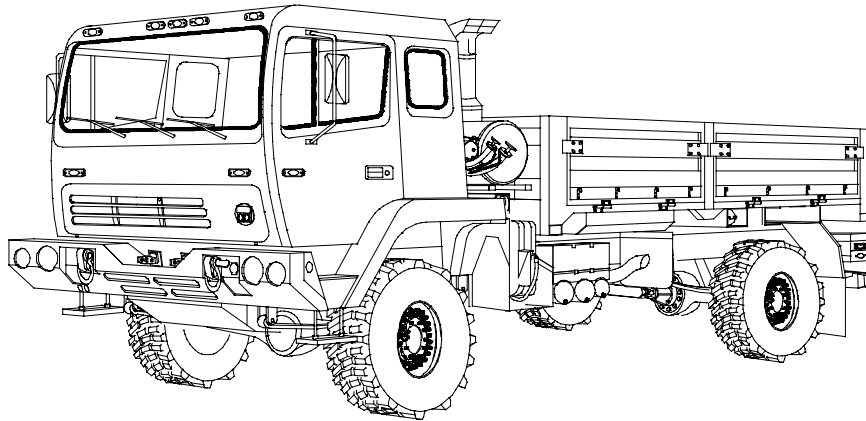
b. Name and Model. The vehicle model numbers and names are listed below:

- M1078 Truck, Cargo: 2 1/2-Ton, 4x4, Dropside (Figure 1-1).
- M1079 Truck, Van: 2 1/2-Ton, 4x4 (Figure 1-2).
- M1080 Truck, Chassis: 2 1/2-Ton, 4x4 (Figure 1-3).
- M1081 Truck, Cargo: 2 1/2-Ton, 4x4, Dropside, Air Drop (Figure 1-4).

1-1. SCOPE (CONT)

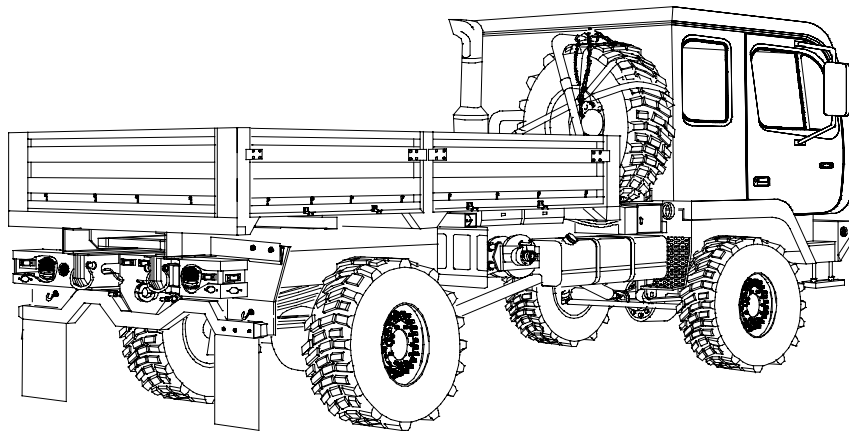
c. Purpose of Equipment. The LMTV series is a family of 4x4 wheeled vehicles. The purpose of these vehicles is as follows:

- (1) M1078 - Cargo hauling vehicle; can be outfitted for troop transport when equipped with a troopseat kit.
- (2) M1079 - Van can be outfitted with communications equipment, or shop equipment installed.
- (3) M1080 - Vehicle chassis; this chassis will accept a cargo bed or may be modified for special missions.
- (4) M1081 - Cargo hauling vehicle; can be airdropped and outfitted for troop transport when equipped with a troopseat kit.



1A01C01A

LEFT FRONT VIEW

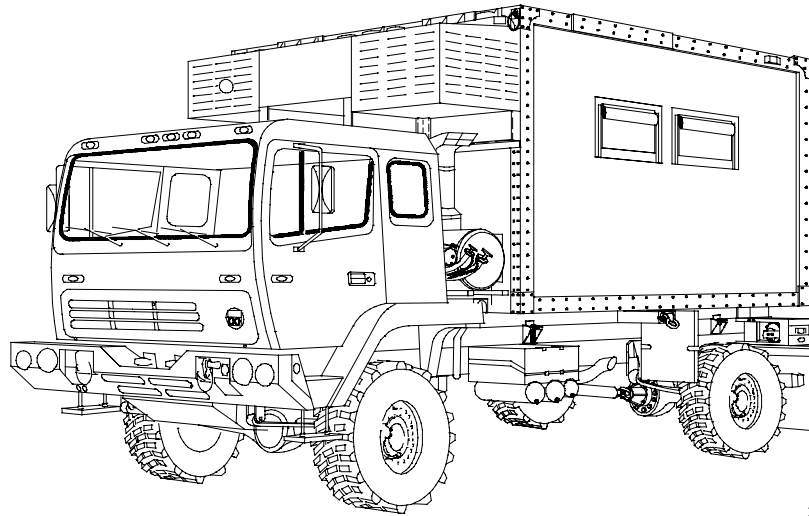


1A01C02A

RIGHT REAR VIEW

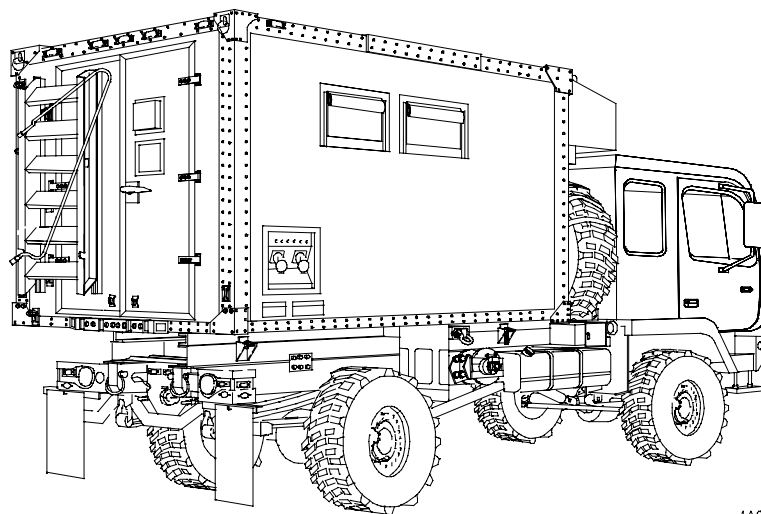
Figure 1-1. M1078 Truck, Cargo: 2 1/2-Ton, 4x4, Dropside

1-1. SCOPE (CONT)



1A01C031

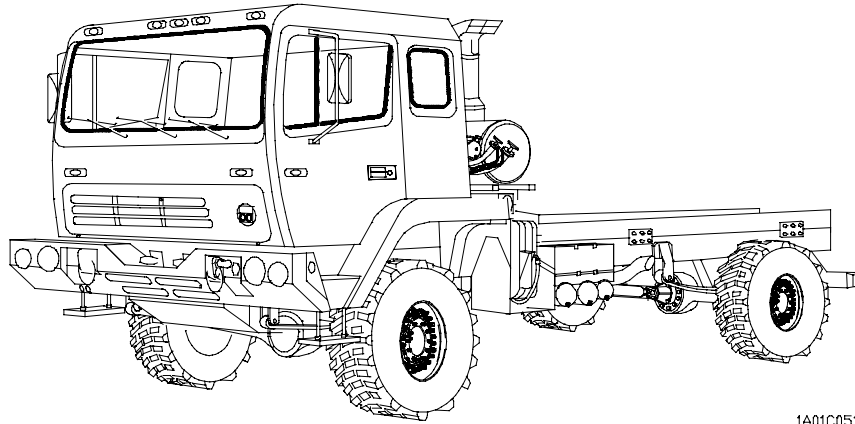
LEFT FRONT VIEW



1A01C041

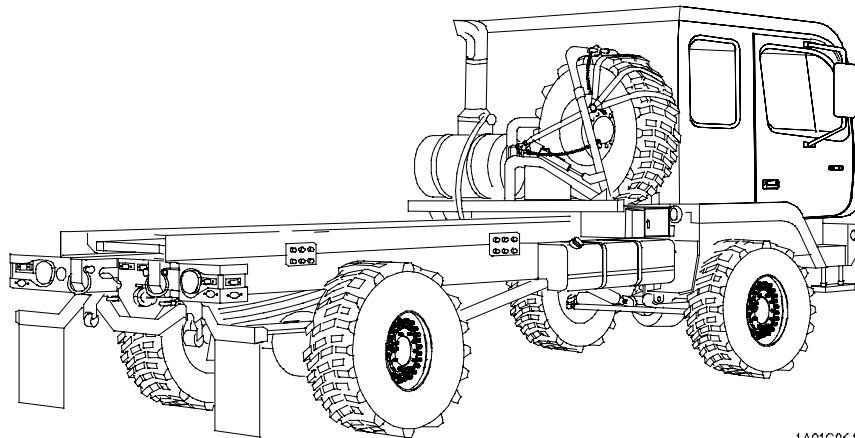
RIGHT REAR VIEW

Figure 1-2 M1079 Truck, Van: 2 1/2 Ton, 4x4.



1A01C051

LEFT FRONT VIEW

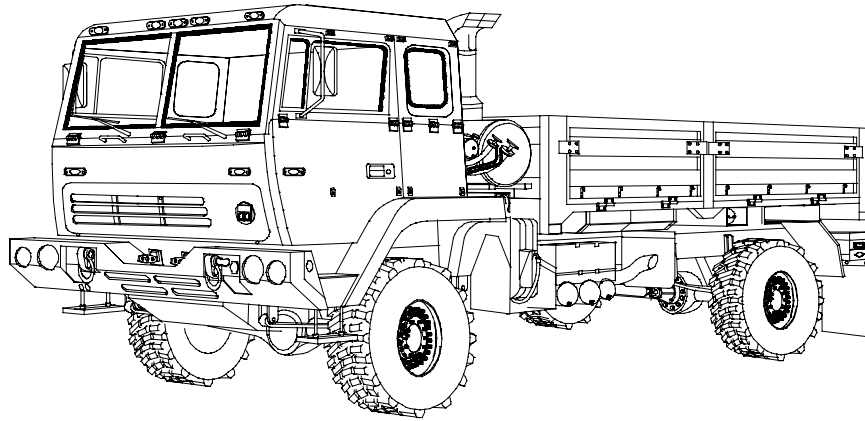


1A01C061

RIGHT REAR VIEW

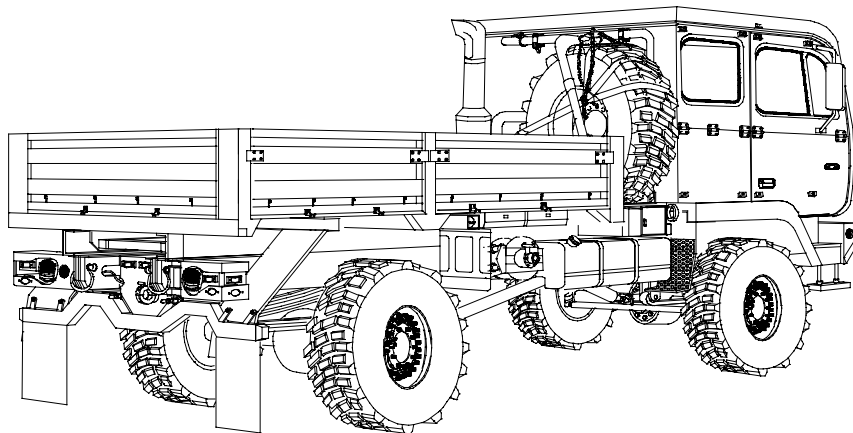
Figure 1-3. M1080 Truck, Chassis: 2 1/2-Ton, 4x4

1-1. SCOPE (CONT)



1A01C071

LEFT FRONT VIEW



1A01C081

RIGHT REAR VIEW

Figure 1-4. M1081 Truck, Cargo: 2 1/2-Ton, 4x4, Dropside, Air Drop

1-2. MAINTENANCE FORMS AND PROCEDURES

Department of the Army forms and procedures used for equipment maintenance will be those prescribed by DA Pam 738-750 as contained in the Maintenance Management Update.

1-3. CORROSION PREVENTION AND CONTROL (CPC)

The vehicle has a total service life of 20 years which allows for extended periods of operation in a corrosive environment. A corrosive environment includes exposure to high humidity, salt spray, road de-icing chemicals, gravel damage, and atmospheric contamination. No action beyond normal washing and repair of damaged areas is needed to control corrosion. To prevent moisture accumulation, drain holes are provided on structural and sheet metal areas where needed, and stowage boxes are provided with seals and baffled drains.

Corrosion Prevention and Control (CPC) of Army materiel is a continuing concern. It is important that any corrosion problems with the vehicle be reported so that the problem can be corrected and improvements made to prevent the problem in the future.

While corrosion is typically associated with rusting of metals, it can also include deterioration of other materials, such as rubber and plastic. Unusual cracking, softening, swelling, or breaking of these materials may be a corrosion problem.

If a corrosion problem is identified, it can be reported using form SF 368 (Product Quality Deficiency Report). Using keywords such as "corrosion", "rust", "cracking", or "deterioration" will ensure that the information is identified as a CPC problem.

Form SF 368 should be submitted to the address specified in DA PAM 738-750.

1-4. DESTRUCTION OF ARMY MATERIEL TO PREVENT ENEMY USE

Command decision, according to the tactical situation, will determine when the using organization is to destroy a vehicle. A destruction plan will be prepared by the using organization, unless one was prepared by a higher authority. For general vehicle destruction procedures, refer to TM 750-244-6, Procedures for Destruction of Tank-Automotive Equipment to Prevent Enemy Use (U.S. Army Tank-automotive and Artillery Command).

1-5. REPORTING EQUIPMENT IMPROVEMENT RECOMMENDATIONS (EIR)

If your vehicle needs improvement, let us know. Send us an EIR. You, the user, are the only one who can tell us what you don't like about your equipment. Let us know why you don't like the design or performance. Put it on an SF 368. Mail it to us at: Commander, U.S. Army Tank-automotive and Armaments Command, ATTN: AMSTA-TR-E/FMTV/312, Warren, MI 48397-5000. We'll send you a reply.

1-6. WARRANTY INFORMATION

The vehicle is warranted by Stewart & Stevenson Services, Inc., Tactical Vehicle Systems Division for 18 months or 12,000 miles (19,308 km), whichever comes first. For complete information covering this warranty, refer to TB 9-2300-365-15, Warranty Program for M1078 Series, 2 1/2 Ton, 4x4, Light Medium Tactical Vehicles (LMTV).

1-7. NOMENCLATURE CROSS-REFERENCE LIST

<u>COMMON NAME</u>	<u>OFFICIAL NOMENCLATURE</u>
Cold Start System	Ether quick-start system
Engine Coolant	Antifreeze, ethylene glycol mixture
Gladhand	Quick-disconnect coupling
Parking Brake	SYSTEM PARK Control
Throttle Pedal	Accelerator pedal

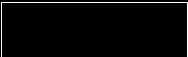
1-8. LIST OF ABBREVIATIONS

<u>ABBREVIATION</u>	<u>NAME</u>
AAL	Additional Authorization List
amp	Amperes
AOAP	Army Oil Analysis Program
ATAAC	Air to Air Aftercooler
BII	Basic Issue Item
°C	Degrees Celsius
CAC	Charge Air Cooler
CBR	Chemical, Biological, and Radiological
CCW	Counterclockwise
cid	Cubic Inch Displacement
cm	Centimeter
COEI	Component of End Item
CPC	Corrosion Prevention and Control
CTIS	Central Tire Inflation System
CW	Clockwise
DA	Department of the Army

<u>ABBREVIATION</u>	<u>NAME</u>
ECU	Electronic Control Unit
EIR	Equipment Improvement Recommendation
°F	Degrees Fahrenheit
FMVSS	Federal Motor Vehicle Safety Standard
ft	Foot
gal	Gallon, U.S.
GCWR	Gross Combination Weight Rating
GPFU	Gas Particulate Filter Unit
GVW	Gross Vehicle Weight
HI	High
hp	Horse Power
in.	Inch
kg	Kilogram
km/h	Kilometer Per Hour
kPa	Kilopascal
kw	Kilowatt
L	Liter
LED	Light Emitting Diode
lb	Pound
LH	Left Hand
LMTV	Light Medium Tactical Vehicle
m	Meter
MGVW	Maximum Gross Vehicle Weight
mi	Mile
mm	Millimeter
mph	Miles Per Hour
MTOE	Modified Table of Organization and Equipment
NBC	Nuclear, Biological, Chemical
PMCS	Preventive Maintenance Checks and Services
psi	Pounds Per Square Inch
PDP	Power Distribution Panel
PTO	Power Take-Off
qt	Quart
RH	Right Hand
rpm	Revolutions Per Minute
SAE	Society of Automotive Engineers
SRW	11K Self-Recovery Winch
TAMMS	The Army Maintenance Management System
TM	Technical Manual
vac	Volts Alternating Current
vdc	Volts Direct Current
WTEC II	World Transmission Electronic Control II
WTEC II TEPSS	WTEC II Transmission ECU Pushbutton Shift Selector
WTEC III	World Transmission Electronic Control III
WTEC III TPSS	WTEC III Transmission Pushbutton Shift Selector
XMSN	Transmission

1-9. GLOSSARY

<u>NOMENCLATURE</u>	<u>DEFINITION</u>
Alternator	Engine-driven generator used to charge batteries.
Fuel Injection	Method that fuel enters engine cylinders; through specially designed nozzles (injectors).
Parallel Connection	More than one battery connected together from positive to positive and from negative to negative.
Power Take-Off (PTO)	Gear-driven device used to power hydraulic equipment (e.g., 11K Self-Recovery Winch [SRW]).
Rigging	Cable, chains and straps used to secure loads.
Series Connection	More than one battery connected together from positive to negative.
Turbocharger	Air compressor driven by exhaust gases. Used to increase engine power.



Section II. EQUIPMENT DESCRIPTION

1-10. EQUIPMENT CHARACTERISTICS, CAPABILITIES, AND FEATURES

a. Characteristics. The LMTVs are a series of 4x4 tactical vehicles designed for use over all types of roads, cross-country terrain, and in all weather conditions. The cab and chassis for all vehicle models are similar. Each vehicle model is equipped with a unique body and may be equipped with other auxiliary equipment depending on vehicle mission.

b. Capabilities.

- (1) The vehicle operates in temperatures from -25°F to 120°F (-32°C to 49°C).
- (2) The vehicle can ford water up to 30 in. (76 cm) deep for 15 minutes without damage or requiring maintenance before operation can continue.

(3) The normal operating range for the vehicle is 300 mi (483 km), based on 54 gal (204 L) of fuel and vehicle at maximum gross vehicle weight when operated at an average speed of 25 mph (40 km/h). Varying loads, prolonged idle, use of Power Take-Off (PTO), off-road driving, and climatic conditions will affect operating range.

(4) Tiedown points are located so that the vehicle can be restrained in all directions during air transport in C-130 and C-141 aircraft. The vehicles are capable of being transported by highway, rail, and sea.

c. Features.

(1) An in-line, six-cylinder, 403 cid (6.6 L), turbocharged diesel engine, producing 225 hp (216 kW).

(2) An automatic transmission with seven forward speeds and one reverse speed. The transmission incorporates an integral transfer case. Normal mode is used when operating the vehicle under usual conditions. Off-road mode is used when operating on unimproved road surfaces. When operating in the normal mode, 70 percent of the power is distributed to the rear axles and 30 percent to the front axle. When operating in the off-road mode, power is evenly distributed between the front and rear axles.

(3) A power steering system consisting of a recirculating ball type steering gear box with hydraulic boost. Mechanical linkage provides the Operator with control in the event of steering oil pressure loss.

(4) A fuel system which includes; a 56 gal (212 L) capacity, 54 gal (204 L) useable fuel tank, fuel/water separator with fuel priming pump, fuel transfer pump, secondary fuel filter, and fuel injectors.

(5) Two front and two rear towing eyes with shackles.

(6) A manually operated pintle hook for towing a trailer or a disabled vehicle.

(7) A Central Tire Inflation System (CTIS) that allows the Operator to adjust tire pressure, with the touch of a button, to suit terrain conditions.

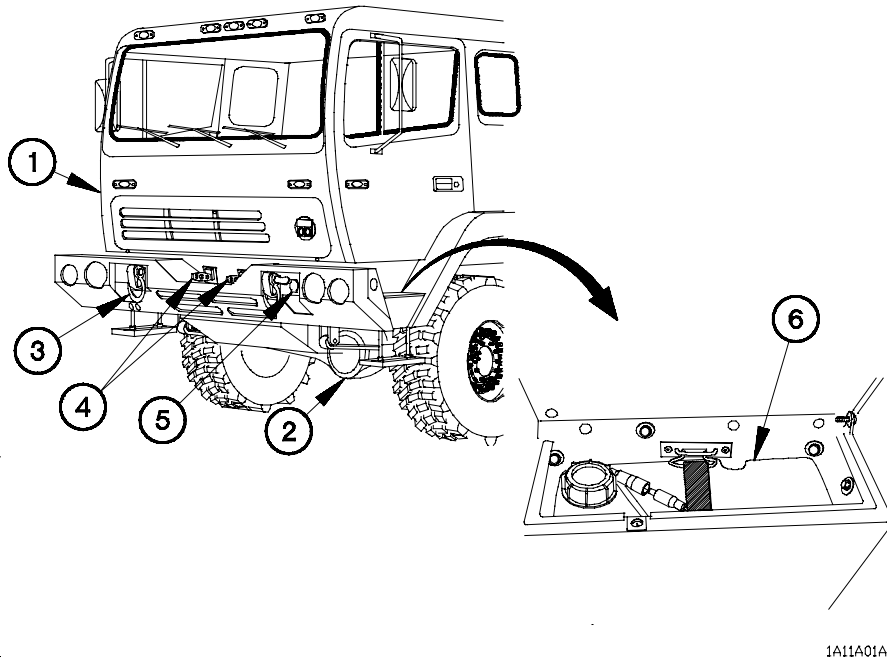
(8) A cab with accommodations for three personnel, or two personnel if a radio is installed.

(9) Service and emergency gladhands at the rear and front of the vehicle for towing a trailer or disabled vehicle, or for being towed.

(10) An air powered hydraulically operated system that allows the Operator to raise and lower the cab and spare tire quickly and easily. This system also provides the Operator with the means to safely and easily lower and raise the vehicle suspension for internal air transport. In addition, a backup hydraulic pump is provided in the event that there is not enough air pressure available to operate the primary system.

1-11. LOCATION AND DESCRIPTION OF MAJOR COMPONENTS

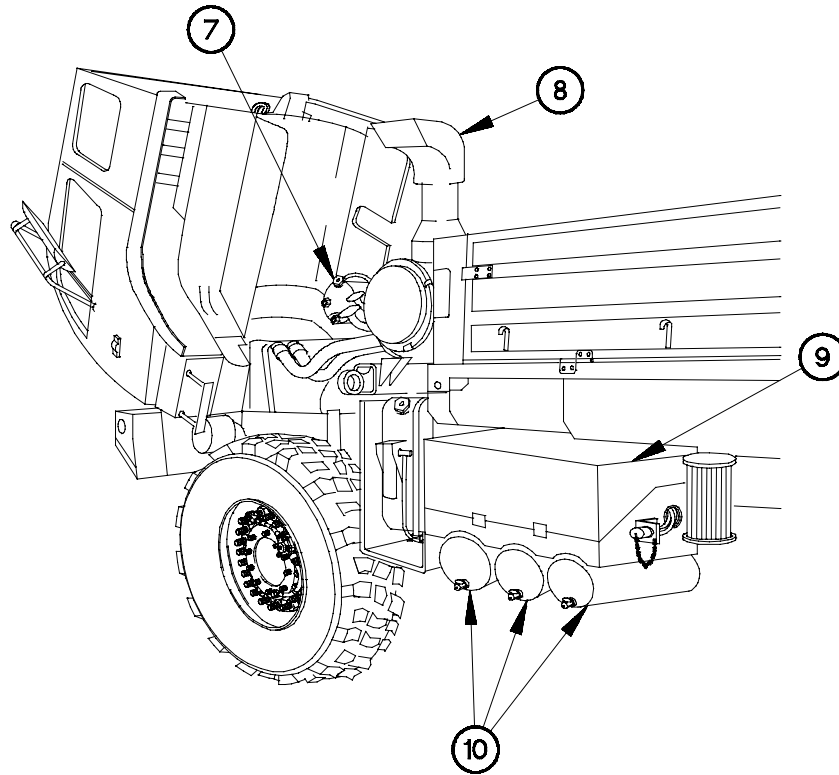
a. Major External Components Common to All Vehicle Variants.



1A11A01A

Figure 1-5. Common Vehicle Components Location

- (1) **CAB.** The cab provides the crew with protection from the weather and contains the controls, gages, and indicators needed to operate the vehicle. The cab accommodates three fully-equipped personnel if no radio is installed, and two fully-equipped personnel if a radio is installed. The cab can be raised and lowered from the hydraulic manifold located on the passenger side of the vehicle.
- (2) **FRONT DRIVING AXLE.** Supports the weight of the vehicle and transmits power to drive the front wheels.
- (3) **FRONT TOW EYES/SHACKLES.** Provides attachment points for towing.
- (4) **FRONT GLADHANDS.** Allows connection of brake air supply between vehicles during towing operations.
- (5) **FRONT ELECTRICAL CONNECTOR.** A connector that receives 12 vdc power from a towing vehicle through an intervehicular cable.
- (6) **WINDSHIELD WASHER RESERVOIR.** A three quart (3 L) reservoir that stores fluid used to clean the windshield.

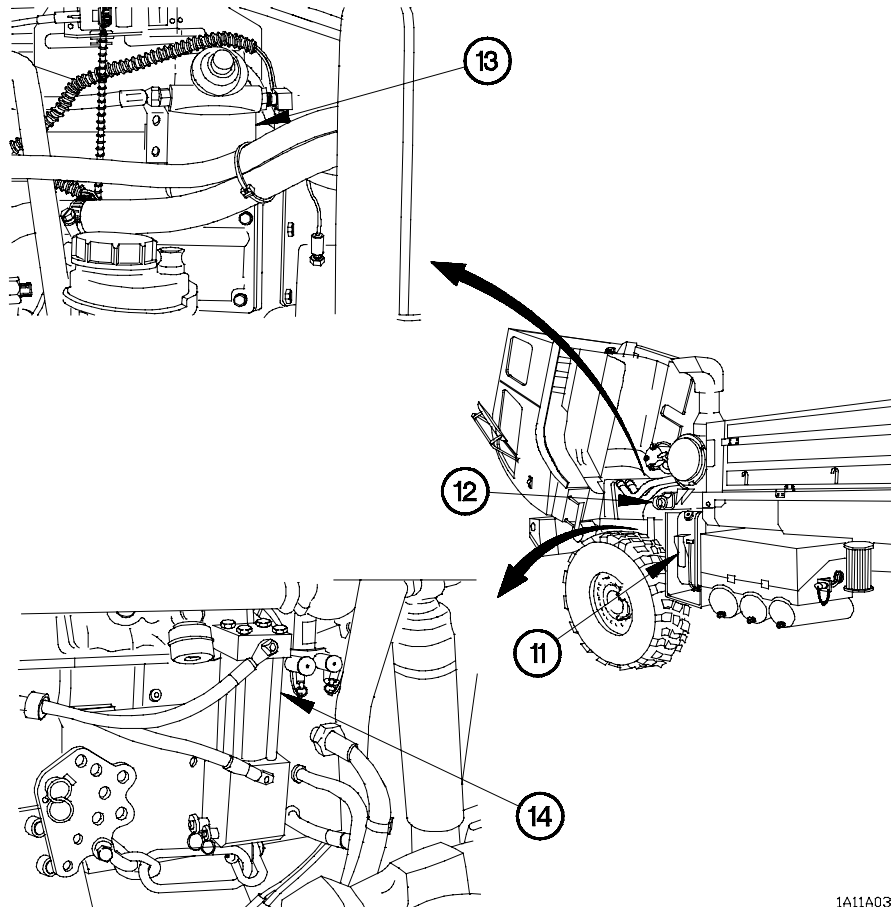


1A11A02A

Figure 1-5. Common Vehicle Components Location (Cont)

- (7) **RADIATOR OVERFLOW TANK.** A reservoir that can store up to eight quarts (7 L) of engine coolant.
- (8) **INTAKE AIR CLEANER ASSEMBLY.** A cartridge-type filter that removes particles from the air before it enters the turbocharger.
- (9) **BATTERY BOX.** The battery box contains four 12 vdc lead-acid batteries connected in series and parallel.
- (10) **AIR TANKS.** The primary and secondary air tanks and the wet tank store compressed air for operation of the brakes, CTIS, and the air/hydraulic power unit.

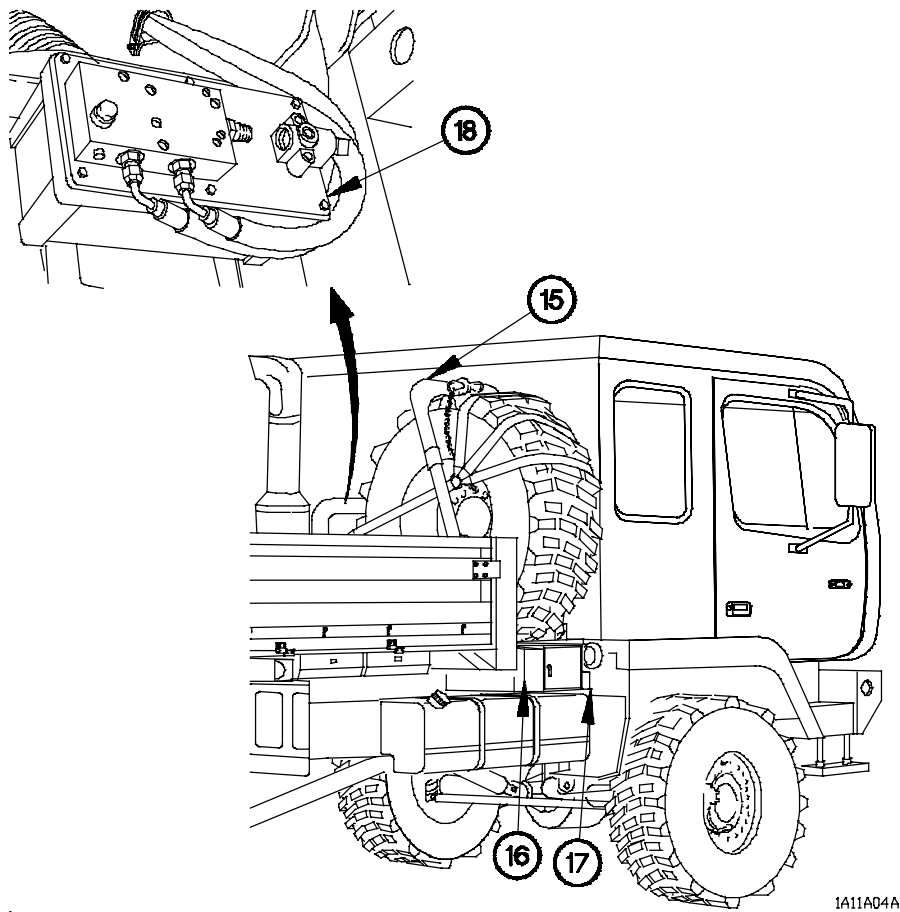
**1-11. LOCATION AND DESCRIPTION OF MAJOR COMPONENTS
(CONT)**



1A11A03A

Figure 1-5. Common Vehicle Components Location (Cont)

- (11) HYDRAULIC RESERVOIR (if equipped).** A 27 gal (102 L) reservoir that stores the oil needed to operate the 11K Self-Recovery Winch (SRW).
- (12) FRONT LIFT BEAM.** Provides attachment points for lifting/loading operations.
- (13) FUEL/WATER SEPARATOR.** Removes moisture and contaminants from the fuel before it enters the fuel pump. The fuel/water separator incorporates a fuel priming pump and an electric heater to prevent gelling of the fuel in cold weather.
- (14) SUSPENSION CYLINDER.** Provides a means of compressing the vehicle suspension in preparation for internal air transport.

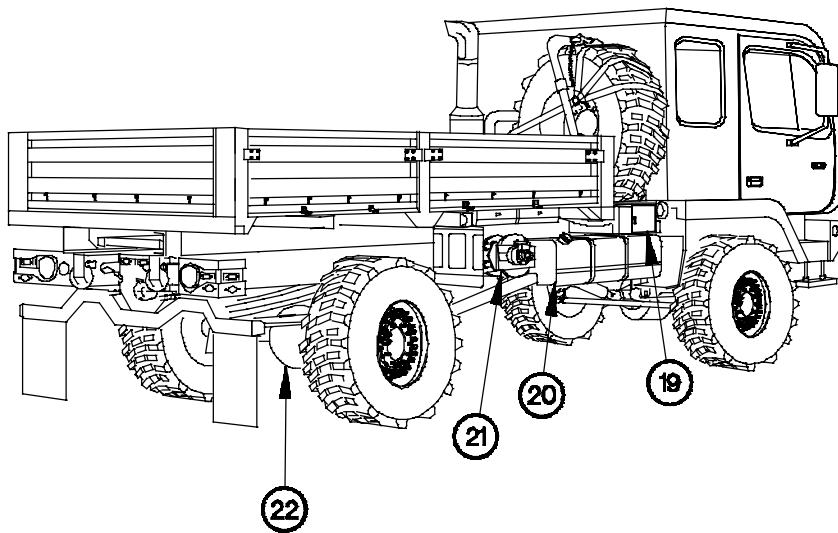


1A11A04A

Figure 1-5. Common Vehicle Components Location (Cont)

- (15) **SPARE TIRE RETAINER.** Provides a stowage location for the spare tire. The operation of the spare tire retainer is controlled from the hydraulic manifold.
- (16) **HYDRAULIC MANIFOLD.** The hydraulic manifold contains the valves and controls used to raise and lower the cab, spare tire, and vehicle suspension.
- (17) **BACK-UP HYDRAULIC PUMP.** This manual pump serves as a backup for the hydraulic manifold. This pump is used in the event that there is not enough air pressure in the air tanks to operate the air/hydraulic power unit. ■
- (18) **AIR/HYDRAULIC POWER UNIT.** Converts air pressure into hydraulic pressure to operate the cylinders used to raise and lower the cab, spare tire, and vehicle suspension.

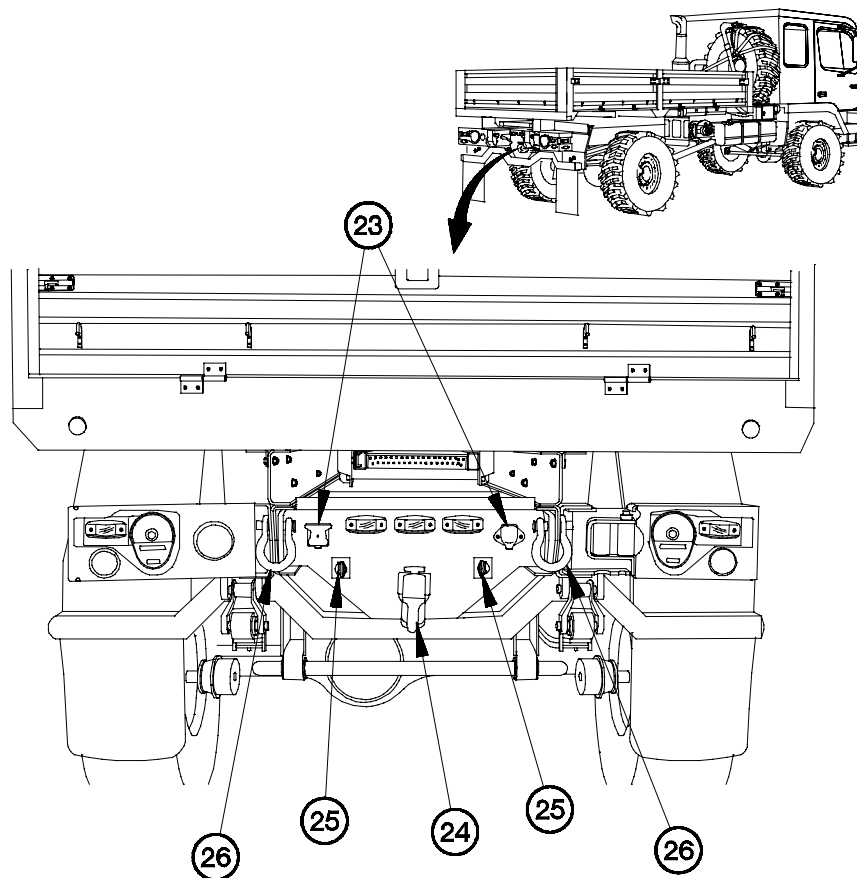
**1-11. LOCATION AND DESCRIPTION OF MAJOR COMPONENTS
(CONT)**



1A11A05A

Figure 1-5. Common Vehicle Components Location (Cont)

- **(19) TOOL BOX.** Used to stow Basic Issue Items (BII), Components of End Item (COEI), and Additional Authorization List (AAL) items.
- **(20) FUEL TANK.** A 56 gal (212 L) capacity, 54 gal (204 L) useable tank stores fuel used to operate the engine.
- (21) 11K SELF-RECOVERY WINCH (SRW) (if equipped).** Provides the Operator with the ability to recover his vehicle from a stranded condition. It also allows the Operator to attempt retrieval of a light vehicle not equipped with a 11K SRW.
- (22) REAR DRIVING AXLE.** Supports the weight of the vehicle and transmits power to drive the rear wheels.



1A11A06A

Figure 1-5. Common Vehicle Components Location (Cont)

- (23) **REAR ELECTRICAL CONNECTORS.** Two connectors (24 vdc/12-pin and 12-vdc/7-pin) that supply electrical power to a trailer or a towed vehicle through an intervehicular cable.
- (24) **PINTLE HOOK.** Hook used for towing a trailer.
- (25) **REAR GLADHANDS.** Allows connection of brake air supply between vehicles or between the towing vehicle and the trailer during towing operations.
- (26) **REAR TOW EYES/SHACKLES.** Provides attachment points for towing.

**1-11. LOCATION AND DESCRIPTION OF MAJOR COMPONENTS
(CONT)**

b. Major External Components Common to M1078 and M1081 Cargo Vehicles.

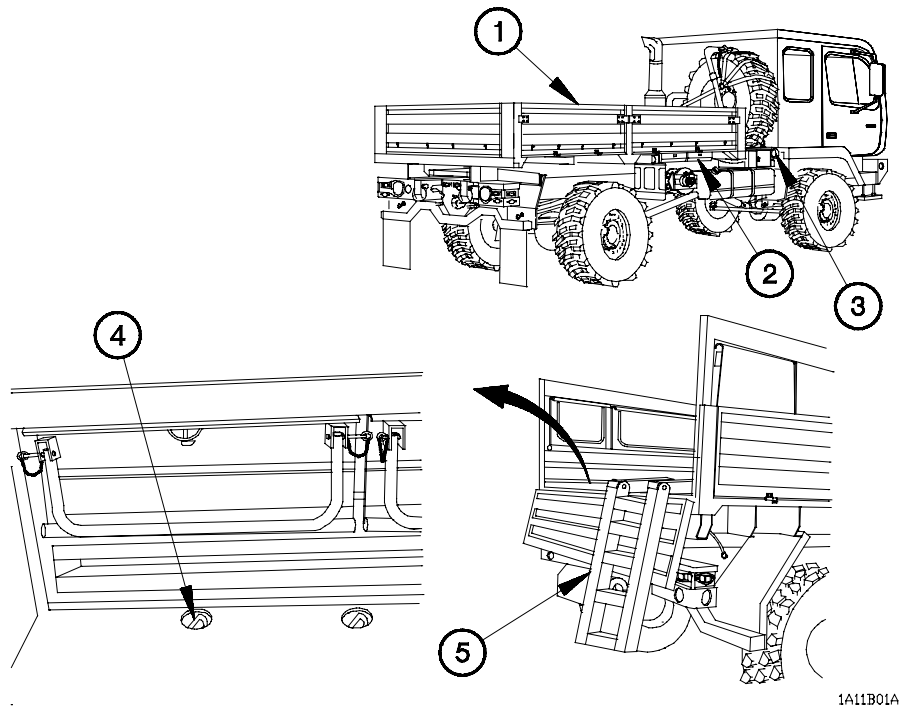
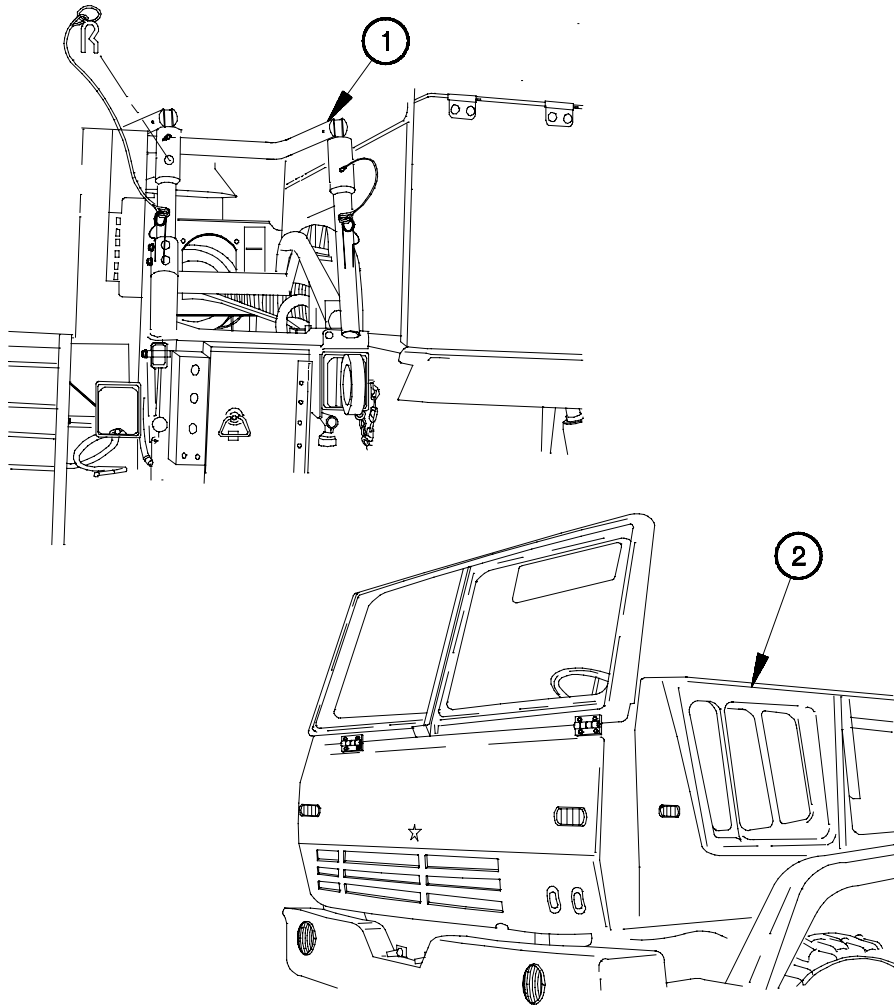


Figure 1-6. M1078 and M1081 Cargo Vehicles Components Location

- (1) **CARGO BED SIDES.** Aluminum panels used to keep cargo from falling out of cargo bed. They may be raised or lowered, or removed and stowed under the cargo bed.
- (2) **CARGO BED SIDE STOWAGE COMPARTMENTS.** Two compartments used to stow cargo bed sides when removed.
- (3) **LIFT BEAM ASSEMBLIES.** Two extendable beams that act as sling spreaders, when deployed, to prevent damage to cargo bed sides during external air transport.
- (4) **CARGO BED TIE DOWNS.** Anchor points for securing cargo.
- (5) **ACCESS LADDER.** Used to assist personnel when climbing into or out of cargo bed. The access ladder is stored underneath the cargo bed when not in use.

c. Major External Components Common to M1081 Air Drop Cargo Vehicles.



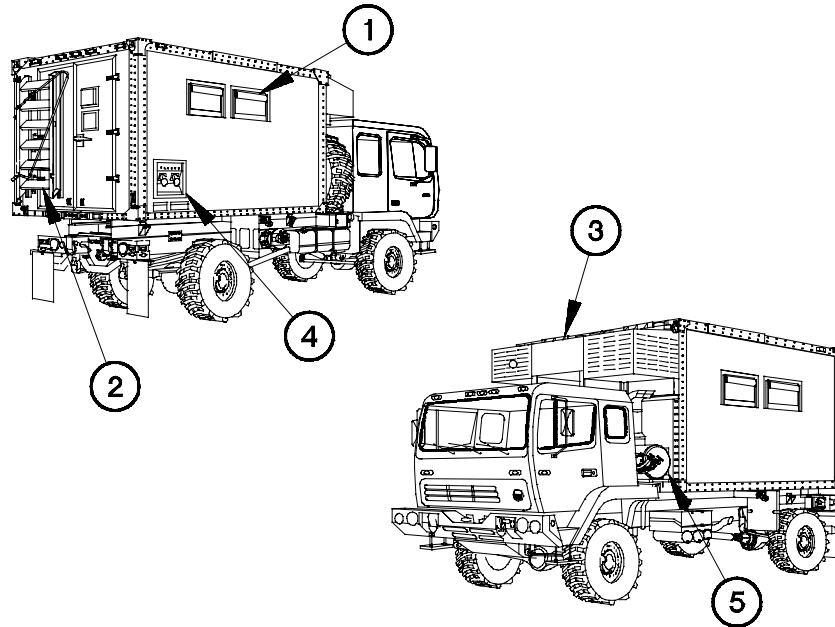
1A11C01A

Figure 1-7. M1081 Air Drop Cargo Vehicles Components Location

- (1) **COLLAPSIBLE SPARE TIRE RETAINER.** The spare tire retainer can be taken apart for air drop operations. Spare tire retainer is provided with a davit used in preparing cab for air drop operations.
- (2) **AIR DROP CAB.** A cab capable of being partially disassembled, to reduce vehicle height, in preparation for internal air transport (C-130 or C-141).

**1-11. LOCATION AND DESCRIPTION OF MAJOR COMPONENTS
(CONT)**

d. Major External Components Common to M1079 Van.



1A11D011

Figure 1-8. M1079 Van Components Location

- (1) **BLACKOUT WINDOWS.** Windows capable of being covered during blackout operations.
- (2) **ACCESS LADDER.** Ladder mounted at the rear of the van body which swings down to provide access to the interior of the van body.
- (3) **POD.** Housing for vent fan, heater, and air conditioner.
- (4) **110/208 VAC POWER PANEL.** Receptacles used to provide van with 110/208 vac.
- (5) **12/24 VDC POWER PANEL.** Provides 12 vdc for van marker lights, and 24 vdc for binding posts and door switch power.

1-12. DIFFERENCES BETWEEN MODELS

Table 1-1. Differences Between Models shows major equipment and operational differences between models of the M1078 series vehicles. An "X" means that model is provided with the equipment/capability listed.

Table 1-1. Differences Between Models

FEATURE	M1078	M1079	M1080	M1081
BODY FEATURE				
Cargo Bed, 12.75 ft (3.2 m)	X			X
Van Body		X		
Air drop capable				X
11K Self-Recovery Winch (SRW)	X	X		X
OPERATING FUNCTION				
Personnel/Cargo Transport	X			
Containment/Storage		X		X
SPECIAL PURPOSE KITS¹				
Bumperette Kit	X	X	X	X
Rim Cover Kit	X	X	X	X
Convex Mirror Kit	X	X	X	X
RH Convex Mirror Kit	X	X	X	X
Resilient Mount Kit	X	X	X	X
Digitization Rack/Storage Kit	X	X	X	
Digitization Electrical Kit	X	X	X	
Deleted				
Cargo Cover, Green Camo	X			X
Cargo Cover Kit, Tan	X			X
Repair Kit, Soft Top	X			X
Light Material Handling Crane (LMHC)	X			X
Machine Gun Ring Mount Kit	X	X	X	X
Rotating Warning Light Kit	X	X	X	X

¹ Vehicles may or may not be equipped with special purpose kits. If an "X" appears under model number, it means that special purpose kit is available for vehicle model.

1-12. DIFFERENCES BETWEEN MODELS (CONT)

Table 1-1. Differences Between Models (Cont)

FEATURE	M1078	M1079	M1080	M1081
SPECIAL PURPOSE KITS (Cont)²				
Troopseat Kit	X			X
Van Body Air Conditioner Kit		X		
Van Body Heater Kit		X		
200 Amp Alternator Kit	X	X	X	X
S-280 Shelter				
Tiedown Kit (Unmodified)	X			X
Modification Kit, Tiedown	X			X
Tiedown Kit (Modified)	X			X
Ladder Adapter, S-290 Shelter	X			X
Cargo Ring Replacement Kit	X		X	X
Vehicle Turning Radius				
35 feet (11 m)	X	X	X	X
WHEELBASE				
155 in. (390 cm)	X	X	X	X

1-13. EQUIPMENT DATA

- a. Table 1-2. Vehicle Dimensions provides overall dimensions for the M1078 series vehicles.

Table 1-2. Vehicle Dimensions

Vehicle	Overall Length	Overall Width	Overall Height
Truck, Cargo, M1078	20 ft 11 in. (6.4 m)	8 ft (2.4 m)	9 ft 4 in. (2.8 m)
Truck, Van, M1079	21 ft 11 in. (6.7 m)	8 ft (2.4 m)	11 ft 10 in. (3.6 m)

² Vehicles may or may not be equipped with special purpose kits. If an "X" appears under model number, it means that special purpose kit is available for vehicle model.

Table 1-2. Vehicle Dimensions (Cont)

Vehicle	Overall Length	Overall Width	Overall Height
Truck, Cargo, Air Drop, M1081	20 ft 11 in. (6.4 m)	8 ft (2.4 m)	9 ft 4 in. (2.8 m)

b. Table 1-3. Vehicle Weights and Payloads provides information regarding the weight and payload of the M1078 series vehicles.

Table 1-3. Vehicle Weights and Payloads

Vehicle	Curb Weight ³	Payload	Maximum Towed Load ⁴	Vehicle Load
Truck, Cargo, M1078	17,770 lbs (8,068 kgs)	5,000 lbs (2,270 kgs)	12,000 lbs (5,448 kgs)	1,200 lbs (549 kgs)
Truck, Van, M1079	18,834 lbs (8,550 kgs)	5,000 lbs (2,270 kgs)	12,000 lbs (5,448 kgs)	1,200 lbs (549 kgs)
Truck, Chassis, M1080	14,861 lbs (6,747 kgs)	5,000 lbs (2,270 kgs)	12,000 lbs (5,448 kgs)	1,200 lbs (549 kgs)
Truck, Cargo, Air Drop, M1081	18,764 lbs (8,519 kgs)	5,000 lbs (2,270 kgs)	12,000 lbs (5,448 kgs)	1,200 lbs (549 kgs)

WARNING

Do not exceed maximum vehicle speed and grade limitations during normal operations. Do not exceed maximum approach or departure angles. Failure to comply may result in serious injury or death to personnel.

³ Curb weight is defined as vehicle weight plus 404 lbs (183 kgs) of fuel weight and 606 lbs (275 kgs) of crew weight.

⁴ Any 2 1/2 ton LMTV vehicle can flat tow any other LMTV vehicle up to GVW. (Gross Vehicle Weight = Curb Weight+Payload).

1-13. EQUIPMENT DATA (CONT)

c. **Table 1-4. Vehicle Performance Data** provides information that is applicable to all M1078 series vehicles.

Table 1-4. Vehicle Performance Data

Maximum Speed	Cruising Range	Maximum Grade	Maximum Approach Angle	Maximum Departure Angles	Maximum Fording Depth
55 mph (88 km/h)	300 mi (480 km)	60 percent	40 degrees	40 degrees	30 in. (76 cm)

d. **Table 1-5. Fluid Capacities** provides information regarding fluid requirements for all M1078 series vehicles.

Table 1-5. Fluid Capacities

Cooling system	43.8 qt (41.5 L)
Deleted	
Engine crankcase.....	25 qt (24 L)
Transmission/transfer case assembly	43.3 qt (41 L)
Fuel tank	56 gal (212 L) capacity, 54 gal (204 L) useable
Steering system reservoir.....	5 qt (4.8 L)
Windshield washer reservoir.....	7.5 qt (7.1 L)
Front differential housing.....	8.5-21.1 qt (8.0-20 L)
Rear differential housing.....	8.5-21.1 qt (8.0-20 L)
Hydraulic reservoir.....	27 gal (102.2 L)
Air transport hydraulic system (total system).....	3 qts (2.8 L)
Air/hydraulic power unit.....	3 pt (1.4 L)
Backup hydraulic pump.....	19 oz (562 ml)

e. **Table 1-6. System Data** provides detail information for the major components of the M1078 series vehicles.

Table 1-6. System Data

ENGINE

Make.....	Caterpillar
Model.....	3116 ATAAC
Type.....	in-line diesel, 4-cycle, turbocharged
Number of Cylinders	6
Bore.....	4.13 in. (105 mm)
Stroke.....	5.0 in. (127 mm)
Displacement.....	403 cid (6.6 L)

Table 1-6. System Data (Cont)

ENGINE (Cont)

Maximum Brake Horsepower (at 2,600 rpm) 225 hp SAE (168 kW)
 Maximum Governed Engine Speed (loaded) 2,600 rpm
 Maximum Governed Engine Speed (no load) 2,860 rpm
 Fuel Governor Auto/Mechanical
 Oil Filter Type Full flow, replaceable element
 Oil Filter Quantity 1

FUEL SYSTEM

Type Mechanical Injection, Cam-Driven
 Number of Fuel Tanks 1
 Fuel Types Diesel, DF-2, JP-4, VV-F-800
 Fuel Filter (primary) Fuel/Water Separator
 Fuel Filter (secondary) Particulate type
 Air Cleaner Type Dry element

COOLING SYSTEM

Type Water, Radiator
 Maximum Radiator Working Pressure 15 psi (103 kPa)
 Fan Engine-driven, clutch-type

AIR COMPRESSOR

Make Midland
 Model EL 1600
 Type Piston-type, Two-cylinder

ELECTRICAL SYSTEM

Alternator
 Make C.E. Niehoff
 Model (100 Amps, 14 vdc/28 vdc) N1506-1
 Type Engine-driven, EMI/RFI suppressed,
 waterproof

Voltage Regulator
 Make C.E. Niehoff
 Model N3030
 Type Solid State

Starting Motor
 Make Prestolite
 Model M0017703MD
 or M0017703ME

Table 1-6. System Data (Cont)

CAB

Personnel Capacity 3
 Seat Design Cushioned with Springs,
 Driver's Forward/Backward Adjustable
 Steering Column Adjustable, Tilt and Telescopic

BRAKE SYSTEM

Front

Make Rockwell
 Model Stopmaster, RSA-1550-830
 Type Full air, wedge-type,
 self-adjusting
 Drum Size 17.2 in. (437 mm) diameter
 by 8.2 in. (208 mm) wide
 Number of Brake Air Chambers 1 per wheel
 Pressure Range 60-120 psi (414-827 kPa)

Rear

Make Rockwell
 Model Stopmaster, RDA-1550-831
 Type Full air, wedge-type,
 self-adjusting
 Drum Size 17.2 in. (437 mm) diameter
 by 8.2 (208 mm) wide
 Number of Brake Air Chambers 2 per wheel
 Pressure Range 60-120 psi (414-827 kPa)

TOWING EYES

Quantity 4 (2 front, 2 rear)

PINTLE HOOK

Type Manual-release
 Maximum Load Capacity
 Pulling 12,000 lb (5,448 kg)
 Vertical 1200 lb (549 kg)

WHEELS

Make Titan
 Rim Size and Type 20 by 10, two-piece, bolt-together
 Quantity 5 (including spare)
 Studs Per Wheel 10
 Maximum Wheel Load 9,000 lbs (4,086 kgs)

TIRES

Make Michelin
 Size 395/85 R20 XML
 Tread Design Non-directional, on-off road
 Ply Rating PR14
 Tube or Tubeless Tubeless

1-13. EQUIPMENT DATA (CONT)

Table 1-6. System Data (Cont)

TIRES (Cont)

Load Range	159G
Maximum Load	9,645 lbs (4,379 kgs)
Maximum Cold Inflation Pressure	95 psi (655 kPa)
Maximum Highway Speed	55 mph (88 km/h)

CENTRAL TIRE INFLATION SYSTEM (CTIS)

Make..... Eaton

TIRE PRESSURES

<u>Terrain Condition</u>	<u>Maximum Speed</u>	<u>Tire Pressure</u>
Highway	55 mph (88 km/h)	55 psi (379 kPa)
Cross Country	40 mph (64 km/h)	33 psi (228 kPa)
Sand (soft terrain)	12 mph (19 km/h)	20 psi (138 kPa)
Emergency	5 mph (8 km/h)	14 psi (97 kPa)
	10 minutes)	

11K SELF-RECOVERY WINCH (SRW) (if equipped)

Make.....	dp Manufacturing
Model.....	11K
Rated Capacity	11,000 lb (4,999 Kgs)
Speeds.....	1
Cable Dimension.....	0.5 in. (12.7 mm) diameter by 280 ft (85 m)

SPECIAL PURPOSE KITS⁵

Bumperette Kit	
Part No.....	57K3398
Rim Cover Kit	
Part No.....	57K1996
Resilient Mount Kit	
Part No.....	57K2003

⁵ Vehicle may be equipped with these items depending on mission, climate, and other factors.

Table 1-6. System Data (Cont)

Cargo Cover Kit (Green Camo) Part No. (M1078/M1081).....	57K1898	■
Cargo Cover Kit (Tan) Part No. (M1078/M1081).....	57K1925	
Repair Kit, Soft Top Part No. (M1078/M1081).....	57K2010	■
Convex Mirror Kit Part No.....	57K1995	■
Light Material Handling Crane (LMHC) Kit Make.....	Grove	
Part No. (M1078/M1081).....	1-195-0-00516	■
Maximum Capacity with Boom Fully Raised.....	1,500 lb (681 kg)	
Machine Gun Ring Mount Kit Part No.....	57K1224	
RH Convex Mirror Kit Part No.....	57K2008	■
Rotating Warning Light Kit Part No.....	57K1220	
Type	12 vdc, Magnet-Mounted	
Troopseat Kit Part No. (M1078/M1081).....	57K1893-001	■
200 Amp Alternator Kit Part No. (M1078, M1080, M1081)	57K1912	
M1079 Van Body Air Conditioner Kit Part No.....	57K1947	
M1079 Van Body Heater Kit Part No.....	57K1948	
Digitization Rack/Storage Kit Part No.....	57K2012	■
Digitization Electrical Kit Part No.....	57K2013	■

1-13. EQUIPMENT DATA (CONT)

SPECIAL PURPOSE KITS⁵ (Cont)

Tiedown, S-280 Shelter	
Part No. (M1078/M1081).....	57K1952 (Unmodified)
Part No. (M1078/M1081).....	57K4449 (Modified)
Modification Kit, S-280 Shelter	
Part No. (M1078/M1081).....	57K4448
Ladder Adapter, S-280 Shelter	
Part No. (M1078/M1081).....	57K1950
Cargo Tiedown Ring Replacement Kit	
Part No. (M1078/M1080/M1081).....	57K2017

WARNING

Bridges along your route may be marked with a class number. The bridge class number shows the safe capacity of the bridge. If the bridge class number on your vehicle is equal to or less than the bridge class number, the bridge will hold your vehicle. If the bridge class number on your vehicle is greater than the bridge class number; **DO NOT CROSS BRIDGE.** Failure to comply may result in serious injury or death to personnel.

NOTE

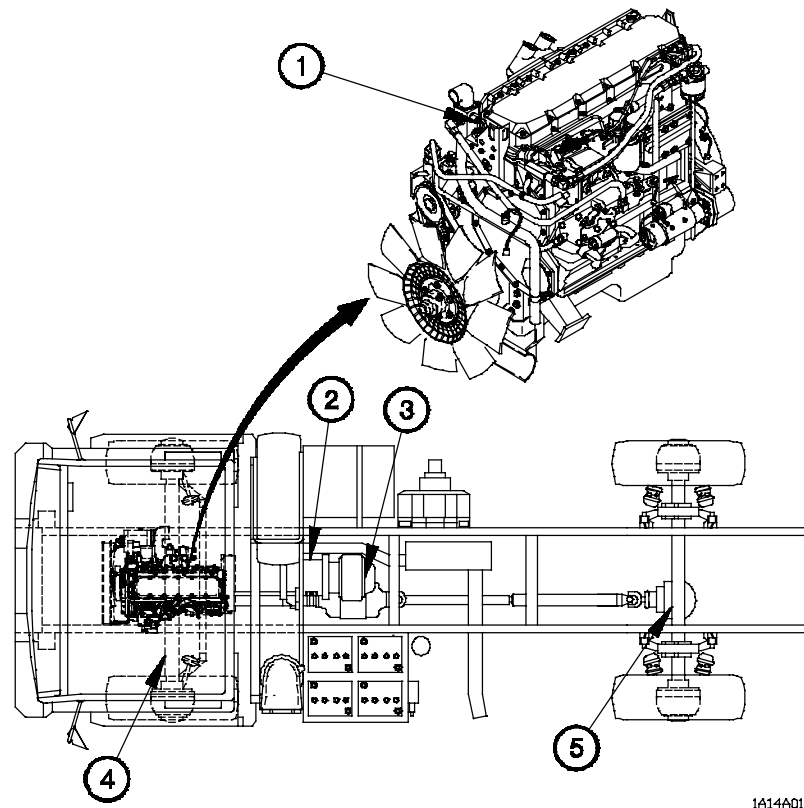
Refer to FM 5-36 Route Reconnaissance and Classification for more information on bridge classification.

Table 1-7. Vehicle Classification

Vehicle	Vehicle Class Number
	Cross-Country/off Highway
M1078	11
M1078 w/SRW	11
M1079	11
M1079 w/SRW	12
M1080	8
M1081	11
M1081 w/SRW	12

Section III. PRINCIPLES OF OPERATION

1-14. POWERTRAIN



1A14A01A

Figure 1-9. Powertrain

The Powertrain for the vehicle is provided by a diesel engine (1, Figure 1-9) which is coupled directly to an automatic transmission (2). Power from the automatic transmission is supplied to the transfer case (3) and on to the front steering axle (4) and rear drive axle (5) through a series of drive shafts and universal joints. The capability of the powertrain is enhanced by the use of an seven-speed transmission.

a. Engine. The vehicle is equipped with a Caterpillar model 3116 ATAAC diesel engine (1, Figure 1-9), rated at 225 hp (168 kW).

1-14. POWERTRAIN (CONT)

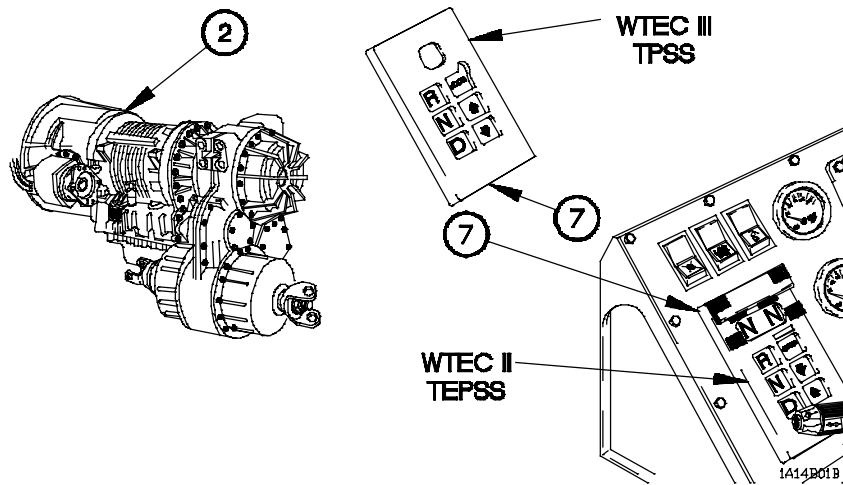


Figure 1-9. Powertrain (Cont)

b. Transmission. The vehicle is equipped with a fully automatic, electronically controlled, seven-speed close-ratio Allison transmission Model MD3070PT (2, Figure 1-9). The WTEC II Transmission ECU Pushbutton Shift Selector (TEPSS) has a velcro cover and the WTEC III Transmission Pushbutton Shift Selector (TPSS) does not have a velcro cover.

(1) The WTEC II TEPSS (7) or WTEC III TPSS (7) is located in the instrument panel, to the Operator's left.

(2) The transmission defaults to Neutral (**N**) whenever electrical power is removed from the vehicle. When electrical power is first supplied to the vehicle, the WTEC II TEPSS or WTEC III TPSS will momentarily display **MODE ON** in the LED display. **MODE ON** display will disappear and **N N** will be left in the LED display. This lets you know that the transmission is in highway mode and Neutral range (**N**).

(3) The Drive (**D**) gear selection is used for normal driving conditions. The transmission will engage 2nd gear when **D** is selected and the vehicle is stopped. The LED display will illuminate **7 2**, indicating that the transmission is in 2nd gear and there are seven forward gears available. Low gear (1st gear), is available only through manual selection by pressing the down arrow button until **1 1** is displayed in the LED display. You may manually downshift or upshift to a lower or higher gear range as required. However, the transmission will not downshift to a lower gear if the engine speed is too high for the gear selected. Selecting a specific gear; for example, 3rd; will prevent the transmission upshifting past the selected gear.

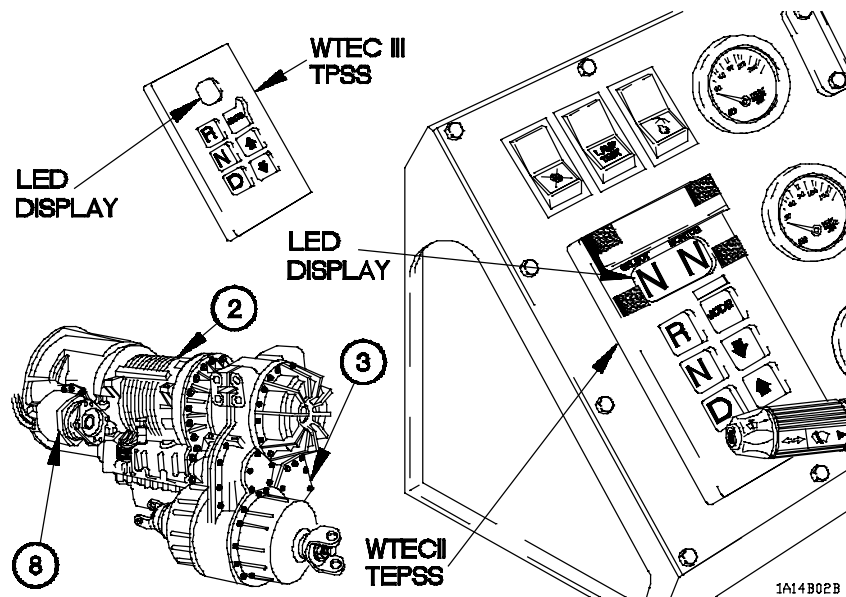


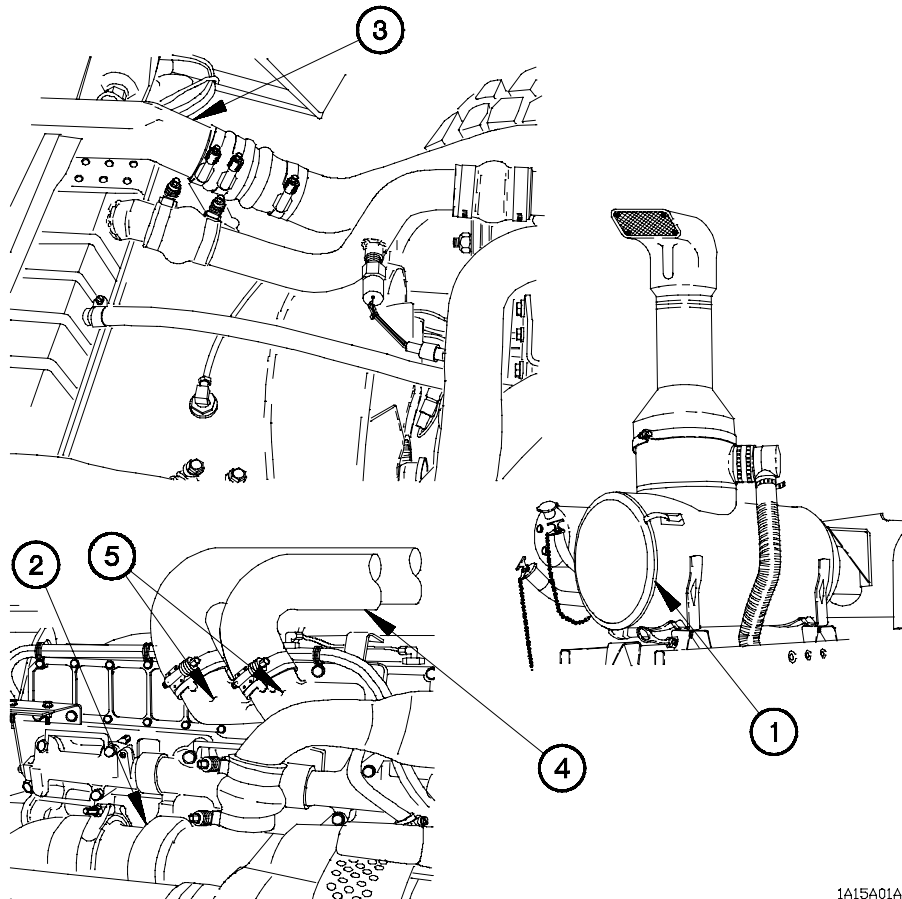
Figure 1-9. Powertrain (Cont)

(4) When the **MODE** button is pressed, **MODE ON** will illuminate in the LED display. If the vehicle is stopped; the LED display will illuminate **5 MODE ON 2**, indicating that the transmission is in 2nd gear and there are five forward gears available. This off-road mode is useful if road or load conditions require the use of a lower gear range for maximum torque. The vehicle must be completely stopped and engine operating at idle speed before the transmission will allow you to shift from a forward gear to Reverse (**R**) gear.

(5) The transmission may include an electrically controlled PTO (8). The PTO provides power to a hydraulic pump, which powers the 11K Self-Recovery Winch (SRW) (if equipped). The transmission will not shift from Neutral (**N**) if the PTO is engaged and the winch switch is in the on position.

c. Transfer Case. The transfer case (3) contains the gears and clutches that provide the transmission (2) with the seventh gear. The transfer case delivers power from the transmission to the front driveshaft and rear driveshaft. In normal driving conditions, the transfer case splits the output torque of the transmission, providing 70 percent of the torque to the rear and 30 percent to the front. In 1st gear, or any time **MODE ON** is illuminated in LED display, the output torque of the transmission is split evenly between front and rear.

1-15. ENGINE AIR INTAKE SYSTEM



1A15A01A

Figure 1-10. Engine Air Intake System

The Engine Air Intake System consists of a dry-type intake air cleaner (1, Figure 1-10), turbocharger (2), and a Charge Air Cooler (CAC) (3). The turbocharger increases engine horsepower by delivering a higher volume of air to the engine. The turbocharger compresses the air and delivers it to the CAC. The air flows through the CAC which cools the air before it is delivered to the engine cylinders. The air aspiration tubes (4) pass the cooled and compressed air to the engine inlet manifold (5). The compressed air/fuel mixture allows more complete burning of the fuel. The result is an increase in horsepower and lower emissions.

1-16. FUEL SYSTEM

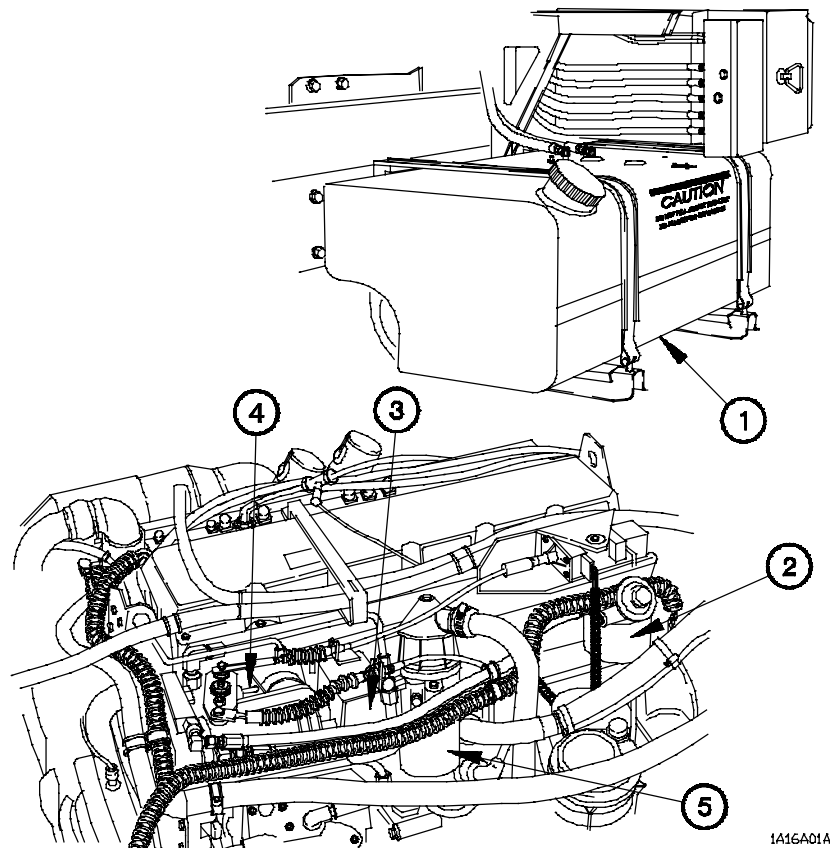


Figure 1-11. Fuel System

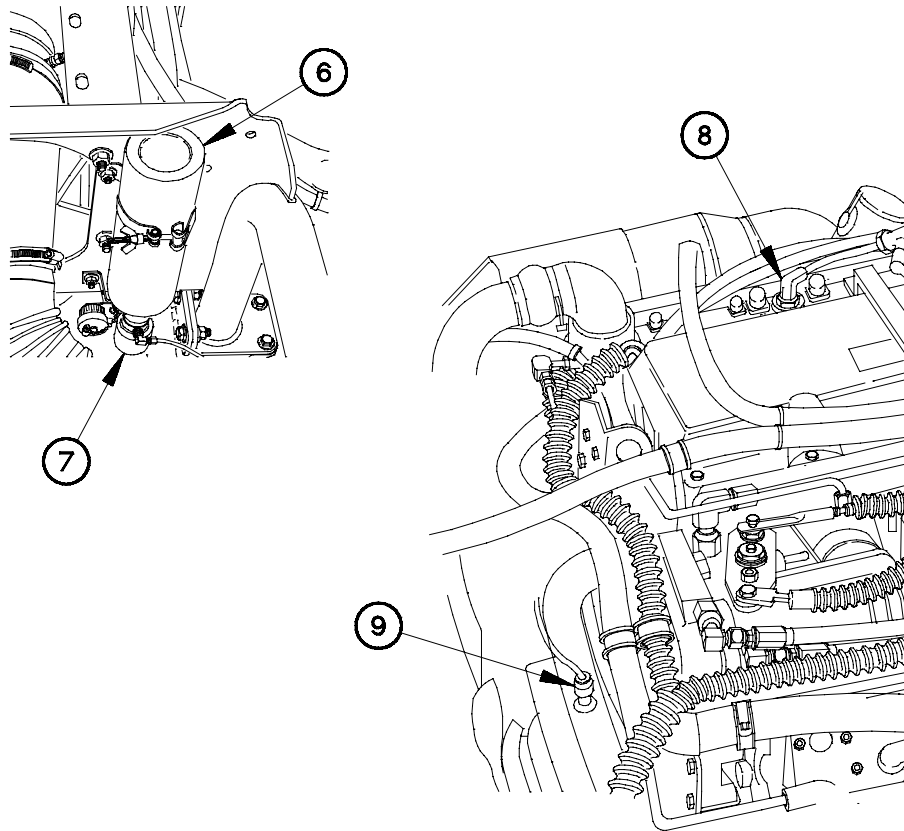
The Fuel System consists of a 56 gal (212 L) capacity, 54 gal (204 L) useable fuel tank (1, Figure 1-11), fuel priming pump and fuel/water separator (2), fuel shutoff solenoid (3), fuel governor (4), and secondary fuel filter (5). ■

(1) The fuel priming pump is hand actuated and is used to pump fuel to the fuel governor after maintenance is performed on certain parts of the fuel system.

(2) The fuel/water separator removes water and large solid particles from the fuel before it is passed to the fuel governor.

(3) The fuel governor responds to input from the accelerator pedal and causes an increase or decrease in engine speed. The fuel governor adjusts the amount of fuel delivered to the engine as engine speed changes.

1-16. FUEL SYSTEM (CONT)



1A16A02A

Figure 1-11. Fuel System (Cont)

(4) The secondary fuel filter removes finer particles from the fuel before it reaches the cylinder head.

(5) The vehicle is also equipped with an ether quick start system for starting the engine when the outside temperature is below 32°F (0°C). The ether quick start system is composed of an ether cylinder (6), ether valve (7), two ether nozzles (8), and an ether sensor switch (9). The ether sensor switch detects the temperature of the engine coolant and disables the ether valve if the coolant temperature is above 100°F (38°C).

1-17. COOLING SYSTEM

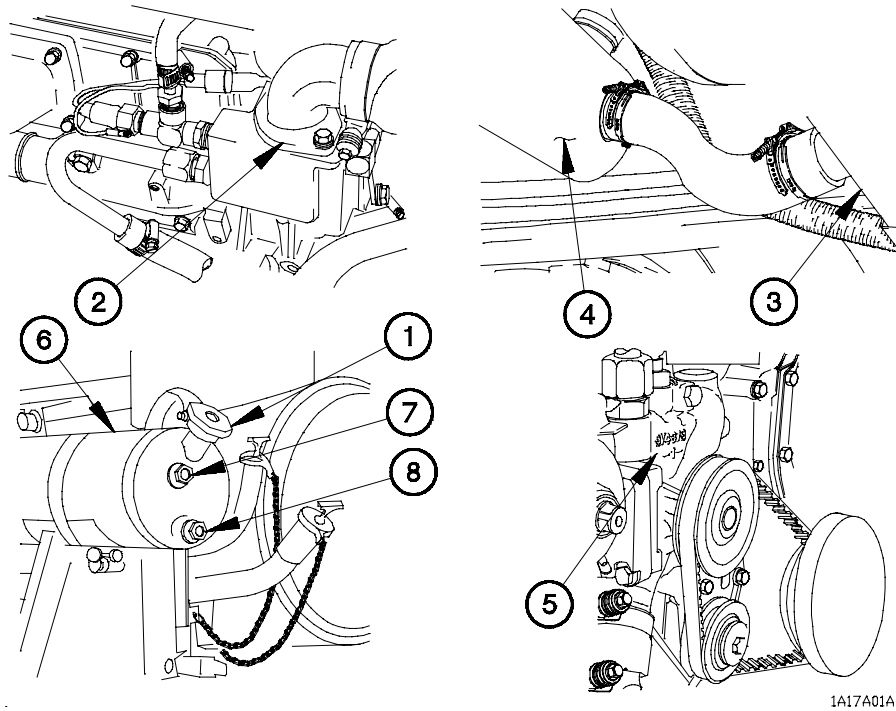


Figure 1-12. Cooling System

The Cooling System protects the engine, transmission, and air compressor by providing a means of removing the heat generated during operation of the vehicle.

(1) The radiator pressure cap (1, Figure 1-12), in combination with the ethylene glycol-based antifreeze, effectively raises the boiling point of the coolant to well above 212°F (100°C).

(2) The thermostat (2) helps the engine to warm up quickly by remaining closed until the coolant temperature reaches approximately 199°F (93°C). When the coolant temperature reaches approximately 199°F (93°C), the thermostat opens and coolant is circulated through the water jacket in the engine to maintain the correct operating temperature for the engine. Coolant is drawn from the radiator (3), through the transmission oil cooler (4), and circulated through the cooling system by the water pump (5). Heat is drawn from the radiator by the engine fan pulling air over the radiator cooling fins.

(3) A radiator overflow tank (6) is provided to allow for expansion of the coolant. The radiator overflow tank also serves as the point where new coolant is introduced into the cooling system. The radiator overflow tank has two sight glasses; the upper sight glass (7) indicates the level to fill to with engine shut down. If coolant is not visible in the lower sight glass (8), do not operate the vehicle.

1-17. COOLING SYSTEM (CONT)

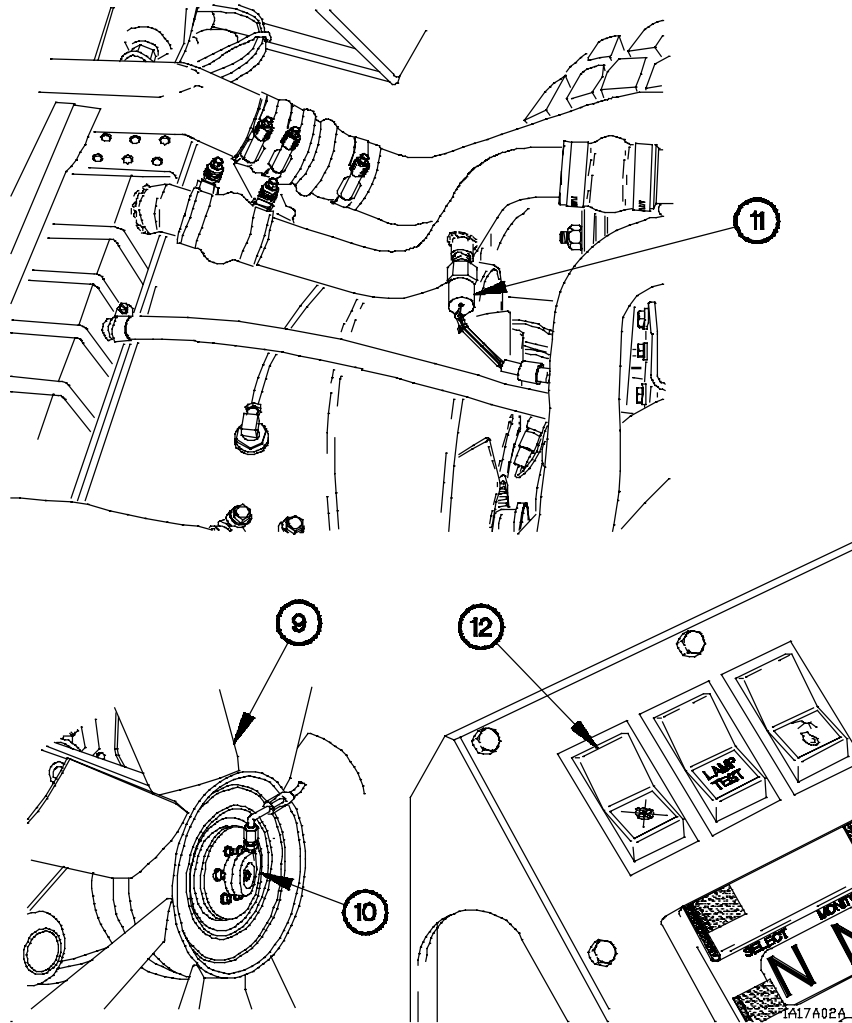


Figure 1-12. Cooling System (Cont)

(4) The engine fan (9), with pneumatic fan clutch (10), is activated by the water temperature sensor (11). Whenever this sensor detects a high engine temperature condition, air pressure is removed from the fan clutch and the engine fan is engaged.

(5) Positioning the radiator fan off switch (12) to the on position keeps the engine fan from engaging.

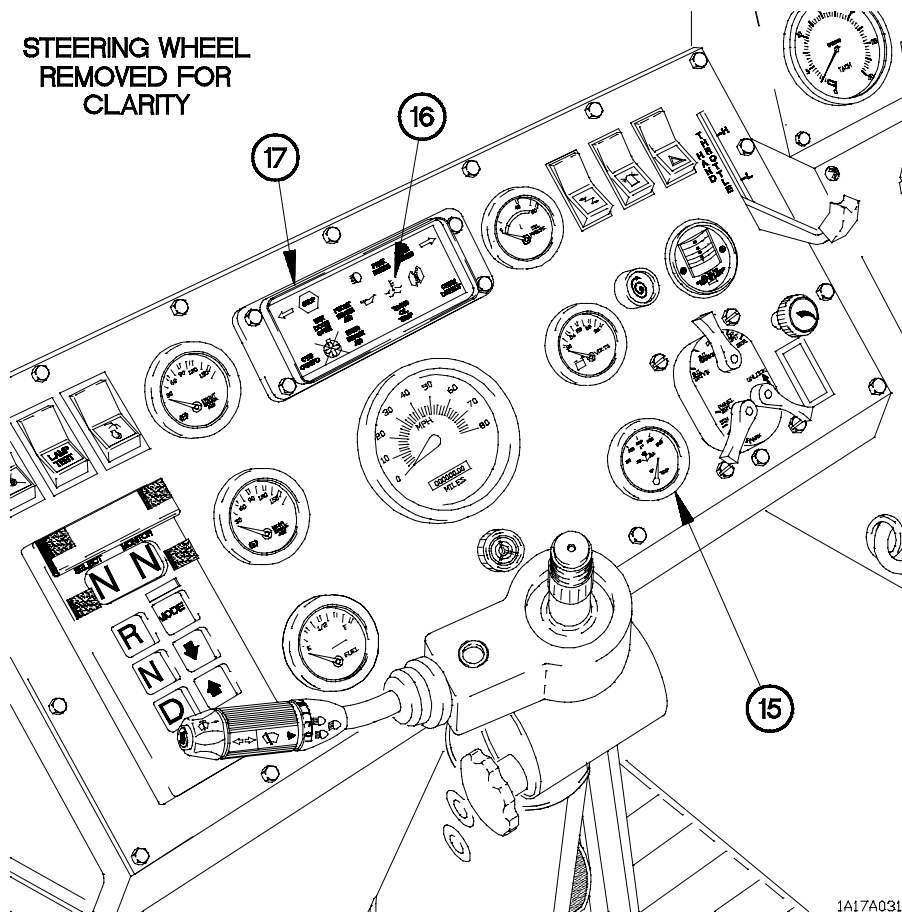


Figure 1-12. Cooling System (Cont)

(6) The WATER TEMP gage (15) on the instrument panel allows you to monitor coolant temperature. In addition, the high engine temperature indicator (16) on the lighted indicator display (17) illuminates when the coolant temperature exceeds 230°F (110°C). When the personnel heater is in use, warm coolant is used to heat the air in the cab before being returned to the radiator. Otherwise, coolant is returned directly to the radiator to be cooled.

1-18. ELECTRICAL SYSTEM

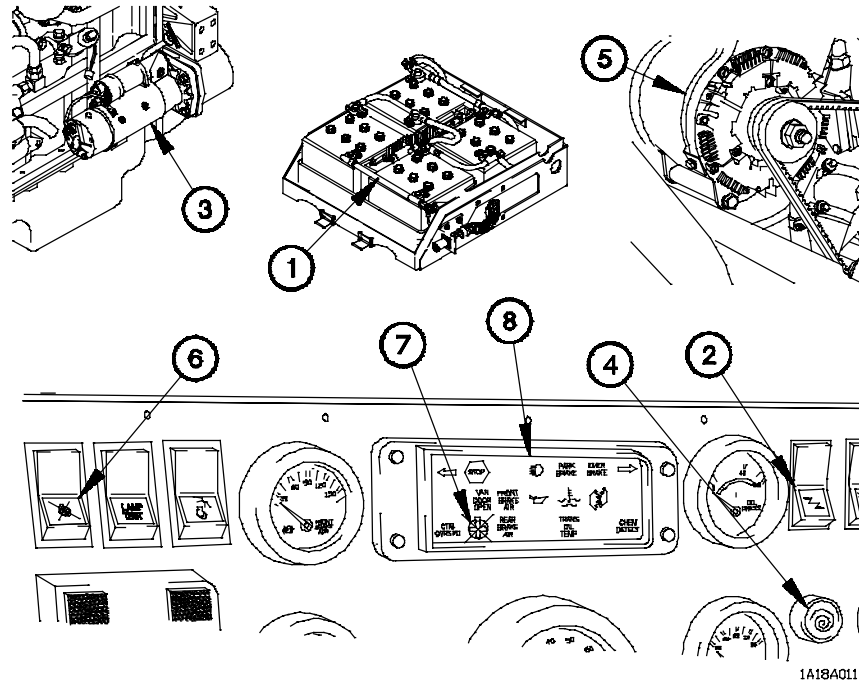


Figure 1-13. Electrical System

The vehicle Electrical System is a combined 12/24 vdc system. Four 12-volt batteries (1, Figure 1-13) are connected in series-parallel with the negative terminal grounded to the vehicle chassis.

- (1) Positioning the master power switch (2) to on applies power to all electrical circuits needed to operate the vehicle.
- (2) The starting motor (3) operates directly from the 24 vdc source through the starter pushbutton (4).
- (3) A 12/24-volt belt-driven alternator (5) with a 100 amp capacity maintains the charge on the batteries. The 24 vdc source supplies electrical power to operate the starting motor, CTIS, fuel/water separator, air dryer, ether injection system, instrument panel gages, and windshield wipers/ washer. The 12 vdc source supplies electrical power to the vehicle lights and instrument panel lights.
- (4) The radiator fan off switch (6) is used to keep the radiator fan from engaging. The fan off indicator (7) will illuminate on the lighted indicator display (8) when the radiator fan is disabled.

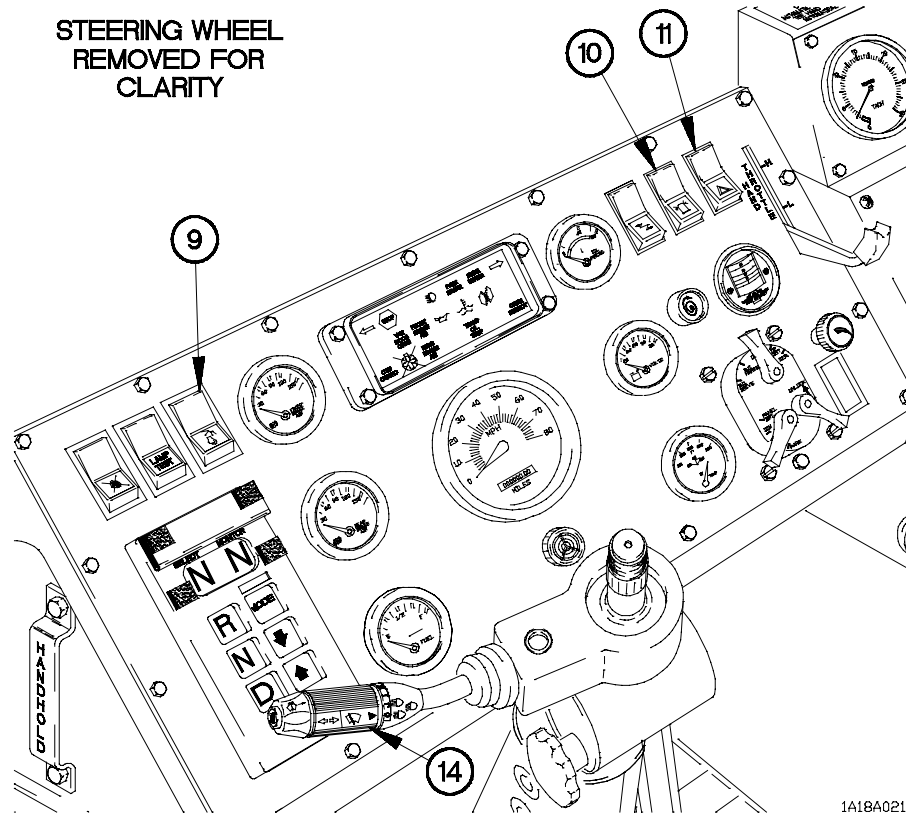


Figure 1-13. Electrical System (Cont)

(5) The ether start switch (9) is used to start the engine when the outside temperature is 32°F (0°C) or below. Pressing the ether start switch sends a measured charge of ether to the engine to make starting easier.

(6) The warning light switch (10) operates the amber warning light on the cab roof when installed.

(7) Positioning the hazard lights switch (11) to on causes both left and right turn signals to flash.

1-18. ELECTRICAL SYSTEM (CONT)

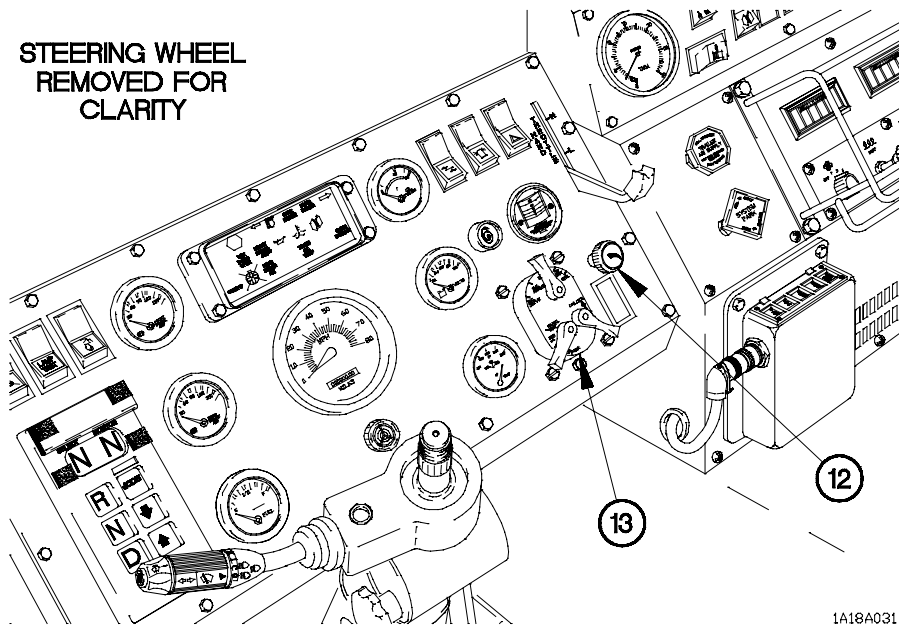


Figure 1-13. Electrical System (Cont)

(8) A dimmer switch (12) is provided so that you can adjust the brightness of the instrument panel lighting.

(9) The main light switch (13) is the only switch that is active even when the master power switch is off.

a. Positioning the main selector lever to SER DRIVE causes the headlights, taillights, marker lights, and clearance lights to illuminate; stoplights will illuminate when brake pedal is depressed.

b. Positioning the main selector lever to STOP LIGHT extinguishes all vehicle lights but allows stoplights to illuminate when brake pedal is depressed.

c. Positioning the auxiliary lever to PARK with the main selector lever in SER DRIVE causes the headlights to extinguish and the front parking lights to illuminate.

d. Positioning the main selector lever to BO MARKER causes the blackout marker lights to illuminate.

e. Positioning the main selector lever to BO DRIVE causes the blackout drive light and blackout marker lights to illuminate.

f. Instrument panel lights are illuminated when the main selector lever is in BRT position.

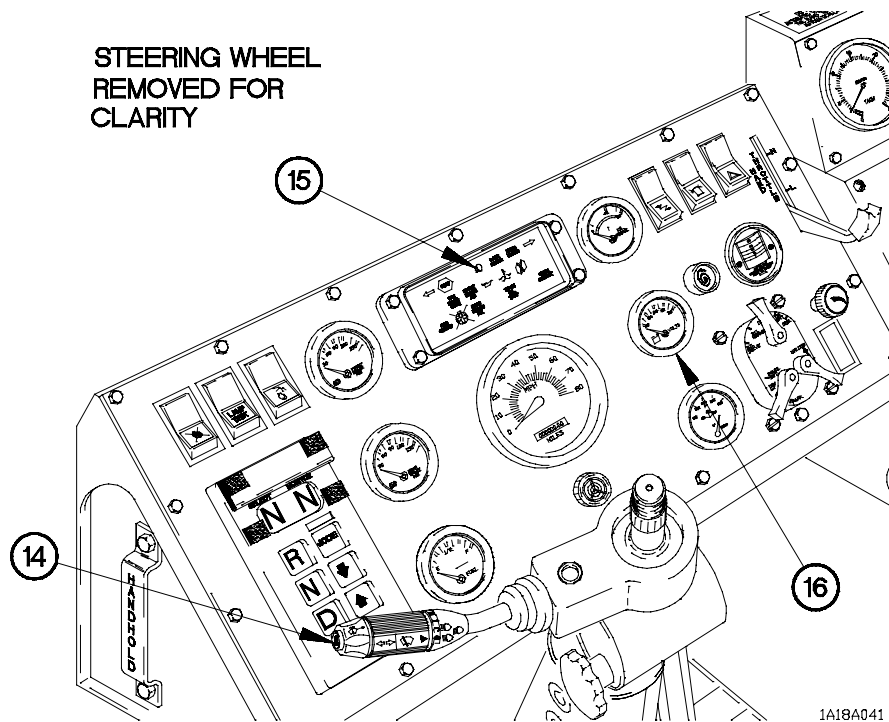
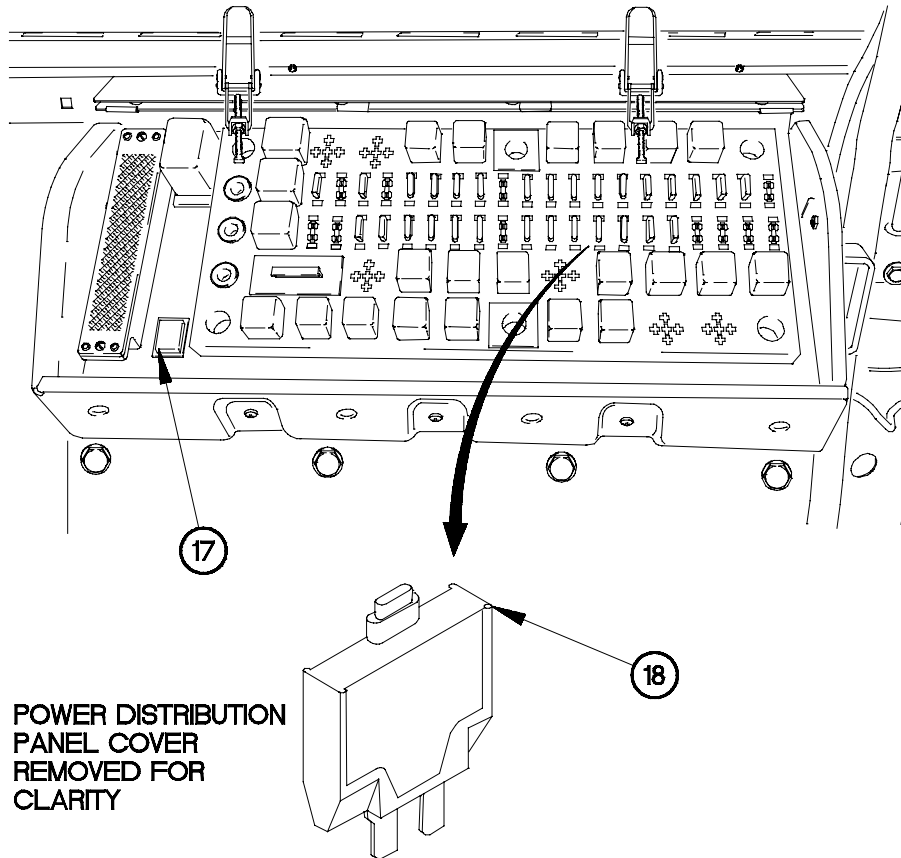


Figure 1-13. Electrical System (Cont)

- (10) Headlight high beams are controlled from the turn signal stalk (14).
- a. Pulling the turn signal stalk towards you will switch the headlights from low beam to high beam. The high beam indicator (15) will illuminate when your high beams are on.
 - b. Pulling the turn signal stalk again will switch the headlights from high beam to low beam.
- (11) The VOLTS gage (16) shows the voltage output for the 24 vdc system.

1-18. ELECTRICAL SYSTEM (CONT)



1A18A051

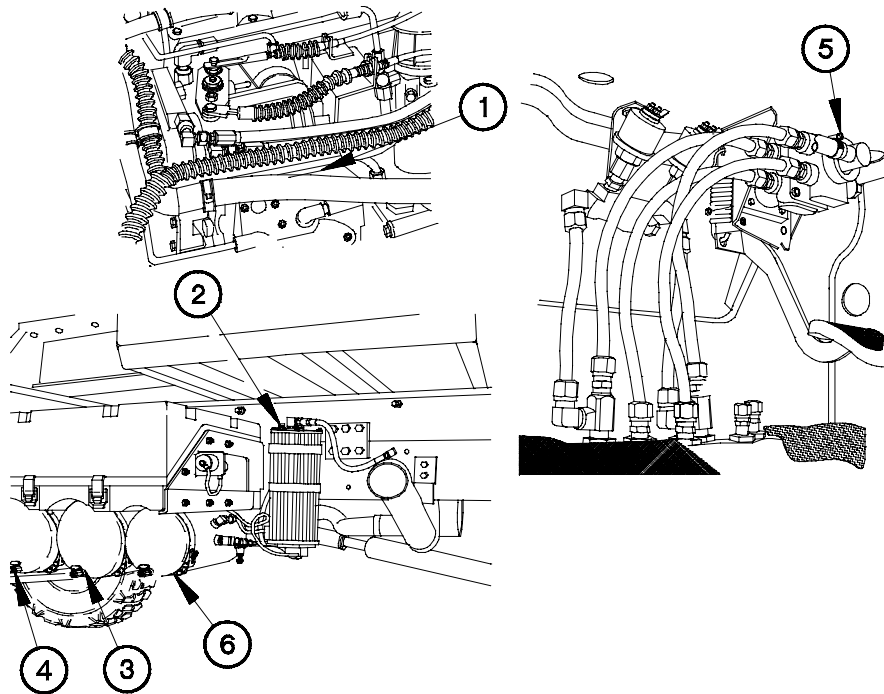
Figure 1-13. Electrical System (Cont)

(12) The start inhibit pushbutton (17) removes power from the fuel shutoff solenoid. When the master power switch is positioned to on and the start inhibit pushbutton is pressed, the engine will crank but will not start until the master power switch has been turned off and then turned back on again. The start inhibit pushbutton is to be used to assist with troubleshooting only. It is not intended to be used during maintenance.

(13) All electrical circuits are protected against overloads by circuit breakers (18).

(14) Wiring harnesses and electrical cable assemblies carry electrical current to operate equipment and accessories. Most electrical equipment and accessories are grounded directly to the vehicle chassis.

1-19. BRAKE SYSTEM



1A19A01A

Figure 1-14. Brake System

The vehicle is equipped with a brake system which complies with the Federal Motor Vehicle Safety Standard (FMVSS) 121. The brake system is made up of an air compressor, air dryer, primary and secondary air tanks, and several valves which control the application and release of the brakes.

(1) The air compressor (1, Figure 1-14) supplies approximately 120 psi (827 kPa) to the air dryer (2).

(2) The air dryer contains a heating element and a desiccant cartridge to remove moisture from the air before it is delivered to the primary air tank (3) and secondary air tank (4).

(3) The foot control valve (5) receives pressurized air from both the primary and secondary air tanks. The foot control valve is a two circuit design, with one set of ports directing air to the front brakes from the secondary air tank and a second set of ports directing air to the rear brakes from the primary air tank. The plumbing between the primary and secondary air tanks is designed to allow controlled braking in the event of a failure in either the primary (rear brakes) or secondary (front brakes) brake circuit. When air pressure in the wet tank (6) falls below a preset limit, pressurized air, normally used for the CTIS, is redirected to the primary brake circuit.

1-19. BRAKE SYSTEM (CONT)

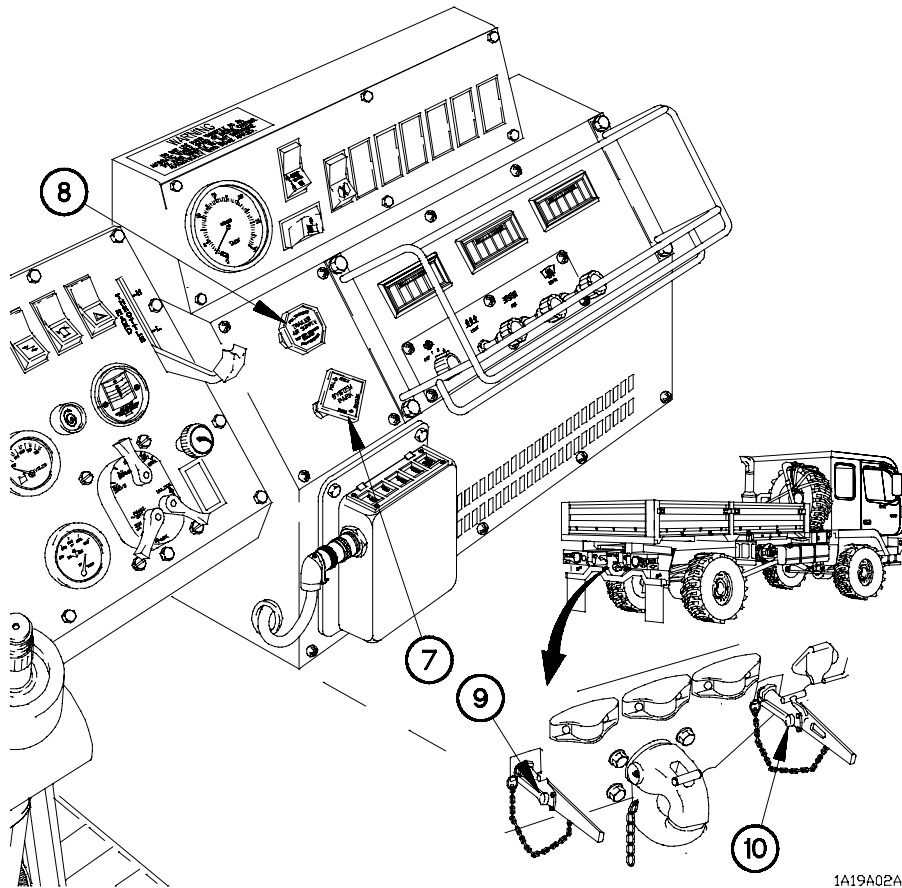
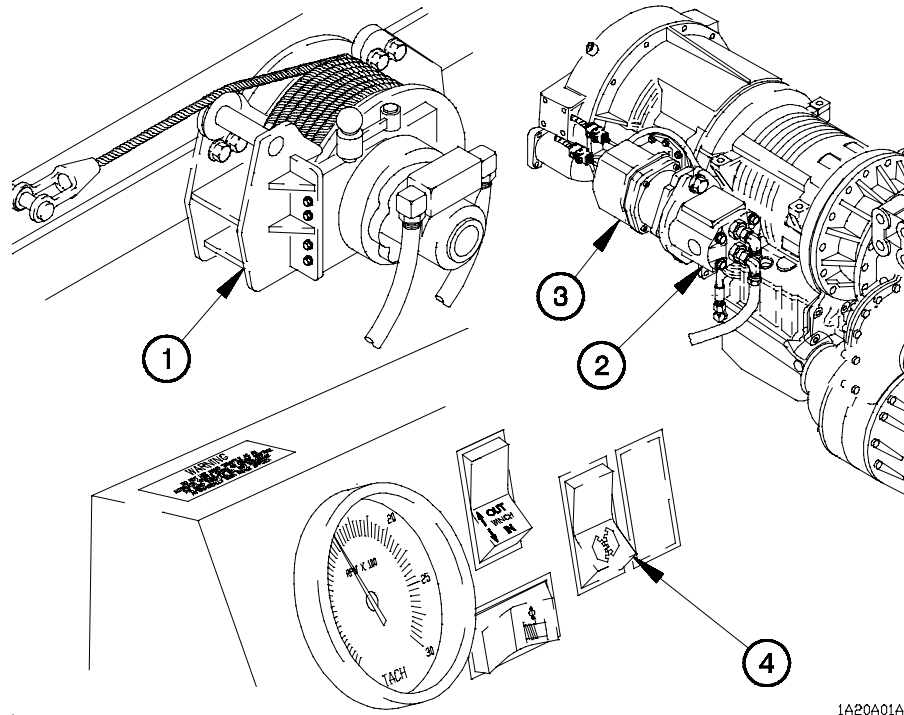


Figure 1-14. Brake System (Cont)

- (4) The SYSTEM PARK control (7) vents air pressure from the primary brake circuit and applies the rear spring brakes.
- (5) The TRAILER AIR SUPPLY control (8) supplies brake air pressure to a towed vehicle or trailer.
- (6) SERVICE gladhand (9) and EMERGENCY gladhand (10) provide the necessary connections to supply a towed vehicle or trailer with brake air pressure.

1-20. 11K SELF-RECOVERY WINCH (SRW)
--



1A20A01A

Figure 1-15. 11K Self-Recovery Winch (SRW)

a. 11K Self-Recovery Winch (SRW). When specified, any vehicle may be equipped with a 11K SRW (1) (Figure 1-15) mounted on the right hand frame rail. The 11K SRW is rated for 11,000 lbs (48,924 N) pull when the winch drum has one full layer of cable. Pulling capacity is reduced with each layer of cable added to the winch drum. One full layer of cable is the minimum amount of cable that may be left on the drum when using the 11K SRW. Pulling capacity with seven full layers of cable on the winch drum is 6,780 lbs (30,157 N). For recovery operations, the cable may be routed to the front or to the rear on all vehicles so equipped.

(1) Hydraulic pressure to operate the 11K SRW is supplied by a single stage hydraulic pump (2) mounted on the back of the PTO (3).

(2) Placing the PTO switch (4) in the on position causes the PTO drive gear to engage with the transmission. When the PTO is engaged, it drives the hydraulic pump.

1-20. 11K SELF-RECOVERY WINCH (SRW) (CONT)

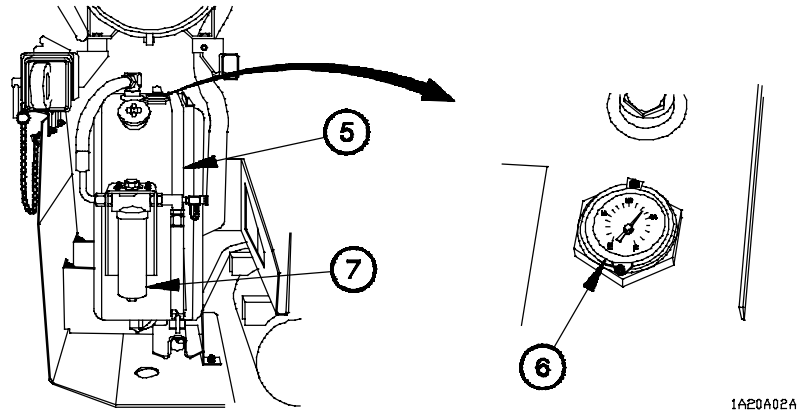


Figure 1-15. 11K Self-Recovery Winch (SRW) (Cont)

b. Hydraulic Reservoir. The hydraulic reservoir (5) is mounted on the left hand frame rail and contains the oil needed to operate the 11K SRW. The hydraulic reservoir holds 27 gal (102 L) of oil and is equipped with an oil gage (6). A fluid filter (7) is also mounted on the hydraulic reservoir to remove contaminants.

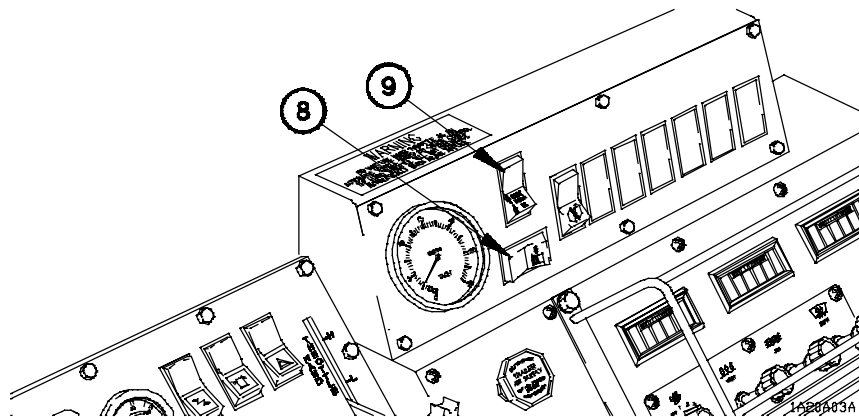


Figure 1-15. 11K Self-Recovery Winch (SRW) (Cont)

- (1) When the winch switch (8) is turned on, hydraulic power is supplied to the 11K SRW and the transmission is locked in neutral.
- (2) The cable can be payed out or reeled in by pressing the WINCH IN/OUT switch (9).

1-21. AIR SYSTEM

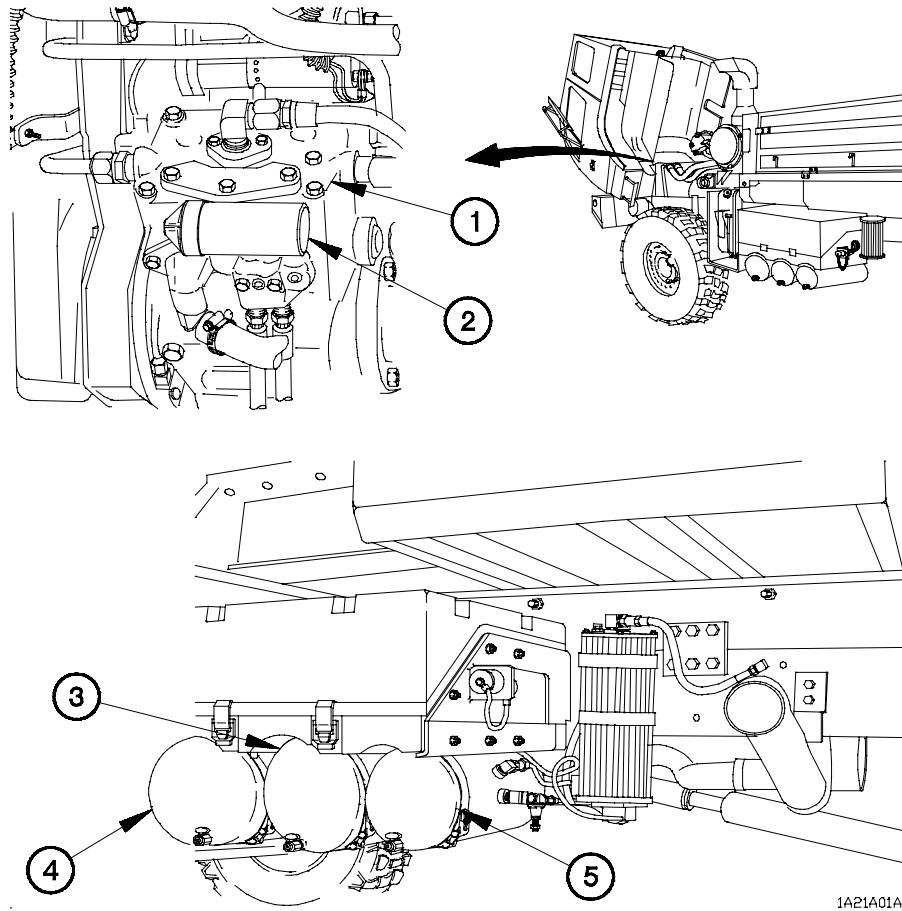


Figure 1-16. Air System

The Air System provides clean, dry air for use in the air brake system and the CTIS.

(1) The air system is pressurized by an engine driven air compressor (1, Figure 1-16) with an average output pressure of 125 psi (862 kPa). The system pressure is controlled by a pressure governor (2) which maintains the output pressure between 105-125 psi (724-862 kPa).

(2) Air is supplied to the air brake portion of the system by the primary air tank (3) and secondary air tank (4). Air for the CTIS comes from the wet tank (5).

1-21. AIR SYSTEM (CONT)

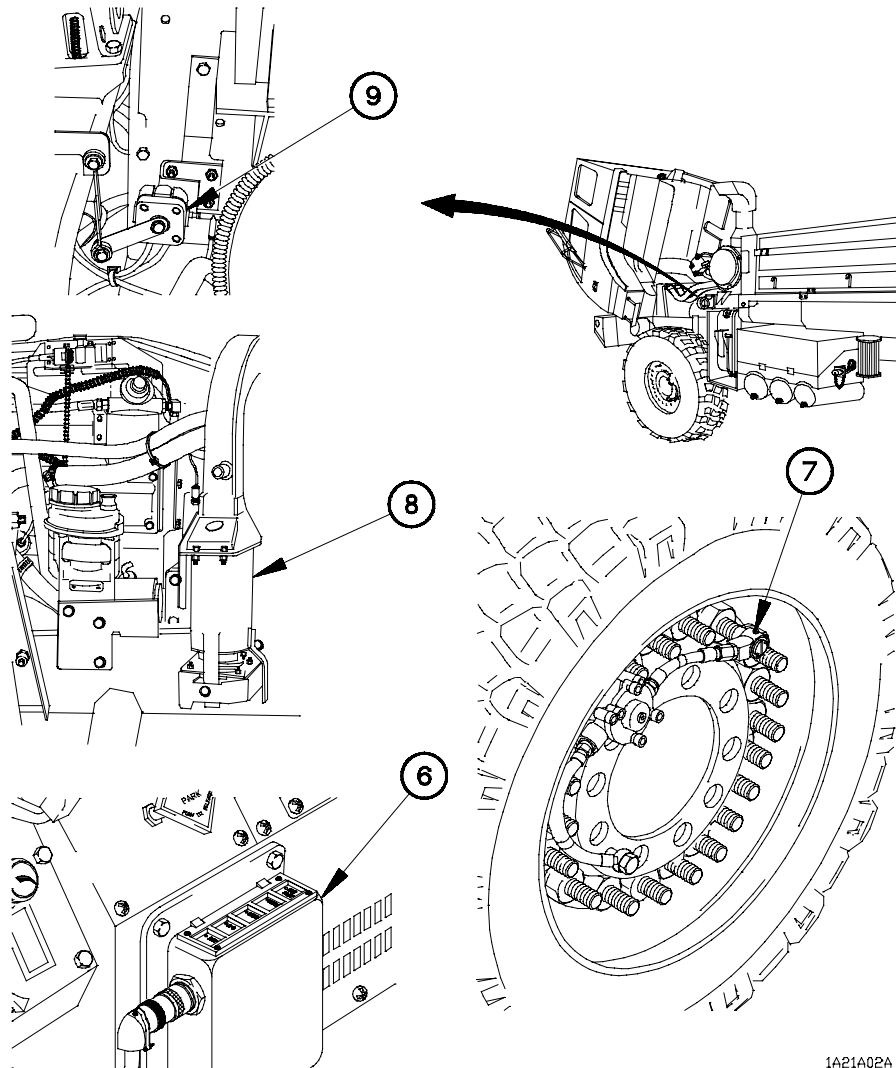


Figure 1-16. Air System (Cont)

(3) Air pressure in the tires is controlled by the CTIS ECU (6). The CTIS ECU provides for five tire pressure settings which are: highway, cross-country, sand, emergency, and run-flat. Kneeling valves (7) on the front tires allow the front of the vehicle to be lowered for internal air transport (C-130 and C-141). Air pressure is also used to keep the cab level through the use of air springs (8), mounted below the rear cab support, and a cab leveling valve (9).

CHAPTER 2 OPERATING INSTRUCTIONS

Section I. DESCRIPTION AND USE OF OPERATOR'S CONTROLS AND INDICATORS	2-3
2-1. INSTRUMENT PANEL CONTROLS AND INDICATORS	2-3
2-2. AUXILIARY PANEL CONTROLS AND INDICATORS	2-13
2-3. CENTER CONSOLE CONTROLS AND INDICATORS	2-14
2-4. STEERING COLUMN CONTROLS	2-17
2-5. FLOOR-MOUNTED CONTROLS	2-18
2-6. DOOR-MOUNTED CONTROLS	2-19
2-7. SEAT CONTROLS	2-20
2-8. EXTERIOR CONTROLS AND INDICATORS	2-21
2-9. SPECIAL PURPOSE KIT CONTROLS AND INDICATORS	2-24
2-10. M1079 VAN CONTROLS	2-27
Section II. PREVENTIVE MAINTENANCE CHECKS AND SERVICES (PMCS)	2-30
2-11. PMCS INTRODUCTION	2-30
2-12. PMCS PROCEDURES	2-30
2-13. GENERAL MAINTENANCE INSTRUCTIONS	2-31
2-14. FLUID LEAKAGE	2-32
2-15. PREVENTIVE MAINTENANCE CHECKS AND SERVICES TABLE (ALL MODELS)	2-33
2-16. PREVENTIVE MAINTENANCE CHECKS AND SERVICES TABLE (M1078 AND M1081)	2-93
2-17. PREVENTIVE MAINTENANCE CHECKS AND SERVICES TABLE (M1081 AIR DROP SPECIFIC)	2-110
2-18. PREVENTIVE MAINTENANCE CHECKS AND SERVICES TABLE (M1079)	2-117
Section III. OPERATION UNDER USUAL CONDITIONS	2-126
2-19. M1079 VAN PREPARATION FOR MOVEMENT	2-126
2-20. PREPARATION FOR USE	2-127
2-21. VEHICLE OPERATION	2-134
2-22. RAISING/LOWERING CAB	2-164
2-23. CENTRAL TIRE INFLATION SYSTEM (CTIS) OPERATION	2-170
2-24. LIGHT MATERIAL HANDLING CRANE (LMHC) OPERATION	2-176
2-25. HEATER/DEFROST OPERATION	2-206
2-26. LADDERS, SIDE PANELS, AND STAKES OPERATION	2-208
2-27. CARGO COVER KIT INSTALLATION/REMOVAL	2-215
2-28. CARGO COVER FLAP OPERATION	2-236
2-29. TROOPSEAT KIT LOWERING/RAISING	2-244
2-30. M1079 VAN LADDER MOUNTING/STOWAGE	2-248
2-31. M1079 VAN DOOR OPENING/CLOSING	2-255
2-32. M1079 VAN AC POWER CONNECTION/DISCONNECTION	2-259
2-33. M1079 VAN WINDOW OPERATION	2-266
2-34. M1079 VAN LIGHTING	2-269
2-35. M1079 VAN FAN OPERATION	2-271
2-36. M1079 VAN 24 VDC BINDING POST OPERATION	2-272

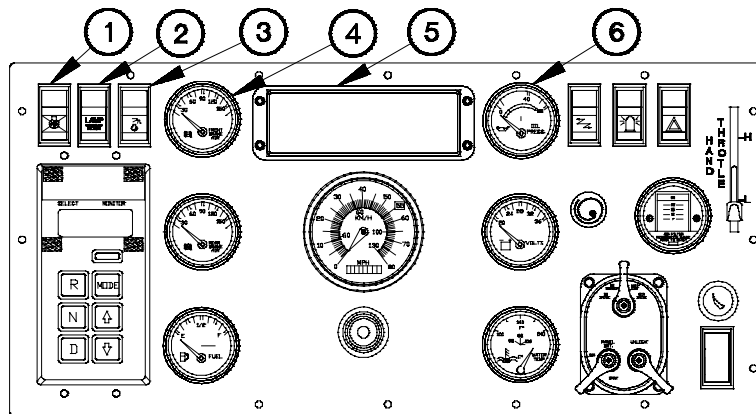
TM 9-2320-365-10

2-37.	M1079 VAN FIELD PHONE BINDING POST OPERATION	2-273
2-38.	M1079 VAN 12/24 VDC POWER CONNECTION/DISCONNECTION	2-274
2-39.	M1079 VAN AIR CONDITIONER/HEATER OPERATION	2-275
2-40.	AUXILIARY EQUIPMENT OPERATION	2-276
2-41.	BACK-UP HYDRAULIC PUMP OPERATION	2-280
2-42.	DATA AND INSTRUCTION PLATES	2-282
Section IV. OPERATION UNDER UNUSUAL CONDITIONS		2-292
2-43.	OPERATION IN EXTREME HEAT	2-292
2-44.	OPERATION IN EXTREME DUST	2-295
2-45.	OPERATION IN FOREST OR ON ROCKY TERRAIN	2-297
2-46.	OPERATION IN SAND OR MUD	2-298
2-47.	OPERATION IN DESERT ENVIRONMENT	2-300
2-48.	FIRE EXTINGUISHER OPERATION	2-301
2-49.	HIGHWAY EMERGENCY MARKER KIT SETUP	2-302
2-50.	TOWBAR CONNECTION/DISCONNECTION	2-307
2-51.	TOWING DISABLED VEHICLE	2-320
2-52.	DELETED	
2-53.	DELETED	
2-54.	11K SELF-RECOVERY WINCH (SRW) OPERATION	2-329
2-55.	DELETED	
2-56.	EMERGENCY PROCEDURES	2-355
2-57.	PREPARATION FOR SHIPMENT	2-361
2-58.	PREPARATION FOR INTERNAL AIR TRANSPORT	2-362
2-59.	RAPID ENGINE WARM-UP	2-376
2-60.	PREPARATION FOR MACHINE GUN OPERATION	2-405
2-61.	AMBER WARNING LIGHT KIT INSTALLATION/REMOVAL	2-408
2-62.	STARTING ON HILL OPERATION	2-408
2-63.	TIRE CHAINS INSTALLATION/REMOVAL	2-409
2-64.	VEHICLE OPERATION IN COLD ENVIRONMENT, 32°F TO -25°F (0°C TO -32°C).	2-413
2-65.	DELETED	

Section I. DESCRIPTION AND USE OF OPERATOR'S CONTROLS AND INDICATORS

2-1. INSTRUMENT PANEL CONTROLS AND INDICATORS

a. **Instrument Panel.** Figure 2-1 shows all controls and indicators on the Instrument Panel.



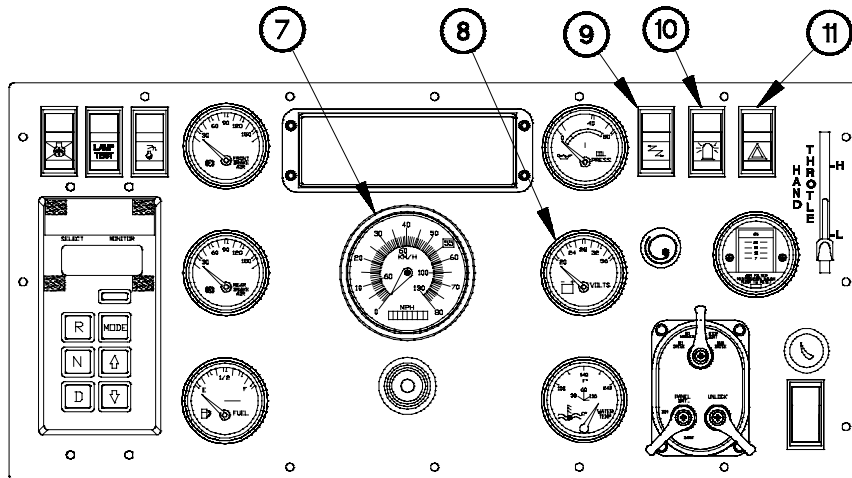
STEERING WHEEL
REMOVED FOR CLARITY

1B01A011

Figure 2-1. Instrument Panel Controls and Indicators

1. **Radiator Fan Off Switch.** When positioned to on, radiator fan off switch will illuminate to indicate the radiator fan is disabled. Radiator fan off switch will remain in the off position and not illuminated, unless otherwise directed.
2. **Lamp Test Switch.** Tests the lights on high engine temperature and TRANS OIL TEMP indicators on Lighted Indicator Display.
3. **Ether Start Switch.** Injects ether into engine intake system to assist with cold weather starting when switch is pressed.
4. **FRONT BRAKE AIR Pressure Gauge.** Shows air pressure (in psi) available to operate front brakes. Normal air pressure range is 65-120 psi (448-827 kPa).
5. **Lighted Indicator Display.** Indicator lights to indicate operating characteristics of the vehicle. Figure 2-2 shows all indicators on the Lighted Indicator Display.
6. **OIL PRESS Gauge.** Shows engine oil pressure (in psi). Normal oil pressure range is 15-80 psi (103-552 kPa).

2-1. INSTRUMENT PANEL CONTROLS AND INDICATORS (CONT)

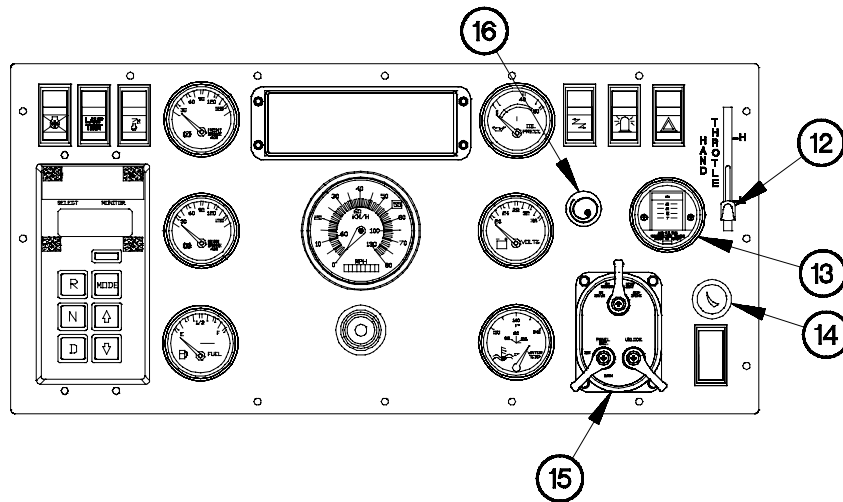


STEERING WHEEL
REMOVED FOR CLARITY

1B01A021

Figure 2-1. Instrument Panel Controls and Indicators (Cont)

7. **Speedometer/Odometer.** Speedometer shows vehicle speed in miles per hour (mph) and kilometers per hour (km/h). Odometer indicates number of miles the vehicle has traveled.
8. **VOLTS Gage.** Shows battery output voltage when engine is not running and alternator output voltage when engine is running.
9. **Master Power Switch.** Controls electrical power for engine starting and/or electrical system operation.
10. **Amber Warning Light Switch.** Operates vehicle amber warning light when main light switch is positioned to SER DRIVE and vehicle is equipped with warning light kit.
11. **Hazard Lights Switch.** Operates hazard lights. Left and right turn signals and indicators flash when switch is on.



STEERING WHEEL
REMOVED FOR CLARITY

1B01A031

Figure 2-1. Instrument Panel Controls and Indicators (Cont)

WARNING

Do not use **HAND THROTTLE** lever while driving vehicle. The **HAND THROTTLE** lever is not to be used as a cruise control. Failure to comply may result in serious injury or death to personnel or damage to equipment.

12. **HAND THROTTLE Lever.** Adjusts engine speed to assist with engine warm up and to set engine rpm when using the Power Take-Off (PTO).
13. **AIR FILTER RESTRICTION GAUGE.** Indicates when air filter is restricted. Diaphragm enters red zone when air filter is clogged and needs service. RESET button on face of gauge can be pressed to reset gauge after air cleaner is serviced.
14. **Dimmer Switch.** Controls brightness of instrument panel lighting. Turn control left to increase brightness, right to decrease brightness.
15. **Main Light Switch.** Controls service and blackout lights. Figure 2-3 shows all controls on the main light switch.
16. **Starter Pushbutton.** Starts engine. Starter pushbutton operates only when master power switch is in the on position.

2-1. INSTRUMENT PANEL CONTROLS AND INDICATORS (CONT)

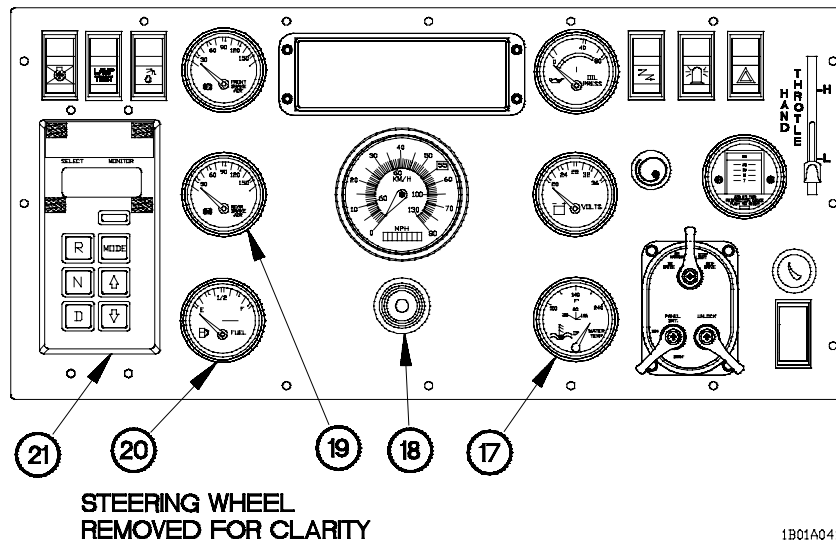


Figure 2-1. Instrument Panel Controls and Indicators (Cont)

- 17. **WATER TEMP Gage.** Shows engine coolant temperature in degrees Fahrenheit. Normal temperature range is 165-230° F (74° C - 110° C).
- 18. **Audible Alarm.** A steady tone sounds when air pressure is below 65 psi (448 kPa). A wavering (dual tone) sounds when troop transport alarm switch is activated (on vehicles with troopseat kits). A steady tone sounds when M1079 Van body door is open.
- 19. **REAR BRAKE AIR Pressure Gage.** Shows air pressure (in psi) available to operate rear brakes. Normal air pressure range is 65-120 psi (448 -827 kPa).
- 20. **FUEL Gage.** Shows fuel level in fuel tank.
- 21. **WTEC II Transmission ECU Pushbutton Shift Selector (TEPSS).** Used to select forward or reverse range, to set highest gear range, to switch from highway to off-road mode, and to monitor transmission operation. Figure 2-4 shows all controls and indicators on the WTEC II TEPSS. Figure 2-5 shows all controls and indicators on the WTEC III Transmission Pushbutton Shift Selector (TPSS).

b. **Lighted Indicator Display.** Figure 2-2 shows all indicators on the lighted indicator display.

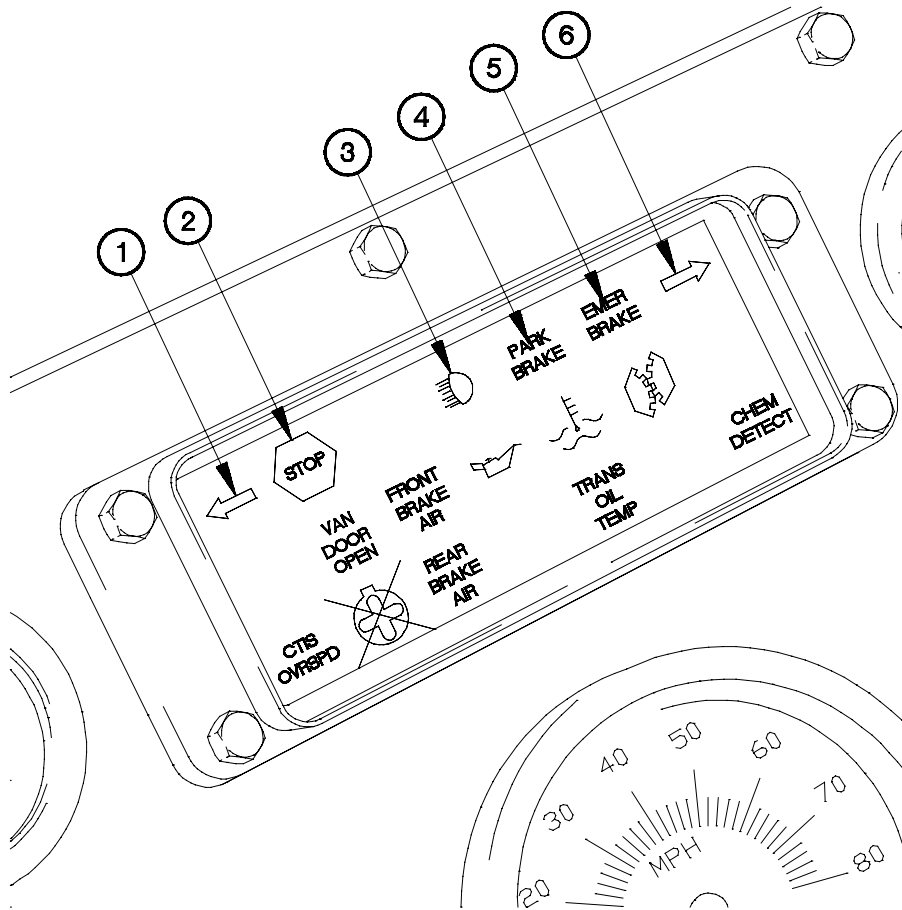


Figure 2-2. Lighted Indicator Display

1. **Left Turn Signal.** Flashes (green) when left turn signal is on.
2. **STOP Indicator.** Illuminates (red) when low engine oil pressure, high water temperature, front or rear air brake pressure is low, or M1079 van door is open.
3. **High Beams ON Indicator.** Illuminates (green) when high beam headlights are on.
4. **PARK BRAKE Indicator.** Illuminates (amber) when parking brake is applied.
5. **EMER BRAKE Indicator.** Illuminates (amber) when SYSTEM PARK control is applied.
6. **Right Turn Signal.** Flashes (green) when right turn signal is on.

2-1. INSTRUMENT PANEL CONTROLS AND INDICATORS (CONT)

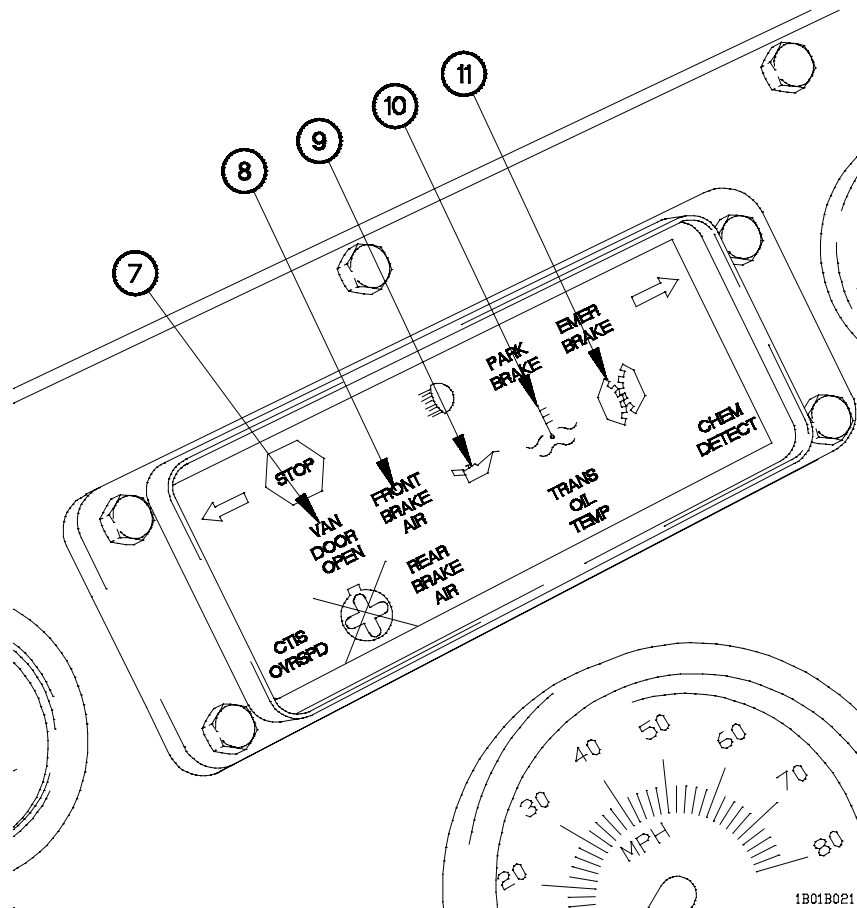


Figure 2-2. Lighted Indicator Display (Cont)

- 7. **VAN DOOR OPEN Indicator.** Flashes (amber) when M1079 van door is open.
- 8. **FRONT BRAKE AIR Indicator.** Illuminates (red) when air pressure for the front service brakes drops below 65 psi (448 kPa). Audible alarm sounds and STOP indicator illuminates when FRONT BRAKE AIR indicator is on.
- 9. **Engine Oil Pressure Indicator.** Illuminates (red) when engine oil pressure drops below 12 psi (83 kPa). STOP indicator illuminates when engine oil pressure indicator is on.
- 10. **High Engine Temperature Indicator.** Illuminates (red) when engine coolant temperature is greater than 230° F (110° C).
- 11. **Power Take-Off (PTO) On Indicator.** Illuminates (green) when PTO is engaged.

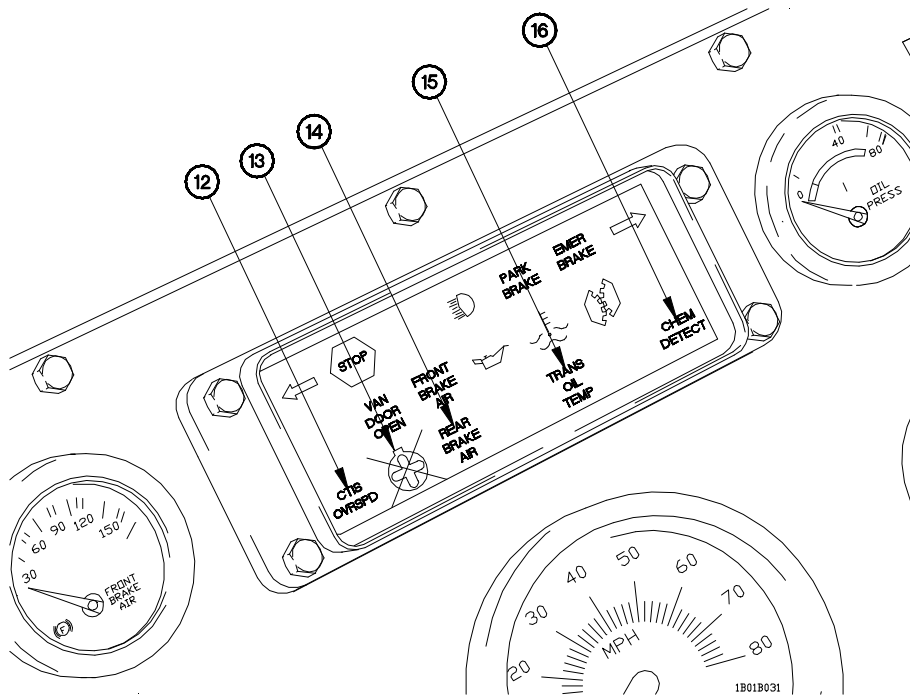
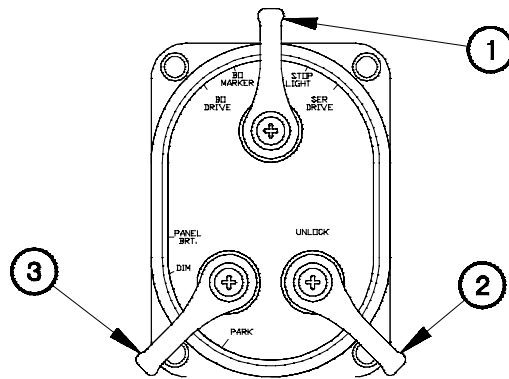


Figure 2-2. Lighted Indicator Display (Cont)

- 12. CTIS OVRSPD Indicator.** Illuminates (amber) when vehicle speed exceeds safe limit for selected tire inflation pressure.
- 13. Fan Off Indicator.** Illuminates (amber) when the radiator fan is disabled for fording. Indicates the radiator fan off switch is on.
- 14. REAR BRAKE AIR Indicator.** Illuminates (red) when air pressure for the rear service brakes drops below 65 psi (448 kPa). Audible alarm sounds and STOP indicator illuminates when REAR BRAKE AIR indicator is on.
- 15. TRANS OIL TEMP Indicator.** Illuminates (red) when transmission oil temperature is greater than 225 F (107 C).
- 16. CHEM DETECT Indicator.** Illuminates (red) when M43 chemical detector senses a chemical agent. M42 alarm sounds when CHEM DETECT indicator is on.

2-1. INSTRUMENT PANEL CONTROLS AND INDICATORS (CONT)

c. **Main Light Switch.** Figure 2-3 shows all controls on the main light switch.



1B01C011

Figure 2-3. Main Light Switch

- 1. Main Selector Lever.** Controls operation of service and blackout lights.
 - a. All blackout lights operate when main selector lever is positioned to BO DRIVE.
 - b. Blackout marker lights operate when main selector lever is positioned to BO MARKER.
 - c. Stoplights operate when main selector lever is positioned to STOP LIGHT and brake pedal is pressed.
 - d. All service drive lights operate when main selector lever is positioned to SER DRIVE.
 - e. No exterior lights operate when main selector lever is positioned to OFF.
- 2. UNLOCK Lever.** Locks main light switch. UNLOCK lever must be lifted and held in order to place main selector lever in any position except BO MARKER.
- 3. Auxiliary Lever.** Controls operation of parking lights.
 - a. Operates parking lights when auxiliary lever is positioned to PARK and main selector lever is positioned to SER DRIVE.
 - b. PANEL BRT position allows adjustment of instrument panel illumination by using the dimmer switch.
 - c. DIM position sets instrument panel illumination to its lowest setting and does not allow use of the dimmer switch.

d. **WTEC II Transmission ECU Pushbutton Shift Selector (TEPSS).** Figure 2-4 shows all controls and indicators on the WTEC II TEPSS.

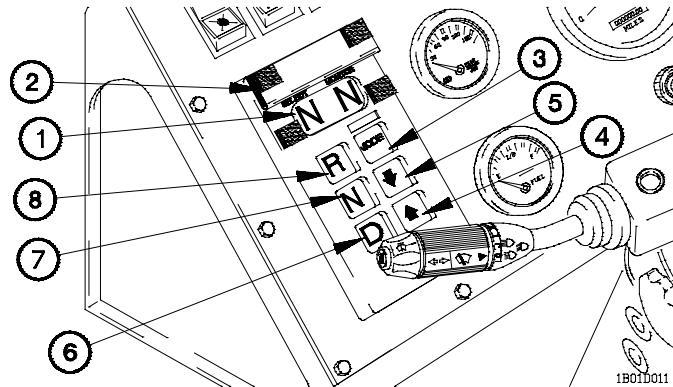


Figure 2-4. WTEC II Transmission ECU Pushbutton Shift Selector (TEPSS)

1. **LED Display.** Displays the following information:
 - a. Forward gear selected (shown in left side of LED display).
 - b. Current forward gear (shown in right side of LED display).
 - c. Operating mode (blank for highway mode, MODE ON displayed when off-road mode is selected).
 - d. DELETED
2. **WTEC II TEPSS Blackout Filter Cover.** Used to cover LED display during blackout conditions.
3. **MODE Select Button.** Switches transmission between highway mode and off-road mode.
4. **Up Arrow Button.** Switches transmission to next higher forward gear or to select maximum forward gear.
5. **Down Arrow Button.** Switches transmission to next lower forward gear or to downshift into first gear.
6. **D Range Button.** Switches transmission to Drive. Automatically selects seventh gear as maximum forward gear. Second gear is the lowest gear available. First gear is available only as a manual selection.
7. **N Range Button.** Switches transmission to Neutral.
8. **R Range Button.** Switches transmission to Reverse.

2-1. INSTRUMENT PANEL CONTROLS AND INDICATORS (CONT)

e. **WTEC III Transmission Pushbutton Shift Selector (TPSS).** Figure 2-5 shows all controls and indicators on the WTEC III TPSS.

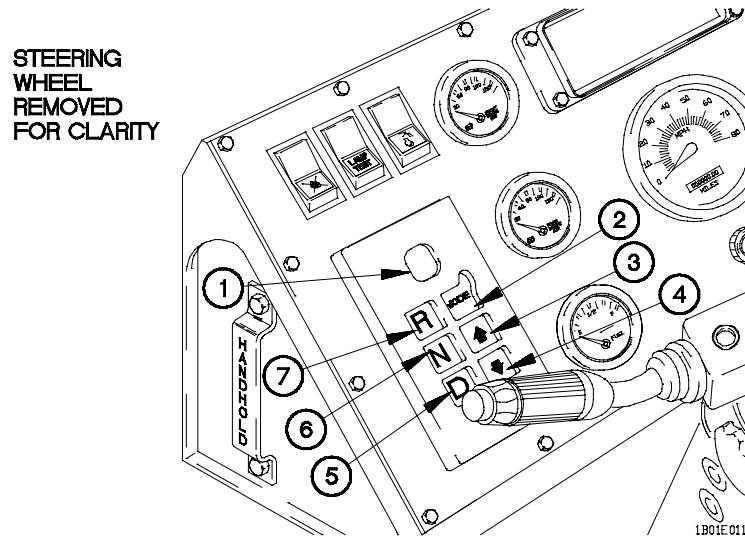
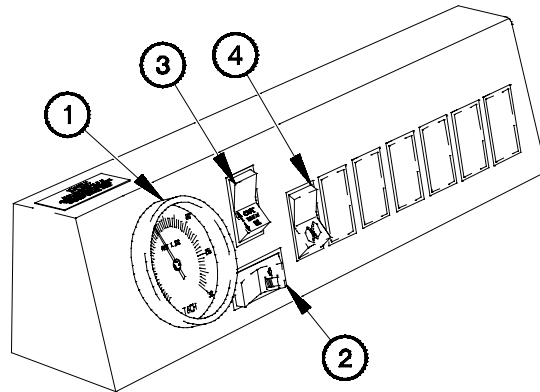


Figure 2-5. WTEC III Transmission Pushbutton Shift Selector (TPSS)

1. **LED Display.** Displays the following information:
 - a. R - Reverse gear selected.
 - b. N - Neutral (no gear selection mode or transmission placed in Neutral).
 - c. 1 through 7 - current forward gear selected.
2. **MODE Select Button.** Switches transmission between highway mode and off-road mode.
3. **Up Arrow Button.** Switches transmission to next higher forward gear or to select maximum forward gear.
4. **Down Arrow Button.** Switches transmission to next lower forward gear or to downshift into first gear.
5. **D Range Button.** Switches transmission to Drive. Automatically selects seventh gear as maximum forward gear. Second gear is the lowest gear available. First gear is available only as a manual selection.
6. **N Range Button.** Switches transmission to Neutral.
7. **R Range Button.** Switches transmission to Reverse.

2-2. AUXILIARY PANEL CONTROLS AND INDICATORS

a. Auxiliary Panel Controls and Indicators. Figure 2-6 shows all controls and indicators that may be located on the auxiliary panel. Some switch locations may be blank depending on the model of your vehicle.



1b02a01b

Figure 2-6. Auxiliary Panel Controls and Indicators

1. **TACH (Tachometer) (Models with Power Take-Off (PTO)).** Shows speed of engine crankshaft in revolutions per minute (rpm x 100). Tachometer is used to monitor engine speed during PTO operation.
2. **Winch Switch (Models with 11K Self-Recovery Winch [SRW]).** Locks transmission in Neutral for self-recovery operation.
3. **WINCH IN/OUT Switch (Models with 11K Self-Recovery Winch [SRW]).** Controls reel in/pay out of cable. PTO switch must be positioned to on before WINCH IN/OUT switch will operate. Push top half of switch to pay out cable, bottom half of switch to reel in cable.
4. **PTO Switch (Models with PTO).** Controls operation of PTO.
5. DELETED
6. DELETED
7. DELETED

2-3. CENTER CONSOLE CONTROLS AND INDICATORS

a. **Air System Controls.** Figure 2-7 shows all air system controls on the center console.

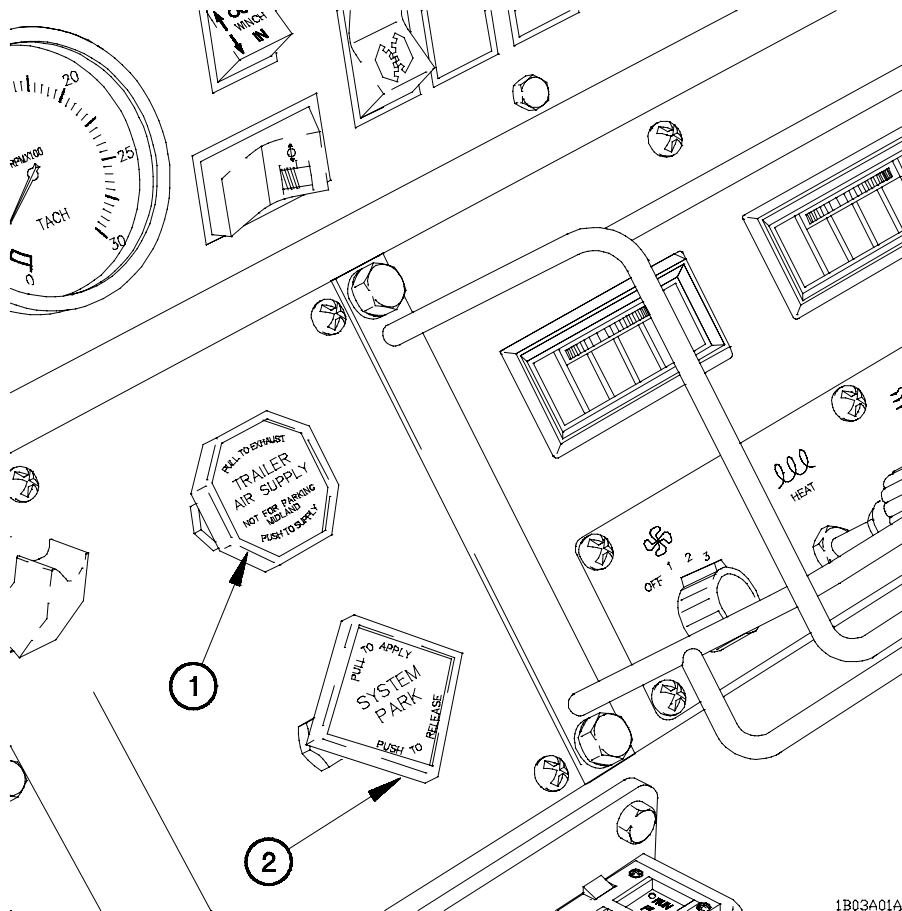
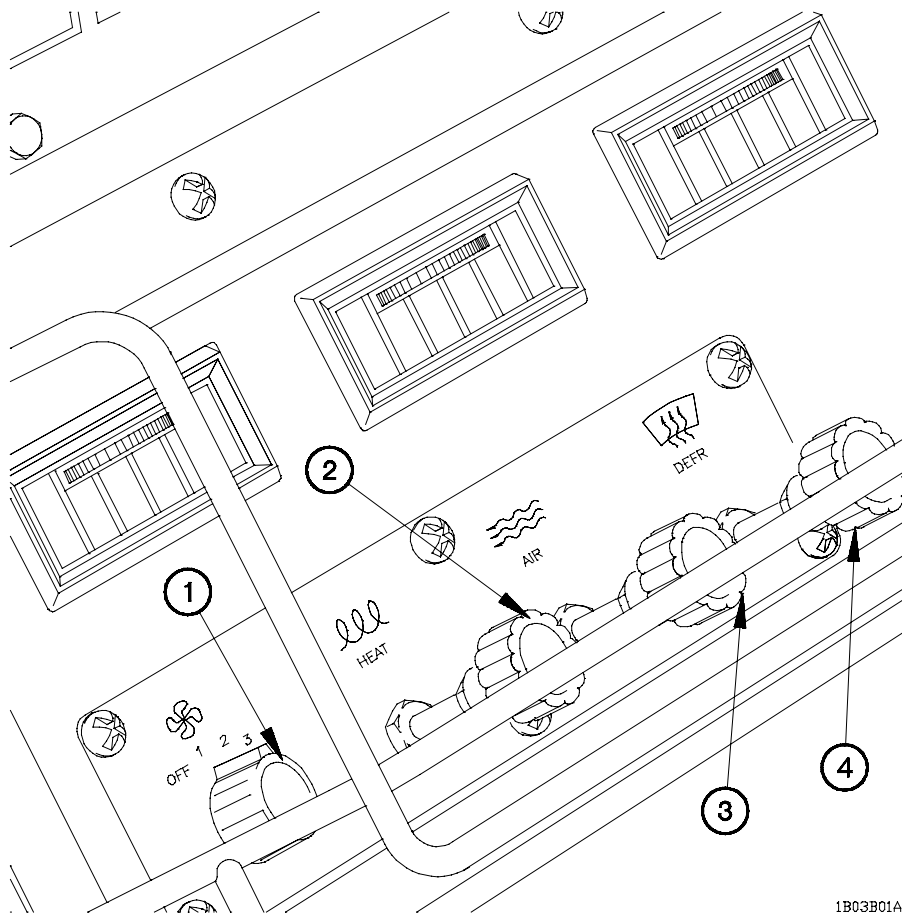


Figure 2-7. Air System Controls

1. **TRAILER AIR SUPPLY Control.** Controls air supply to trailer brakes. Air is supplied to trailer when control is pushed in.
2. **SYSTEM PARK Control.** Applies and releases the parking brakes and trailer parking brakes (if equipped). Parking brakes are applied when control is pulled.

b. **Heater/Defrost Controls.** Figure 2-8 shows all heater/defrost controls on the center console.



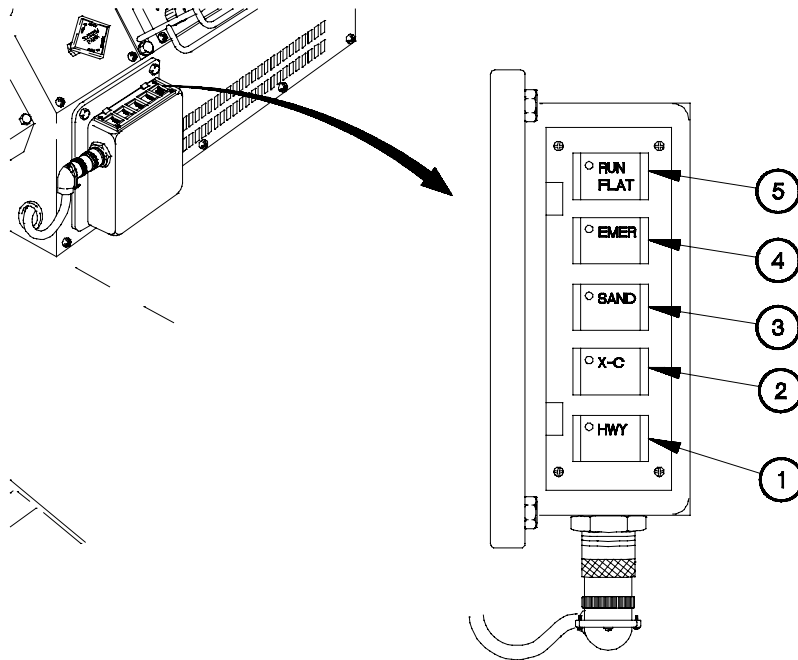
1B03B01A

Figure 2-8. Heater/Defrost Controls

1. **Fan Switch.** Four-position switch used to control operation and speed of heater fan.
2. **HEAT Control.** Controls temperature of air that heats cab interior and defrosts windshield. Temperature of air increases when control is pulled.
3. **VENT Control.** Controls flow of outside air to cab. When control is pulled, fresh air is vented into cab.
4. **DEFR (Defrost) Control.** Controls windshield defrosting. Air is routed from heater to defrost windshield when control is pulled.

2-3. CENTER CONSOLE CONTROLS AND INDICATORS (CONT)

c. **CTIS Electronic Control Unit (ECU).** Figure 2-9 shows all CTIS controls and indicators on the center console.



1B03C011

Figure 2-9. Central Tire Inflation System (CTIS) Electronic Control Unit (ECU) Controls and Indicators

1. **HWY (Highway) Mode Button and Indicator.** Pressed to set CTIS in highway mode. Indicator illuminates steady when tire pressure is 55 psi (379 kPa). Maximum speed is 55 mph (88 km/h) in HWY mode.
2. **X-C (Cross-Country) Mode Button and Indicator.** Pressed to set CTIS in cross-country mode. Indicator illuminates steady when tire pressure is 33 psi (228 kPa). Maximum speed is 40 mph (64 km/h) in X-C mode.
3. **SAND (Soft Terrain) Mode Button and Indicator.** Pressed to set CTIS in soft terrain mode. Indicator illuminates steady when tire pressure is 20 psi (138 kPa). Maximum speed is 12 mph (19 km/h) in SAND mode.
4. **EMER (Emergency) Mode Button and Indicator.** Pressed to set CTIS in emergency mode. Indicator illuminates steady when tire pressure is 14 psi (97 kPa). Maximum speed is 5 mph (8 km/h) in EMER mode.
5. **RUN FLAT Mode Button and Indicator.** Mode used to maintain tire air pressure in the event of a leak.

2-4. STEERING COLUMN CONTROLS

Figure 2-10 shows all controls on the steering column.

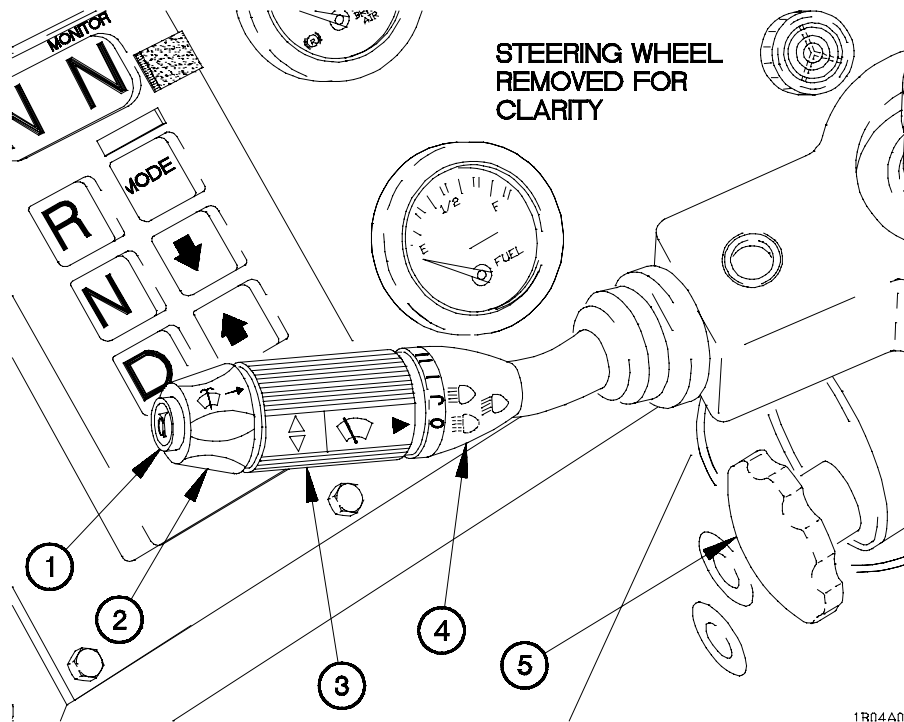


Figure 2-10. Steering Column Controls

1. **Horn Button.** Sounds horn when pressed.
2. **Windshield Washer Switch.** Activates windshield washer when pushed in.
3. **Windshield Wiper Switch.** Four-position switch used to operate and control the speed of the windshield wipers. Windshield wipers operate intermittently when switch is placed in the 'J' position. Windshield wipers operate at low or high speed when switch is placed in the 'I' or 'II' position.
4. **Turn Signal/Headlight Dimmer Control.** Operates turn signals and controls headlight dimming. Right turn signal indicator will flash when control is pushed up. Left turn signal indicator will flash when control is pushed down. Headlight dimming is controlled by pulling the control toward the Operator. High beam headlight indicator lights when high beam headlights are on.
5. **Steering Wheel Tilt/Telescope Control.** Adjusts angle and height of steering wheel.

2-5. FLOOR-MOUNTED CONTROLS

Figure 2-11 shows all floor-mounted controls.

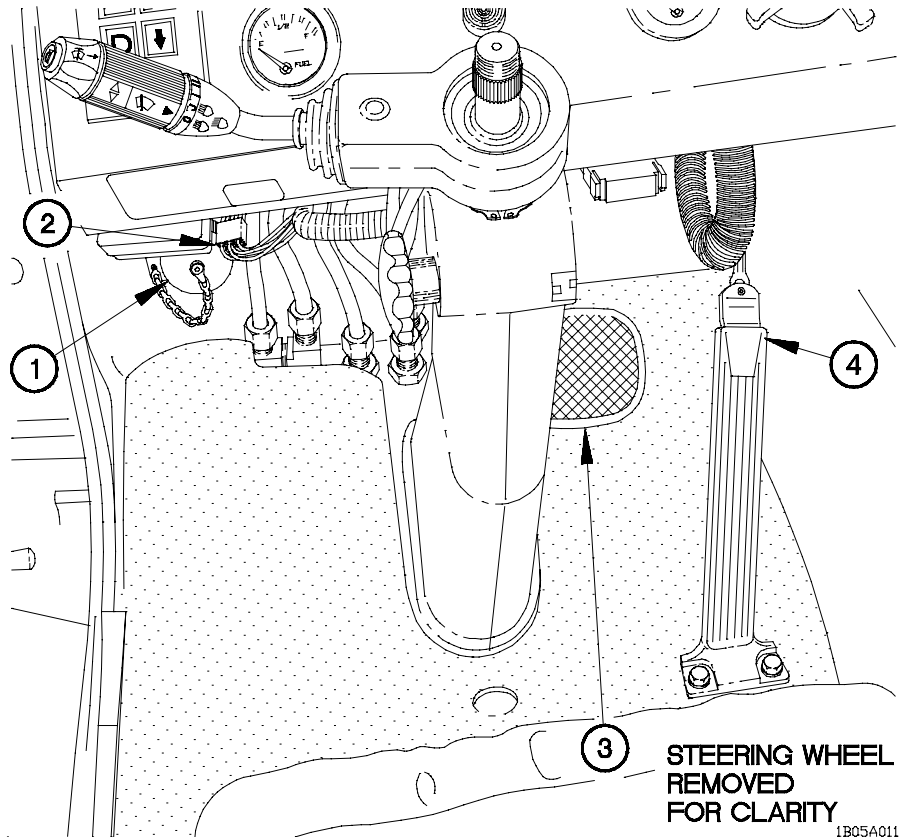


Figure 2-11. Floor-Mounted Controls

1. **STE/ICE-R Receptacle.** Connects Simplified Test Equipment/Internal Combustion Engine-Reprogrammable (STE/ICE-R).
2. **STE/ICE-R Zero Offset Switch.** Resets STE/ICE-R instrument connected to STE/ICE-R receptacle to zero.
3. **Brake Pedal.** Applies service brakes when pressed. Also applies trailer service brakes when the vehicle is coupled to a trailer and TRAILER AIR SUPPLY control is pushed in.
4. **Accelerator Pedal.** Controls engine speed.

2-6. DOOR-MOUNTED CONTROLS

Figure 2-12 shows all door-mounted controls.

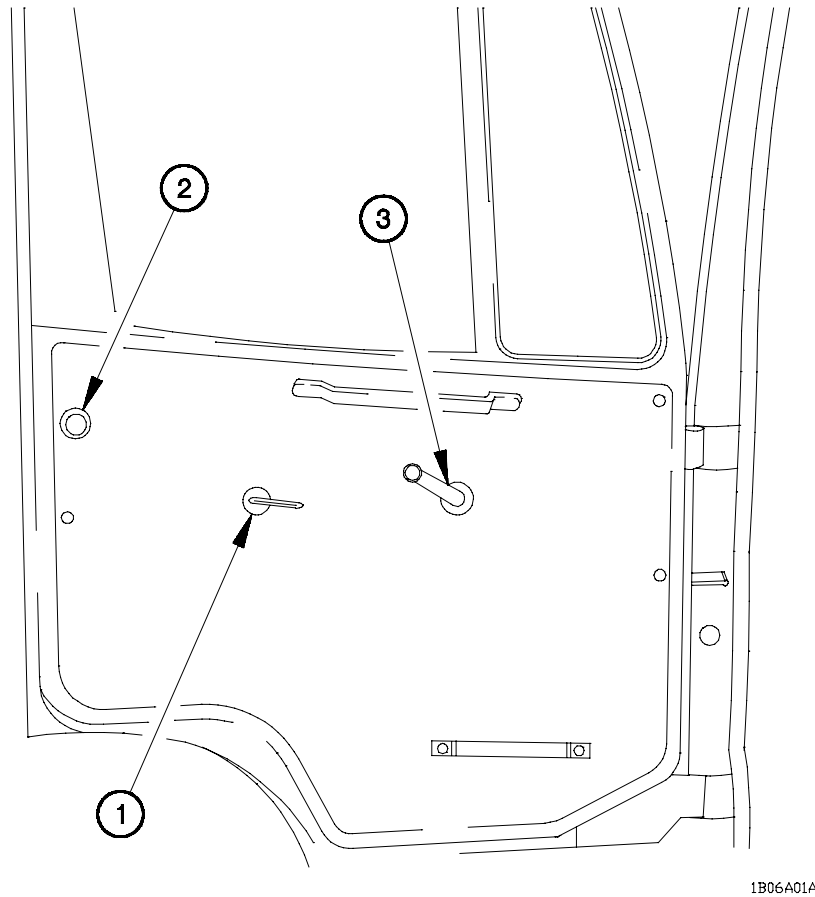


Figure 2-12. Door-Mounted Controls

1. **Cab Door Latch.** Opens cab door from inside or outside of vehicle when pulled.
2. **Cab Door Lock.** Locks door so that it cannot be opened from the inside or outside of the vehicle.
3. **Cab Door Window Glass Regulator.** Raises and lowers window glass when handle is turned.

2-7. SEAT CONTROLS

a. **Driver's Seat Controls.** Figure 2-13 shows all controls on the driver's seat.

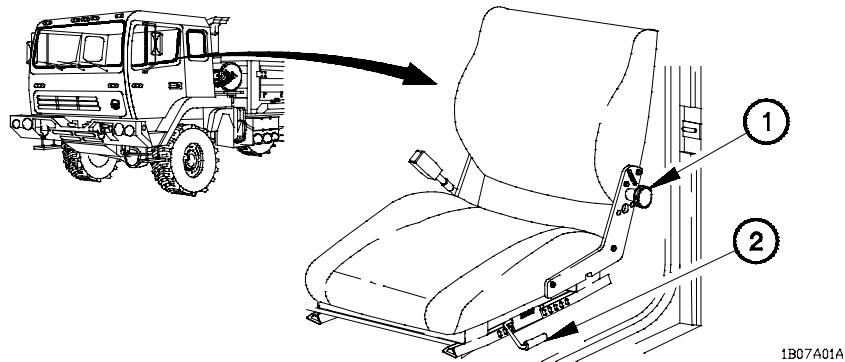


Figure 2-13. Driver's Seat Controls

1. **Seat Back Release Knob.** Allows the seat back to fold forward to allow access to stowage area behind seat.
 - 2. **Forward/Backward Adjustment Control.** Pulling outward (towards door) allows the seat to be moved forward or backward.
- b. **Right Passenger Seat Control.** Figure 2-14 shows the control on the right passenger seat.

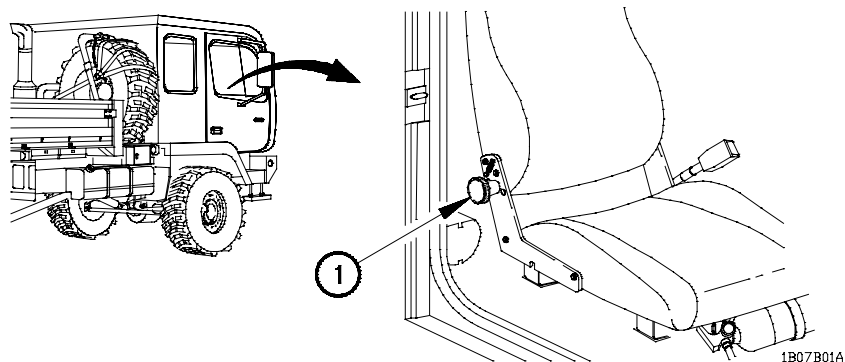


Figure 2-14. Right Passenger Seat Controls

1. **Seat Back Release Knob.** Allows the seat back to fold forward to allow access to stowage area behind seat.

2-8. EXTERIOR CONTROLS AND INDICATORS

a. **Passenger Side Exterior Controls and Indicators.** Figure 2-15 shows all controls on the exterior passenger side of the vehicle.

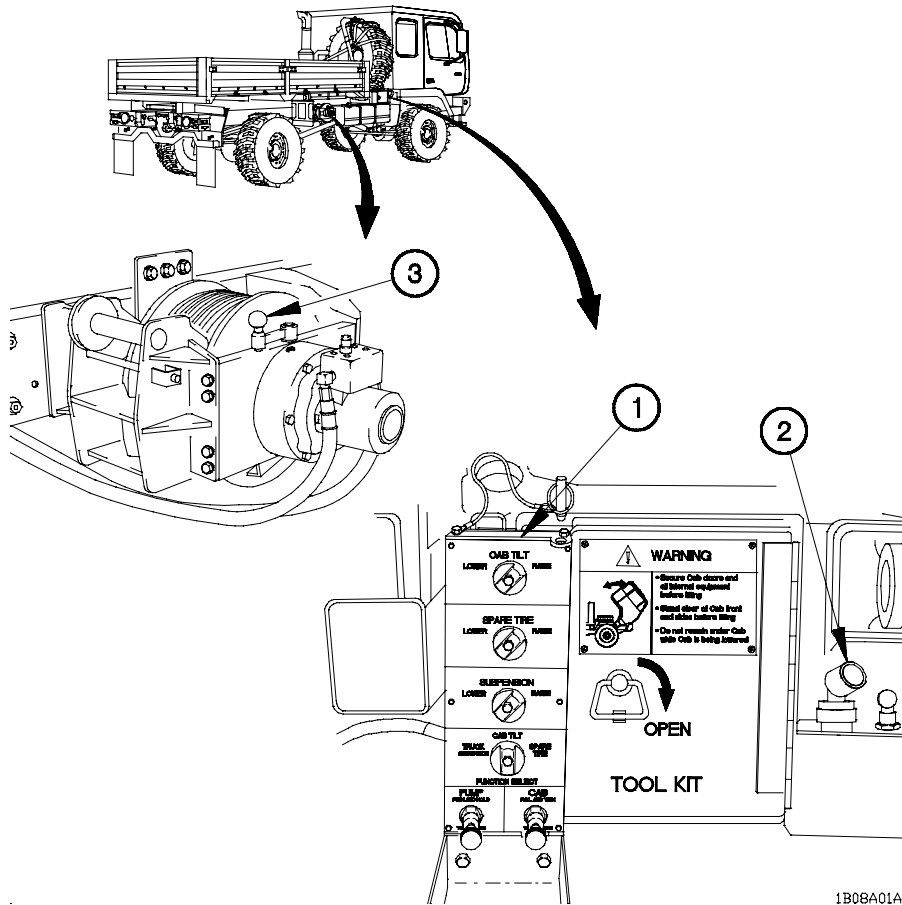
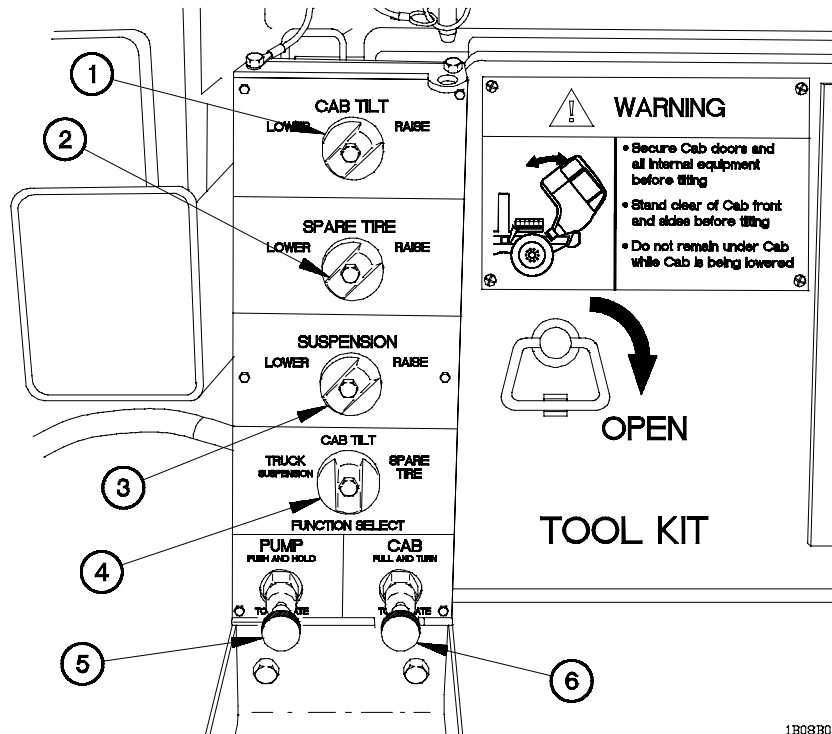


Figure 2-15. Passenger Side Exterior Controls

1. **Hydraulic Manifold.** Used to raise and lower the cab and spare tire, and to compress the suspension for internal air transport. Figure 2-16 shows all controls on hydraulic manifold.
2. **Back-up Pump.** Hydraulic hand pump that provides backup power in case of failure to the hydraulic manifold.
3. **Winch Clutch Control Lever (Models with 11K Self-Recovery Winch [SRW]).** Engages and disengages 11K SRW clutch. When disengaged, winch drum will spool freely and cable can be payed out by hand. When engaged, winch operation is controlled from the WINCH IN/OUT switch inside cab.

2-8. EXTERIOR CONTROLS AND INDICATORS

- b. **Hydraulic Manifold Controls.** Figure 2-16 shows all controls on the hydraulic manifold.



1B08B011

Figure 2-16. Hydraulic Manifold Controls

1. **CAB TILT Knob.** Allows operator to raise or lower cab.
2. **SPARE TIRE Knob.** Allows operator to raise or lower spare tire.
3. **SUSPENSION Knob.** Allows operator to raise or lower suspension.
4. **FUNCTION SELECT Knob.** Allows operator to determine which component will receive hydraulic pressure.
5. **PUMP Knob.** Pushing in and holding PUMP knob will activate selected system; SUSPENSION, CAB TILT, or SPARE TIRE. Works with FUNCTION SELECT Knob.
6. **CAB Knob.** Turn knob to the left and pull out to deflate cab air springs. Press and turn knob to the right to inflate cab air springs.

c. **Driver's Side Exterior Controls and Indicators.** Figure 2-17 shows all controls and indicators on the exterior driver's side of the vehicle.

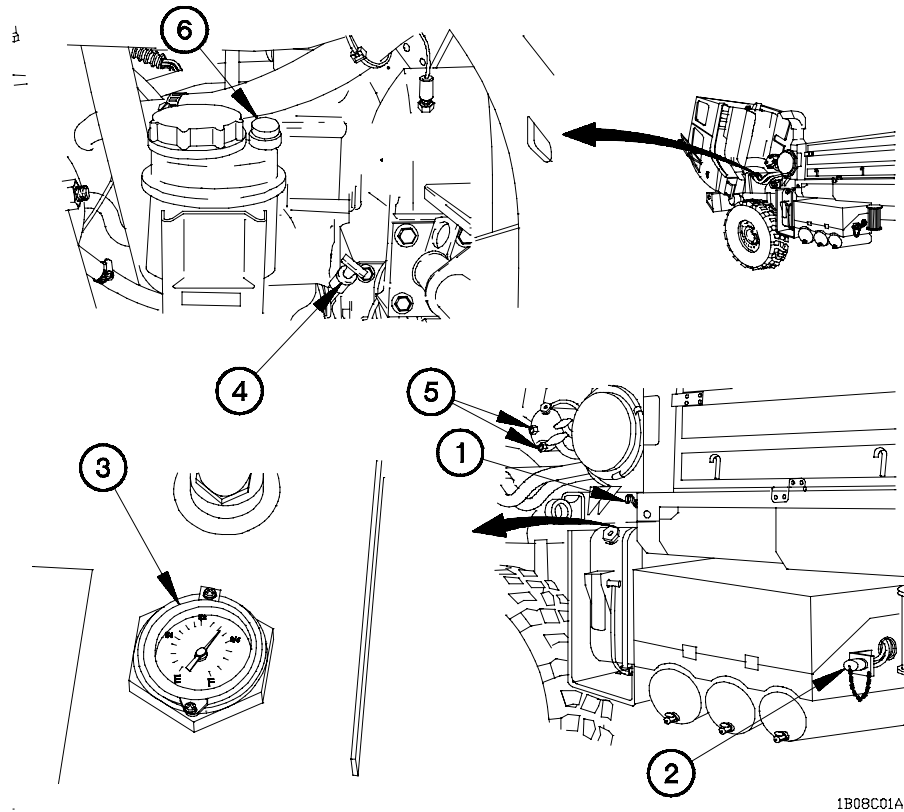
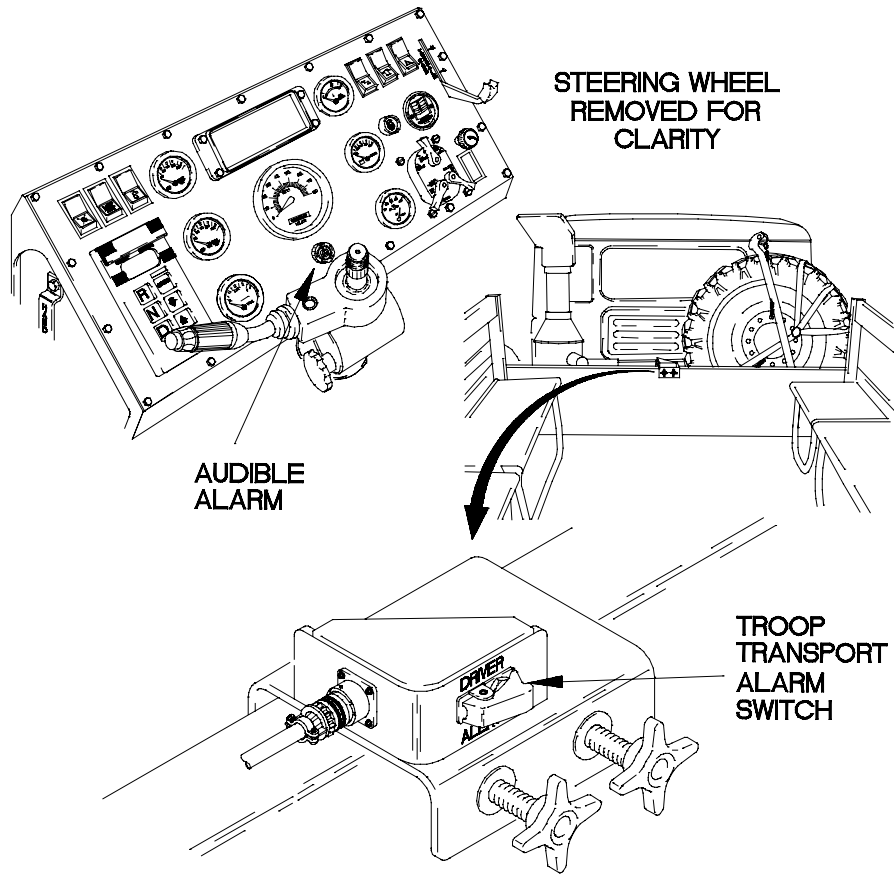


Figure 2-17. Driver's Side Exterior Controls and Indicators

1. **XMSN (Transmission) DIPSTICK.** Indicates oil level in the transmission.
2. **NATO Receptacle.** Receptacle used for starting the vehicle using external power.
3. **Hydraulic Reservoir Gage (Models equipped with 11K Self-Recovery Winch [SRW]).** Indicates oil level in the hydraulic reservoir.
4. **Engine Oil Dipstick.** Indicates oil level in the engine.
5. **Radiator Overflow Tank Sight Glasses.** Top sight glass indicates safe coolant level with the engine not running.
6. **Power Steering Dipstick.** Indicates oil level in the power steering reservoir.

2-9. SPECIAL PURPOSE KIT CONTROLS AND INDICATORS

- a. **Troop Transport Alarm Switch.** Figure 2-18 shows the troop transport alarm switch.

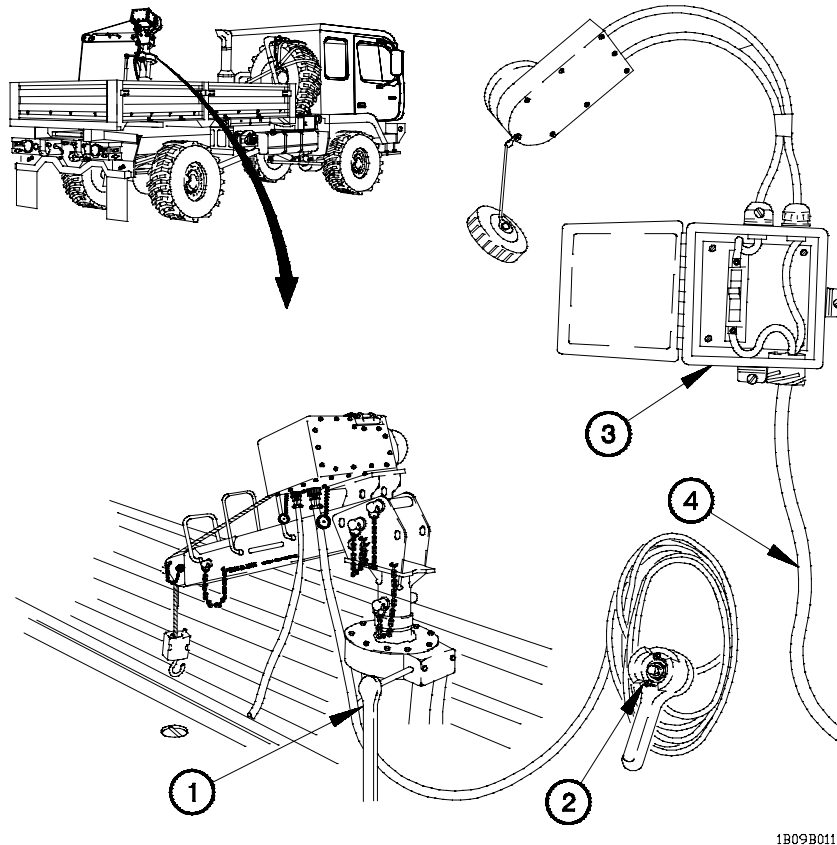


1B09A011

Figure 2-18. Troop Transport Alarm Switch

1. **Troop Transport Alarm Switch.** The troop transport alarm switch is part of the troopseat kit. The troop transport alarm switch is a momentary switch located in the cargo bed when the troopseat kit is installed. The troop transport alarm switch is used to alert the driver to stop the vehicle.
2. **Troop Transport Alarm.** The troop transport alarm is a dual tone audible alarm located in the cab. When activated by the troop transport alarm switch located in the cargo bed, the troop transport alarm alerts the driver to stop the vehicle.

b. LMHC (if equipped). Figure 2-19 shows LMHC controls and indicators.



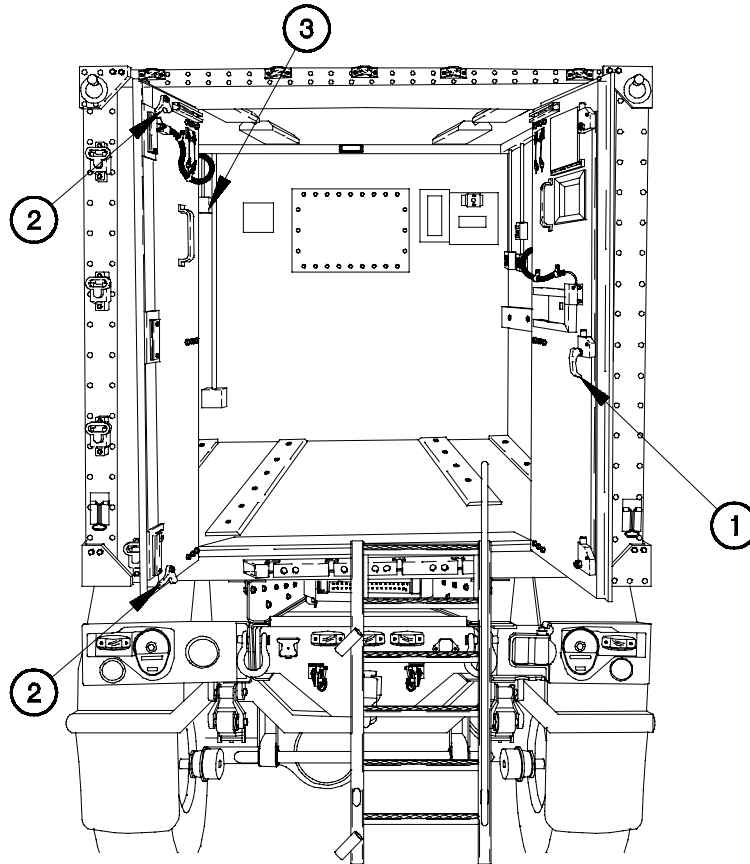
1B09B011

Figure 2-19. Light Material Handling Crane (LMHC) Controls and Indicators

1. **Swing Control.** Swings LMHC boom to right and left.
2. **Remote Hoist Control.** Remote control unit used to extend and retract hoist cable.
3. **Circuit Breaker Box.** Turns power on and off and protects LMHC from damage from overloads or electrical shorts.
4. **Power Cable.** Supplies power to circuit breaker box.

2-10. M1079 VAN CONTROLS

- a. **Interior Controls.** Figure 2-22 shows all van controls and indicators inside the van.

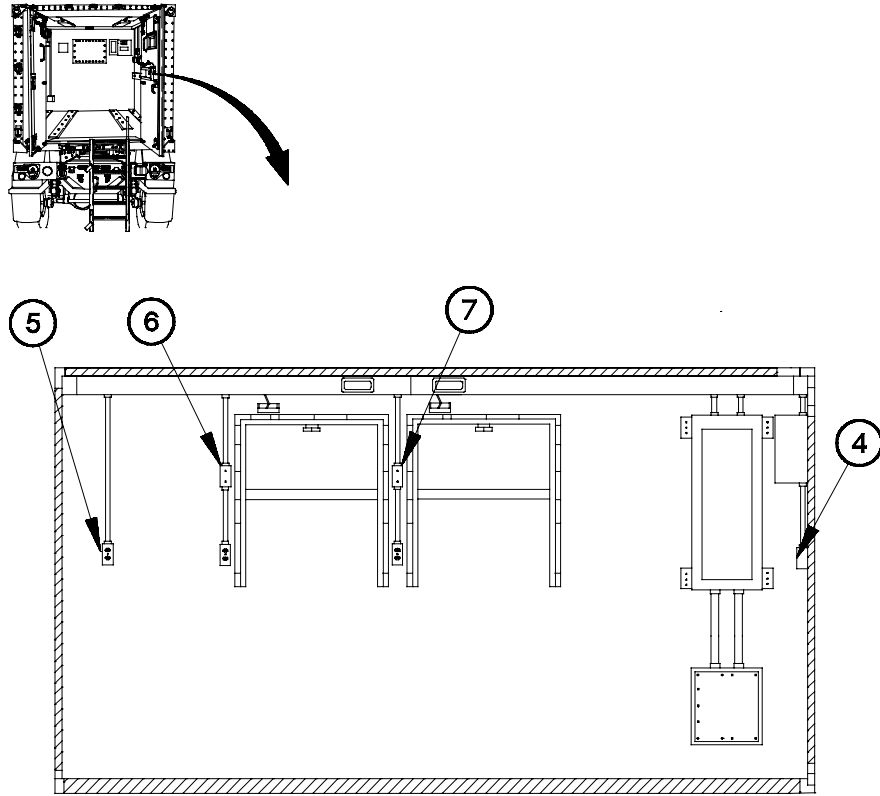


1B10A011

Figure 2-22. Van Interior Controls

1. **RH Door Handle.** Opens RH door when turned and pulled. Located on inside and outside of RH door.
2. **LH Door Latches.** Both upper and lower latches must be turned to open LH door. RH door must be opened first.
3. **FAN Switch.** Controls operation of the ventilation fan.

2-10. M1079 VAN CONTROLS (CONT)

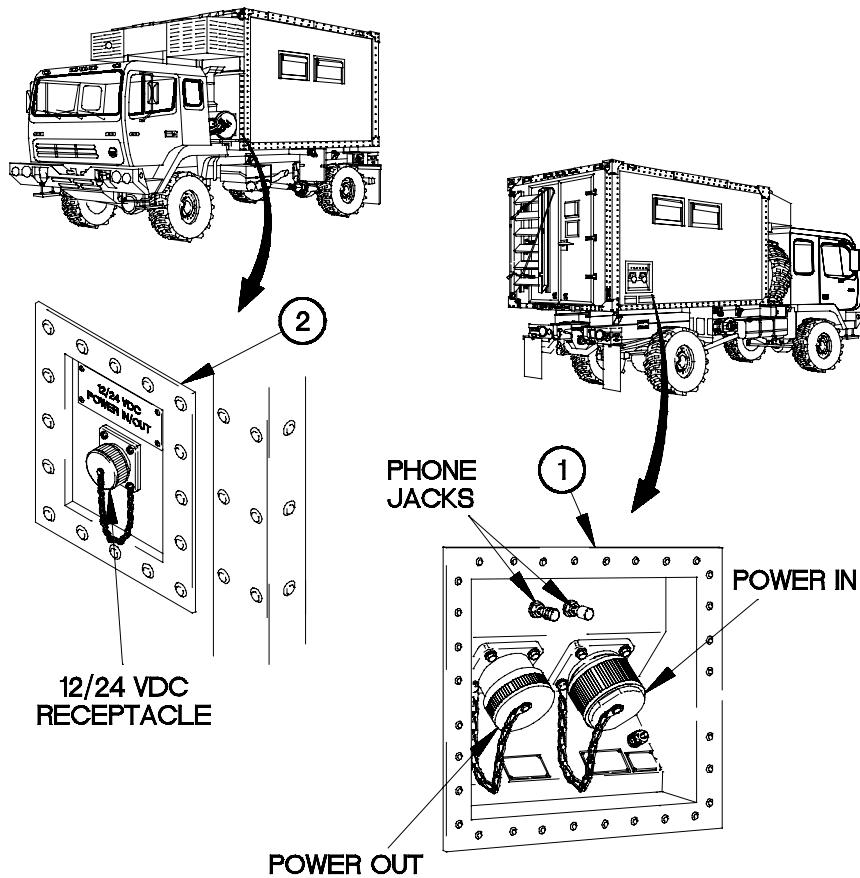


1B10A021

Figure 2-22. Van Interior Controls (Cont)

4. **INTERIOR LIGHTS Switch.** Light switch, located at entrance of van body, that controls operation of lights inside van body.
5. **110 VAC Electrical Outlets.** Six receptacles (three on each side of van body) that supply 110 vac power.
6. **24 VDC Binding Posts.** Two outlets (one on each side of van body) that supply 24 vdc power.
7. **Field Phone Binding Posts.** Two outlets (one on each side of van body) which provide for field phone installation.

b. **Exterior Controls.** Figure 2-23 shows van exterior controls.



1B10B011

Figure 2-23 Van Exterior Controls

1. **110/208 VAC Power Panel.** Two receptacles used to provide van body with 110/208 vac. When an electrical cable is connected from a generator to the POWER IN receptacle, 110/208 vac is supplied to six electrical receptacles inside the van body. Other equipment (independent of van) that requires 110/208 vac can also be powered by connecting to the POWER OUT receptacle. Phone jacks are mounted above power connectors.
2. **12/24 VDC Power Panel.** Provides 24 vdc for outlets and van door switch and 12 vdc for van body marker lights.

Section II. PREVENTIVE MAINTENANCE CHECKS AND SERVICES (PMCS)

2-11. PMCS INTRODUCTION

This section provides information to guide the vehicle Operator/Crew in performing required PMCS functions. Table 2-1. Preventive Maintenance Checks and Services lists and describes PMCS procedures applicable to all models of the vehicle and specifies maintenance intervals to ensure that the vehicle is ready to perform the intended mission. Tables 2-2 and 2-3 list and describe PMCS procedures applicable to specific models of the vehicle and specify maintenance intervals to ensure that the vehicle is ready to perform the intended mission.

2-12. PMCS PROCEDURES

a. General. Tables 2-1 through 2-3. Preventive Maintenance Checks and Services (Operator/Crew PMCS) are provided so you can keep your vehicle in good operating condition and ready for the primary mission.

b. Warnings and Cautions. Always observe the WARNINGS and CAUTIONS appearing in your PMCS table. WARNINGS and CAUTIONS appear before applicable procedures. You must observe these WARNINGS and CAUTIONS to prevent serious injury to yourself and others or prevent your vehicle from being damaged.

c. Explanation of Table Entries.

(1) Item Number Column. Numbers in this column are for reference. When completing DA Form 2404 (Equipment Inspection and Maintenance Worksheet), include the Item Number for the Check/Service indicating a fault. Item Numbers also appear in the order that you must perform Checks and Services for the intervals listed.

(2) Interval Column. This column tells you when you must perform the procedure in the procedure column. BEFORE procedures must be performed before you operate or use the vehicle. DURING procedures must be performed during operation of the vehicle. AFTER procedures must be performed immediately after you have operated the vehicle. Weekly procedures must be performed every seven days. Monthly procedures must be performed approximately every 30 days.

(3) Location Item to Check/Service Column. This column provides the location and the Item(s) to be checked or serviced.

(4) Procedure Column. This column provides the procedure to check or to service the item(s) listed in the check/service column.

(5) Not Fully Mission Capable If: Column. This column tells you what faults will keep your vehicle from being capable of performing the primary mission. If you perform check and service procedures that show faults listed in this column, do not operate the vehicle. Follow standard operating procedures for maintaining the vehicle or reporting equipment failure.

d. Other Table Entries. Be sure to observe all special information and notes that appear in the table.

e. Shortened Intervals. Shorten intervals if operating the equipment under adverse conditions, including longer than usual operating hours. An asterisk will come before the Interval. A footnote will explain the asterisk and the reason for the shortened Interval.

f. Weekly Intervals. When a Check/Service procedure is required for both WEEKLY and BEFORE Intervals, you do not have to perform the procedure twice if the vehicle has been operated during the week.

g. Leakage Criteria. Leakage Criteria is included in the "Not Fully Mission Capable If:" Column.

2-13. GENERAL MAINTENANCE INSTRUCTIONS

WARNING

Adhesives, solvents, and sealing compounds can burn easily, can give off harmful vapors, and are harmful to skin and clothing. Keep away from open fire and use in well-ventilated area. If adhesive, solvent, or sealing compound gets on skin or clothing, wash immediately with soap and water. Failure to comply may result in serious injury or death to personnel.

a. Cleanliness. Dirt, grease, oil, and debris only get in the way and may cover up a serious problem. Use Dry Cleaning Solvent (Item 15, Appendix D) on metal surfaces where directed.

b. Bolts, Nuts, and Screws. Check bolts, nuts, and screws for obvious looseness, and missing, bent, or broken conditions. Look for chipped paint, bare metal, or rust around bolt heads. If any part seems loose, tighten it or notify Unit Maintenance.

c. Welds. Look for loose or chipped paint, rust, or gaps where parts are welded together. If a bad weld is found, notify Unit Maintenance.

d. Electrical Wires and Connections. Look for cracked or broken insulation, bare wires, and loose or broken connectors. Tighten loose connectors and make sure wires are in good shape. If a bad wire or connector is found, notify Unit Maintenance.

2-13. GENERAL MAINTENANCE INSTRUCTIONS (CONT)

e. Hydraulic Lines and Fittings. Look for wear, damage, and leaks; make sure clamps and fittings are tight. Wet spots show leaks. A stain around a fitting or connector can mean a leak. If a leak comes from a loose fitting or connector, tighten it. If something is broken or worn out, notify Unit Maintenance.

f. Damage. Damage is defined as any condition that affects safety or would make the vehicle unserviceable for mission requirements.

2-14. FLUID LEAKAGE

It is necessary to know how fluid leakage affects the status of fuel, oil, coolant, and hydraulic systems. The following are definitions of the different types of leakage that can determine the status of the vehicle. Learn, then be familiar with them, and REMEMBER-WHEN IN DOUBT, NOTIFY UNIT MAINTENANCE!

CAUTION

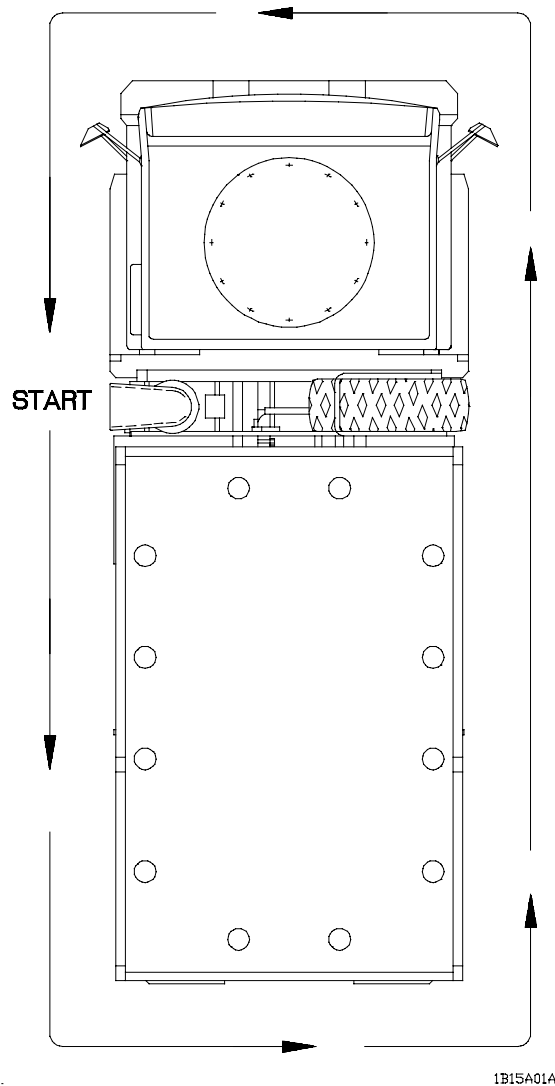
- Equipment operation is allowable with minor leakage (Class I or Class II). Fluid levels of items with Class I and Class II leaks must be checked often so proper levels can be kept. Consideration must be given to the fluid capacity in the item/system being checked/ inspected. Failure to comply may result in damage to equipment.
- Class III leaks must be reported to Unit Maintenance. Failure to comply may result in damage to equipment.

Fluid leakage is classified and defined as follows:

<u>CLASSIFICATION</u>	<u>IDENTIFICATION</u>
Class I	Seepage of fluid (indicated by wetness or discoloration) not great enough to form drops.
Class II	Leakage of fluid great enough to form drops but not enough to cause drops to drip from item being inspected.
Class III	Leakage of fluid great enough to cause drops to drip from item being checked.

**2-15. PREVENTIVE MAINTENANCE CHECKS AND SERVICES
TABLE (ALL MODELS)**

Refer to Table 2-1. Preventive Maintenance Checks and Services (PMCS) for Operator/Crew procedures for all models of the vehicle. The PMCS routing diagram is shown below. It shows the vehicle PMCS routing track which matches the sequence of PMCS given in Table 2-1.



PMCS ROUTING DIAGRAM

Table 2-1. Preventive Maintenance Checks and Services (All Models)

Item No.	Interval	Location	Crewmember Procedure	Not Fully Mission Capable If:
		Item to Check/Service		
NOTE				
Operating vehicle with damaged windshield may violate AR 385-55.				
1	Before	Windshield, Windshield Wipers, and Washer Reservoir	<ul style="list-style-type: none"> a. Check windshield for damage that would impair Operator's vision. b. Check for missing or damaged windshield wiper blade. Notify Unit Maintenance if windshield wiper blade is missing or unserviceable. c. Check windshield washer reservoir fluid level. Add windshield washer fluid as required (Appendix F). 	<ul style="list-style-type: none"> a. Windshield is cracked sufficiently to impair Operator's vision.

Table 2-1. Preventive Maintenance Checks and Services (All Models) (Cont)

Item No.	Interval	Location	Crewmember Procedure	Not Fully Mission Capable If:
		Item to Check/Service		
1.1	Before	Front and Rear Shackles	Check that shackle pins are not loose.	
1.2	Before	Cab Air Springs	Verify cab air springs are unpinned and pin is stowed in stowage bracket.	
2	Before	Exterior of Vehicle	Look under vehicle for signs of fluid leakage (fuel, oil, and coolant).	Class III leak is evident.

Table 2-1. Preventive Maintenance Checks and Services (All Models) (Cont)

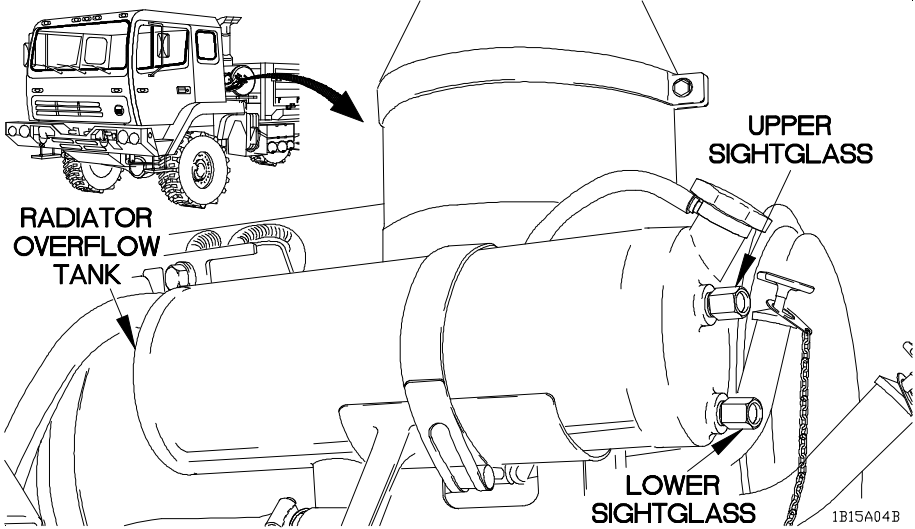
Item No.	Interval	Location	Crewmember Procedure	Not Fully Mission Capable If:
		Item to Check/ Service		
				
<div style="border: 1px solid black; padding: 5px; display: inline-block;">WARNING</div>				
<ul style="list-style-type: none"> • Extreme care should be taken when removing coolant fill cap if temperature gage reads above 180 F (82 C). Contact with steam or hot coolant under pressure may result in injury to personnel. • Pressure in radiator overflow tank must be released before removing cap. Failure to comply may result in injury to personnel. • Do not operate vehicle if radiator cap is damaged or missing. Failure to comply will result in injury or damage to equipment. 				
3	Before	Coolant	<p>a. Check coolant level. Coolant level should be between upper sight-glass and lower sight-glass on radiator overflow tank with engine not running. Add coolant as required (Appendix F, Note 4).</p>	<p>a. Coolant level below lower sightglass.</p>

Table 2-1. Preventive Maintenance Checks and Services (All Models) (Cont)

Item No.	Interval	Location	Crewmember Procedure	Not Fully Mission Capable If:
		Item to Check/ Service		
	Before	Coolant	<ul style="list-style-type: none"> b. Check for engine oil in coolant. c. Check radiator cap. 	<ul style="list-style-type: none"> b. If engine oil is present, Notify Unit Maintenance. c. Radiator cap damaged or missing, notify Unit Maintenance.

Table 2-1. Preventive Maintenance Checks and Services (All Models) (Cont)

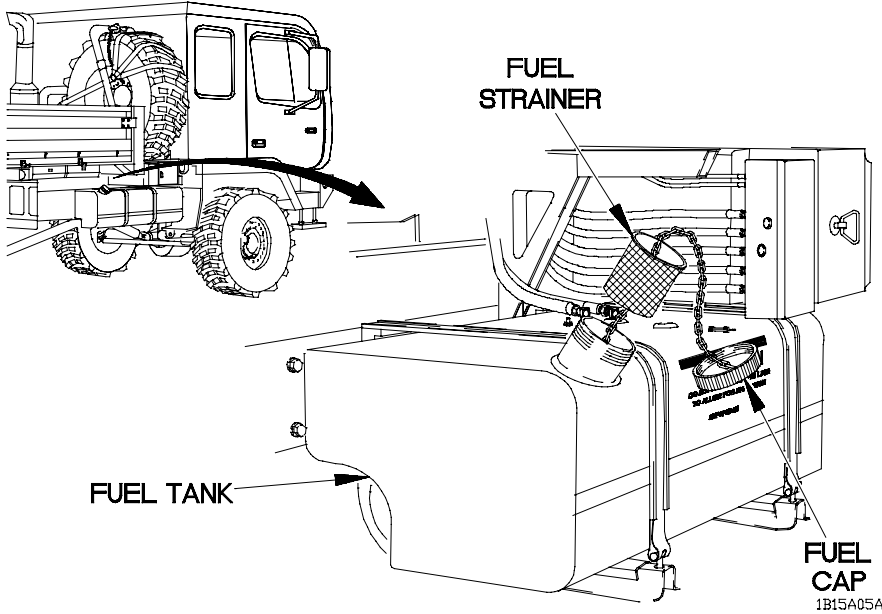
Item No.	Interval	Location	Crewmember Procedure	Not Fully Mission Capable If:
		Item to Check/Service		
 <p style="text-align: center;">WARNING</p> <p>Diesel fuel is flammable. Do not fill fuel tank with engine running, while smoking, or when near an open flame. Never overfill tank or spill fuel. If fuel is spilled, clean it up immediately. Failure to comply may result in serious injury or death to personnel.</p>				
4	Before	Fuel Tank	<ol style="list-style-type: none"> a. Remove fuel cap and fuel strainer. b. Check for presence of fuel in fuel tank. c. Install fuel strainer and fuel cap. 	

Table 2-1. Preventive Maintenance Checks and Services (All Models) (Cont)

Item No.	Interval	Location	Crewmember Procedure	Not Fully Mission Capable If:
		Item to Check/ Service		
5	Before	Spare Tire Strap	<ol style="list-style-type: none"> a. Check that spare tire strap is tight. b. Check that spare tire strap is not torn, frayed, or damaged. c. Check that SPARE TIRE knob is in RAISE position. d. Check that CAB knob (Air Springs) is pushed in. If not, push knob in and turn to the right. 	

1B15A061

Table 2-1. Preventive Maintenance Checks and Services (All Models) (Cont)

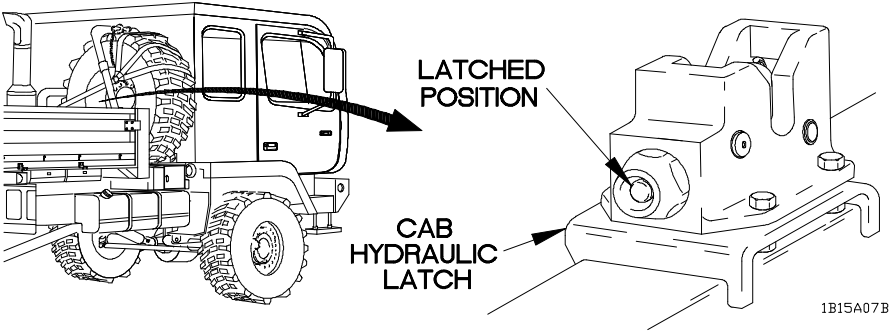
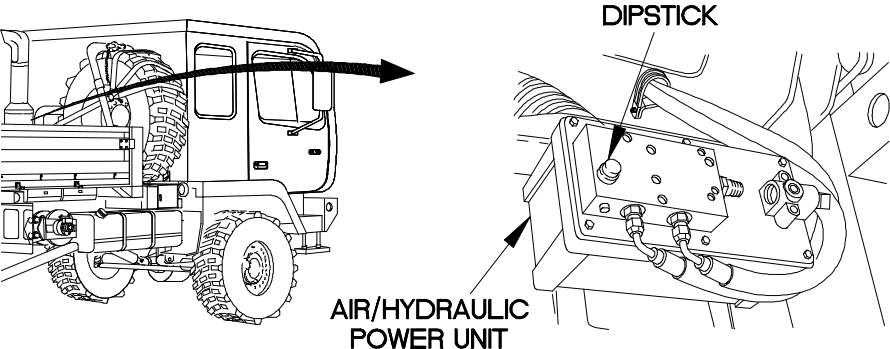
Item No.	Interval	Location	Crewmember Procedure	Not Fully Mission Capable If:
		Item to Check/Service		
6	Before		<p>Check that cab hydraulic latch indicator button is in the latched position.</p>	<p>If cab will not securely latch.</p>
7	Before		<p>Check oil level on dipstick. Add oil as required (Appendix F, Note 6).</p>	

Table 2-1. Preventive Maintenance Checks and Services (All Models) (Cont)

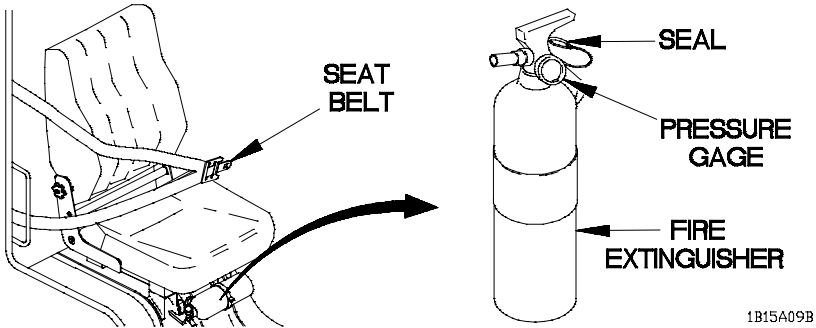
Item No.	Interval	Location	Crewmember Procedure	Not Fully Mission Capable If:
		Item to Check/ Service		
 <p style="text-align: center;">NOTE</p> <ul style="list-style-type: none"> • Operating the vehicle with inoperative seat belts may violate AR 385-55. • If vehicle mission requires three personnel, all three seat belts are required to be in good working condition. 				
8	Before	Seat Belts	Check all three seat belts for security, damage, and proper operation.	Drivers seat belt and at least one other seat belt not in good working condition.
9	Before	Driver's Seat	Check operation of forward/backward adjustment control.	Forward/backward adjustment is broken or missing.
10	Before	Fire Extinguisher	a. Check for missing or damaged fire extinguisher.	a. Fire extinguisher is damaged or missing.

Table 2-1. Preventive Maintenance Checks and Services (All Models) (Cont)

Item No.	Interval	Location	<u>Crewmember Procedure</u>	Not Fully Mission Capable If:
		Item to Check/ Service		
			<p>b. Check that fire extinguisher pressure is approximately 150 psi (1034 kPa).</p>	<p>b. Fire extinguisher pressure gage needle is within discharge band.</p> <p>c. Seal is missing.</p>

Table 2-1. Preventive Maintenance Checks and Services (All Models) (Cont)

Item No.	Interval	Location	Crewmember Procedure	Not Fully Mission Capable If:
		Item to Check/ Service		
<p style="text-align: right; margin-right: 50px;">1B15A101</p>				
<p>NOTE</p> <p>PARK BRAKE and EMERGENCY BRAKE indicators will not illuminate if SYSTEM PARK control is not pulled out. REAR BRAKE AIR and FRONT BRAKE AIR indicators will not illuminate if air system pressure exceeds 65 psi (448 kPa).</p>				
11	Before	Lighted Indicator Display	<p>a. Position master power switch to on.</p> <p>b. Check that the following indicator lights are illuminated:</p> <ol style="list-style-type: none"> 1. STOP 2. PARK BRAKE 3. EMERGENCY BRAKE 4. REAR BRAKE AIR 5. FRONT BRAKE AIR 6. ENGINE OIL PRESSURE 	<p>b. Any of the listed indicator lights is not illuminated.</p>

Table 2-1. Preventive Maintenance Checks and Services (All Models) (Cont)

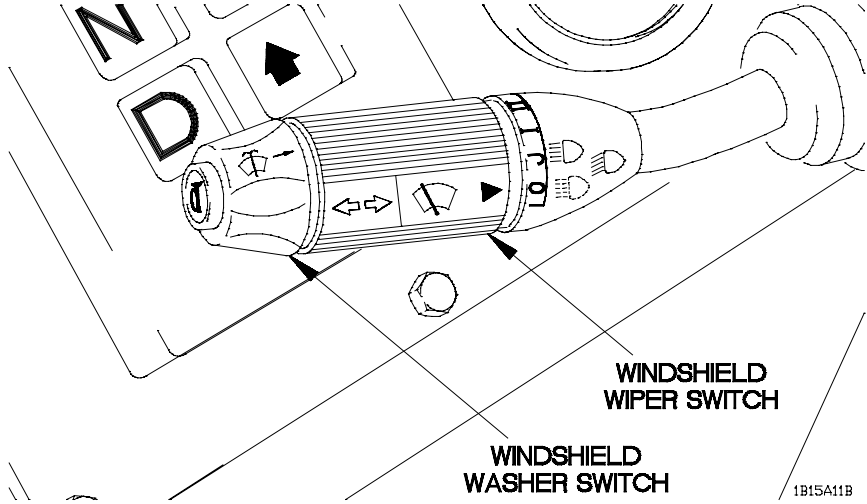
Item No.	Interval	Location	Crewmember Procedure	Not Fully Mission Capable If:
		Item to Check/ Service		
 <p style="text-align: right; margin-right: 50px;">1B15A11B</p>				
11.1	Before	Windshield, Windshield Wipers, and Washer Reservoir (Cont)	<ul style="list-style-type: none"> a. Check windshield washer switch for proper operation. Notify Unit Maintenance if windshield washer switch is inoperative. b. Check windshield wiper switch for proper operation. Notify Unit Maintenance if windshield wiper switch is inoperative. 	

Table 2-1. Preventive Maintenance Checks and Services (All Models) (Cont)

Item No.	Interval	Location	Crewmember Procedure	Not Fully Mission Capable If:
		Item to Check/ Service		
<p style="text-align: right;">1B15A12B</p>				
<p>CAUTION</p> <p>If engine oil pressure indicator does not illuminate momentarily, or illuminates and stays on, vehicle is not fully mission capable. Failure to comply may result in damage to equipment.</p>				
<p>NOTE</p> <p>If OIL PRESS gage reads in red zone (0-7 psi) (0-48 kPa) and engine oil pressure indicator is not illuminated, shut down engine, then restart engine. Indicator should illuminate momentarily to indicate proper function. If engine oil pressure indicator illuminates and then goes out, continue with the mission.</p>				
12	Before	OIL PRESS Gage	a. Start engine (para 2-21a or b).	a. Gage indicates in red zone and engine oil pressure indicator is illuminated.

Table 2-1. Preventive Maintenance Checks and Services (All Models) (Cont)

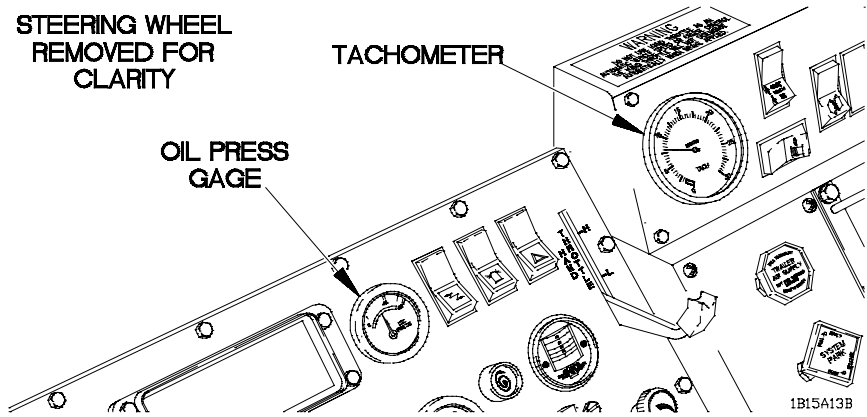
Item No.	Interval	Location	Crewmember Procedure	Not Fully Mission Capable If:
		Item to Check/ Service		
				
NOTE				
<ul style="list-style-type: none"> • Oil pressure will increase when engine speed increases and will decrease when engine speed decreases. • Engine oil pressure will be lower when engine is at maximum operating temperature (WATER TEMP gage reads 230°F (110°C). 				
12	Before	OIL PRESS Gage (Cont)	<p>b. Check that engine OIL PRESS gage indicates between 15-80 psi (103-552 kPa).</p>	<p>b. Gage indicates less than 15 psi (103 kPa).</p>
NOTE				
Perform check (13) only if vehicle is equipped with tachometer.				
13	Before	Tachometer	<p>Check that tachometer indicates between 750-850 rpm while engine is at idle. If tachometer indicates engine rpm outside of 750-850 rpm range, notify Unit Maintenance.</p>	

Table 2-1. Preventive Maintenance Checks and Services (All Models) (Cont)

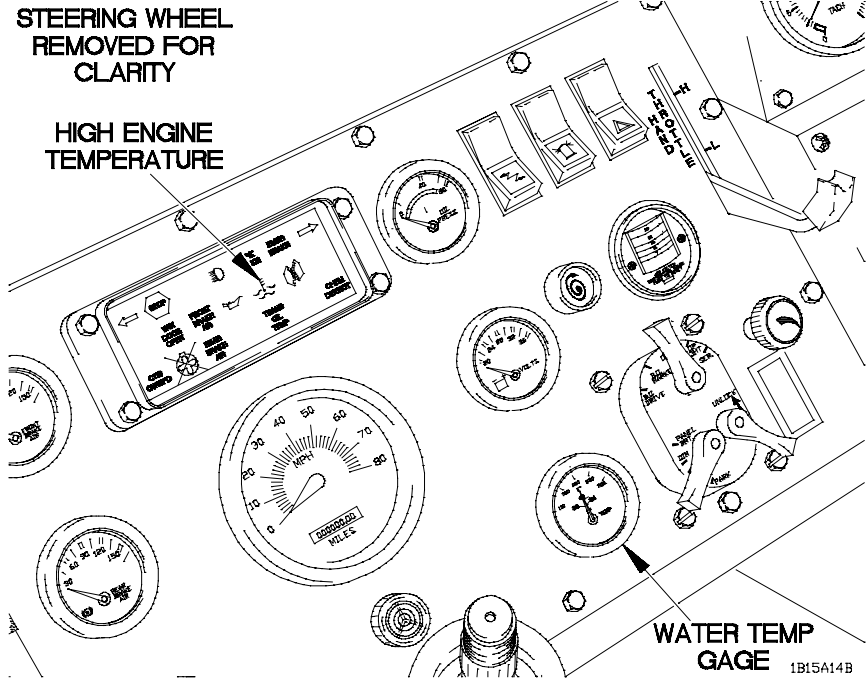
Item No.	Interval	Location	Crewmember Procedure	Not Fully Mission Capable If:
		Item to Check/ Service		
 <p style="text-align: center;">NOTE</p> <ul style="list-style-type: none"> • At idle, WATER TEMP gage may not reach 160°F (71°C). • If high engine temperature indicator is illuminated and WATER TEMP gage reads 160° - 230°F (71° - 110°C) and engine fan is NOT running continuously, continue with the mission. 				
14	Before	WATER TEMP Gage	Check that WATER TEMP gage indicates between 160° - 230°F (71° - 110°C).	WATER TEMP gage indicates in red zone and high engine temperature indicator is illuminated.

Table 2-1. Preventive Maintenance Checks and Services (All Models) (Cont)

Item No.	Interval	Location	Crewmember Procedure	Not Fully Mission Capable If:
		Item to Check/ Service		
<p style="text-align: right;">1B15A15B</p>				
15	Before	AIR FILTER RESTRICTION GAUGE	<p>Check AIR FILTER RESTRICTION GAUGE. Press reset button if gauge reads greater than 25 in. (in red area). If gauge still reads in red area after reset button is pressed, shut down engine and service air filter (para 3-9). Start engine (para 2-21a or b). Notify Unit Maintenance if gauge still reads in red area.</p>	<p>AIR FILTER RESTRICTION GAUGE reads greater than 25 in. (in red area).</p>

Table 2-1. Preventive Maintenance Checks and Services (All Models) (Cont)

Item No.	Interval	Location	Crewmember Procedure	Not Fully Mission Capable If:
		Item to Check/ Service		
16	Before	FRONT BRAKE AIR and REAR BRAKE AIR Gages	Check that FRONT BRAKE AIR and REAR BRAKE AIR gages read between 65-120 psi (448-827 kPa).	Either gage indicates less than 65 psi (448 kPa), FRONT BRAKE AIR or REAR BRAKE AIR indicators illuminate, or audible alarm sounds.
17	Before	VOLTS Gage	Check that VOLTS gage reads between 26 and 30 volts.	VOLTS gage indicates more than 30 volts or less than 26 volts.

Table 2-1. Preventive Maintenance Checks and Services (All Models) (Cont)

Item No.	Interval	Location	Crewmember Procedure	Not Fully Mission Capable If:
		Item to Check/ Service		
18	Before	FUEL Gage	<p>Check FUEL gage for proper operation. Compare FUEL gage reading with observed level of fuel in fuel tank (from item 4).</p>	
<div style="border: 1px solid black; padding: 5px; display: inline-block;">CAUTION</div>				
<p>Check SYSTEM PARK control while vehicle is stopped. Failure to comply may result in damage to equipment.</p>				
19	Before	SYSTEM PARK Control	<p>a. Pull out SYSTEM PARK control.</p> <p>b. Set WTEC II TEPSS or WTEC III TPSS to any forward gear (para 2-21e) while engine is at idle (approximately 750 rpm). Vehicle should not move.</p>	<p>b. Vehicle moves with SYSTEM PARK control on.</p>

Table 2-1. Preventive Maintenance Checks and Services (All Models) (Cont)

Item No.	Interval	Location	Crewmember Procedure	Not Fully Mission Capable If:
		Item to Check/ Service		
20	Before	WTEC II TEPSS or WTEC III TPSS	Check that WTEC II TEPSS or WTEC III TPSS operates properly in all gears (para 2-21e).	One gear range does not operate properly or LED display indicates service message which cannot be reset.
21	Before	Turn Signal Control	Check turn signal control and indicators for proper operation.	

Table 2-1. Preventive Maintenance Checks and Services (All Models) (Cont)

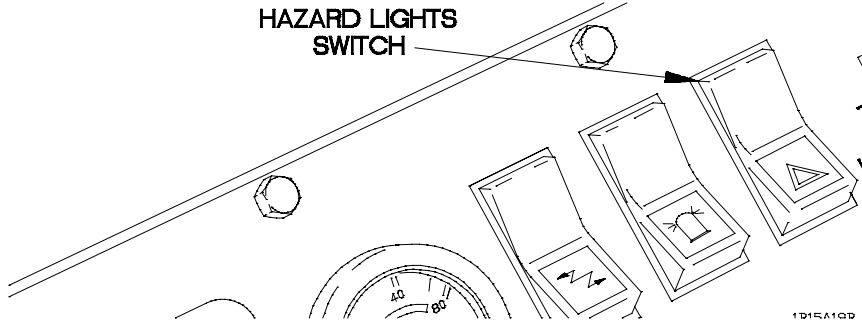
Item No.	Interval	Location	Crewmember Procedure	Not Fully Mission Capable If:
		Item to Check/ Service		
 <p style="text-align: center;">NOTE</p> <p>Checking condition of hazard lights switch is a safety task that would not be performed in a tactical mission. See AR 385-55.</p>				
22	Before	Hazard Lights Switch	Check hazard lights switch for proper operation.	
<div style="border: 1px solid black; padding: 5px; width: fit-content; margin: 0 auto;">CAUTION</div> <p>All gages must maintain normal readings as listed in BEFORE checks during vehicle operation. Operating the vehicle for an extended period of time with any of the gages reading outside of normal limits may result in damage to equipment.</p>				
23	During	Controls and Indicators	Monitor all gages, warning lights, and warning buzzers during operation.	Warning lights or buzzers indicate a malfunction and immediate corrective action by the Operator will not correct the problem.

Table 2-1. Preventive Maintenance Checks and Services (All Models) (Cont)

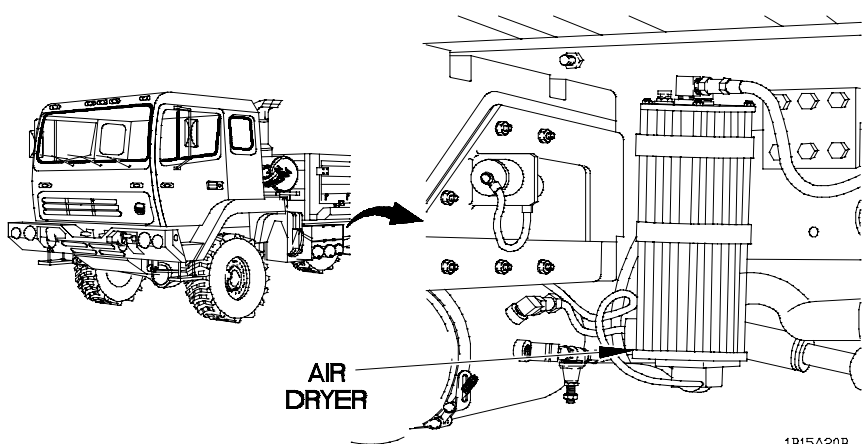
Item No.	Interval	Location	Crewmember Procedure	Not Fully Mission Capable If:
		Item to Check/ Service		
24	During	Engine Operation	Check for excessive exhaust smoke, unusual engine noise, rough running, or misfiring engine.	Any of these conditions are found.
25	During	CTIS	Check operation of CTIS (para 2-23).	
				
<p>NOTE</p> <p>Sound of air dryer discharging is normal.</p>				
26	During	Air Dryer	Listen for air dryer discharge when system air pressure reaches approximately 120 psi (827 kPa).	Steering binds or is unresponsive.
27	During	Steering	Check for any unusual steering noise, binding, or difficulty in turning during operation.	

Table 2-1. Preventive Maintenance Checks and Services (All Models) (Cont)

Item No.	Interval	Location	Crewmember Procedure	Not Fully Mission Capable If:
		Item to Check/Service		
28	During	Service Brakes	<p>a. Check to see if service brakes stop vehicle.</p> <p>b. Check if service brakes pull vehicle to one side when applied.</p> <p>c. Listen for unusual noises (chattering, grinding, groaning, or excessive squealing) during braking. Notify Unit Maintenance if unusual noises are present.</p>	<p>a. Service brakes do not stop vehicle.</p> <p>b. Vehicle pulls to one side when service brakes are applied.</p>
29	After	Hydraulic Manifold	Inspect hydraulic manifold for leakage.	Class III leak is evident.

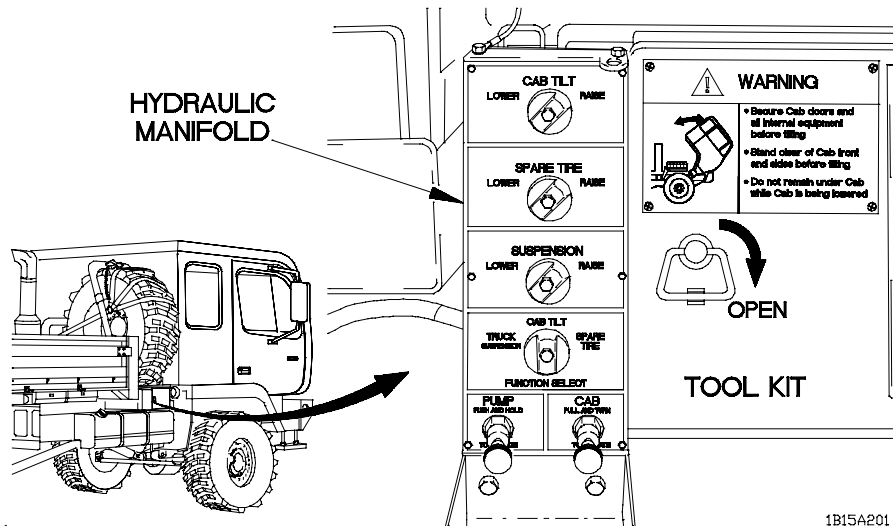


Table 2-1. Preventive Maintenance Checks and Services (All Models) (Cont)

Item No.	Interval	Location	Crewmember Procedure	Not Fully Mission Capable If:
		Item to Check/Service		
30	After	Cab Hydraulic Cylinder	<ul style="list-style-type: none"> a. Raise cab (para 2-22a). b. Check cab hydraulic cylinder for oil leaks or damage. c. Check linkage for damage and missing hardware. 	<ul style="list-style-type: none"> b. Class III leak is evident or cab will not raise or lower. c. Linkage is damaged or missing hardware.
31	After	Cab Hydraulic Latch	Check cab hydraulic latch for damage and hoses for oil leaks.	Class III leak is evident and cab will not latch.

Table 2-1. Preventive Maintenance Checks and Services (All Models) (Cont)

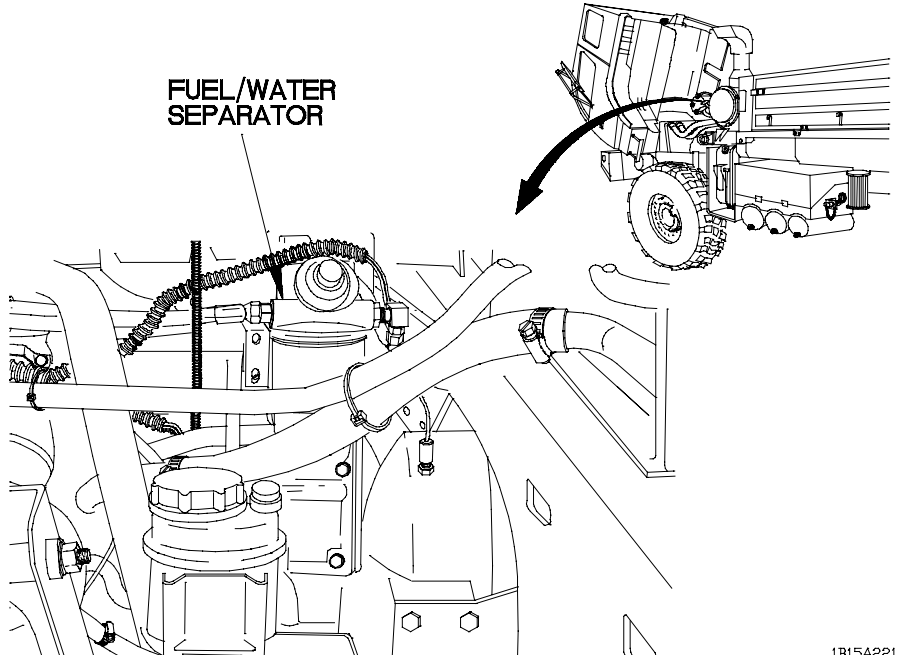
Item No.	Interval	Location	Crewmember Procedure	Not Fully Mission Capable If:
		Item to Check/Service		
				
<div style="border: 1px solid black; padding: 5px; width: fit-content; margin: 0 auto;"> WARNING </div> <p>Do not perform fuel/water separator checks, inspections, or draining while smoking, or when near fire or sparks. Fuel could ignite. Failure to comply may result in serious injury or death to personnel.</p>				
<p>NOTE</p> <p>Operating vehicle with damaged fuel/water separator may violate AR 385-55.</p>				
32	After	Fuel/Water Separator	a. Check fuel/water separator for leaks or damage.	a. Class III leak is evident.

Table 2-1. Preventive Maintenance Checks and Services (All Models) (Cont)

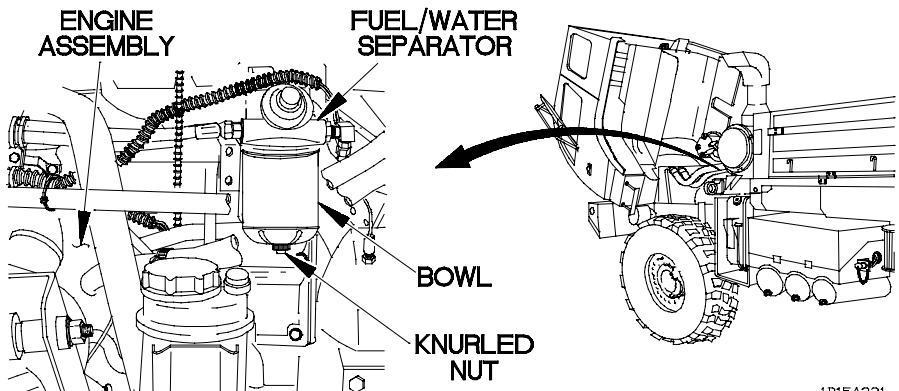
Item No.	Interval	Location	Crewmember Procedure	Not Fully Mission Capable If:
		Item to Check/ Service		
 <p style="text-align: right; margin-right: 50px;">1B15A231</p> <p style="text-align: center;">NOTE Drain fuel into container.</p>				
32	After	Fuel/Water Separator (Cont)	<p>b. Check for presence of water in bowl of fuel/water separator. If there is water in bowl, perform the following steps:</p> <ol style="list-style-type: none"> (1) Turn knurled nut to the left to open drain valve. (2) Keep draining until only pure fuel is coming out. (3) Close drain valve by turning knurled nut to the right. 	
33	After	Engine Compartment	Visually inspect engine compartment for obvious damage that would impair operation.	Class III leak is evident.

Table 2-1. Preventive Maintenance Checks and Services (All Models) (Cont)

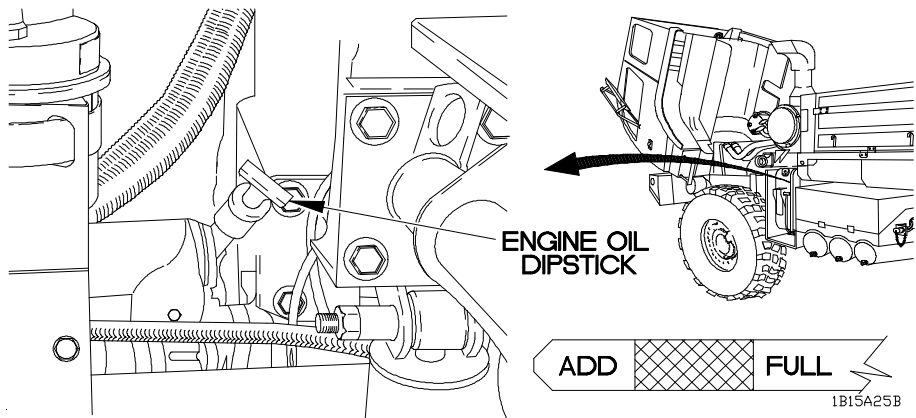
Item No.	Interval	Location	Crewmember Procedure	Not Fully Mission Capable If:
		Item to Check/ Service		
				
34	After	Engine Oil	<ol style="list-style-type: none"> a. Check engine oil dipstick for oil level. Level should be between ADD line and FULL line. b. Add oil as required (Appendix F, Note 1). c. Lower cab (para 2-22b). 	If engine oil is over FULL LINE, discolored, or milky, Notify Unit Maintenance.

Table 2-1. Preventive Maintenance Checks and Services (All Models) (Cont)

Item No.	Interval	Location	Crewmember Procedure	Not Fully Mission Capable If:
		Item to Check/Service		
		<p style="text-align: center;">NOTE</p> <p style="text-align: center;">Perform transmission oil check when engine is at normal operating temperature (160 F - 230 F (71 C - 110 C)).</p>		
35	After	Transmission Oil	<ol style="list-style-type: none"> a. Start engine (para 2-21a or b). b. Check TRANSMISSION OIL DIPSTICK for transmission oil level. Level should be between HOT ADD line and HOT FULL line. c. Add oil as required (Appendix F, Note 2). d. Shut down engine (para 2-21f). 	If transmission oil is over HOT FULL line, discolored, or milky, Notify Unit Maintenance.

Table 2-1. Preventive Maintenance Checks and Services (All Models) (Cont)

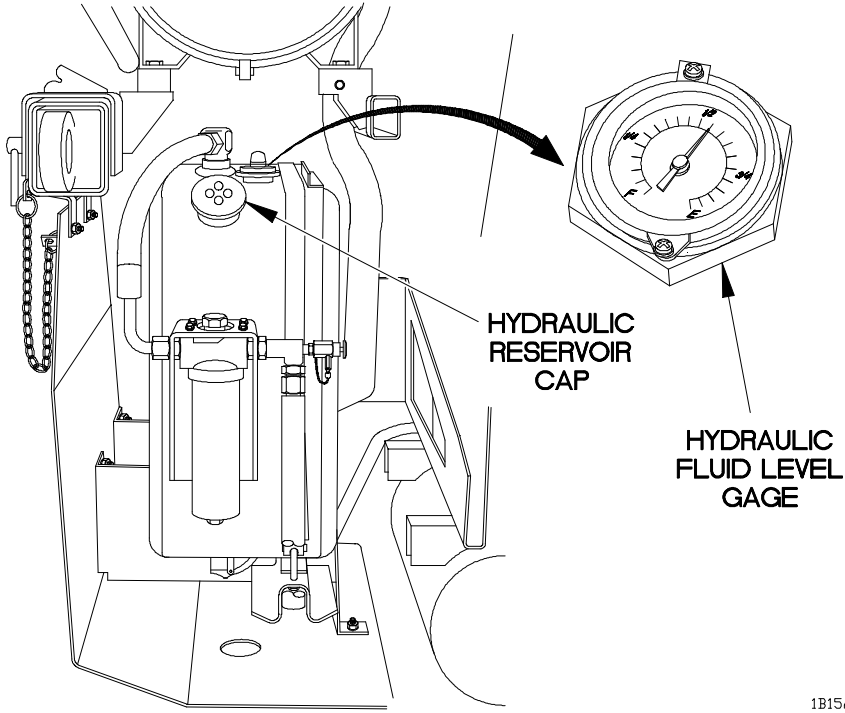
Item No.	Interval	Location	Crewmember Procedure	Not Fully Mission Capable If:
		Item to Check/ Service		
 <p style="text-align: right;">1B15A27B</p> <p style="text-align: center;">NOTE</p> <p style="text-align: center;">During a cold check, oil level gage should read two marks past 3/4 mark.</p>				
36	After	Hydraulic Reservoir (If Equipped)	a. Check hydraulic fluid level (Appendix F, Note 3).	

Table 2-1. Preventive Maintenance Checks and Services (All Models) (Cont)

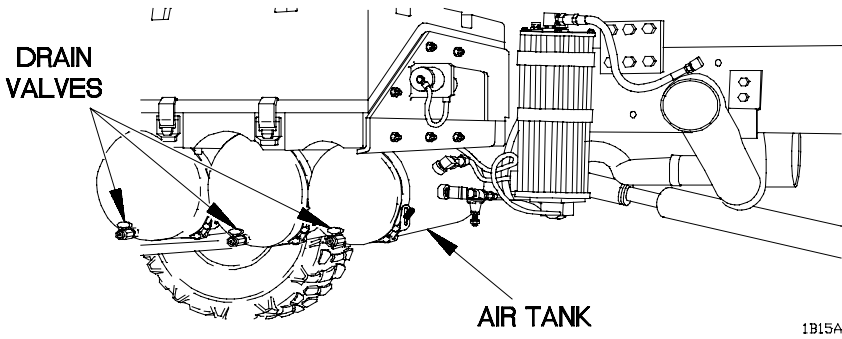
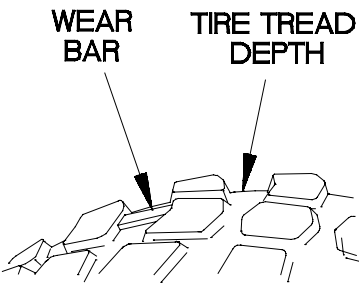
Item No.	Interval	Location	Crewmember Procedure	Not Fully Mission Capable If:
		Item to Check/Service		
 <p style="text-align: right; margin-right: 50px;">1B15A271</p>				
37	After	Air Tanks	<p>a. With vehicle parked and engine shut down, listen for sound of air leaks around air tanks.</p> <p>b. Open air tank drain valves and drain moisture.</p>	a. Air leak(s) heard around air tanks.
 <p style="text-align: center; margin-top: 10px;">1B15A281</p>				
38	After	Tires	<p>Check for missing or improperly inflated tires. Check tires for cuts, gouges, cracks, and unusual bulges. Remove any object that could penetrate tire(s).</p>	Tire missing, deflated, or worn to wear bar.

Table 2-1. Preventive Maintenance Checks and Services (All Models) (Cont)

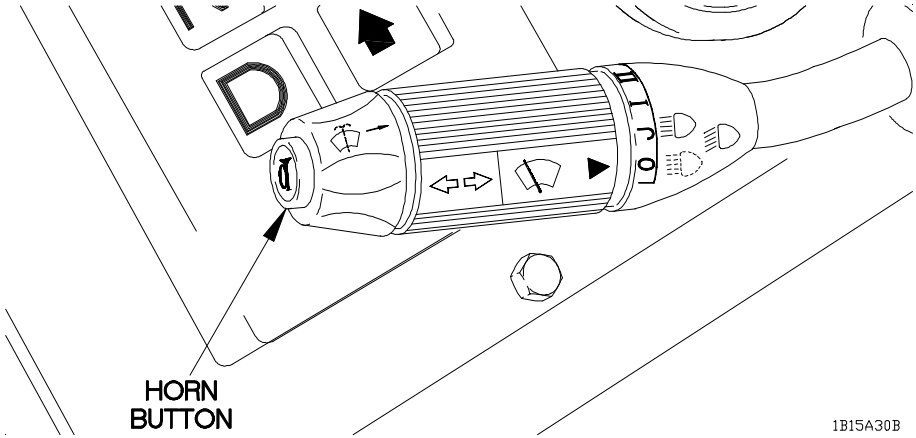
Item No.	Interval	Location	<u>Crewmember Procedure</u>	Not Fully Mission Capable If:
		Item to Check/Service		
				
<p>NOTE</p> <p>Checking condition of horn is a safety task that would not be performed in a tactical mission. See AR 385-55.</p>				
39	After	Horn Button	Check horn button for proper operation.	
<p>NOTE</p> <ul style="list-style-type: none"> • Operating vehicle with damaged or inoperable headlights may violate AR 385-55. • Checking lights is a safety task that would not be performed in a tactical mission. See AR 385-55. 				
40	After	Lights	Check headlights, turn signals, taillights, stoplights, marker lights, blackout drive, and blackout marker lights for damage and proper operation (para 2-21c).	

Table 2-1. Preventive Maintenance Checks and Services (All Models) (Cont)

Item No.	Interval	Location	Crewmember Procedure	Not Fully Mission Capable If:
		Item to Check/Service		
<div style="border: 1px solid black; padding: 5px; display: inline-block; margin-bottom: 10px;">CAUTION</div> <p>Ensure all switches are placed in the OFF position. Batteries could discharge. Failure to comply may result in damage to equipment.</p>				
41	After	Light Switches	Place all light switches in the off position (para 2-21c).	
41.1	Weekly	Front Gladhands	<ol style="list-style-type: none"> a. Check front gladhands for damage and air leaks. b. Remove dummy couplings and check for obstructions. c. Inspect and lubricate coupler seals (Appendix F, Note 8) 	<ol style="list-style-type: none"> a. Air leaks are heard. b. Gladhands are obstructed. c. Coupler seals are faulty.

1B15A32B

Table 2-1. Preventive Maintenance Checks and Services (All Models) (Cont)

Item No.	Interval	Location	Crewmember Procedure	Not Fully Mission Capable If:
		Item to Check/ Service		
42	Weekly	Mounting/ Coupling Hardware and Hoses/ Tubes	<p>a. Check bolts, nuts, clamps, hoses, and tubes for looseness and missing, broken, or leaking conditions. Tighten loose bolts, nuts, and clamps. If bolts, nuts, clamps, hoses, or tubes are missing, broken, cannot be tightened, or damaged to the point of leaking, notify Unit Maintenance. The following should be checked:</p>	

Table 2-1. Preventive Maintenance Checks and Services (All Models) (Cont)

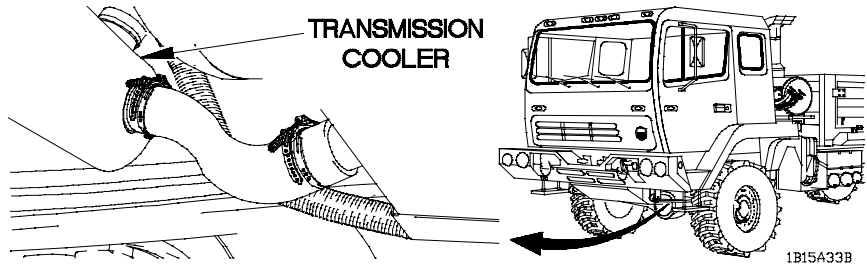
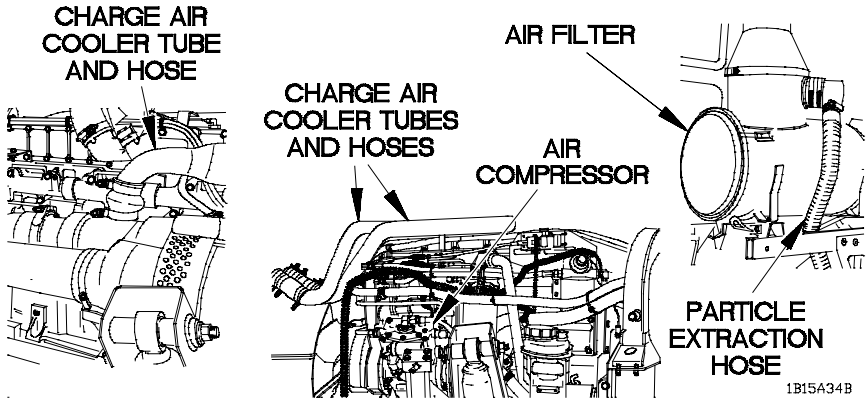
Item No.	Interval	Location	Crewmember Procedure	Not Fully Mission Capable If:	
		Item to Check/Service			
42	Weekly				b. Transmission cooling system.
		Mounting/ Coupling Hardware and Hoses/ Tubes (Cont)			
					c. Air intake system, including air filter, particle extraction hose, charge air cooler tubes/hoses, and air compressor.

Table 2-1. Preventive Maintenance Checks and Services (All Models) (Cont)

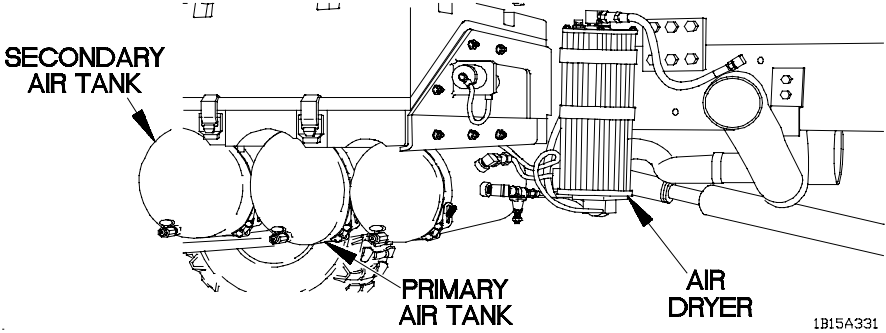
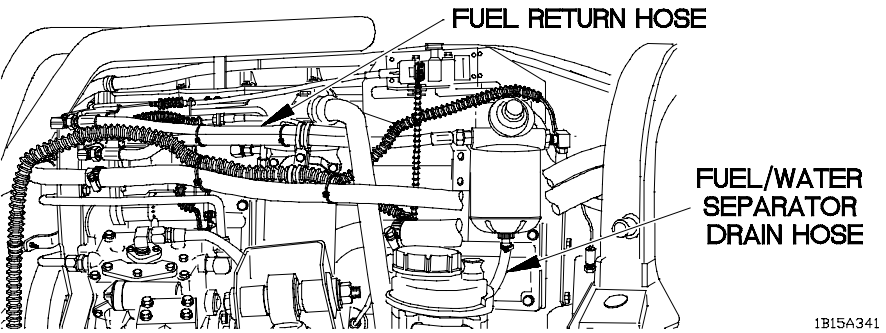
Item No.	Interval	Location	Crewmember Procedure	Not Fully Mission Capable If:
		Item to Check/Service		
 <p>Diagram illustrating the air system components: SECONDARY AIR TANK, PRIMARY AIR TANK, and AIR DRYER. Reference number: 1B15A331.</p>				
42	Weekly	Mounting/ Coupling Hardware and Hoses/ Tubes (Cont)	d. Air system, including air dryer and air tanks.	
 <p>Diagram illustrating the fuel system components: FUEL RETURN HOSE and FUEL/WATER SEPARATOR DRAIN HOSE. Reference number: 1B15A341.</p>				
			e. Fuel system, including fuel return hose and fuel/water separator drain hose.	

Table 2-1. Preventive Maintenance Checks and Services (All Models) (Cont)

Item No.	Interval	Location	Crewmember Procedure	Not Fully Mission Capable If:
		Item to Check/Service		
43	Weekly	Mounting/ Coupling Hardware and Hoses/ Tubes	<p>Check nuts, bolts, clamps, hoses, and tubes for looseness and missing, broken, or leaking conditions. If damage is found, notify Unit Maintenance. The following should be checked:</p> <p>a. Suspension, including springs and U-bolts.</p>	

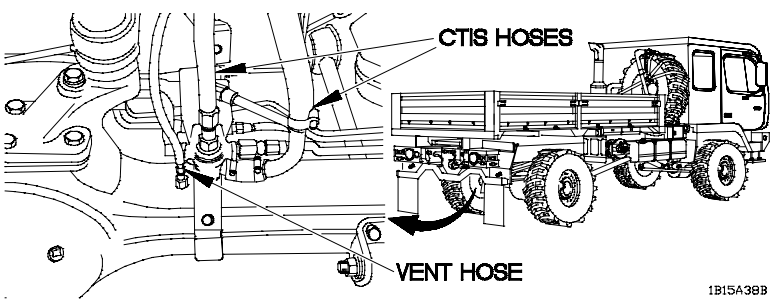
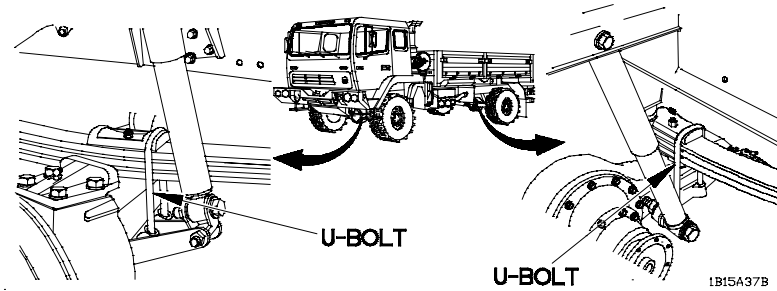


Table 2-1. Preventive Maintenance Checks and Services (All Models) (Cont)

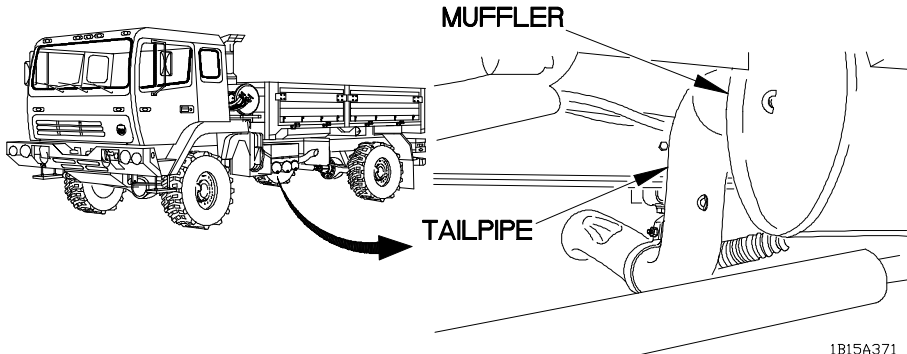
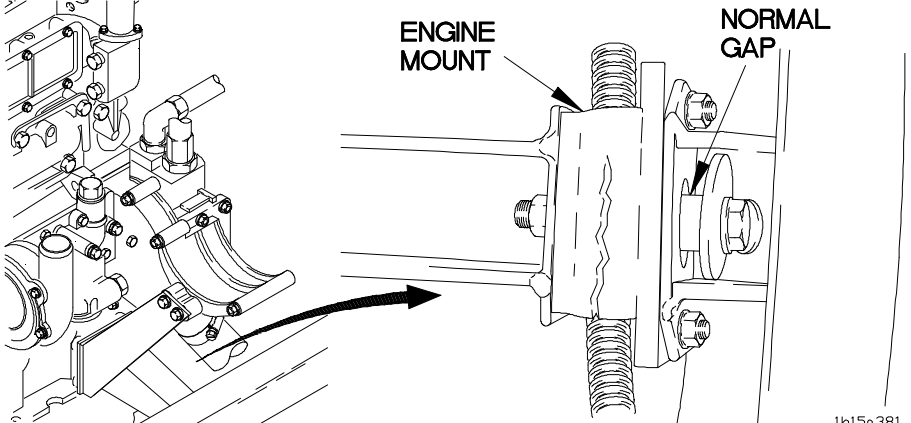
Item No.	Interval	Location	Crewmember Procedure	Not Fully Mission Capable If:
		Item to Check/Service		
43	Weekly	Mounting/ Coupling Hardware and Hoses/ Tubes (Cont)		c. Exhaust system, including muffler and tailpipe.
				

Table 2-1. Preventive Maintenance Checks and Services (All Models) (Cont)

Item No.	Interval	Location	Crewmember Procedure	Not Fully Mission Capable If:
		Item to Check/Service		
43	Weekly	Mounting/Coupling Hardware and Hoses/Tubes (Cont)	e. Engine/transmission supports (cradle mounts).	
			f. Drive shaft bearing cup screws.	

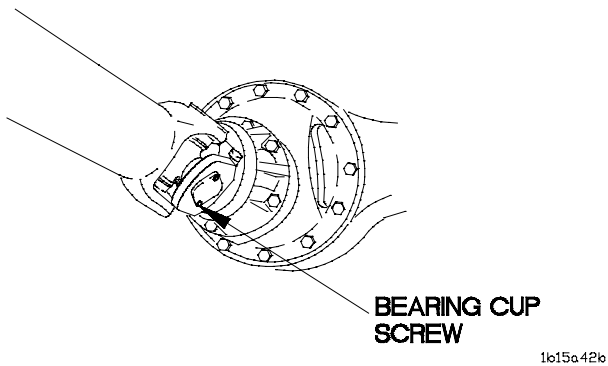
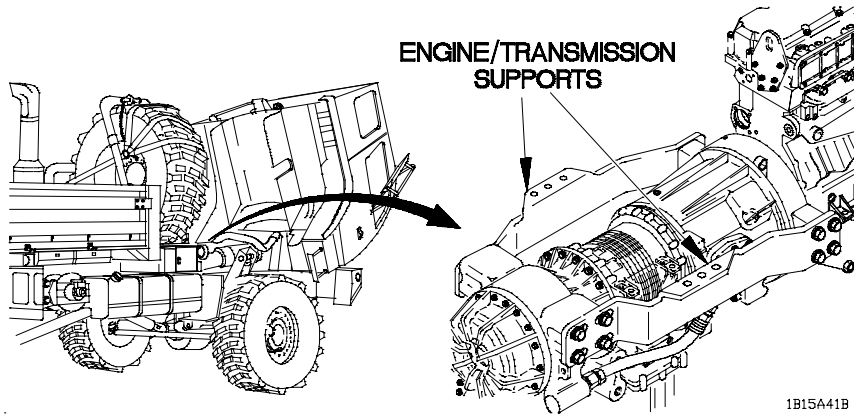
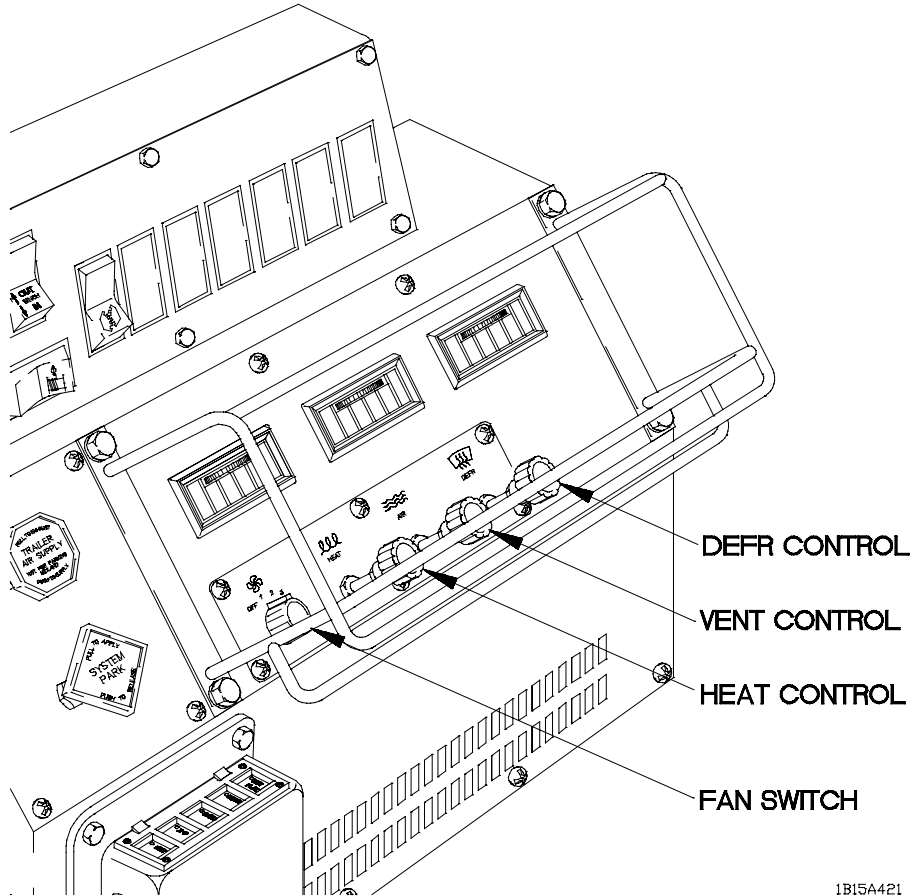


Table 2-1. Preventive Maintenance Checks and Services (All Models) (Cont)

Item No.	Interval	Location	Crewmember Procedure	Not Fully Mission Capable If:
		Item to Check/Service		
<div style="border: 1px solid black; padding: 5px; width: fit-content; margin: 0 auto;">WARNING</div> <p>Wear heavy leather-palmed work gloves when handling cable. Cables can become frayed or contain broken wires. Never let moving cable slide through hands, even when wearing gloves. Failure to comply may result in serious injury or death to personnel.</p>				
44	Weekly	11K SRW Operation (If Equipped)	a. Check 11K SRW for proper operation in both directions (para 2-54).	
			<p>b. Check cable for kinks, frays, and breaks.</p> <p>c. Check cable end for missing or damaged pin or cotter pin.</p>	

Table 2-1. Preventive Maintenance Checks and Services (All Models) (Cont)

Item No.	Interval	Location	Crewmember Procedure	Not Fully Mission Capable If:
		Item to Check/Service		
45	Weekly	Heater/Defrost Controls	Check FAN switch, HEAT control, VENT control, and DEFR (defrost) control for proper operation (para 2-25).	



1B15A421

Table 2-1. Preventive Maintenance Checks and Services (All Models) (Cont)

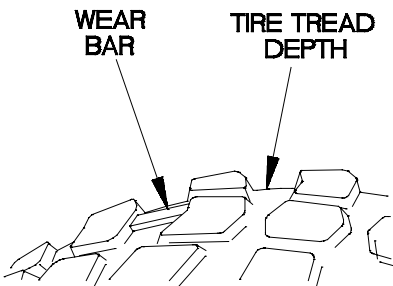
Item No.	Interval	Location	Crewmember Procedure	Not Fully Mission Capable If:
		Item to Check/Service		
 <p style="text-align: right;">1B15A45B</p>				
46	Weekly	Wheels and Tires	<p>a. Check tire tread depth. Tread should not be worn beyond level of wear bar.</p> <p>b. Check wheel assembly for damage. If damaged, remove wheel and check wheel for cracked, broken, or bent surfaces.</p>	<p>a. Tire tread is worn even to height of tread bar (depth is 1/8 in. (3 mm) or less). Any cut, gouge, or crack that extends to cord body or any unusual bulges.</p> <p>b. Wheel is cracked, broken, or bent.</p>

Table 2-1. Preventive Maintenance Checks and Services (All Models) (Cont)

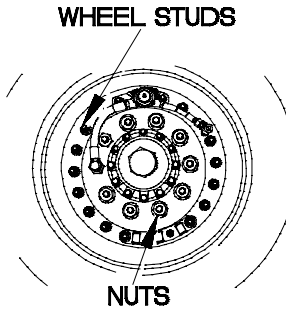
Item No.	Interval	Location	Crewmember Procedure	Not Fully Mission Capable If:
		Item to Check/Service		
 <p>1B15A46B</p>				
46	Weekly	Wheels and Tires (Cont)	<p>c. Check wheel studs and nuts for obvious looseness. Check for bent or broken studs and missing or loose nuts. Notify Unit Maintenance if any nuts are loose or missing or if any studs are broken or bent.</p> <p>d. Check tire pressures with tire gage for each CTIS setting. Notify Unit Maintenance if tire pressures are not within +/- 3 psi (21 kPa) of the values given below:</p> <p>MODE</p> <p>HWY 55 psi (379 kPa)</p> <p>X-C 33 psi (228 kPa)</p> <p>SAND 20 psi (138 kPa)</p> <p>EMER 14 psi (97 kPa)</p>	c. Two or more nuts or studs on same wheel are missing, loose, or broken.

Table 2-1. Preventive Maintenance Checks and Services (All Models) (Cont)

Item No.	Interval	Location	Crewmember Procedure	Not Fully Mission Capable If:
		Item to Check/Service		
<p style="text-align: right;">1B15A47B</p>				
47	Weekly	Hydraulic Reservoir (If Equipped)	<p>a. Check hydraulic reservoir, oil hoses, and connections for leaks and/or damage.</p> <p>b. Check for clogged, damaged, or missing hydraulic reservoir strainer.</p> <ol style="list-style-type: none"> (1). Remove cap from hydraulic reservoir. (2). Wipe out inside of hydraulic reservoir strainer with clean rag. (3). Install cap on hydraulic reservoir. 	a. Class III leak is evident.

Table 2-1. Preventive Maintenance Checks and Services (All Models) (Cont)

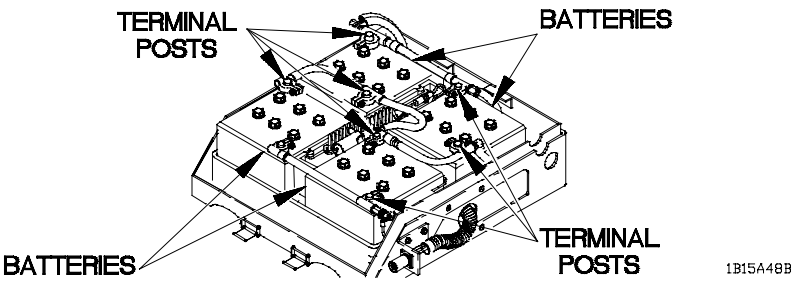
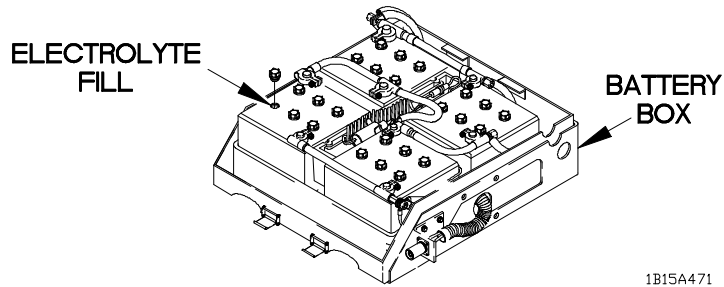
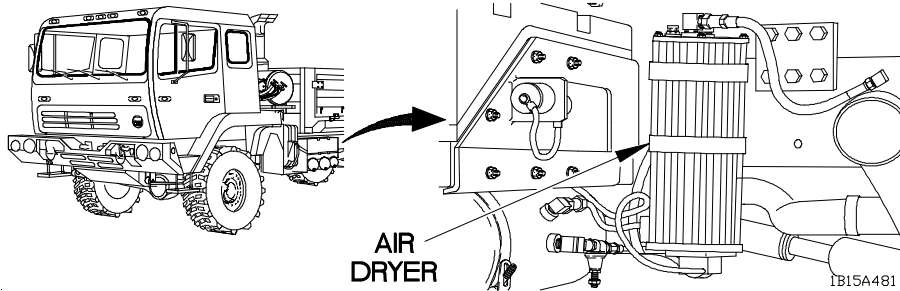
Item No.	Interval	Location	Crewmember Procedure	Not Fully Mission Capable If:
		Item to Check/Service		
				
<div style="border: 1px solid black; padding: 5px; width: fit-content; margin: 0 auto;">WARNING</div> <ul style="list-style-type: none"> • Lead-acid battery gases can explode. Do not smoke, have open flames, or make sparks around a battery, especially if caps are off. Battery may give off gas which can explode. Failure to comply may result in serious injury or death to personnel. • Remove rings, bracelets, wristwatches, neck chains, and any other jewelry before working around vehicle. Jewelry may catch on equipment or may short across and electrical circuit. Failure to comply may result in injury to personnel. 				
<div style="border: 1px solid black; padding: 5px; width: fit-content; margin: 0 auto;">CAUTION</div> <p>When operating in outside temperatures above 90°F (32°C), battery fluid levels must be checked daily. Failure to comply may result in damage to equipment.</p>				
48	Weekly	Batteries	<ol style="list-style-type: none"> a. Open battery cover (para 3-8a). b. Check batteries for damaged casing, terminal posts, and security of mounting. Check that battery cable clamps are secure. Notify Unit Maintenance if any defects are found. 	<ol style="list-style-type: none"> b. One or more batteries are missing, unserviceable, or leaking. Battery cable clamps are loose.

Table 2-1. Preventive Maintenance Checks and Services (All Models) (Cont)

Item No.	Interval	Location	<u>Crewmember Procedure</u>	Not Fully Mission Capable If:
		Item to Check/Service		
48	Weekly	Batteries (Cont)	<p>c. Check battery fluid level (para 3-8b). If fluid level is low notify Unit Maintenance. If fluid is gassing (to boiling), notify Unit Maintenance.</p> <p>d. Check battery box for corrosion. Clean debris from battery box drain holes.</p> <p>e. Close battery cover (para 3-8c).</p>	
49	Weekly	Air Dryer	Check air dryer for damage and loose mounting.	



1B15A471



1B15A481

Table 2-1. Preventive Maintenance Checks and Services (All Models) (Cont)

Item No.	Interval	Location	Crewmember Procedure	Not Fully Mission Capable If:
		Item to Check/Service		
50	Weekly	Underneath Vehicle	<ul style="list-style-type: none"> a. Check underneath vehicle for obvious damage to leaf springs, engine, transmission, frame rails, and crossmembers. b. Check air hoses and fittings underneath vehicle for obvious damage and leakage. c. Check shock absorbers for leaks, missing or loose hardware and loose shock absorbers. 	<ul style="list-style-type: none"> a. Any loose or broken frame rails, crossmembers, broken welds, or broken screws are found. b. Any air leaks or damage to hose or fittings are found. c. Any oil leaks greater than class I, missing or loose hardware, or loose shock absorbers are found.

Table 2-1. Preventive Maintenance Checks and Services (All Models) (Cont)

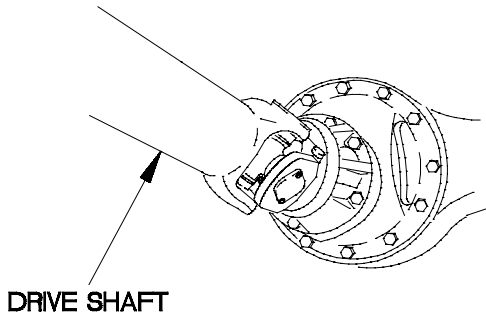
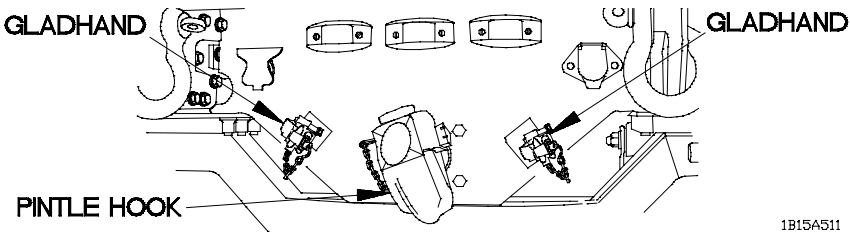
Item No.	Interval	Location	Crewmember Procedure	Not Fully Mission Capable If:
		Item to Check/Service		
		 <p style="text-align: right;">1B15A52B</p>		
50	Weekly	Underneath Vehicle (Cont)	<p>d. Check drive shafts for loose hardware.</p> <p>e. Inspect drive shaft for excessive play. If drive shaft has excessive play, Notify Unit Maintenance to perform hinging check.</p>	d. Any loose hardware is found.
		 <p style="text-align: right;">1B15A511</p>		
51	Weekly	Electrical Connectors	Check electrical connectors for damage.	
52	Weekly	Rear Gladhands	a. Check rear gladhands for damage and air leaks.	a. Air leaks are heard.

Table 2-1. Preventive Maintenance Checks and Services (All Models) (Cont)

Item No.	Interval	Location	<u>Crewmember Procedure</u>	Not Fully Mission Capable If:
		Item to Check/ Service		
53	Weekly	Reflectors	b. Lubricate coupler seals (Appendix F, Note 8). Check for missing or damaged reflectors.	
54	Weekly	Pintle Hook	Check pintle hook for looseness and/or damaged locking mechanism.	

Table 2-1. Preventive Maintenance Checks and Services (All Models) (Cont)

Item No.	Interval	Location	Crewmember Procedure	Not Fully Mission Capable If:
		Item to Check/Service		
55	Weekly	Shackles	Check shackles for damage. Check mounting pin for damage.	

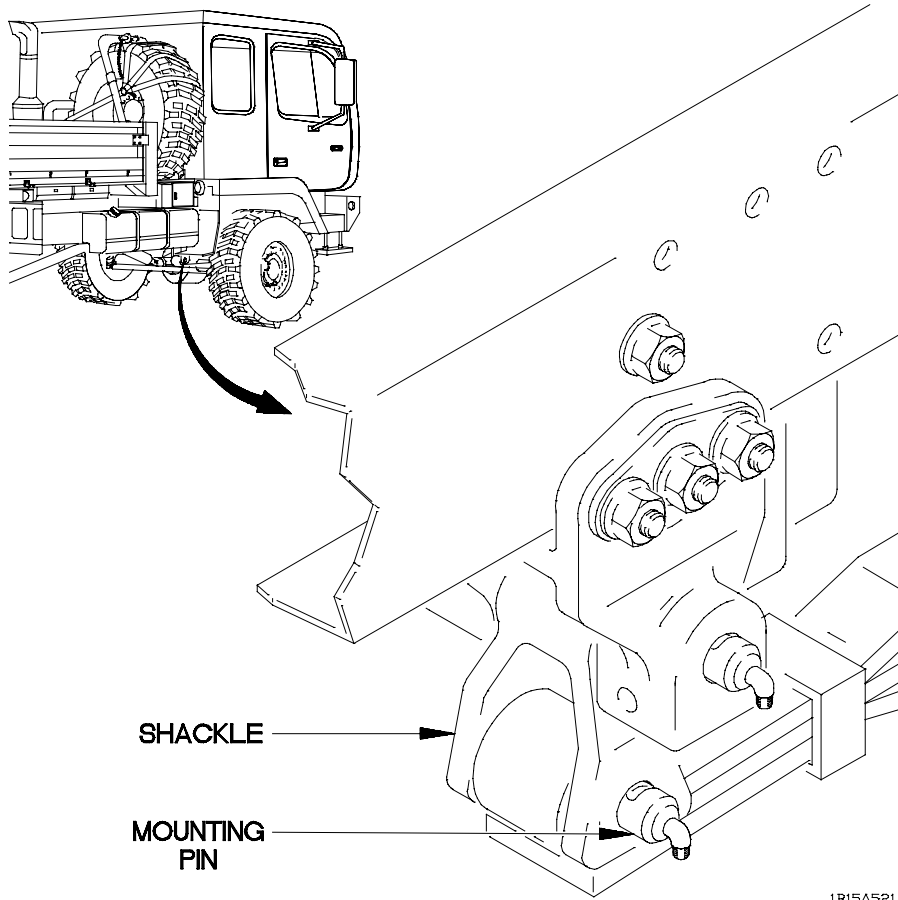


Table 2-1. Preventive Maintenance Checks and Services (All Models) (Cont)

Item No.	Interval	Location	Crewmember Procedure	Not Fully Mission Capable If:
		Item to Check/Service		
56	Weekly	11K SRW Rollers (If Equipped)	Check that cable guides and roller fairleads are mounted securely and rotate smoothly.	
57	Weekly	11K SRW (If Equipped)	Inspect 11K SRW for loose parts, oil leaks, and obvious external damage.	

Table 2-1. Preventive Maintenance Checks and Services (All Models) (Cont)

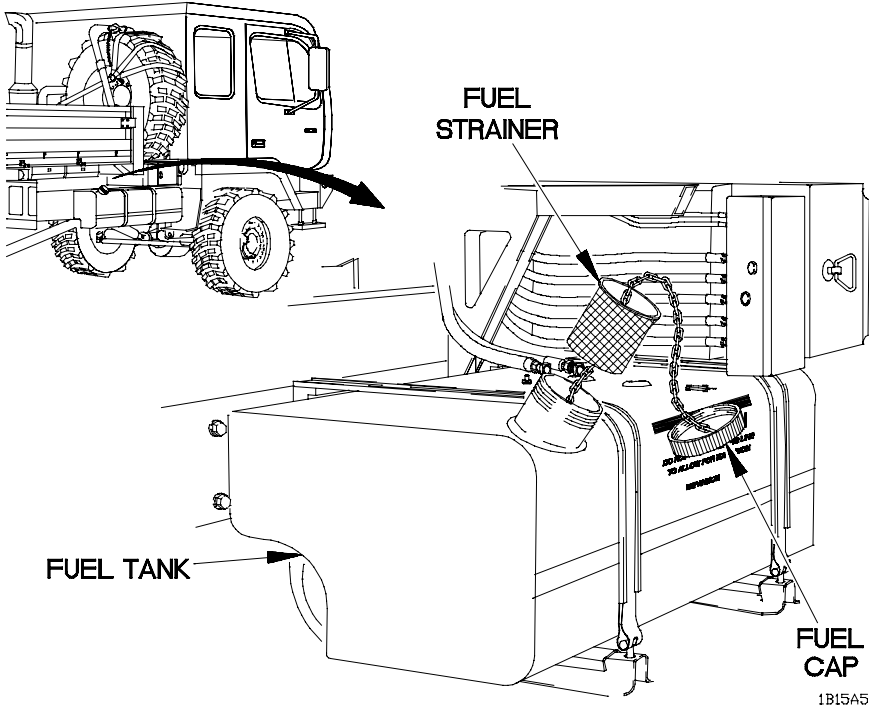
Item No.	Interval	Location	Crewmember Procedure	Not Fully Mission Capable If:
		Item to Check/Service		
 <p style="text-align: center;">WARNING</p> <p>Diesel fuel is flammable. Do not fill fuel tank with engine running, while smoking, or when near an open flame. Never overfill tank or spill fuel. If fuel is spilled, clean it up immediately. Failure to comply may result in serious injury or death to personnel.</p>				
58	Weekly	Fuel Tank	<ol style="list-style-type: none"> a. Check fuel tank for clogged, damaged, or missing fuel strainer. b. Check that fuel cap is not loose or damaged. 	

Table 2-1. Preventive Maintenance Checks and Services (All Models) (Cont)

Item No.	Interval	Location	Crewmember Procedure	Not Fully Mission Capable If:
		Item to Check/Service		
<p style="text-align: right;">1B15A551</p>				
58	Weekly	Fuel Tank (Cont)	c. Check fuel tank, fuel hoses, and connections for leaks and damage.	c. Class III leak is evident.
<p style="text-align: right;">1B15A561</p>				
59	Weekly	Door, Window, and Mirror	Check condition and operation of doors, windows, and mirrors.	

Table 2-1. Preventive Maintenance Checks and Services (All Models) (Cont)

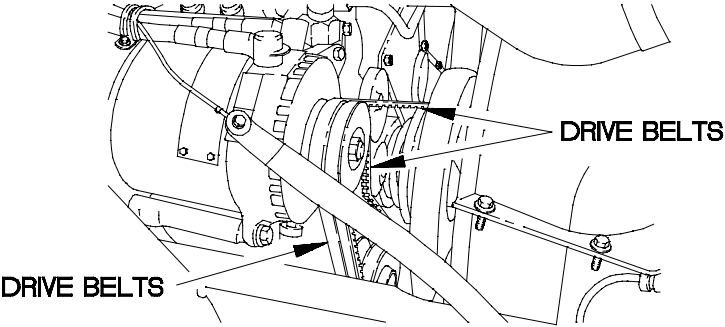
Item No.	Interval	Location	Crewmember Procedure	Not Fully Mission Capable If:
		Item to Check/ Service		
 <p style="text-align: right; margin-right: 50px;">1B15A571</p>				
<div style="border: 1px solid black; padding: 5px; width: fit-content; margin: 0 auto;"> WARNING </div> <ul style="list-style-type: none"> • Ensure engine oil is cool before performing any maintenance. Failure to comply may result in serious injury or death to personnel. • Engine compartment and accessories may be extremely hot when engine is running or has been running recently. Use caution around engine when cab is raised. Failure to comply may result in injury to personnel. • Engine compartment contains a partially exposed fan blade. Use extreme caution around front of engine. Failure to comply may result in injury to personnel. 				
60	Weekly	Drive Belts, Fan, and Pulleys	<ul style="list-style-type: none"> a. Raise cab (para 2-22a). b. Check drive belts for cracking, fraying, and breaks. 	<ul style="list-style-type: none"> b. Any of the following conditions are present:

Table 2-1. Preventive Maintenance Checks and Services (All Models) (Cont)

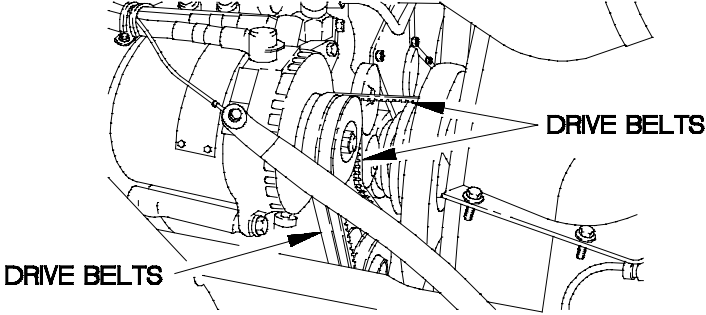
Item No.	Interval	Location	Crewmember Procedure	Not Fully Mission Capable If:
		Item to Check/Service		
				
60	Weekly	Drive Belts, Fan, and Pulleys (Cont)	<p>c. Check tightness of drive belts. Play should be about 1/2 in. (13 mm). Notify Unit Maintenance to tighten drive belts.</p>	<ol style="list-style-type: none"> 1. Any drive belt has more than one crack 1/8 in. (3 mm) in depth or 50 percent of belt thickness. 2. Any drive belt has frays more than 2 in. (51 mm) long. c. Any drive belt has excessive play.

Table 2-1. Preventive Maintenance Checks and Services (All Models) (Cont)

Item No.	Interval	Location	Crewmember Procedure	Not Fully Mission Capable If:
		Item to Check/Service		
61	Weekly	Fan Clutch	Check fan clutch for missing or loose mounting hardware.	Missing or loose mounting hardware is found.
62	Weekly	Radiator Hoses	<p>a. Check radiator hoses for cracks and excessive wear which may cause leakage. Check radiator hoses for loose hose clamps.</p> <p>b. Check radiator for leaks and damaged fins.</p>	<p>a. Class III leak is evident.</p> <p>b. Class III leak is evident.</p>

Table 2-1. Preventive Maintenance Checks and Services (All Models) (Cont)

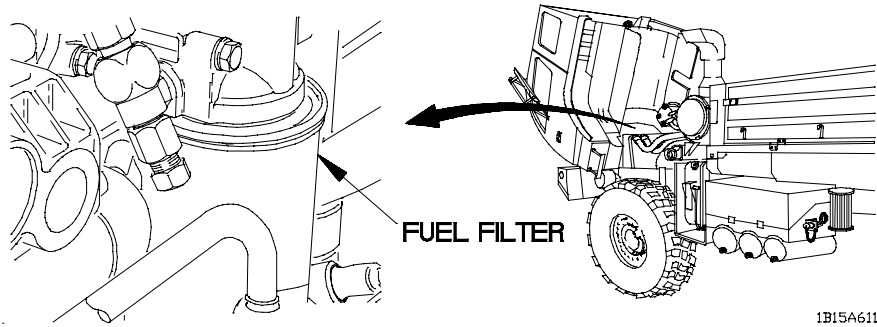
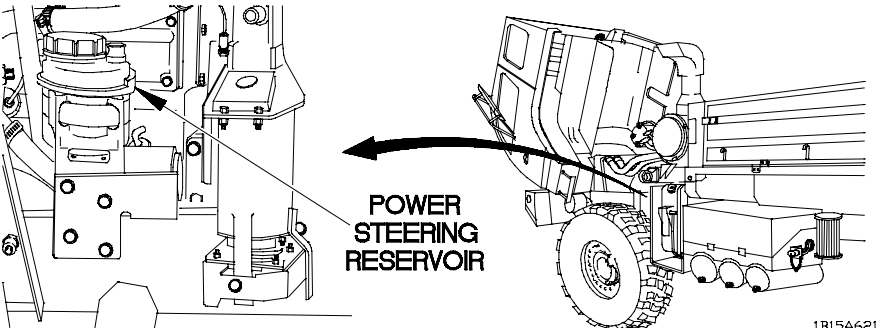
Item No.	Interval	Location	Crewmember Procedure	Not Fully Mission Capable If:	
		Item to Check/Service			
63	Weekly	 <p style="text-align: center;">FUEL FILTER</p> <p style="text-align: right;">1B15A611</p>		Check fuel filter for leaks or damage.	Class III leak is evident.
		 <p style="text-align: center;">POWER STEERING RESERVOIR</p> <p style="text-align: right;">1B15A621</p>	<div style="border: 1px solid black; padding: 5px; text-align: center; width: fit-content; margin: 0 auto;">CAUTION</div> <p>Do not overfill power steering reservoir. Failure to comply may result in damage to equipment.</p>	a. Check power steering reservoir for leaks or obvious damage.	a. Class III leak is evident.

Table 2-1. Preventive Maintenance Checks and Services (All Models) (Cont)

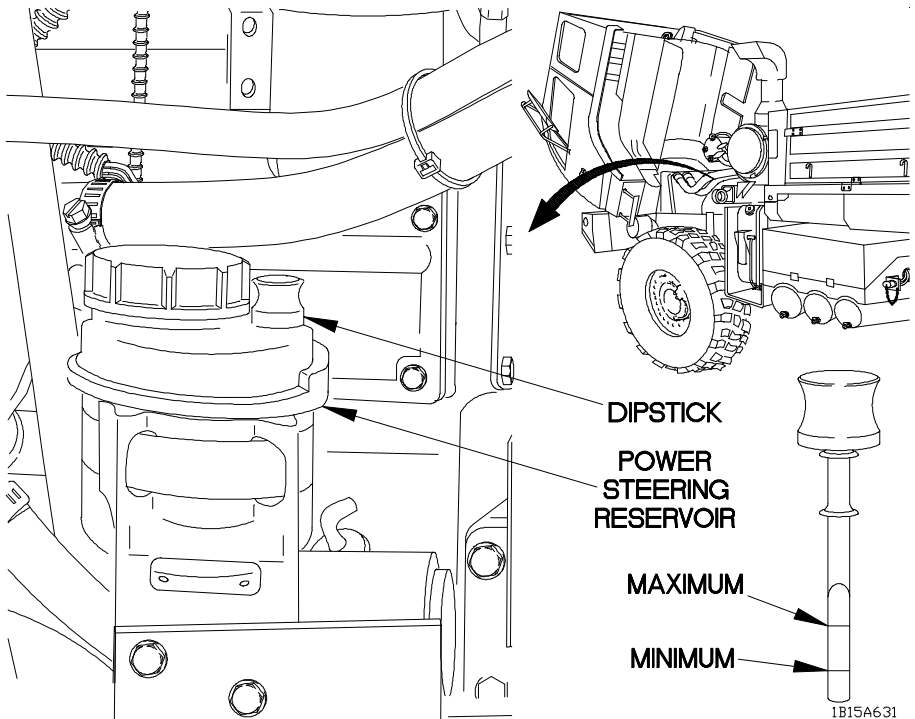
Item No.	Interval	Location	Crewmember Procedure	Not Fully Mission Capable If:
		Item to Check/Service		
64	Weekly	 <p>Power Steering Reservoir (Cont)</p>	<p>b. Check that power steering reservoir is filled to proper level. Oil level should be between maximum and minimum level as marked on dipstick. Add oil as required (Appendix F, Note 7). If oil level is over full mark, notify Unit Maintenance.</p>	

Table 2-1. Preventive Maintenance Checks and Services (All Models) (Cont)

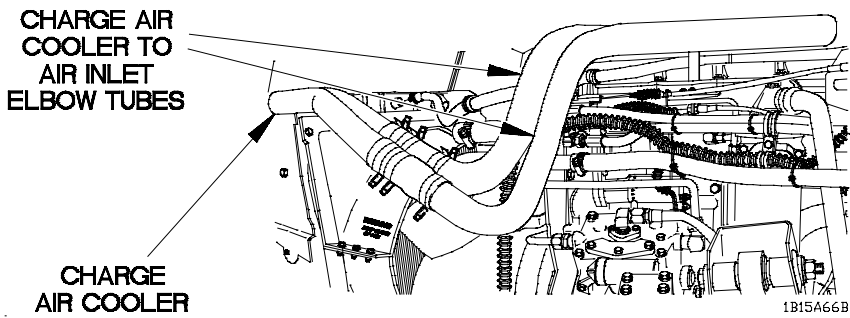
Item No.	Interval	Location	Crewmember Procedure	Not Fully Mission Capable If:
		Item to Check/Service		
65	Weekly	Charge Air	<p>a. Check for missing or loose clamps at:</p> <ul style="list-style-type: none"> (1) Intake air filter. (2) Turbocharger inlet coupling. 	<p>a. Any clamp missing or unable to be tightened.</p>
			<ul style="list-style-type: none"> (3) Charge air cooler. (4) Charge air cooler to air inlet elbow tubes. 	
			 <p>Diagram showing the charge air cooler and charge air cooler to air inlet elbow tubes. Labels include: CHARGE AIR COOLER TO AIR INLET ELBOW TUBES and CHARGE AIR COOLER. Reference number: 1B15A66B.</p>	

Table 2-1. Preventive Maintenance Checks and Services (All Models) (Cont)

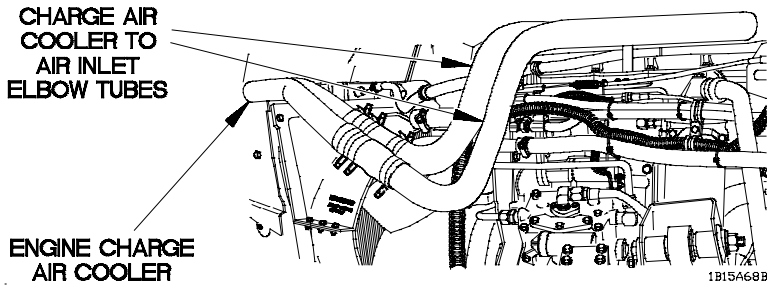
Item No.	Interval	Location	Crewmember Procedure	Not Fully Mission Capable If:
		Item to Check/Service		
65	Weekly	Charge Air (Cont)	b. Check intake air hoses at: <ol style="list-style-type: none"> (1) Intake air filter. (2) Turbocharger inlet coupling. 	b. Any hose with damage.
			<ol style="list-style-type: none"> (3) Charge air cooler. (4) Charge air cooler to air inlet elbow tubes. 	
			 <p style="text-align: right; font-size: small;">1B15A68B</p>	

Table 2-1. Preventive Maintenance Checks and Services (All Models) (Cont)

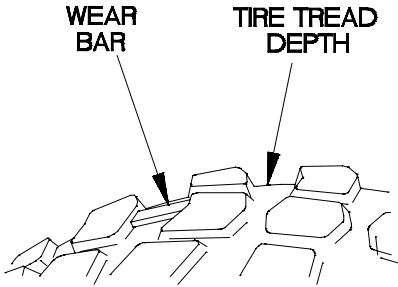
Item No.	Interval	Location	Crewmember Procedure	Not Fully Mission Capable If:
		Item to Check/Service		
 <p>The diagram shows a cross-section of a tire tread. A horizontal line is labeled 'WEAR BAR' with an arrow pointing to it. A vertical line is labeled 'TIRE TREAD DEPTH' with an arrow pointing to the space between the tread blocks and the wear bar.</p>				
1B15A69B				
66	Monthly	Spare Tire	<ul style="list-style-type: none"> a. Check that spare tire lowers properly (para 3-5). b. Check spare tire for cuts, gouges, and cracks. Remove any object that could penetrate tire. c. Check that spare tire has not worn beyond wear bar. Replace spare tire (para 3-5) if tire has worn beyond wear bar. 	<ul style="list-style-type: none"> b. Tire tread is worn even to height of tread bar (depth is 1/8 in. (3 mm) or less). Any cut, gouge, or crack that extends to cord body or any unusual bulges.

Table 2-1. Preventive Maintenance Checks and Services (All Models) (Cont)

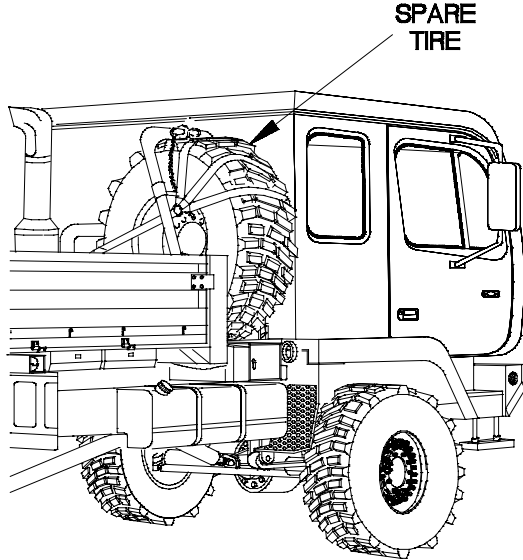
Item No.	Interval	Location	Crewmember Procedure	Not Fully Mission Capable If:
		Item to Check/Service		
 <p style="text-align: right; margin-right: 100px;">1B15A70B</p>				
66	Monthly	Spare Tire (Cont)	<p>d. Check spare tire for correct air pressure. Inflate tire to 60 psi (414 kPa) if air pressure is low.</p> <p>e. Secure spare tire retainer. Ensure spare tire retainer is securely stowed in up position.</p>	<p>e. Spare tire retainer fails to lock in its up position.</p>

Table 2-1. Preventive Maintenance Checks and Services (All Models) (Cont)

Item No.	Interval	Location	Crewmember Procedure	Not Fully Mission Capable If:
		Item to Check/Service		
67	Monthly	Ether Starting Aid	<p>Check ether cylinder for loose or damaged mounts and hardware. Check ether cylinder and injection valve for damage.</p>	
68	Monthly	Rifle Stowage Mount	<p>a. Check that rifle stowage top mount and lower mount bolts are not broken or missing.</p>	

Table 2-1. Preventive Maintenance Checks and Services (All Models) (Cont)

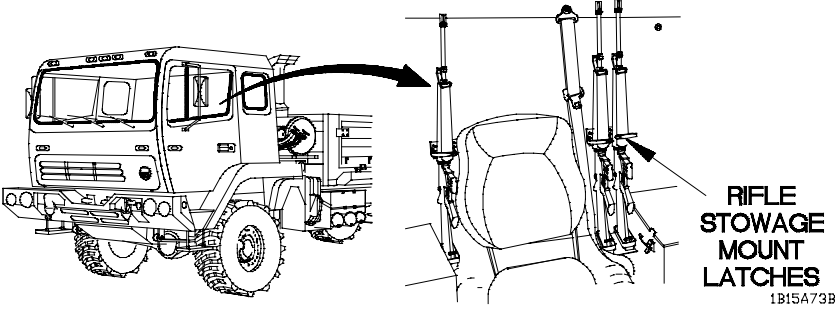
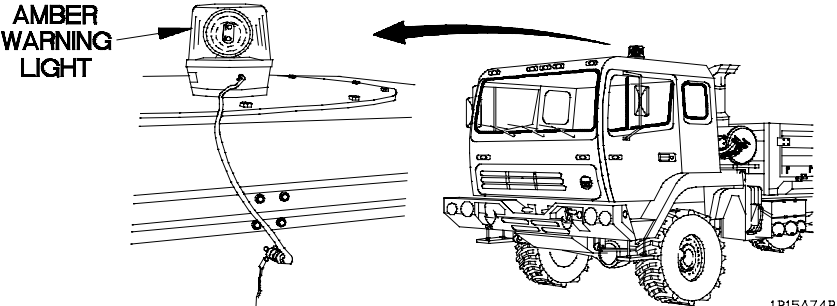
Item No.	Interval	Location	Crewmember Procedure	Not Fully Mission Capable If:		
		Item to Check/ Service				
68	Monthly				<p>b. Check rifle storage mount latches for excessive looseness or binding.</p>	
		Rifle Storage Mount (Cont)				
69	Monthly				<p>NOTE</p> <p>Checking amber warning light is a safety task that would not be performed in a tactical mission. See AR 385-55.</p>	
		Amber Warning Light (If Equipped)	Check vehicle amber warning light for proper operation (para 2-21).			

Table 2-1. Preventive Maintenance Checks and Services (All Models) (Cont)

Item No.	Interval	Location	Crewmember Procedure	Not Fully Mission Capable If:
		Item to Check/ Service		
70	Monthly	Hydraulic Manifold	Inspect hydraulic manifold for leakage.	Class III leak is evident.
71	Monthly	Back-up Hydraulic Pump	<ol style="list-style-type: none"> a. Remove handle from tool box and install in back-up hydraulic pump. b. Pump back-up hydraulic pump 5-8 cycles (to lubricate seals). 	
72	Monthly	Tool Box	Check inside tool box for water in bottom of tool box or other obvious damage. Clean inside tool box with wiping rag, as necessary.	

Table 2-1. Preventive Maintenance Checks and Services (All Models) (Cont)

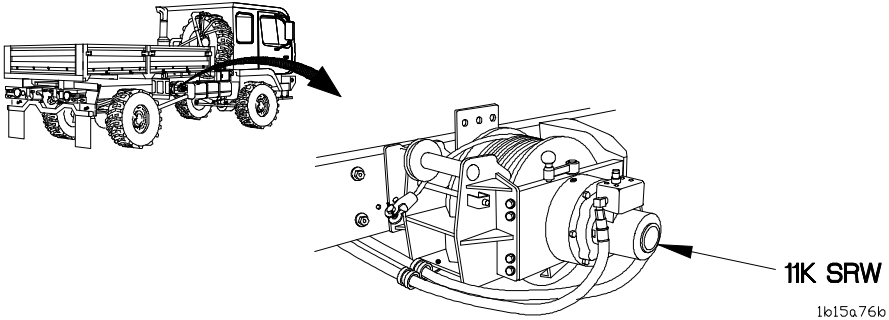
Item No.	Interval	Location	Crewmember Procedure	Not Fully Mission Capable If:
		Item to Check/Service		
 <p>11K SRW 1b15a76b</p>				
<div style="border: 1px solid black; padding: 5px; width: fit-content; margin: 0 auto;">WARNING</div> <p>Wear heavy leather-palmed work gloves when handling cable. Cables can become frayed or contain broken wires. Never let moving cable slide through hands, even when wearing gloves. Failure to comply may result in serious injury or death to personnel.</p>				
73	Monthly	11K SRW Cable (If Equipped)	<ul style="list-style-type: none"> a. Pay out cable completely (para 2-54). b. Inspect wire rope, using FM 5-125. c. Check security of winch mounting hardware. 	b. If Wire rope fails inspection criteria.

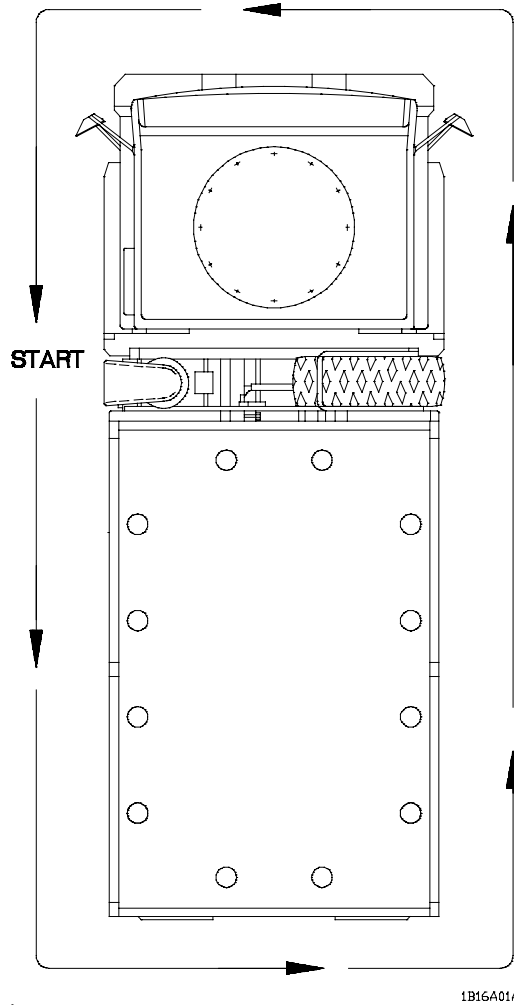
Table 2-1. Preventive Maintenance Checks and Services (All Models) (Cont)

Item No.	Interval	Location	Crewmember Procedure	Not Fully Mission Capable If:
		Item to Check/Service		
<p>The diagram shows a side view of a truck with several callout arrows pointing to specific maintenance points. One arrow points to a grease fitting on the cab lift cylinder, labeled 'GREASE FITTING'. Another arrow points to U-bolts on the front lifting beam, labeled 'U-BOLTS'. There are also arrows pointing to spreader bars and oil can points on the truck's chassis.</p>				
74	Monthly	Cab Lift Cylinder	Lubricate grease fitting (Appendix F, Note 11).	
75	Monthly	Front Lifting Beam	Lubricate front lifting beam (Appendix F, Note 9).	
76	Monthly	Spreader Bars	Lubricate spreader bars (Appendix F, Note 10).	
77	Monthly	Oil Can Points	Lubricate all oil can points listed in Appendix F, Note 5.	

1B15A77B

**2-16. PREVENTIVE MAINTENANCE CHECKS AND SERVICES
TABLE (M1078 AND M1081)**

Refer to Table 2-2. Preventive Maintenance Checks and Services (PMCS) for Operator/Crew PMCS procedures common to vehicle models M1078 and M1081. The PMCS routing diagram is shown below. It shows the vehicle PMCS routing track which matches the sequence of PMCS given in Table 2-2.

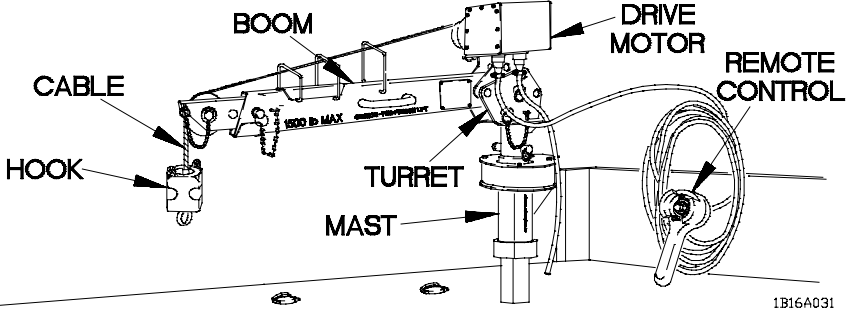


PMCS ROUTING DIAGRAM

Table 2-2. Preventive Maintenance Checks and Services (M1078 and M1081)
(Cont)

Item No.	Interval	Location	Crewmember Procedure	Not Fully Mission Capable If:
		Item to Check/Service		
1	Before	Troop Transport Alarm Switch (If equipped)	<ul style="list-style-type: none"> a. Check that attaching knobs are tight. b. Position master power switch to on (para 2-21a or b). c. Position troop transport alarm switch to ON (para 2-9a). d. Verify that audible alarm sounds in cab. e. Position troop transport alarm switch to OFF (para 2-9a). f. Position master power switch to off (para 2-21f). 	

**Table 2-2. Preventive Maintenance Checks and Services (M1078 and M1081)
(Cont)**

Item No.	Interval	Location	Crewmember Procedure	Not Fully Mission Capable If:
		Item to Check/Service		
				
<p>NOTE</p> <p>LMHC is checked during operation when required as part of vehicle mission.</p>				
2	During	LMHC (if equipped)	<ul style="list-style-type: none"> a. Check for loose, missing, or damaged drive motor mounting bolts. Tighten loose bolts. If bolts are missing, damaged, or can not be tightened, notify Unit Maintenance. b. Using LMHC remote control, check that cable pays out and reels in properly (para 2-24). c. Rotate LMHC to right and to left, checking for binding or any restriction to movement of all LMHC components (para 2-24). 	

**Table 2-2. Preventive Maintenance Checks and Services (M1078 and M1081)
(Cont)**

Item No.	Interval	Location	<u>Crewmember Procedure</u>	Not Fully Mission Capable If:
		Item to Check/ Service		
<div style="border: 1px solid black; padding: 5px; width: fit-content; margin: 0 auto;"> WARNING </div> <p>Wire rope can become frayed or contain broken wires. Wear heavy leather-palmed work gloves when handling wire rope. Never let moving wire rope slide through hands, even when wearing gloves. Failure to comply may result in injury to personnel.</p>				
2	During	LMHC (if equipped) (Cont)	d. Check cable for kinks, frays, and breaks.	d. Evidence of kinks, frays, or breaks.
<p>NOTE</p> <p>LMHC is checked before vehicle operation when required as part of vehicle mission.</p>				
3	Weekly	LMHC (if equipped)	a. Check boom assembly, turret, winch assembly, and mast assembly for damage or broken welds.	a. Boom assembly, turret, winch assembly, or mast assembly are damaged or broken welds are found.

**Table 2-2. Preventive Maintenance Checks and Services (M1078 and M1081)
(Cont)**

Item No.	Interval	Location	<u>Crewmember Procedure</u>	Not Fully Mission Capable If:
		Item to Check/Service		
3	Weekly	LMHC (if equipped) (Cont)	<p>b. Check LMHC power cord for damage or cracks in insulation.</p> <p>c. Check that the following pins are present and not damaged.</p> <p>(1) Pin securing mast to cargo bed.</p> <p>(2) Pin securing boom in raised and lowered positions.</p> <p>(3) Pin securing boom in extended and retracted positions.</p>	<p>b. Any damage or cracks in insulation which expose bare wire.</p> <p>c. One or more pins are missing or damaged.</p>

**Table 2-2. Preventive Maintenance Checks and Services (M1078 and M1081)
(Cont)**

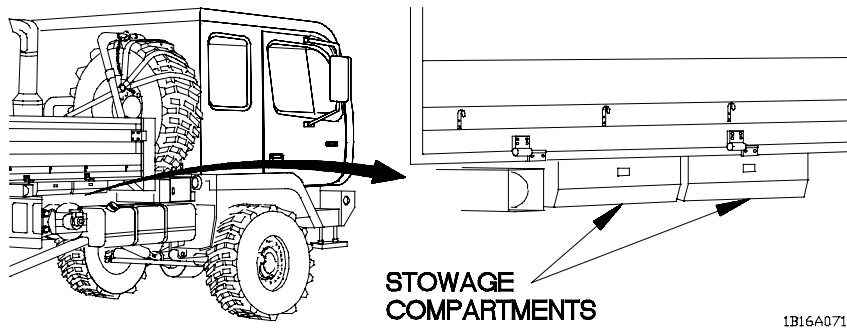
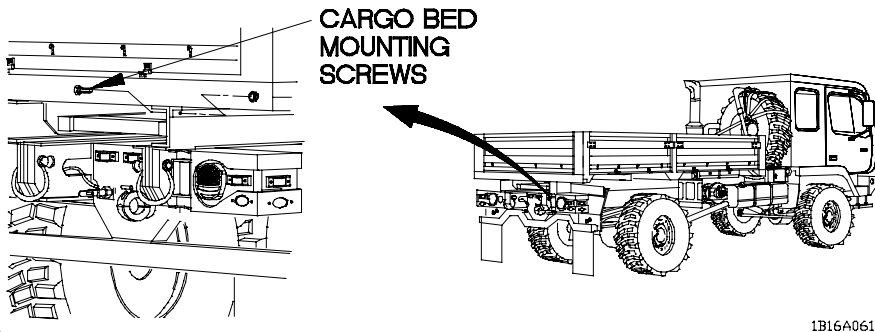
Item No.	Interval	Location	<u>Crewmember Procedure</u>	Not Fully Mission Capable If:
		Item to Check/Service		
4	Deleted			

**Table 2-2. Preventive Maintenance Checks and Services (M1078 and M1081)
(Cont)**

Item No.	Interval	Location	<u>Crewmember Procedure</u>	Not Fully Mission Capable If:
		Item to Check/Service		
4	Deleted			

**Table 2-2. Preventive Maintenance Checks and Services (M1078 and M1081)
(Cont)**

Item No.	Interval	Location	Crewmember Procedure	Not Fully Mission Capable If:
		Item to Check/Service		
5	Weekly	Cargo Bed	<p>a. Check that cargo bed mounting screws on both sides of vehicle are not broken or missing.</p>	<p>a. One or more cargo bed mounting screws are broken or missing.</p>
			<p>b. Check inside panel stowage compartments underneath cargo bed for obvious damage.</p>	



**Table 2-2. Preventive Maintenance Checks and Services (M1078 and M1081)
(Cont)**

Item No.	Interval	Location	Crewmember Procedure	Not Fully Mission Capable If:
		Item to Check/Service		
<p style="text-align: right;">1B16A081</p>				
5	Weekly	Cargo Bed (Cont)	<p>c. Check lift beam on both sides of vehicle for damage. Check that lift beam lock pin is not missing or damaged.</p> <p>d. Check spreader bar on both sides for damage.</p>	<p>c. Lift beam is damaged or lock pin is missing or damaged and lift beam is required for vehicle mission.</p>

Table 2-2. Preventive Maintenance Checks and Services (M1078 and M1081)
(Cont)

Item No.	Interval	Location	Crewmember Procedure	Not Fully Mission Capable If:
		Item to Check/Service		
5	Weekly	Cargo Bed (Cont)	e. Check for missing or damaged cargo bed tiedown rings.	
6	Monthly	Cargo Bed Sides and Tailgate	a. Check that cargo bed sides and tailgate are not bent or damaged.	

**Table 2-2. Preventive Maintenance Checks and Services (M1078 and M1081)
(Cont)**

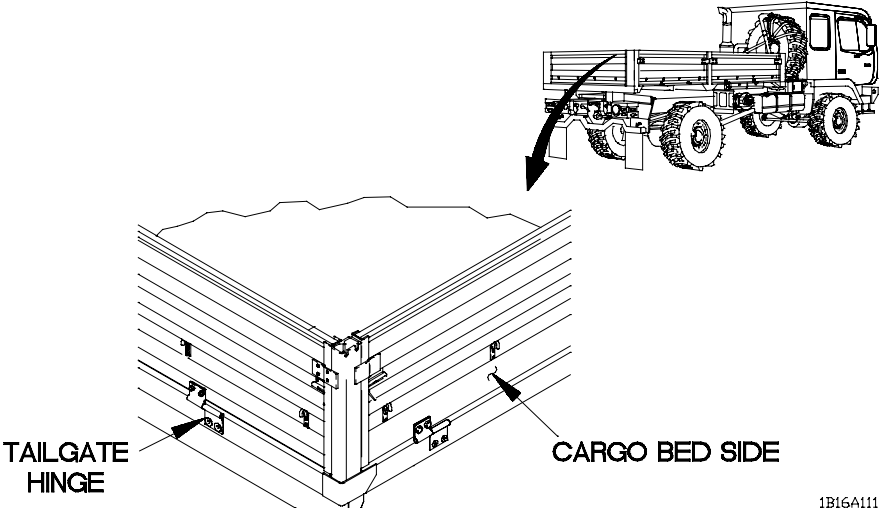
Item No.	Interval	Location	Crewmember Procedure	Not Fully Mission Capable If:
		Item to Check/Service		
 <p style="text-align: right;">1B16A111</p>				
<p>NOTE</p> <p>Hinges and latches on cargo bed sides and tailgate are the same.</p>				
6	Monthly	Cargo Bed Sides and Tailgate (Cont)	<p>b. Check cargo bed sides and tailgate hinges for damage and broken welds.</p> <p>c. Check cargo bed sides and tailgate for missing or damaged latches. Ensure that latches securely lock cargo bed sides and tailgate in raised position.</p>	<p>b. Cargo bed side or tailgate hinge is damaged or weld is broken.</p> <p>c. Latch is missing, damaged, or does not securely lock cargo bed side or tailgate in raised position.</p>

Table 2-2. Preventive Maintenance Checks and Services (M1078 and M1081)
(Cont)

Item No.	Interval	Location	Crewmember Procedure	Not Fully Mission Capable If:
		Item to Check/Service		
7	Monthly	Ladder	<ol style="list-style-type: none"> a. Remove ladder from stowage compartment (para 2-26a). b. Check ladder for cracked or broken welds. c. Stow ladder in stowage compartment (para 2-26b). 	

**Table 2-2. Preventive Maintenance Checks and Services (M1078 and M1081)
(Cont)**

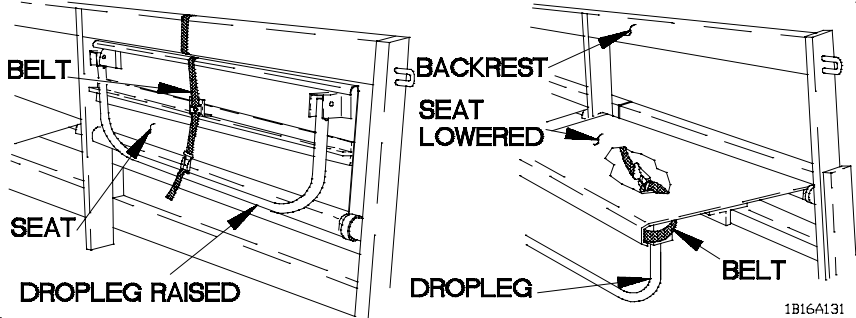
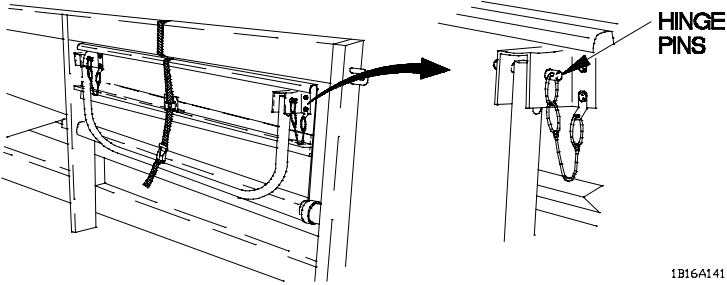
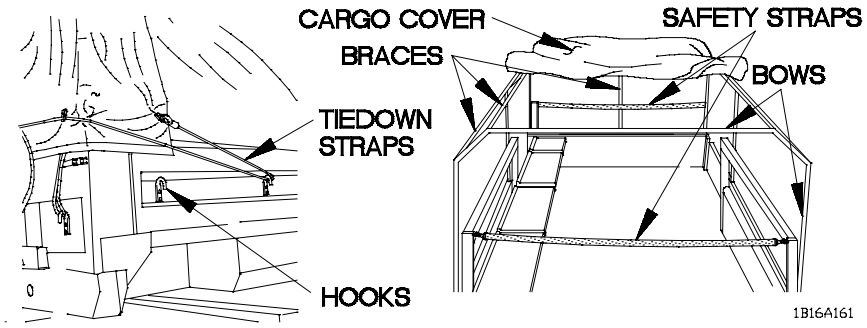
Item No.	Interval	Location	Crewmember Procedure	Not Fully Mission Capable If:
		Item to Check/Service		
 <p style="text-align: right; margin-right: 50px;">1B16A131</p> <p style="text-align: center;">NOTE</p> <p style="text-align: center;">Troopseats are checked before vehicle operation only as required to perform mission.</p>				
8	Monthly	Troopseats (if equipped)	<p>a. Check that troopseat drop legs are not bent or damaged.</p>	<p>a. Drop leg(s) is bent or damaged.</p>
 <p style="text-align: right; margin-right: 50px;">1B16A141</p>				
			<p>b. Check that drop leg hinge pins are not missing or damaged.</p>	<p>b. One or more drop leg hinge pins are missing.</p>

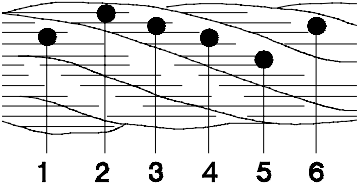
Table 2-2. Preventive Maintenance Checks and Services (M1078 and M1081)
(Cont)

Item No.	Interval	Location	Crewmember Procedure	Not Fully Mission Capable If:
		Item to Check/Service		
8	Monthly	Troopseats (if equipped) (Cont)	<ul style="list-style-type: none"> c. Check if seat assembly and/or backrest are damaged. d. Check that belts are not missing or damaged. e. Check that belt keeps seat assembly securely in raised and lowered positions. 	<ul style="list-style-type: none"> c. Seat assembly and/or backrest are damaged.

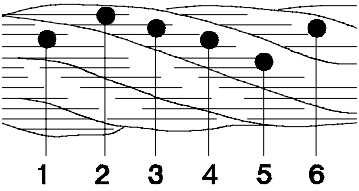
**Table 2-2. Preventive Maintenance Checks and Services (M1078 and M1081)
(Cont)**

Item No.	Interval	Location	Crewmember Procedure	Not Fully Mission Capable If:
		Item to Check/Service		
 <p style="text-align: center;">NOTE</p> <p>Cargo cover is checked before vehicle operation only if required to perform vehicle mission.</p>				
9	Monthly	Cargo Cover	<ul style="list-style-type: none"> a. Check for missing, damaged, or bent bows and braces. b. Check cargo cover for tears and ripped seams that would interfere with proper operation. c. Check that hooks used to secure cargo cover tiedown straps are secure and are not damaged. d. Check that safety straps are not missing or damaged. 	d. Any straps are missing or damaged.

**Table 2-2. Preventive Maintenance Checks and Services (M1078 and M1081)
(Cont)**

Item No.	Interval	Location	Crewmember Procedure	Not Fully Mission Capable If:
		Item to Check/Service		
10	Monthly	LMHC (if equipped)	<p>a. Check LMHC for corrosion, cracks, and security mounting hardware.</p> <div style="text-align: center;">  </div> <p style="text-align: right; margin-right: 100px;">1B16A171</p> <div style="text-align: center; border: 1px solid black; padding: 5px; width: fit-content; margin: 10px auto;"> WARNING </div> <p>Wire rope can become frayed or contain broken wires. Wear heavy leather-palmed work gloves when handling wire rope. Failure to comply may result in injury to personnel.</p>	<p>a. LMHC is damaged or not securely mounted.</p>
			<p>b. Pay out cable completely and inspect for kinks, sharp bends, abrasions, and broken wires (para 2-24).</p>	<p>b. Cable is damaged or excessively worn.</p>

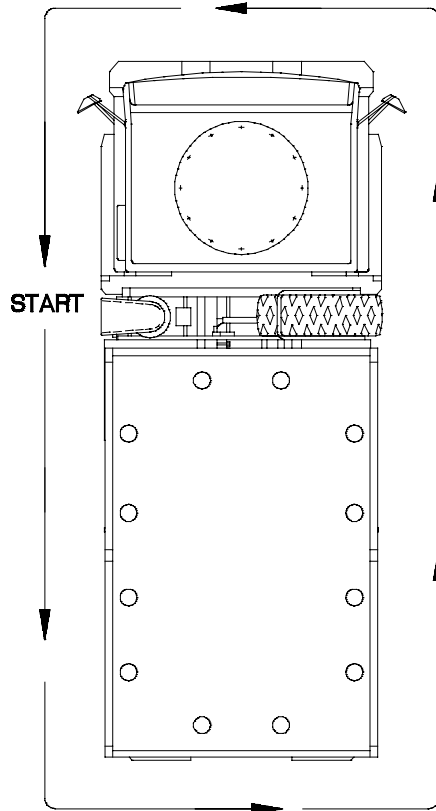
**Table 2-2. Preventive Maintenance Checks and Services (M1078 and M1081)
(Cont)**

Item No.	Interval	Location	Crewmember Procedure	Not Fully Mission Capable If:
		Item to Check/ Service		
10	Monthly	LMHC (if equipped) (Cont)	<p>c. Six randomly distributed broken wires in any 6 in. (150 mm) section of cable or three broken wires in on bundle (breaks 3,4,5) in a 6 in. (150 mm) section.</p>  <p>The diagram shows a cross-section of a cable with six numbered points (1-6) indicating broken wires. Point 1 is at the top left, 2 is at the top center, 3 is at the top right, 4 is at the middle left, 5 is at the middle right, and 6 is at the bottom center. Each point has a small black circle above it, representing a broken wire.</p>	
			<p>d. Kinking, crushing, or any other damage resulting in distortion of the cable structure.</p> <p>e. Check security of electrical connectors on overload shutdown box.</p> <p>f. Inspect electrical cables for cracking, fraying, and chaffing.</p>	<p>f. Wiring is frayed, cracked, or excessively worn.</p>

1B16A181

**2-17. PREVENTIVE MAINTENANCE CHECKS AND SERVICES
TABLE (M1081 AIR DROP SPECIFIC)**

Refer to Table 2-3. Preventive Maintenance Checks and Services (PMCS) for Operator/Crew procedures for vehicle model M1081. The PMCS routing diagram is shown below. It shows the vehicle PMCS routing track which matches the sequence of PMCS given in Table 2-3.



1B17A011

PMCS ROUTING DIAGRAM

Table 2-3. Preventive Maintenance Checks and Services (M1081)

Item No.	Interval	Location	Crewmember Procedure	Not Fully Mission Capable If:
		Item to Check/Service		
<p style="text-align: right;">1B17A021</p>				
1	Weekly	Hinges	Check that hinges are secure and not damaged.	
2	Weekly	Retainer Pins and Buffer Housings	Check that retainer pins and buffer housings are secure and not damaged.	

Table 2-3. Preventive Maintenance Checks and Services (M1081) (Cont)

Item No.	Interval	Location	Crewmember Procedure	Not Fully Mission Capable If:
		Item to Check/Service		
3	Weekly	Latches	<ul style="list-style-type: none"> a. Check that door latches are secure and not damaged. b. Check that windshield latches are secure and not damaged. 	

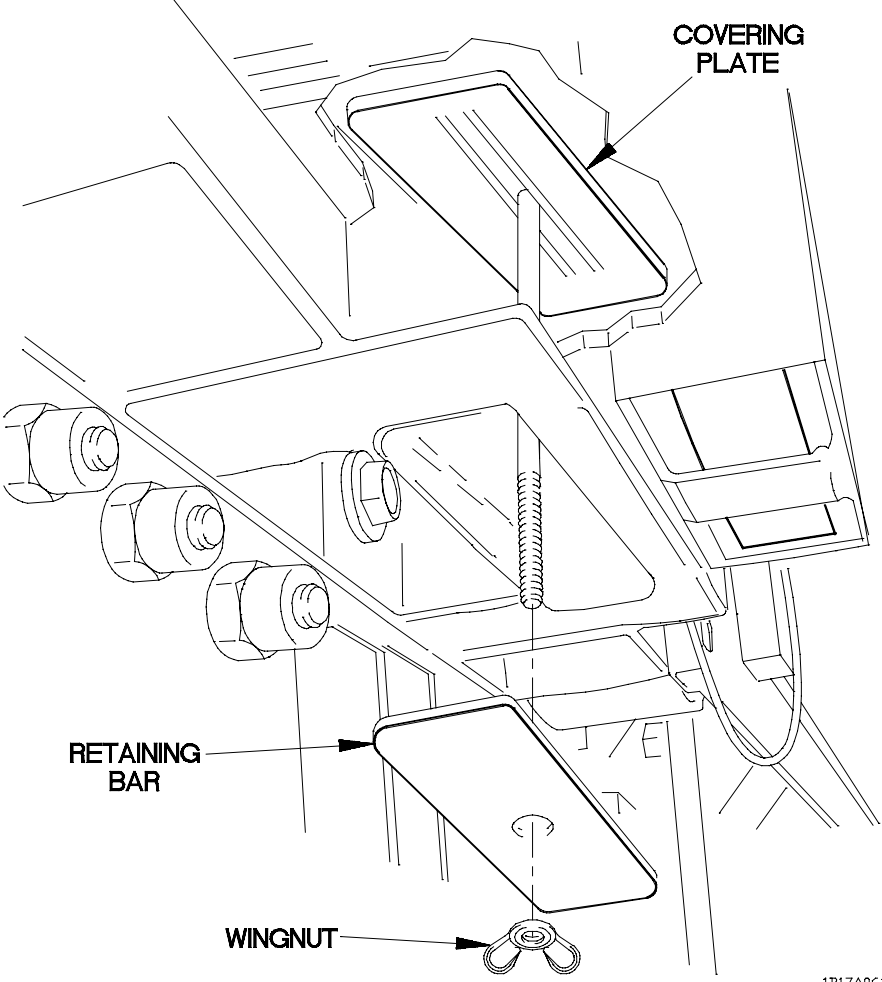
Table 2-3. Preventive Maintenance Checks and Services (M1081) (Cont)

Item No.	Interval	Location	Crewmember Procedure	Not Fully Mission Capable If:
		Item to Check/Service		
4	Weekly	Davit	<ul style="list-style-type: none"> a. Check davit for damage. b. Check that three clamps lock davit in the stowed position. c. Check that davit safety washer and safety pin are present. 	<ul style="list-style-type: none"> a. Davit boom is damaged or missing. b. Any clamp is damaged or missing. c. Davit safety washer or pin is missing.
		<p style="text-align: right;">1B17A041</p>		

Table 2-3. Preventive Maintenance Checks and Services (M1081) (Cont)

Item No.	Interval	Location	Crewmember Procedure	Not Fully Mission Capable If:
		Item to Check/Service		
5	Weekly	Rear Extraction Assembly	<p>a. Check that stabilizer bar and two safety pins are present.</p> <p>b. Check that two tension bars and three safety pins are present.</p>	

Table 2-3. Preventive Maintenance Checks and Services (M1081) (Cont)

Item No.	Interval	Location	Crewmember Procedure	Not Fully Mission Capable If:		
		Item to Check/Service				
6	Weekly				<p>Check that wingnut, retaining bar, and covering plate are present.</p>	
		Slide Assembly				

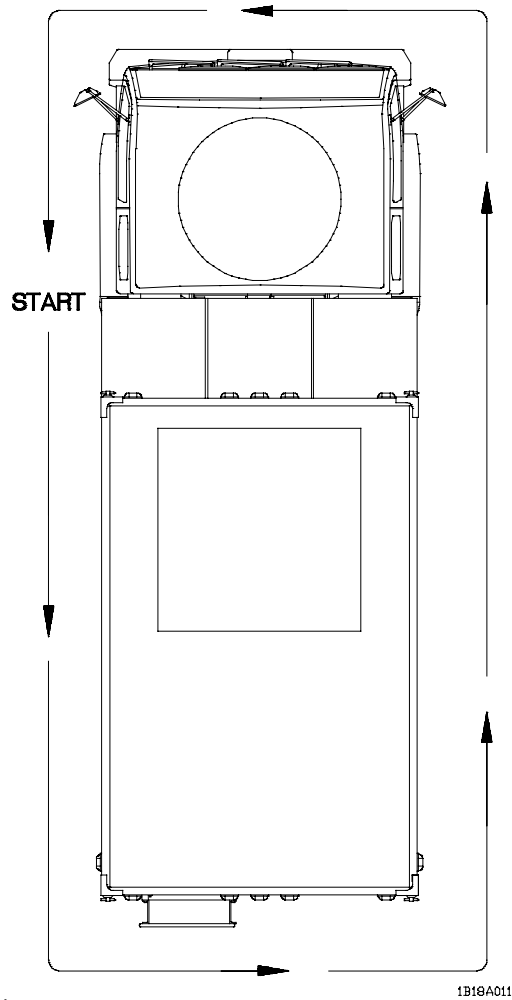
1B17A061

Table 2-3. Preventive Maintenance Checks and Services (M1081) (Cont)

Item No.	Interval	Location	Crewmember Procedure	Not Fully Mission Capable If:
		Item to Check/ Service		
7	Weekly			
		Load Spreader	Check that two load spreaders, four pins, and safety pins are present.	

**2-18. PREVENTIVE MAINTENANCE CHECKS AND SERVICES
TABLE (M1079)**

Refer to Table 2-4 for operator/crew PMCS procedures for M1079 model of the LMTV. The PMCS routing diagram is shown below. It shows the vehicle PMCS routing track which matches the sequence of PMCS given in Table 2-4.



1B18A011

PMCS ROUTING DIAGRAM

Table 2-4. Preventive Maintenance Checks and Services (M1079)

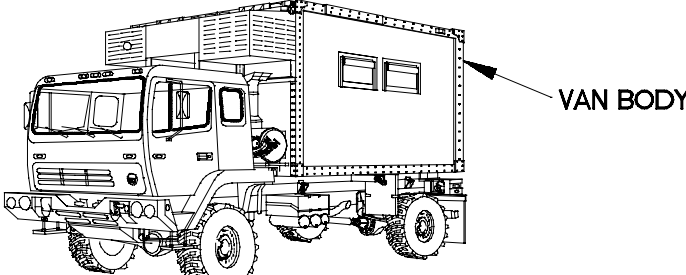
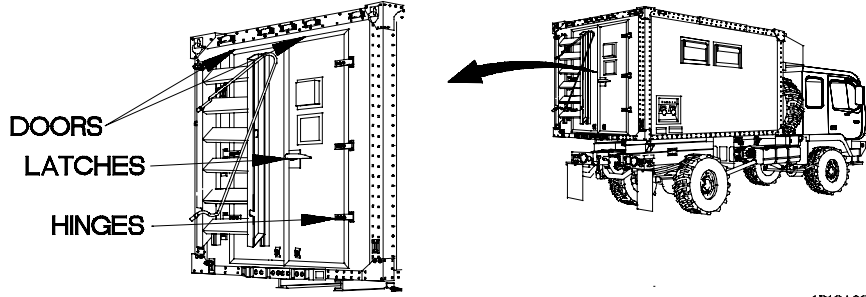
Item No.	Interval	Location	Crewmember Procedure	Not Fully Mission Capable If:
		Item to Check/Service		
 <p style="text-align: right;">1B18A021</p>				
1	Before	Van Body	Inspect van body, windows, and blackout screens for obvious signs of damage	
 <p style="text-align: right;">1B18A031</p>				
2	Before	Van Doors	a. Check door hinges for damage and broken welds.	a. More than one door hinge is damaged or weld is broken.

Table 2-4. Preventive Maintenance Checks and Services (M1079) (Cont)

Item No.	Interval	Location	Crewmember Procedure	Not Fully Mission Capable If:
		Item to Check/ Service		
3	Before	Van Doors (Cont)	<p>b. Check van doors for missing or damaged latches. Check that latches lock securely when doors are closed.</p>	
4	Before	Ladder	<p>a. Lower Ladder (para 2-30a).</p> <p>b. Check ladder mount for damaged or broken welds.</p>	

Table 2-4. Preventive Maintenance Checks and Services (M1079) (Cont)

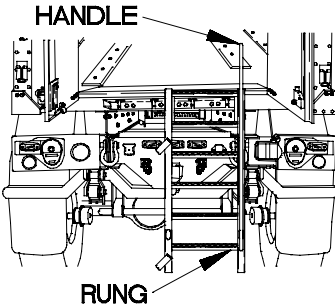
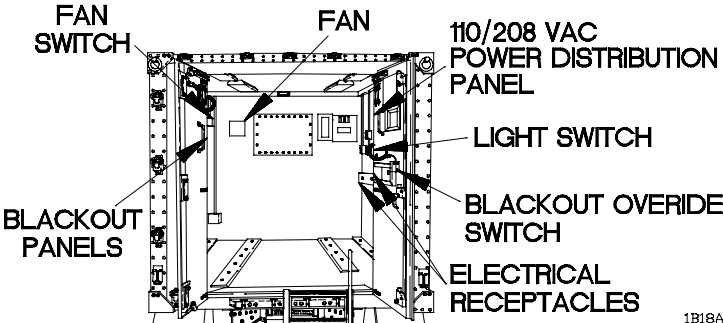
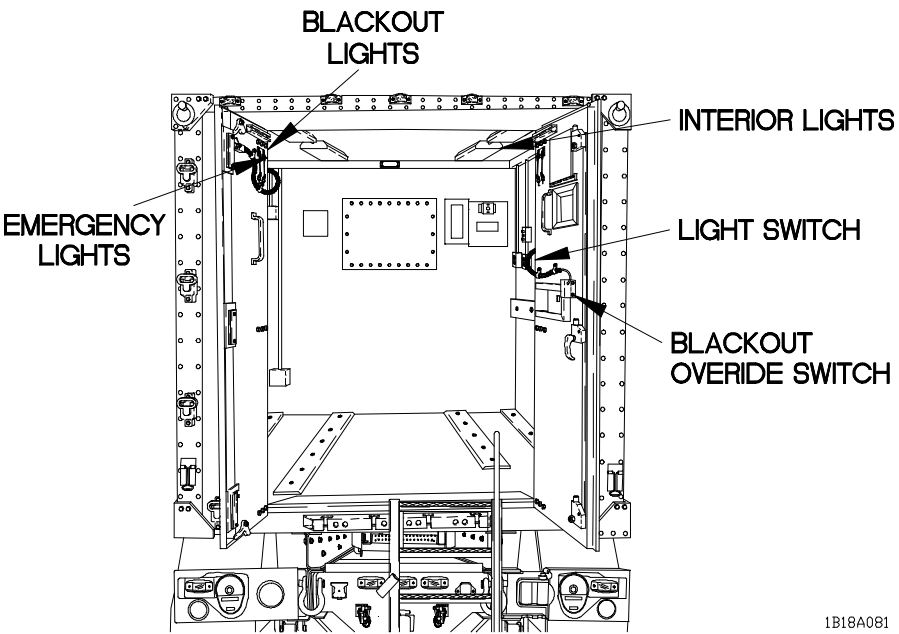
Item No.	Interval	Location	Crewmember Procedure	Not Fully Mission Capable If:
		Item to Check/ Service		
				
5	Before	Ladder (Cont)	c. Check ladder for damaged rungs, damaged handle, and broken welds.	
				
6	Before	Van Body Interior	a. Check blackout panels, ventilation fan, power distribution panel, electrical receptacles, and switches for obvious signs of damage. b. Stow ladder (para 2-30b).	

Table 2-4. Preventive Maintenance Checks and Services (M1079) (Cont)

Item No.	Interval	Location	<u>Crewmember</u> Procedure	Not Fully Mission Capable If:
		Item to Check/ Service		
 <p>The diagram shows a top-down view of an aircraft cabin interior. Labels with arrows point to various lighting components: 'BLACKOUT LIGHTS' at the top edge, 'INTERIOR LIGHTS' on the side panels, 'EMERGENCY LIGHTS' on the side walls, 'LIGHT SWITCH' on the side panel, and 'BLACKOUT OVERRIDE SWITCH' on the side panel. The cockpit area is visible at the bottom of the diagram.</p>				
7	During	Interior Lights	<p>a. Position INTERIOR LIGHTS switch to ON then OFF and verify four interior lights illuminate.</p> <p>b. Position INTERIOR LIGHTS switch to ON then OFF and verify two blackout lights and four emergency lights illuminate (para 2-34).</p>	

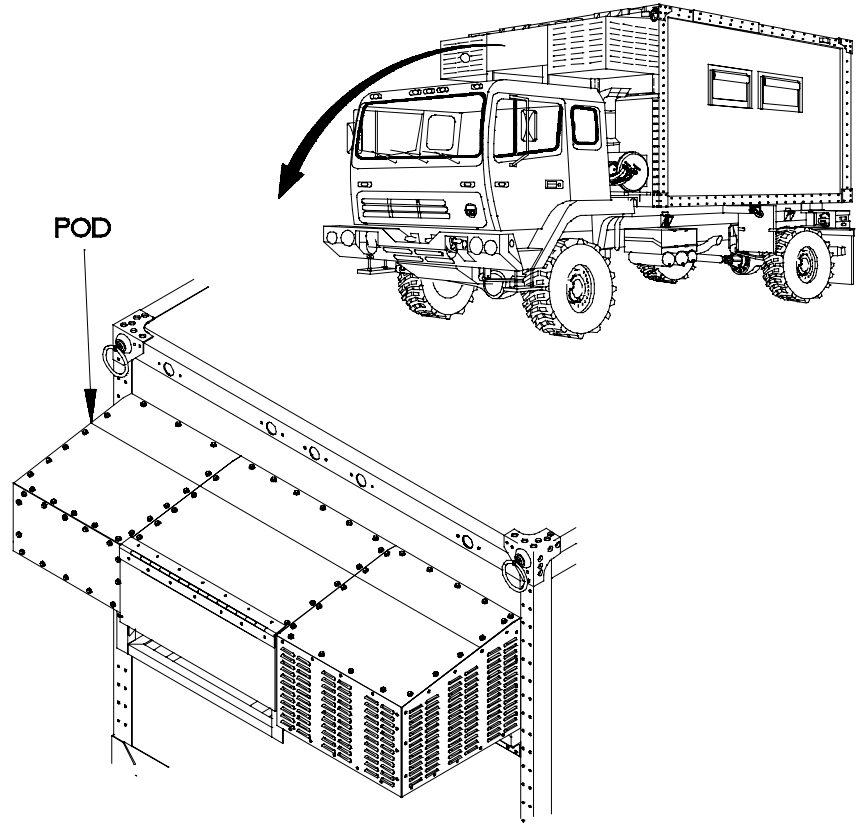
1B18A081

Table 2-4. Preventive Maintenance Checks and Services (M1079) (Cont)

Item No.	Interval	Location	Crewmember Procedure	Not Fully Mission Capable If:
		Item to Check/ Service		
8	During	Fan	<p>a. Position fan switch ON and then OFF and verify fan operates properly (para 2-35).</p> <p>b. Position main light switch to OFF (para 2-21c).</p>	
9	Weekly	Power Panel Receptacles	Check 110/208 vac power panel receptacles for damage.	Power panel receptacle(s) is damaged.

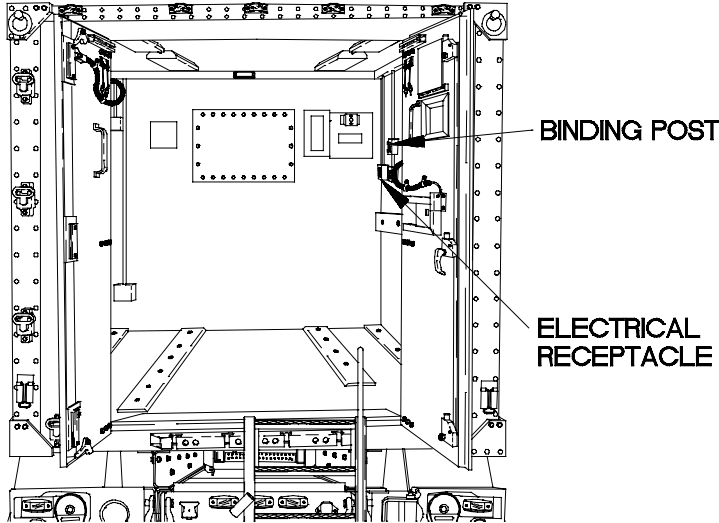
Table 2-4. Preventive Maintenance Checks and Services (M1079) (Cont)

Item No.	Interval	Location	Crewmember Procedure	Not Fully Mission Capable If:
		Item to Check/ Service		
10	Weekly	Pod	Check pod for obvious signs of damage.	Pod is damaged.



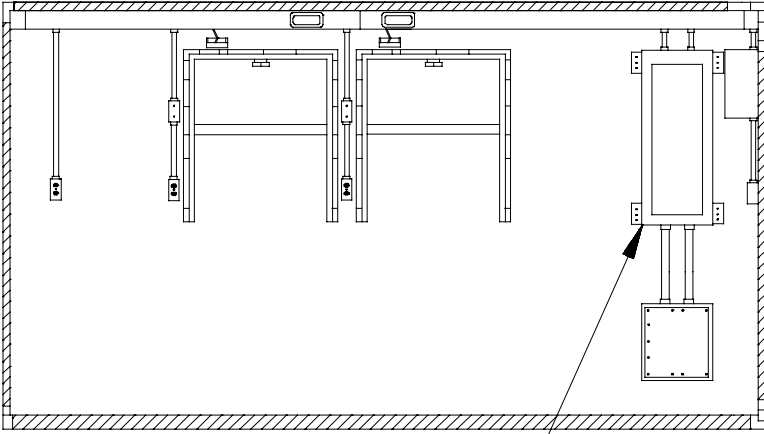
1B18A111

Table 2-4. Preventive Maintenance Checks and Services (M1079) (Cont)

Item No.	Interval	Location	Crewmember Procedure	Not Fully Mission Capable If:
		Item to Check/ Service		
				
11	Weekly	Electrical Receptacles and Binding Posts	<p>a. Lower ladder (para 2-30a).</p> <p>b. Check six electrical receptacles and binding posts for obvious signs of damage.</p>	<p>b. Three or more electrical receptacles or one or more binding posts are damaged.</p>

1B18A121

Table 2-4. Preventive Maintenance Checks and Services (M1079) (Cont)

Item No.	Interval	Location	Crewmember Procedure	Not Fully Mission Capable If:
		Item to Check/ Service		
 <p>110/208 VAC POWER DISTRIBUTION PANEL</p> <p>1B18A131</p>				
12	Weekly	110/208 VAC POWER DISTRIBUTION PANEL	<p>a. Check 110/208 VAC POWER DISTRIBUTION PANEL for obvious signs of damage.</p> <p>b. Stow ladder (para 2-30b).</p>	<p>a. 110/208 VAC POWER DISTRIBUTION PANEL is damaged to extent that shock hazard is present.</p>

Section III. OPERATION UNDER USUAL CONDITIONS

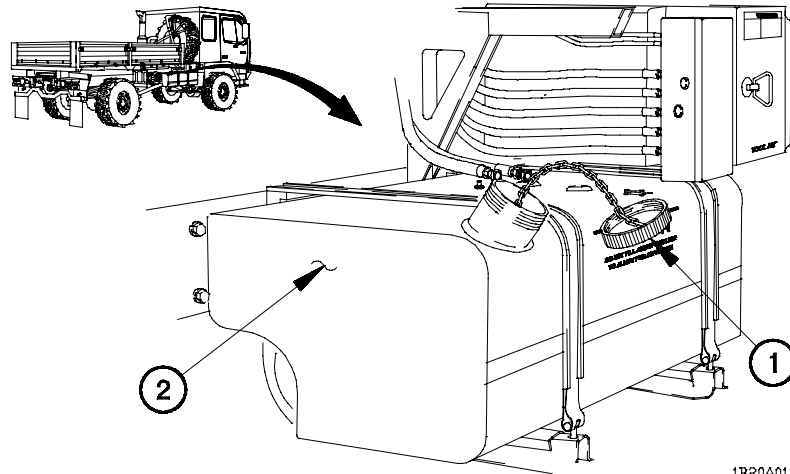
2-19. M1079 VAN PREPARATION FOR MOVEMENT

WARNING

- Heavy objects/loads, such as tool boxes and heavy parts, must always be carried on the floor with the weight distributed as equally as possible between left and right sides of M1079 van. Failure to comply decreases the stability of the M1079 van and will increase the likelihood of a rollover.
 - Heavy cabinets must always be mounted as low as possible with the weight distributed as equally as possible between left and right sides of M1079 van. Remember to consider the weight of the items that will be stored in the cabinets. Failure to comply decreases the stability of the M1079 van and will increase the likelihood of a rollover.
 - Always keep in mind, when placing items inside the M1079 van, that heavier items must always be positioned as low as possible and the weight distributed as equally as possible between left and right sides of M1079 van. Failure to comply decreases the stability of the M1079 van and will increase the likelihood of a rollover.
- (1) All objects that can shift during movement will be secured by using a bracing, cushioning, or tie-down method. The method used will be performed in a manner that will not cause damage to the walls or equipment.
 - (2) Verify that all workbenches, lockers, cabinets, and shelves are securely attached to walls and floor.
 - (3) Close van windows (para 2-33b).
 - (4) Disconnect van 12/24 vdc power (para 2-38b).
 - (5) Disconnect van AC power (para 2-32b).
 - (6) Close van doors (para 2-31b or d).
 - (7) Stow van ladder (para 2-30b).

2-20. PREPARATION FOR USE

a. Fueling Vehicle.



- (1) Remove fuel cap (1) from fuel tank (2).

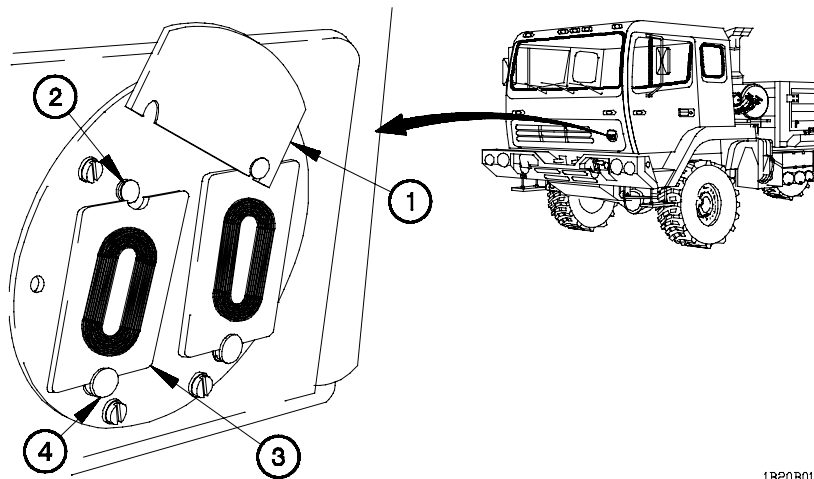
WARNING

Diesel fuel is flammable. Do not fill fuel tank with engine running, while smoking, or when near an open flame. Never overfill the tank or spill fuel. If fuel is spilled, clean it up immediately. Failure to comply may result in serious injury or death to personnel.

- (2) Fill fuel tank (2) with fuel.
 (3) Install fuel cap (1) on fuel tank (2).

2-20. PREPARATION FOR USE (CONT)

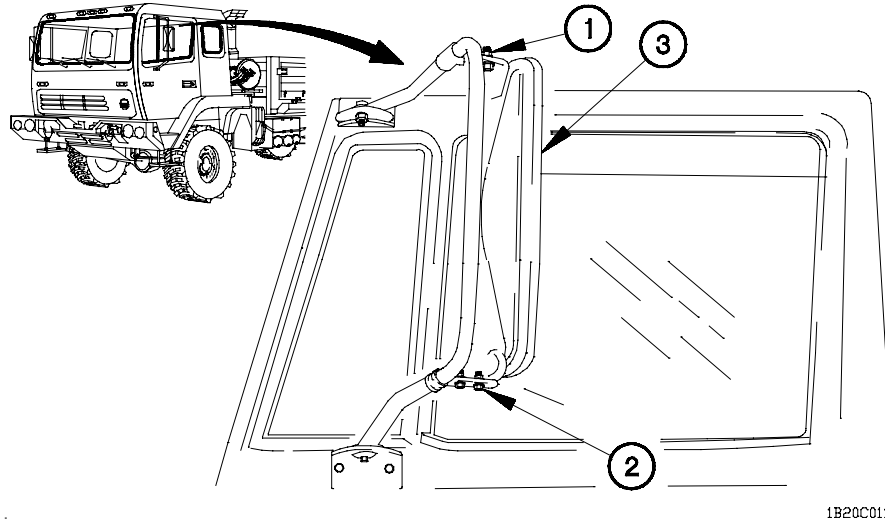
b. Changing Bridge Classification Numbers.



1B20B011

- (1) Press in bottom of lockplate (1).
- (2) Push lockplate (1) up and off one top lockpin (2).
- (3) Remove number plate (3) from top and bottom lockpins (2 and 4).
- (4) Place correct number on top of number plates (3).
- (5) Install number plate (3) on top and bottom lockpins (2 and 4).
- (6) Perform steps (1) through (5) for remaining number plates.
- (7) Press in on bottom of lockplate (1).
- (8) Slide lockplate (1) on two top lockpins (2).

c. Adjusting Mirrors.



CAUTION

Do not attempt to move mirror support. Only mirror is adjustable. Failure to comply may result in damage to equipment.

NOTE

Left and right mirrors are adjusted the same way. Left mirror shown.

- (1) Loosen nuts (1 and 2) on mirror (3).
- (2) Adjust mirror (3) to desired position.

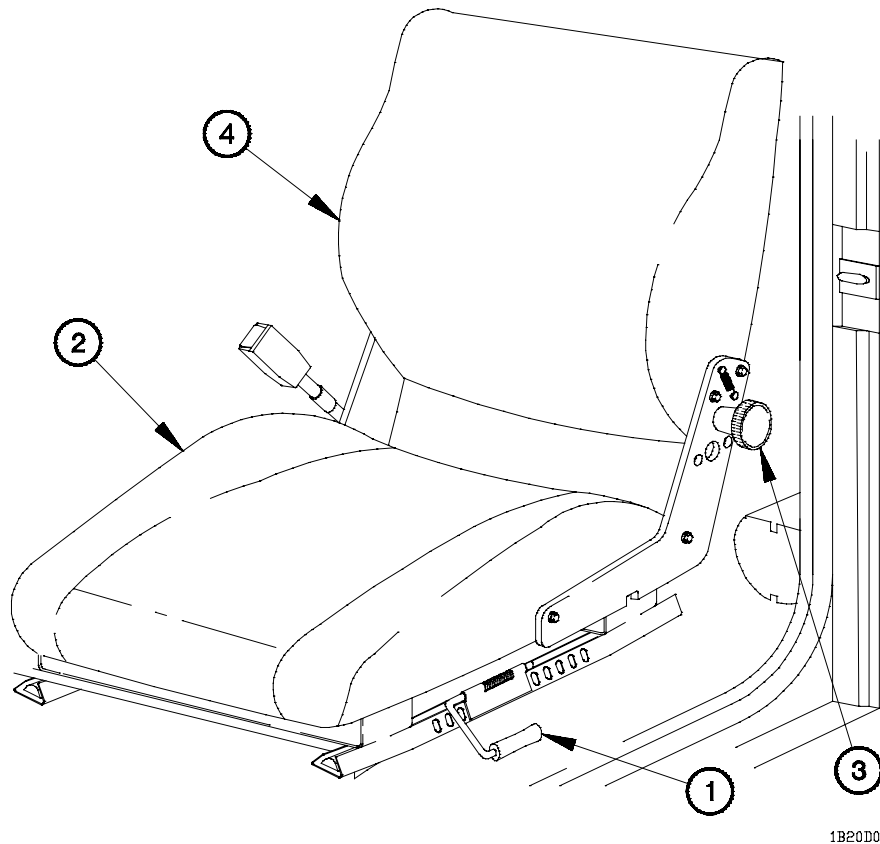
NOTE

Notify Unit Maintenance to tighten nuts to 53-71 lb-in. (6-8 N-m).

- (3) Tighten nuts (1 and 2).

2-20. PREPARATION FOR USE (CONT)

d. Adjusting Driver's Seat.



1B20D011

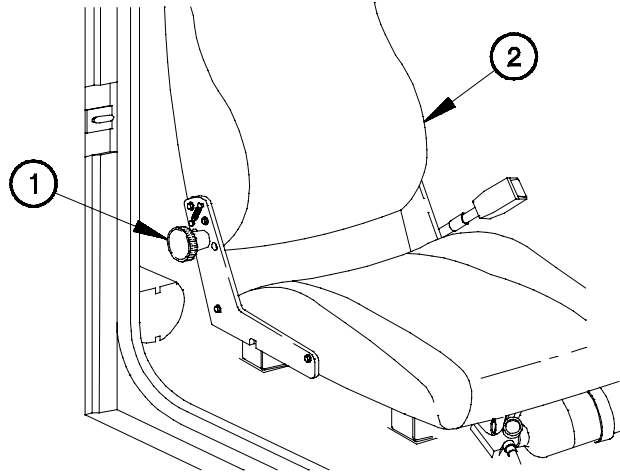
(1) Driver's Seat Adjustment.

- (a) Pull lever (1) outward (towards door) and slide seat (2) forward or backward.
- (b) Release lever (1) to lock seat (2) in place.

(2) Driver's Seat Fold Down.

- (a) Turn knob (3) to release latch on seat back (4).
- (b) Fold seat back (4) forward and release knob (3).

e. Adjusting Right Passenger Seat.

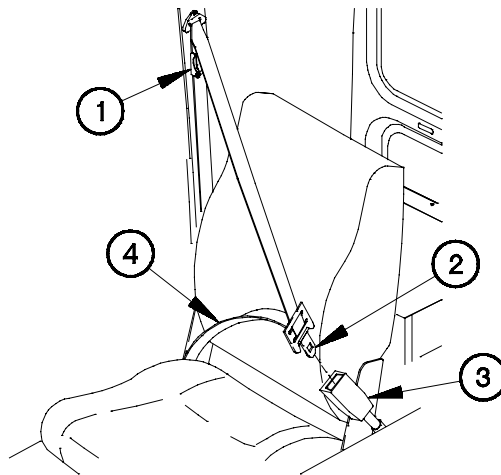


1B20E011

Passenger Seat Fold Down.

- (a) Turn knob (1) to release latch on seat back (2).
- (b) Fold seat back (2) forward and release knob (1).

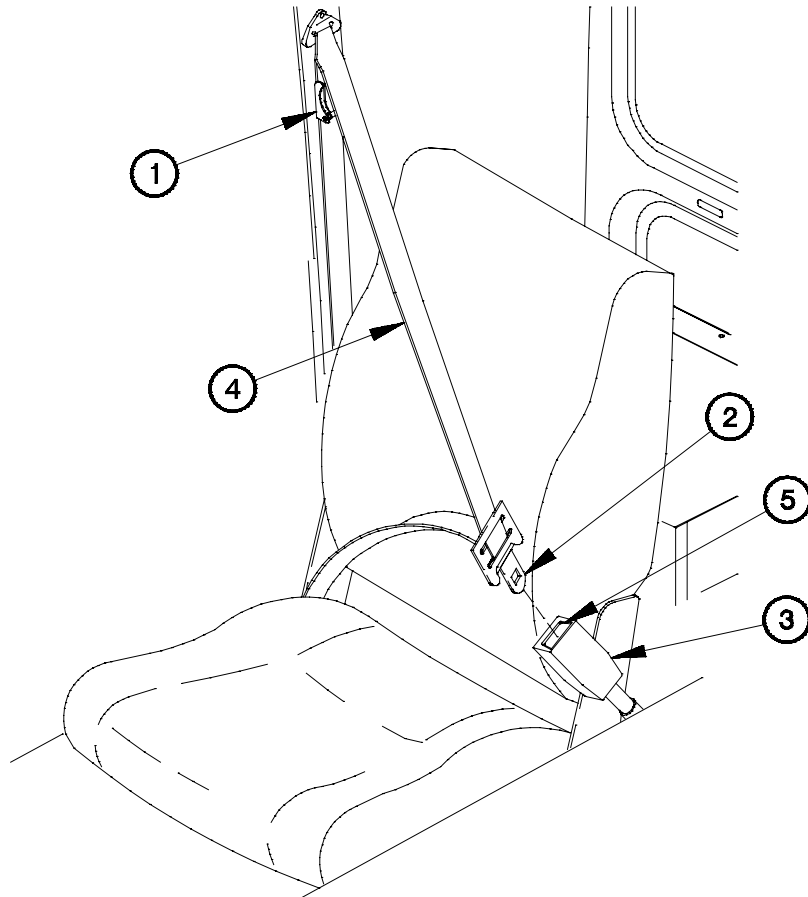
f. Operating Seat Belt.



1B20F011

- (1) Unlock comfort latch (1).
- (2) Insert seat belt flat metal end (2) in buckle (3) until click is heard.
- (3) Position seat belt (4) as low as possible across hips.

2-20. PREPARATION FOR USE (CONT)



1B20F021

WARNING

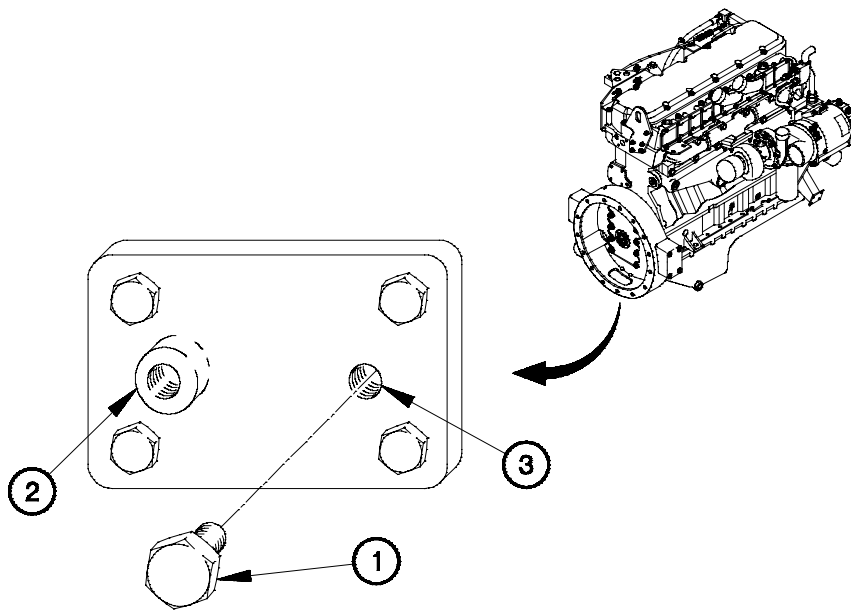
Do not pull seat belt more than 1 in. (25 mm) away from shoulder. Seat belt will not be effective if accident occurs. Failure to comply may result in serious injury or death to personnel.

- (4) Adjust seat belt (4) away from shoulder and lock comfort latch (1).
- (5) Push button (5) on buckle (3) and pull out seat belt flat metal end (2) to release seat belt (4).

g. Installing Flywheel Housing Vent Plug.

CAUTION

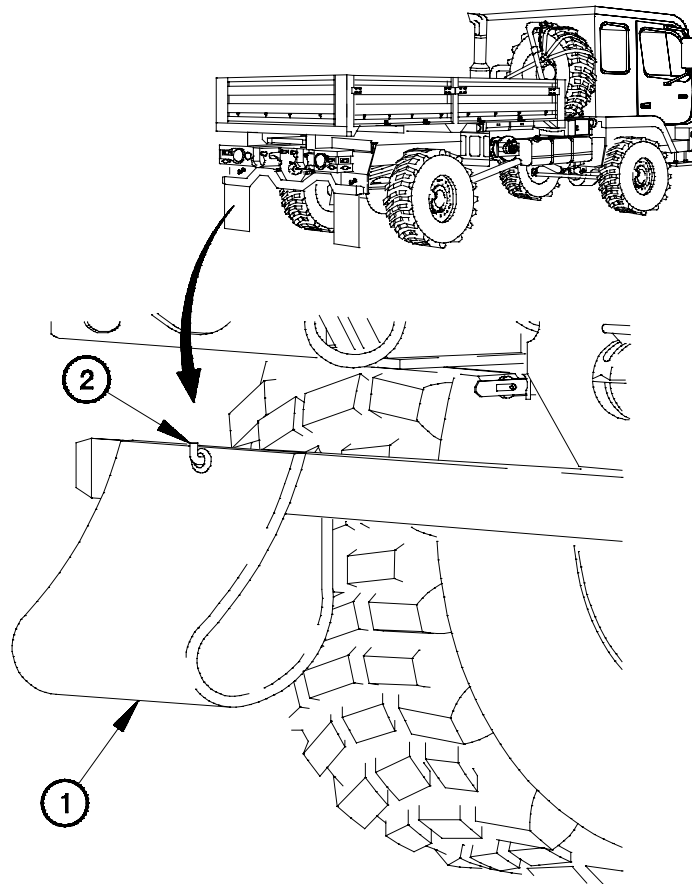
If vehicle will be operating in water 30 in. (762 mm) or of unknown depth, flywheel housing vent plug must be installed. Failure to comply may result in damage to equipment.



1B20G01B

- (1) Remove flywheel housing vent plug (1) from stowage mount (2).
- (2) Install flywheel housing vent plug (1) in flywheel vent hole (3).

h. Operation in Off-Road Condition.



1B20H01B

CAUTION

Before driving off-road, raise and hook rear mudflaps. Failure to comply may result in damage to equipment.

Attach two mudflaps (1) on two hooks (2).

2-21. VEHICLE OPERATION

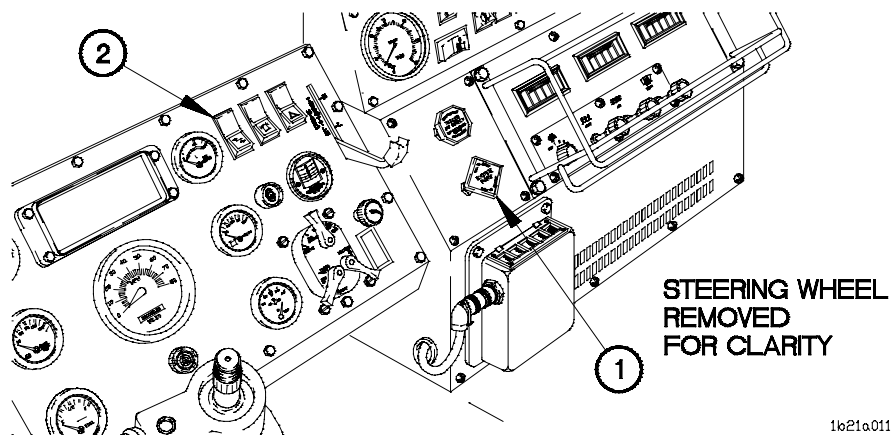
CAUTION

Cold weather radiator cover will be installed if temperatures are consistently below 40° F (4° C). It should be removed if temperatures are above 40° F (4° C), and must be removed if temperatures reach 70° F (21° C). Failure to comply may result in damage to equipment.

NOTE

If cold weather radiator cover has not been installed or needs to be removed, Notify Unit Maintenance.

a. Cold Engine Start.

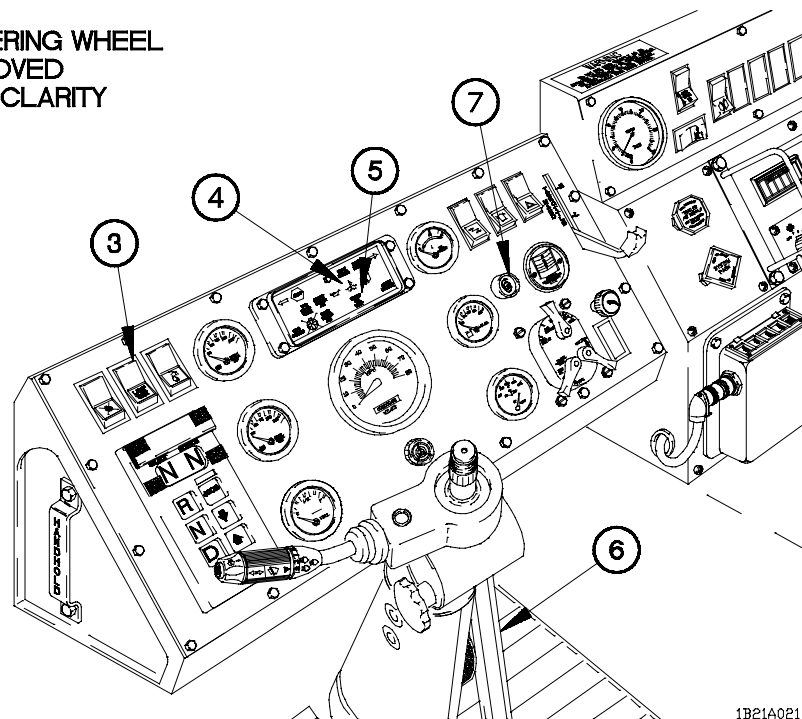


NOTE

If outside temperature is expected to remain below 40°F (4°C), notify Unit Maintenance to install the cold weather radiator cover.

- (1) Pull out SYSTEM PARK control (1).
- (2) Position master power switch (2) to on.

STEERING WHEEL
REMOVED
FOR CLARITY



1B21A021

NOTE

Vehicles with the following serial numbers are not equipped with Lamp Test Switch: 0002 through 0017, 0019 through 0025, 0027 through 0031, 0033 through 0038, 0040 and 0041, 0043 through 0053, 0055 through 0089, 0091 through 0254, 0256 through 0258, 0260 and 0261, 0263 through 2400, and 2402 through 3091.

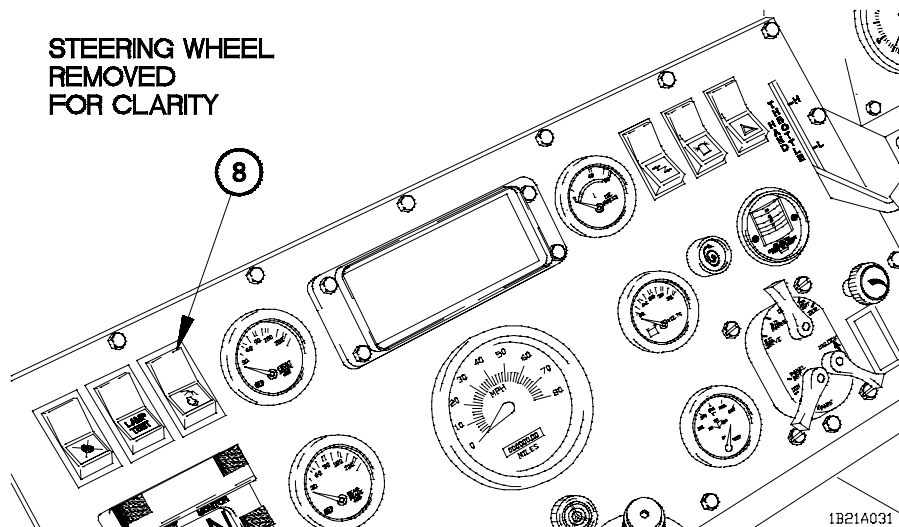
- (3) Press LAMP TEST switch (3) to verify that high engine temperature (4) and TRANS OIL TEMP (5) indicators illuminate.
- (4) Press down accelerator pedal (6) fully, then release it.
- (5) Press down and hold accelerator pedal (6) at approximately 1/3 of travel.

CAUTION

Do not engage starter pushbutton for more than 30 seconds. If engine fails to start within this period, release starter pushbutton and wait two minutes before attempting to start engine again. Failure to comply may result in damage to equipment.

- (6) Press and hold starter pushbutton (7).

2-21. VEHICLE OPERATION (CONT)

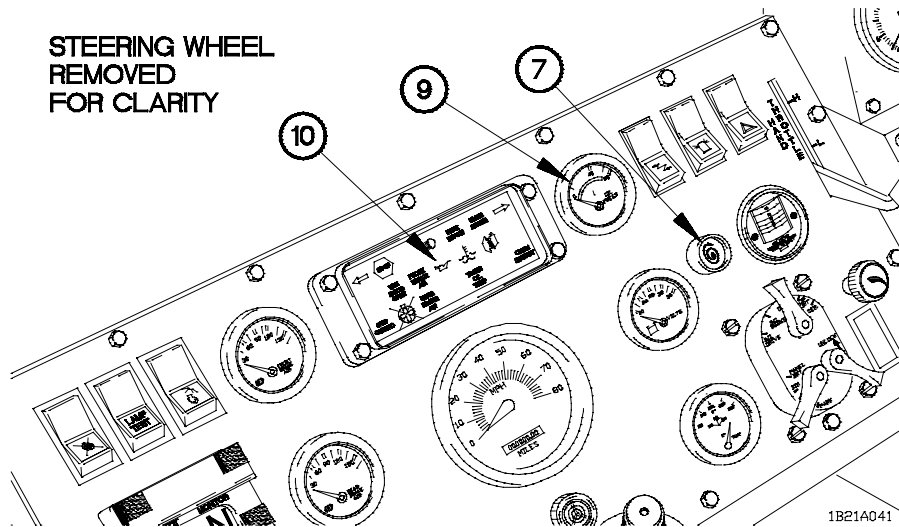


CAUTION

- • Do not press ether start switch unless engine is cranking. Failure to comply may result in damage to engine.
- Do not use ether after the engine has reached idle speed (750 rpm) and is no longer in danger of stalling. Failure to comply may result in damage to engine.

NOTE

- Continue to inject ether if engine has started but will not run without ether.
-
- If outside air temperature is 32° F to -25° F (0° C to -32° C) perform step (6) and (7).
- (7) Press and hold ether start switch (8) for approximately three seconds and release for two seconds.
- (8) Repeat step (7) until engine has started, engine speed has increased over cranking speed, and engine maintains speed.



- (9) Release starter pushbutton (7) when engine starts or after 30 seconds.

CAUTION

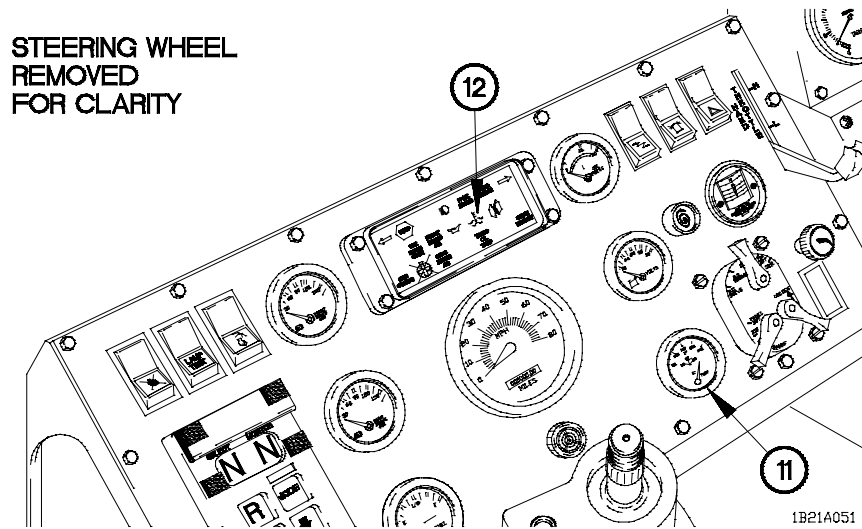
- If STOP indicator illuminates (red) to warn Operator when a potential engine failure (e.g., low oil pressure, low coolant, coolant overheating, etc.) has occurred, shut down engine immediately (para 2-21f) and perform Engine System Troubleshooting (para 3-3). Failure to comply may result in damage to equipment.
- If OIL PRESS gage does not show engine oil pressure of 15-80 psi (103-552 kPa) within 10-15 seconds after starting engine, shut down engine immediately (para 2-21f) and perform Engine System Troubleshooting (para 3-3). Failure to comply may result in damage to equipment.

NOTE

Oil pressure will increase when engine speed increases and will decrease when engine speed decreases.

- (10) Check that OIL PRESS gage (9) reads between 15-80 psi (103-552 kPa). If OIL PRESS gage reads in red zone and engine oil pressure indicator (10) is illuminated, shut down engine (para 2-21f) and perform Engine System Troubleshooting (para 3-3).

2-21. VEHICLE OPERATION (CONT)



NOTE

- Water Temperature must be a minimum of 100° F (38° C) in order to drive vehicle. Engine will warm up to normal operating temperature of 165° F (74° C) more quickly if engine is under a load condition such as driving.

- Vehicle performance, including heater/defroster, will be reduced when engine operating temperature is between 100°F to 165°F (38°C to 74°C). Avoid conditions requiring maximum performance until engine reaches 165° F (74° C).

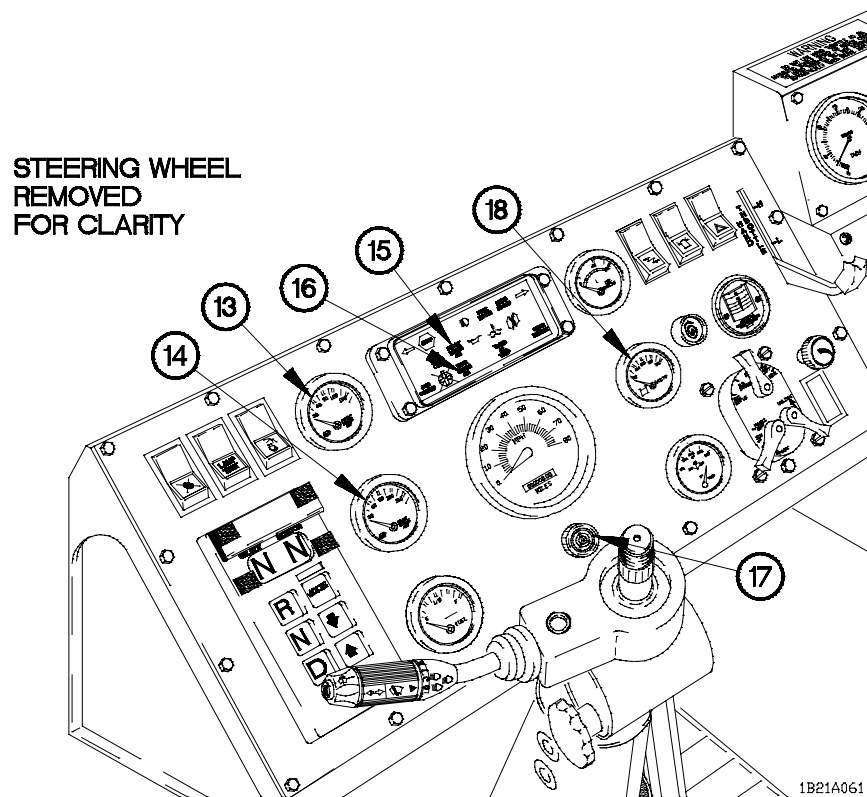
- (11) Operate engine at idle (750 rpm) to warm-up engine until WATER TEMP gage (11) reaches a minimum of 100° F (38° C) to begin driving or normal operating temperature of 165° F (74° C).

NOTE

Perform step (12) in outside temperatures of 32°F to -25°F (0°C to - 32°C), if extreme or unusual conditions exist such as heavy windshield frost or when it is difficult to achieve normal operating temperature of 165° F (74° C).

- (12) Perform Rapid Engine Warm-Up (para 2-59).

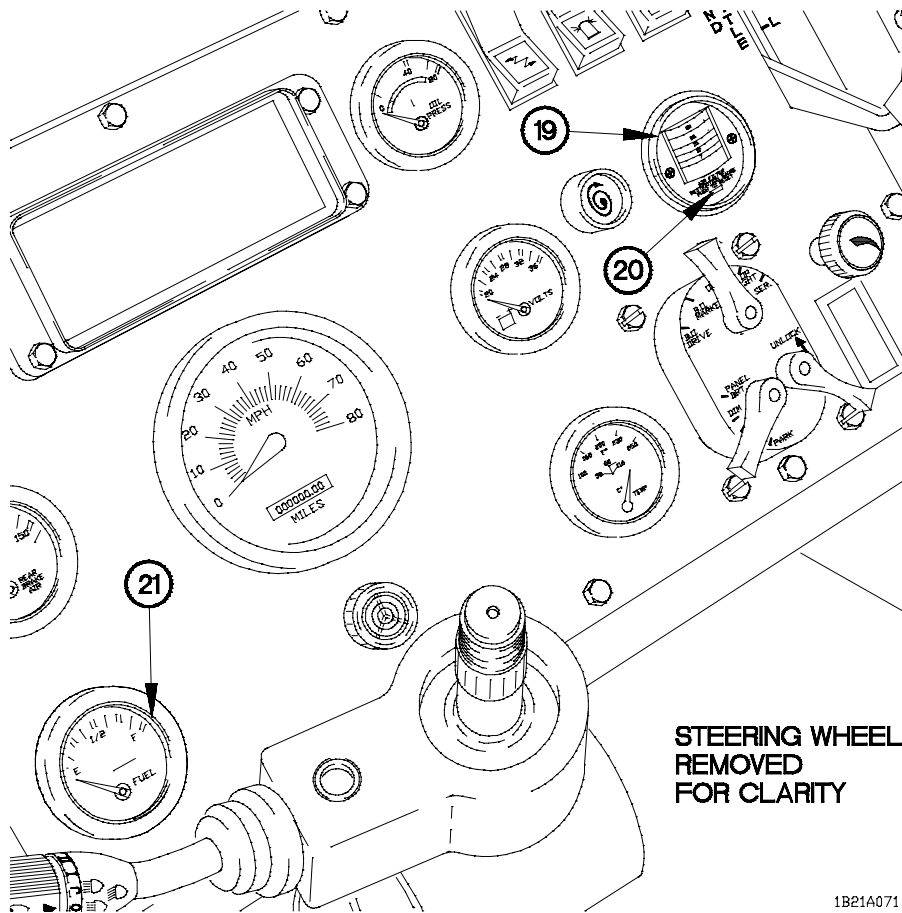
- (13) Check that WATER TEMP gage (11) reads between 100° F to 230° F (38° C to 110° C). If WATER TEMP gage reads in the red zone or high engine temperature indicator (12) is illuminated, shut down engine (para 2-21f) and perform Engine System Troubleshooting (para 3-3).



NOTE

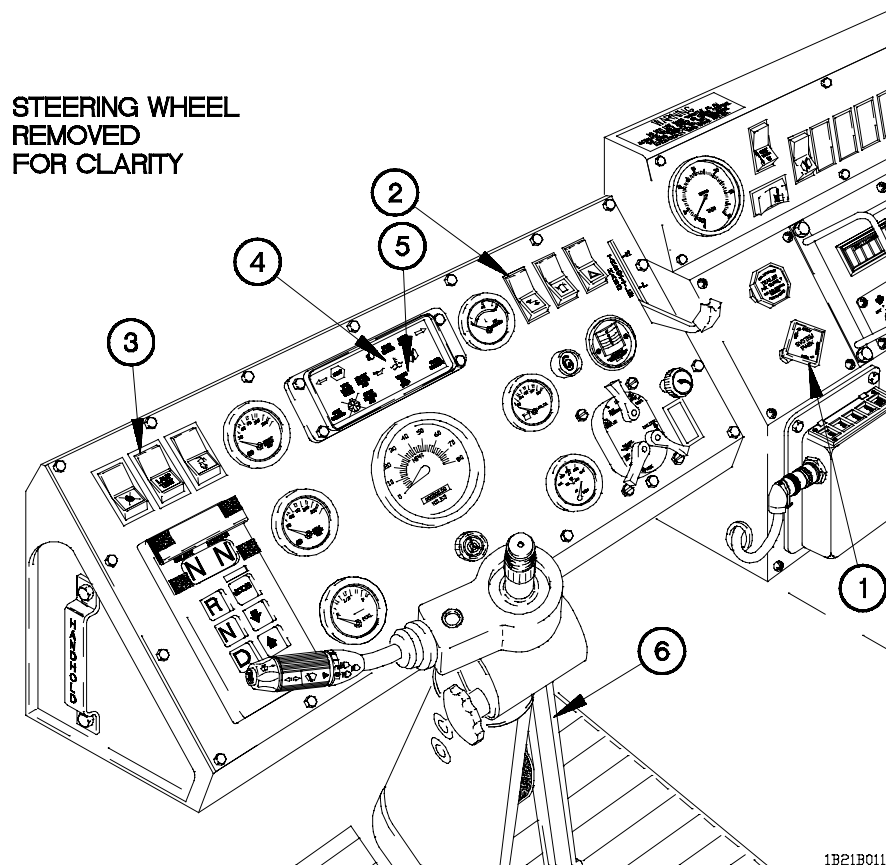
- If FRONT BRAKE AIR and REAR BRAKE AIR pressure gages do not read between 65-120 psi (448-827 kPa) after engine warm-up, shut down engine (para 2-21f) and perform Air System Troubleshooting (para 3-3). ■
 - FRONT BRAKE AIR and REAR BRAKE AIR indicators will illuminate (red) and audible alarm will sound until air pressure is approximately 65 psi (448 kPa).
- (14) Check that FRONT BRAKE AIR pressure gage (13) and REAR BRAKE AIR pressure gage (14) read between 65-120 psi (448-827 kPa). FRONT BRAKE AIR indicator (15) and REAR BRAKE AIR indicator (16) illuminate (red) and audible alarm (17) will sound until both gages reach approximately 65 psi (448 kPa). ■
- (15) Check that VOLTS gage (18) reads between 26 and 30 volts. ■

2-21. VEHICLE OPERATION (CONT)



- (16) Check that AIR FILTER RESTRICTION GAUGE (19) reads below 25 in.
 - (a) Press reset button (20) if AIR FILTER RESTRICTION GAUGE (19) reads greater than 25 in. (in red area).
 - (b) Shut down engine (para 2-21f) and service air filter (para 3-9) if AIR FILTER RESTRICTION GAUGE still reads greater than 25 in. (in red area).
- (17) Check that FUEL gage (21) shows sufficient fuel to accomplish mission.
- (18) Select desired transmission gear (para 2-21e).

b. Warm Engine Start.



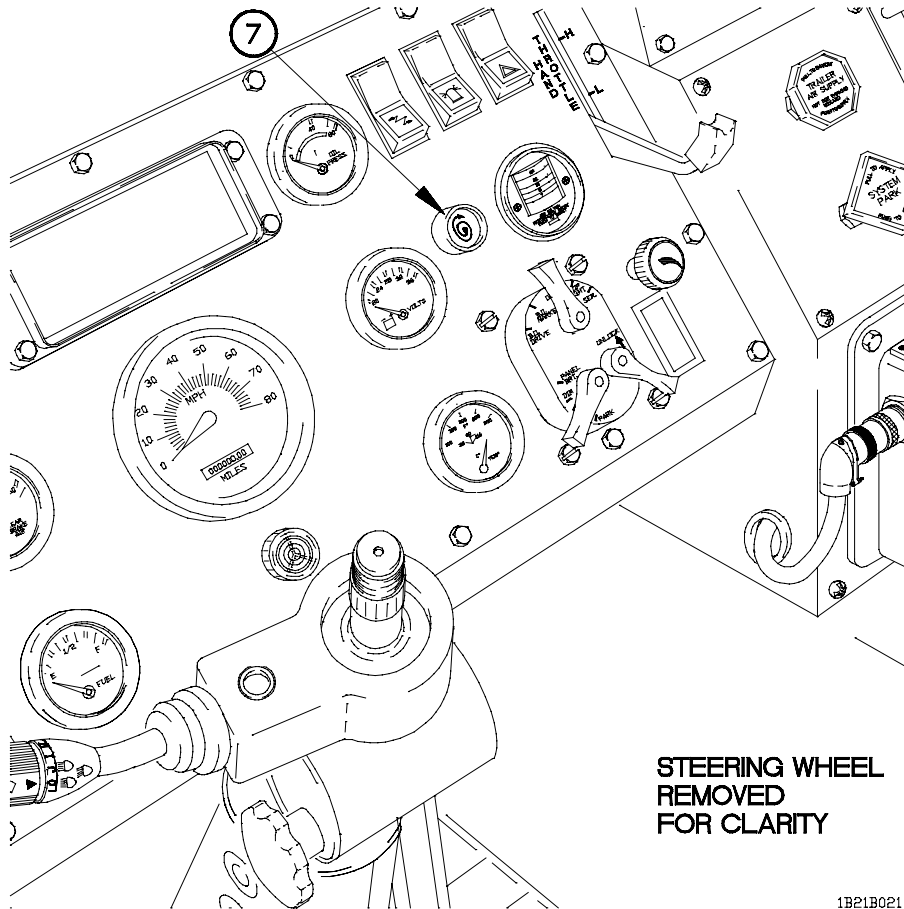
- (1) Pull out SYSTEM PARK control (1).
- (2) Position master power switch (2) to on.

NOTE

Vehicles with the following serial numbers are not equipped with Lamp Test Switch: 0002 through 0017, 0019 through 0025, 0027 through 0031, 0033 through 0038, 0040 and 0041, 0043 through 0053, 0055 through 0089, 0091 through 0254, 0256 through 0258, 0260 and 0261, 0263 through 2400, and 2402 through 3091.

- (3) Press LAMP TEST switch (3) to verify that high engine temperature (4) and TRANS OIL TEMP (5) indicators illuminate.
- (4) Press down accelerator pedal (6) fully, then release it.
- (5) Press down and hold accelerator pedal (6) at approximately 1/3 of travel.

2-21. VEHICLE OPERATION (CONT)

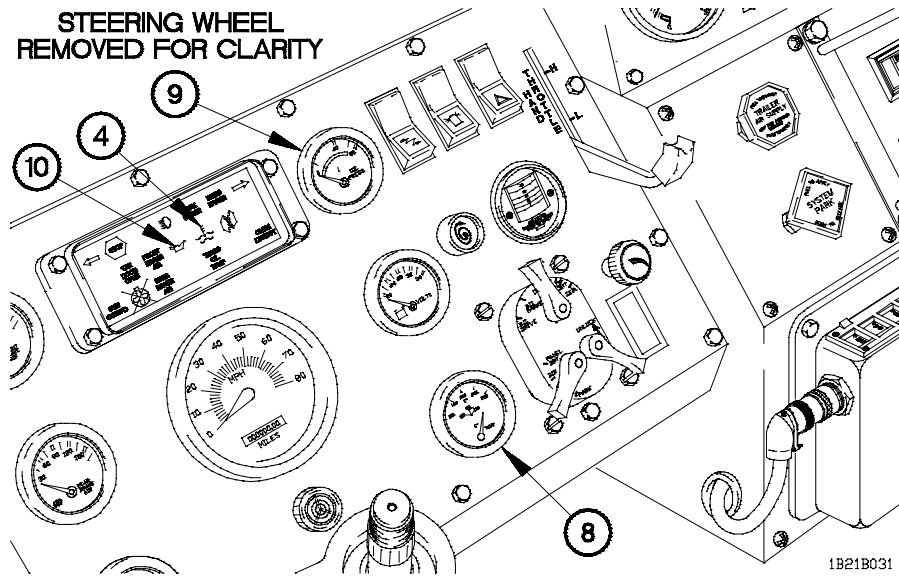


1B21B021

CAUTION

Do not engage starter pushbutton for more than 30 seconds. If engine fails to start within this period, release starter pushbutton and wait two minutes before attempting to start engine. Failure to comply may result in damage to equipment.

- (6) Press and hold starter pushbutton (7).
- (7) Release starter pushbutton (7) when engine starts.



CAUTION

- If STOP indicator illuminates (red) to warn Operator when a potential engine failure (e.g., low oil pressure, low coolant, coolant over-heating, etc.) has occurred, shut down engine immediately (para 2-21f) and perform Engine System Troubleshooting (para 3-3). Failure to comply may result in damage to equipment.
- If OIL PRESS gage does not show engine oil pressure of 15-80 psi (103-552 kPa) within 10-15 seconds after starting engine, shut down engine immediately (para 2-21f) and perform Engine System Troubleshooting (para 3-3). Failure to comply may result in damage to equipment.

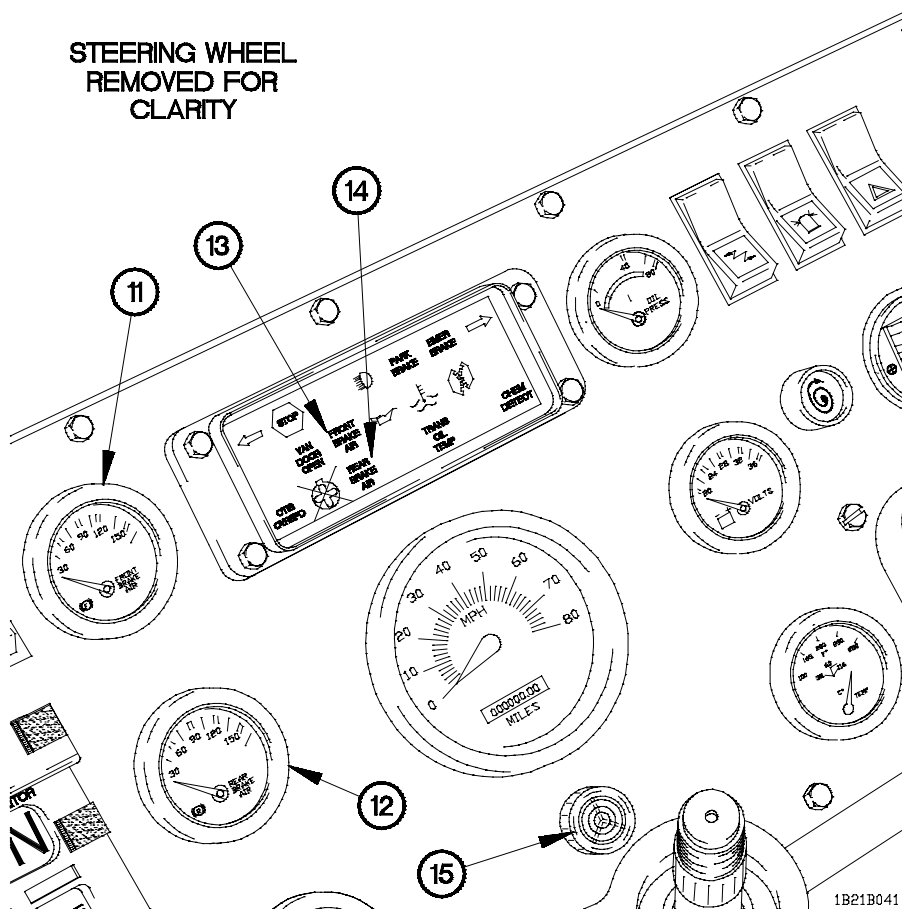
- (8) Check that WATER TEMP gage (8) reads between 100° F to 230° F (38° C to 110° C). If WATER TEMP gage reads in red zone and high engine temperature indicator (4) is illuminated, shut down engine (para 2-21f) and perform Engine System Troubleshooting (para 3-3).

NOTE

Oil pressure will increase when engine speed increases and will decrease when engine speed decreases.

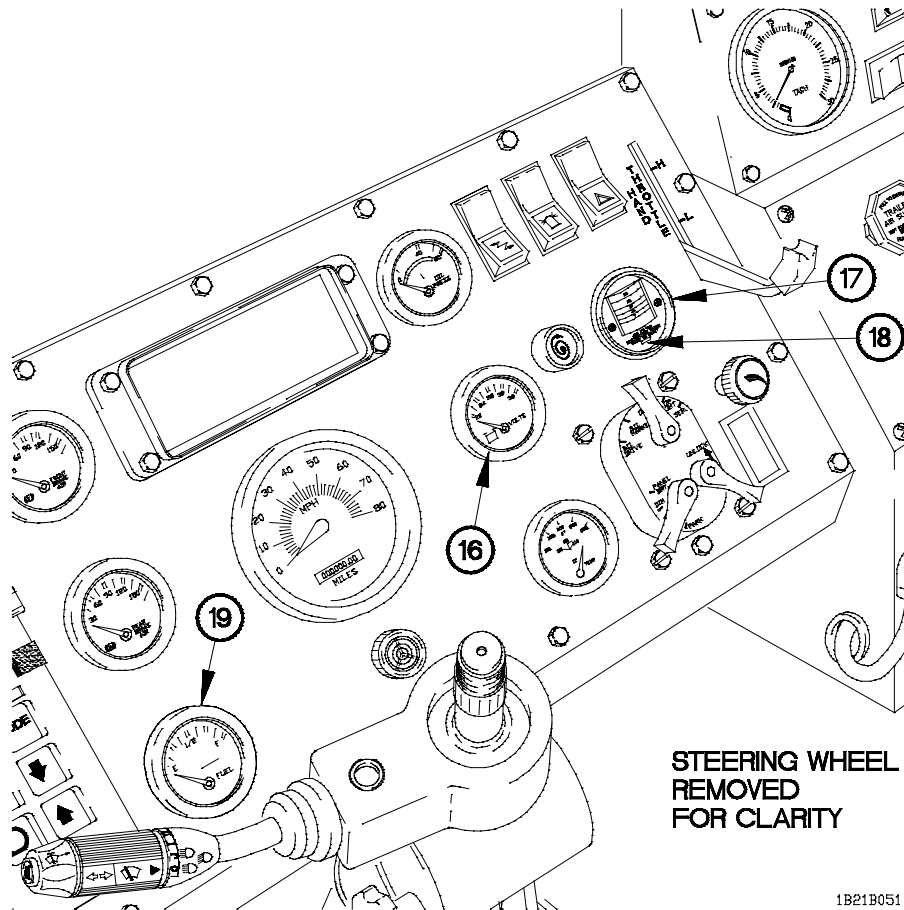
- (9) Check that OIL PRESS gage (9) reads between 15-80 psi (103-552 kPa). If OIL PRESS gage reads in red zone and engine oil pressure indicator (10) is illuminated, shut down engine (para 2-21f) and perform Engine Troubleshooting (para 3-3).

2-21. VEHICLE OPERATION (CONT)



NOTE

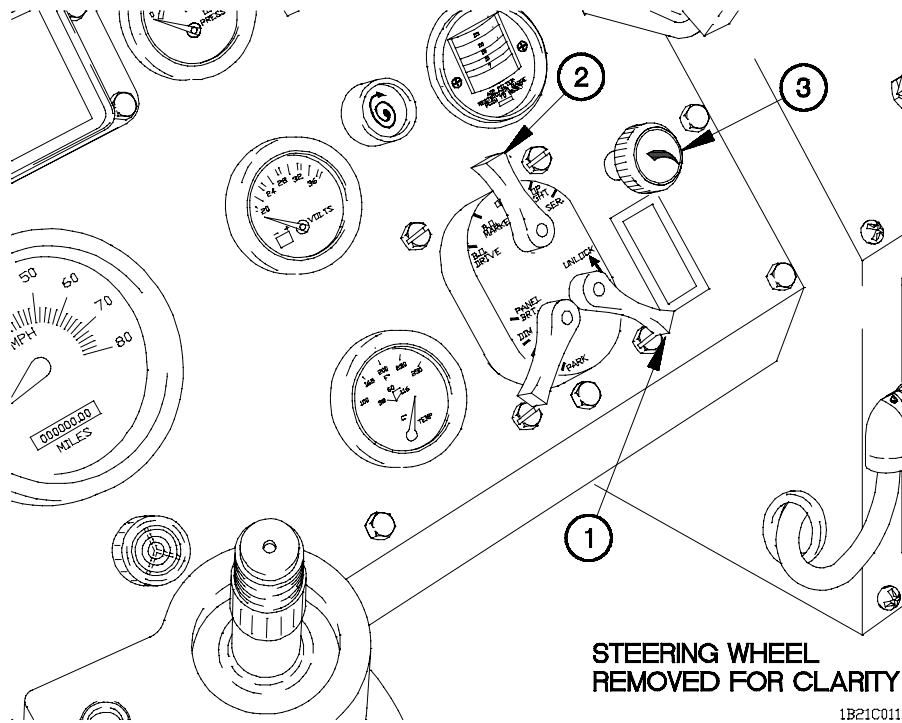
- • If FRONT BRAKE AIR and REAR BRAKE AIR pressure gages do not read between 65-120 psi (448-827 kPa) after engine warm-up, shut down engine (para 2-21f) and perform Air System Troubleshooting (para 3-3).
 - • FRONT BRAKE AIR and REAR BRAKE AIR indicators will illuminate (red) and audible alarm will sound until air pressure is approximately 65 psi (448 kPa).
- (10) Check that FRONT BRAKE AIR pressure gage (11) and REAR BRAKE AIR pressure gage (12) read between 65-120 psi (448-827 kPa). FRONT BRAKE AIR indicator (13) and REAR BRAKE AIR indicator (14) illuminate (red) and audible alarm (15) will sound until both gages reach approximately 65 psi (448 kPa).



- (11) Check that VOLTS gage (16) reads between 26 and 30 volts.
- (12) Check that AIR FILTER RESTRICTION GAUGE (17) reads below 25 in.
 - (a) Press reset button (18) if AIR FILTER RESTRICTION GAUGE (17) reads greater than 25 in. (in red area).
 - (b) Shut down engine (para 2-21f) and service air filter (para 3-9) if AIR FILTER RESTRICTION GAUGE still reads greater than 25 in. (in red area).
- (13) Check that FUEL gage (19) shows sufficient fuel for mission requirements.
- (14) Select desired transmission gear (para 2-21e).

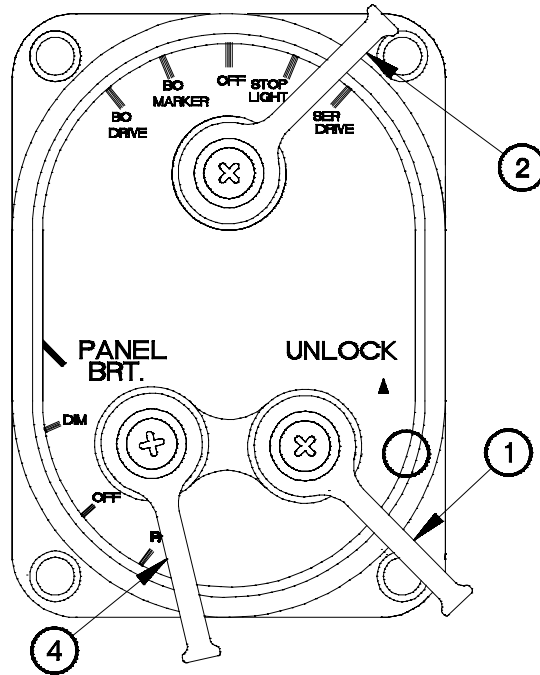
2-21. VEHICLE OPERATION (CONT)

c. Operating Vehicle Lights.



(1) Operate Instrument Panel Lights.

- (a) Lift up and hold UNLOCK lever (1).
- (b) Set main selector lever (2) to any position except OFF.
- (c) Release UNLOCK lever (1).
- (d) Turn dimmer switch (3) left to increase brightness or right to decrease brightness.
- (e) Set main selector lever (2) to OFF.



1B21C021

(2) Operate Parking Lights.

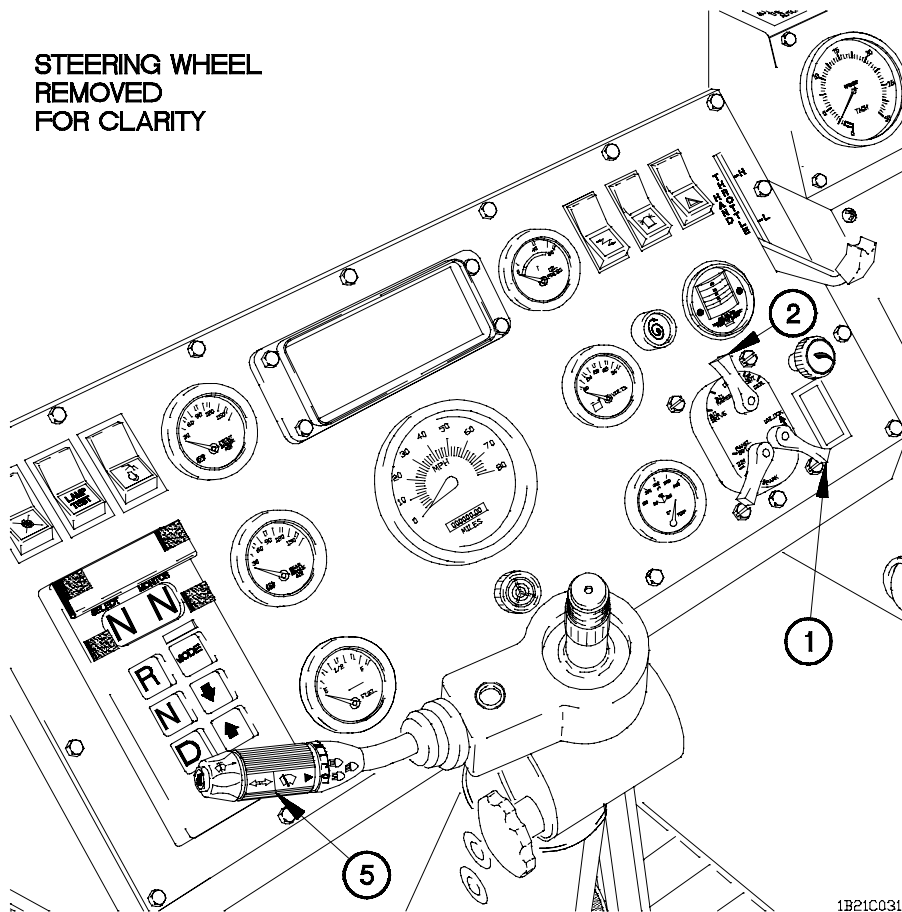
- (a) Lift up and hold UNLOCK lever (1).
- (b) Set main selector lever (2) to SER DRIVE.
- (c) Set auxiliary lever (4) to PARK.
- (d) Release UNLOCK lever (1).
- (e) Set auxiliary lever (4) to OFF to shut off only parking lights.
- (f) Set main selector lever (2) to OFF. All vehicle lights will go off.

(3) Operate Service Drive and Back-Up Lights.

- (a) Lift up and hold UNLOCK lever (1).
- (b) Set main selector lever (2) to SER DRIVE.
- (c) Release UNLOCK lever (1).

2-21. VEHICLE OPERATION (CONT)

STEERING WHEEL
REMOVED
FOR CLARITY



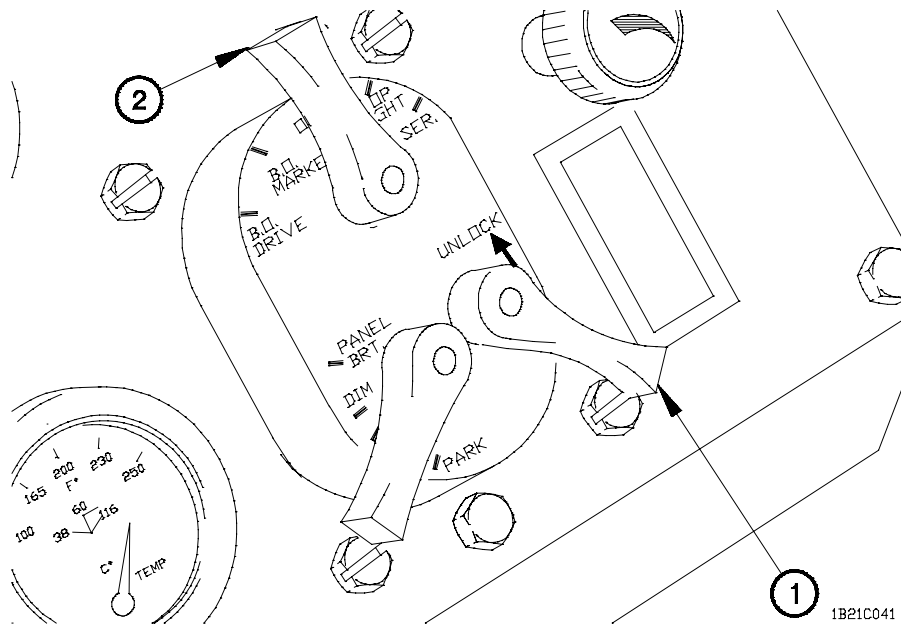
1B21C031

(3) Operate Service Drive Lights (Cont).

- (d) Pull headlight dimmer control (5) to operate headlights at high beam or low beam.
- (e) Set main selector lever (2) to OFF.

(4) Operate Stoplights.

- (a) Lift up and hold UNLOCK lever (1).
- (b) Set main selector lever (2) to STOP LIGHT.
- (c) Release UNLOCK lever (1).
- (d) Set main selector lever (2) to OFF.



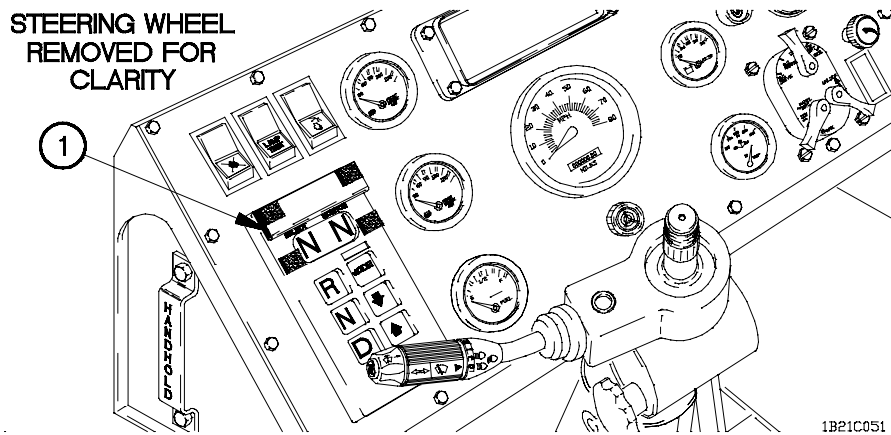
WARNING

Vehicle speed should be reduced to 5-10 mph (8-16 km/h) during blackout conditions. Failure to comply may result in serious injury or death to personnel.

- (5) Operate Blackout Drive Lights.
 - (a) Lift up and hold UNLOCK lever (1).
 - (b) Set main selector lever (2) to BO DRIVE.
 - (c) Release UNLOCK lever (1).
 - (d) Set main selector lever (2) to OFF.

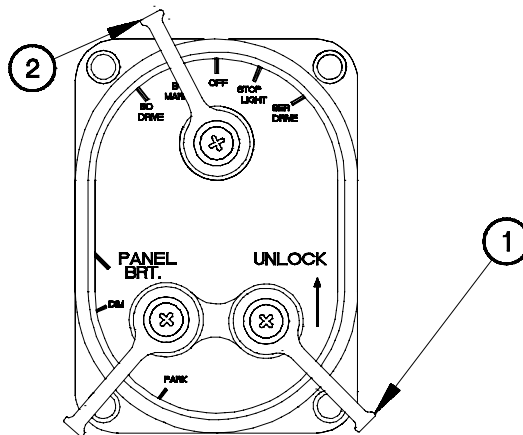
- (6) Operate Blackout Marker Lights.
 - (a) Set main selector lever (2) to BO MARKER.
 - (b) Set main selector lever (2) to OFF.

2-21. VEHICLE OPERATION (CONT)



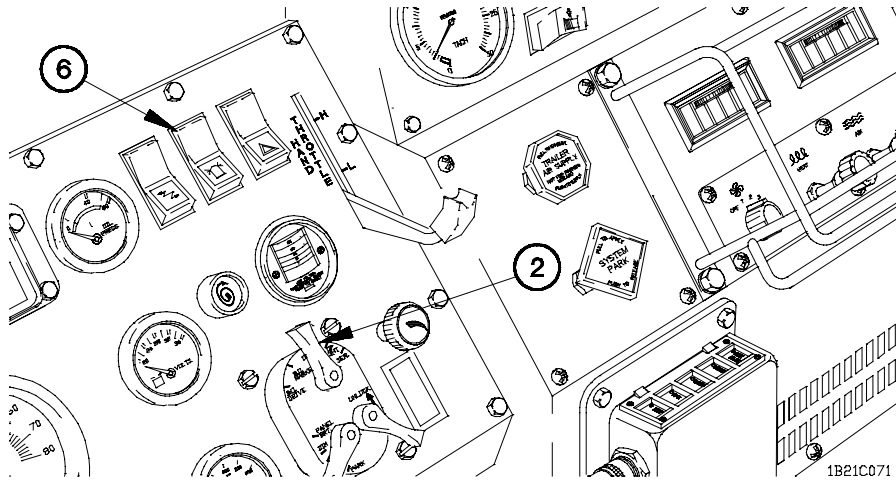
1B21C051

- (7) Operate WTEC II TEPSS Blackout Filter cover.
- (a) Lift blackout filter cover (1) from upper velcro.
 - (b) Lower blackout filter cover (1) and attach to lower velcro.



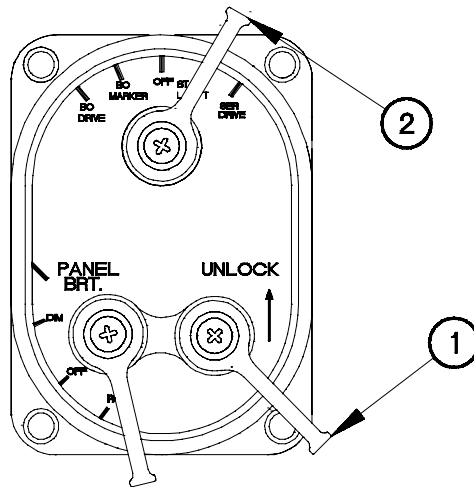
1B21C061

- (8) Operate Warning Light.
- (a) Install amber warning light (para 2-61a).
 - (b) Lift up and hold UNLOCK lever (1).
 - (c) Set main selector lever (2) to SER DRIVE or STOP LIGHT.
 - (d) Release UNLOCK lever (1).



(8) Operate Warning Light (Cont).

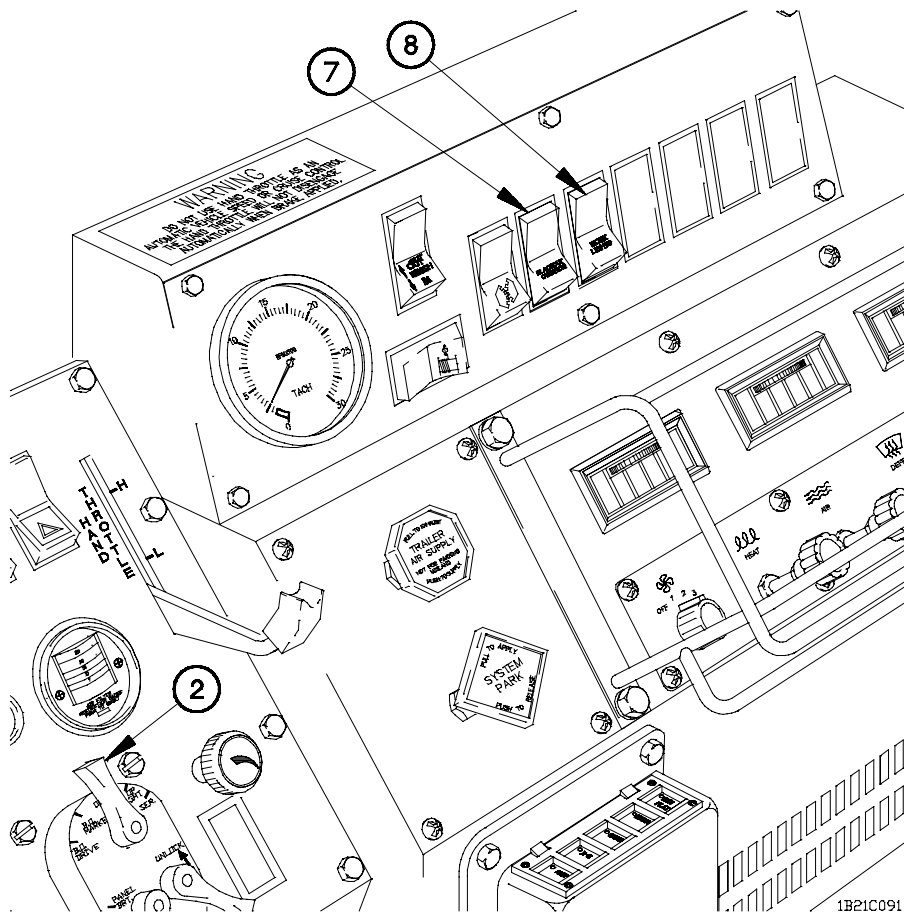
- (e) Position warning light switch (6) to on.
- (f) Position warning light switch (6) to off.
- (g) Set main selector lever (2) to OFF.



(9) Operate Work Lights.

- (a) Lift up and hold UNLOCK lever (1).
- (b) Set main selector lever (2) to any position except OFF.
- (c) Release UNLOCK lever (1).

2-21. VEHICLE OPERATION (CONT)



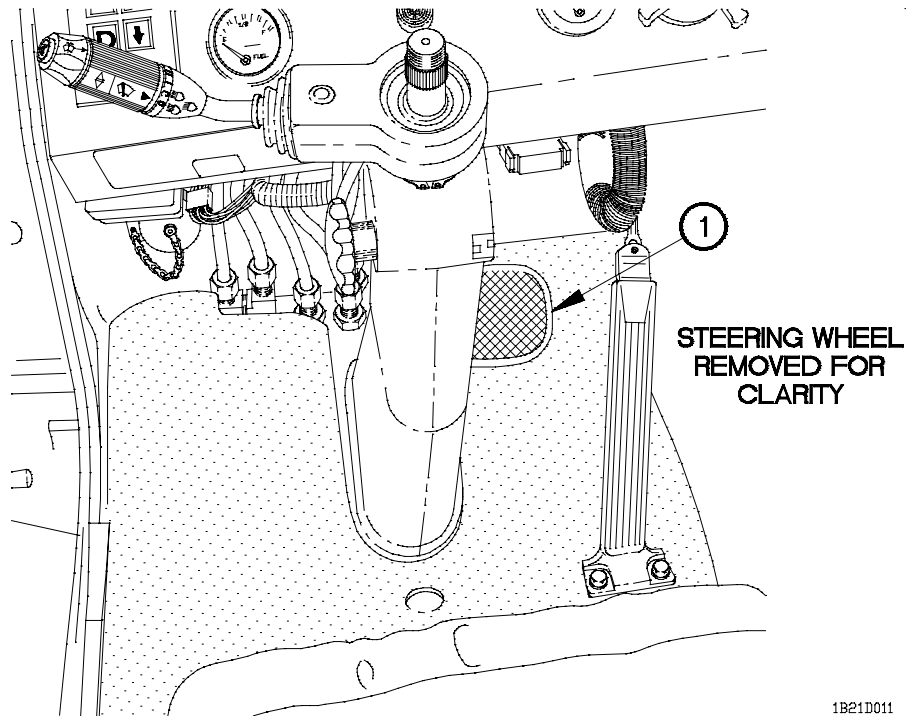
NOTE

Perform step (9d) only if main selector lever is positioned to BO DRIVE or BO MARKER.

(9) Operate Work Lights (Cont).

- (d) Position BLACKOUT OVERRIDE switch (7) to on.
- (e) Position work lights switch (8) to on.
- (f) Position work lights switch (8) to off.
- (g) Position BLACKOUT OVERRIDE switch (7) to off.
- (h) Set main selector lever (2) to OFF.

d. Operate Service Brakes.



WARNING

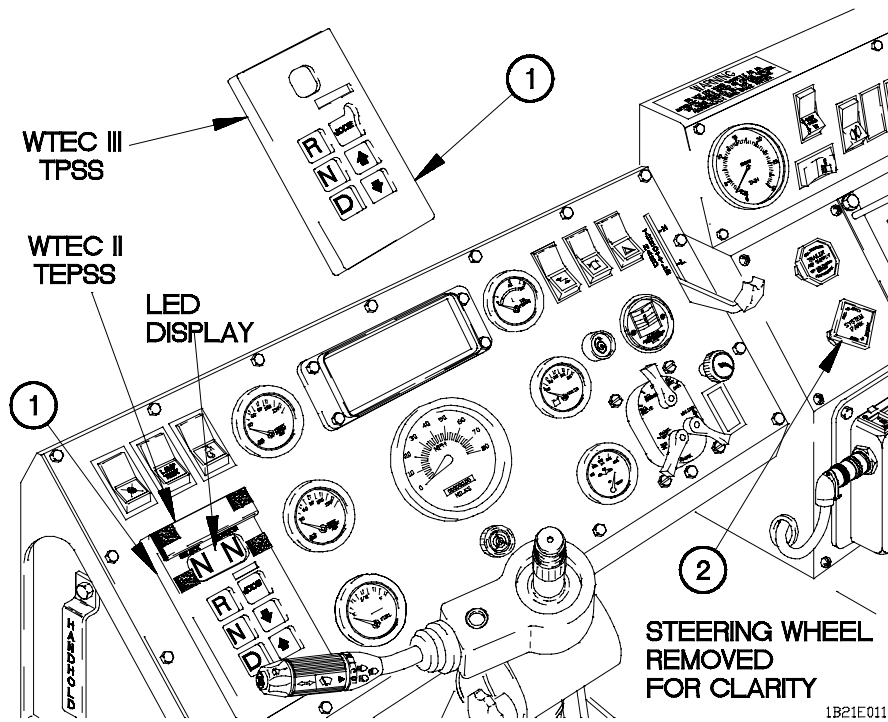
- Operating in water or mud causes brake linings to get wet and can impair vehicle braking. Dry brakes by driving vehicle about 500 ft (150 m) while applying service brakes often. If adequate braking is not restored by drying brakes, notify Unit Maintenance. Failure to comply may result in injury to personnel or damage to equipment.
- Do not press brake pedal hard three or four times in a row. Air supply will be used up and service brakes will not work until air pressure builds up again. Do not operate vehicle until FRONT and REAR BRAKE AIR pressure reaches at least 100 psi (690 kPa). Failure to comply may result in serious injury or death to personnel or damage to equipment. ■

Push down and hold brake pedal (1) to slow or stop vehicle.

e. Selecting Transmission Operating Range.

- (1) Start engine (para 2-21a or b).

2-21. VEHICLE OPERATION (CONT)



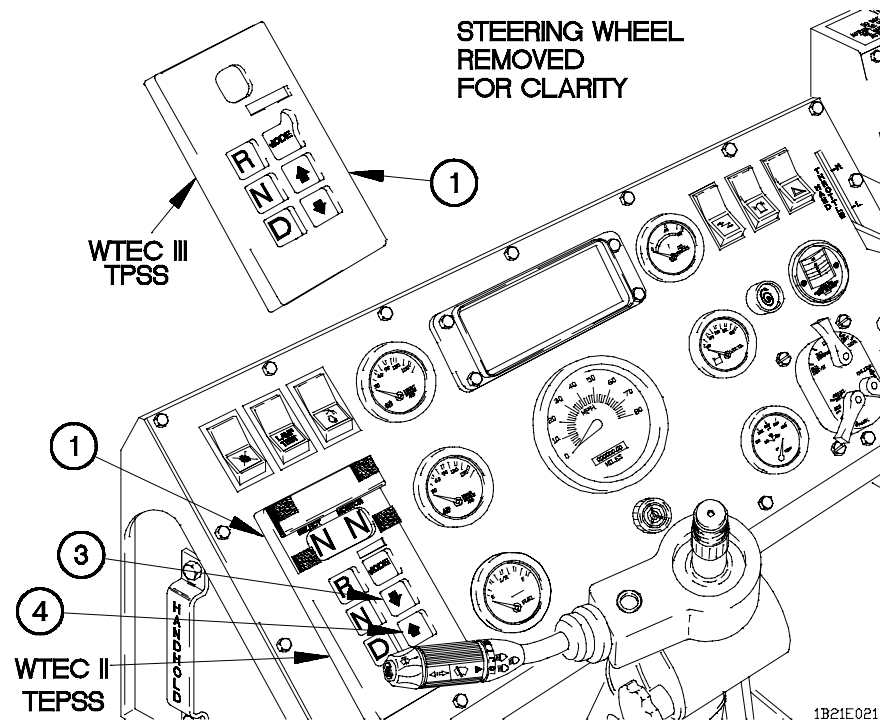
CAUTION

- Engine rpm must be at idle (750 rpm) prior to selecting any forward or reverse gear. Failure to comply may result in damage to equipment.
- Do not allow vehicle to coast in N (Neutral). Failure to comply may result in damage to equipment.

NOTE

When transmission is operating normally, left side of LED display will indicate selected gear and right side of LED display will indicate current operating gear.

- (2) Select desired travel direction (D for Drive or R for Reverse) on WTEC II TEPSS (1) or WTEC III TPSS (1).
- (3) Push in SYSTEM PARK control (2).

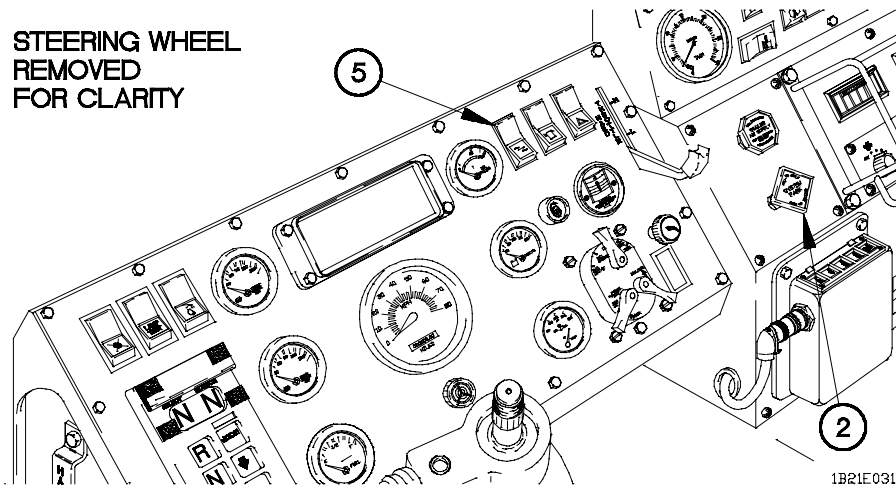


WARNING

Transmission incorporates a hold feature to prohibit upshifting above selected gear during normal driving. However, during downhill operation, transmission may upshift above selected gear. On downgrades, vehicle speed may need to be restricted by using service brakes. Failure to comply may result in serious injury or death to personnel or damage to equipment.

- (4) Press down arrow button (3) on WTEC II TEPSS (1) or WTEC III TPSS (1) to shift transmission to lower gear.
- (5) Press up arrow button (4) on WTEC II TEPSS (1) or WTEC III TPSS (1) to shift transmission to higher gear.

2-21. VEHICLE OPERATION (CONT)



CAUTION

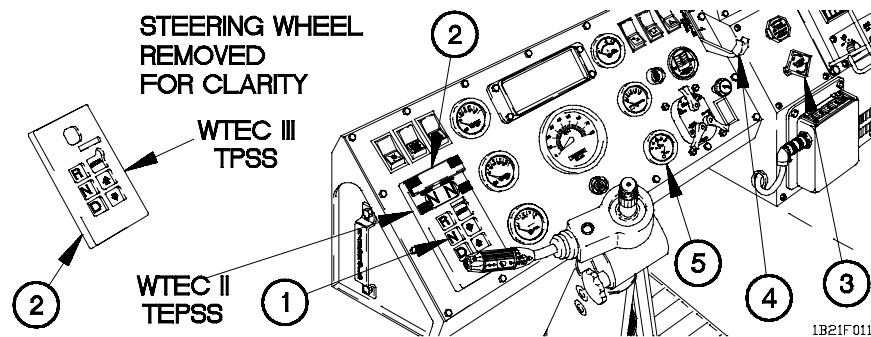
If illumination of last selected gear (in left side of LED display) goes out, WTEC II TEPSS or WTEC III TPSS has detected a problem that needs correcting. Do not attempt to shift transmission to N (Neutral) or any other gear. Operate vehicle at reduced speed to a safe parking location. Failure to comply may result in damage to equipment.

NOTE

Perform steps (6) through (9) if left side of LED display is not showing a selected gear.

- (6) Stop vehicle (para 2-21d).
- (7) Position master power switch (5) to off.
- (8) Pull out SYSTEM PARK control (2).
- (9) Notify Unit Maintenance.

f. Shut Down Engine.



- (1) Stop vehicle (para 2-21d).
- (2) Press N (Neutral) button (1) on WTEC II TEPSS (2) or WTEC III TPSS (2).
- (3) Pull out SYSTEM PARK control (3).

CAUTION

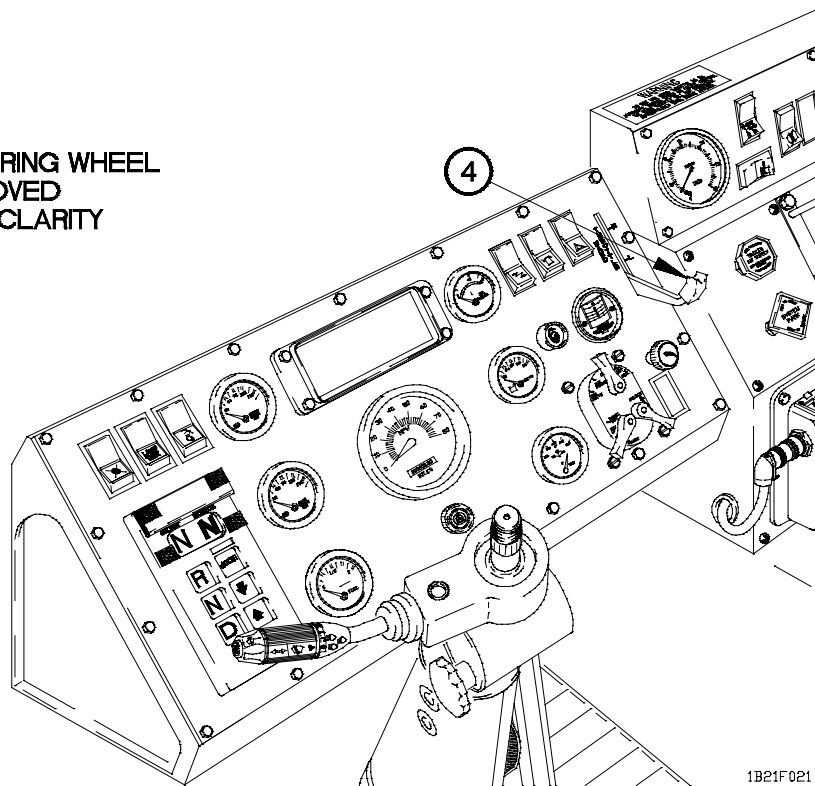
- Engine temperature must be maintained at a minimum of 165° F (74° C) for final 15 minutes prior to engine shutdown. Failure to comply may result in damage to engine.
- When outside temperatures are below 32° F (0° C) do not continuously operate engine above 1,250 to 1,450 rpm or HAND THROTTLE lever above L. Failure to comply may result in damage to equipment.

NOTE

- Steps (4) through (6) are only necessary to meet 165° F (74° C) requirements.
 - Perform step (4) if it is necessary to increase WATER TEMP to 165° F (74° C) and it can be accomplished using accelerator pedal or HAND THROTTLE lever, within approximately 20 minutes.
 - In the event of a tachometer failure a HAND THROTTLE lever positioned to L is approximately 1,250 to 1,450 rpm.
- (4) Set engine speed to 1,250 to 1,450 rpm or place HAND THROTTLE lever (4) to L until WATER TEMP gage (5) reaches and maintains 165° F (74° C) for 15 minutes.

2-21. VEHICLE OPERATION (CONT)

STEERING WHEEL
REMOVED
FOR CLARITY



- (5) Set engine speed to idle (750 rpm) or decrease HAND THROTTLE lever (4) to full down position.

NOTE

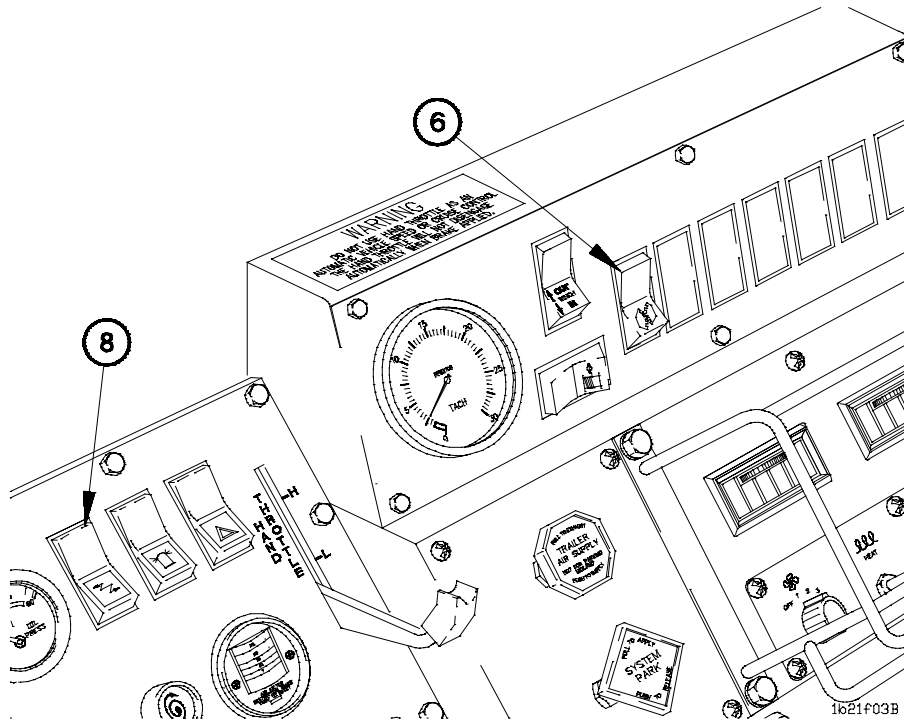
Perform step (6) only when it is difficult to achieve normal operating temperature of 165° F (74° C) due to extreme low outside temperatures.

- (6) Perform Rapid Engine Warm-Up (para 2-59) to reach and maintain 165° F (74° C) for 15 minutes.

CAUTION

A coast down time of one to three minutes is required for turbocharger before engine can be shut down. Failure to comply may result in damage to equipment.

- (7) Run engine at idle (750 rpm) for one to three minutes.



NOTE

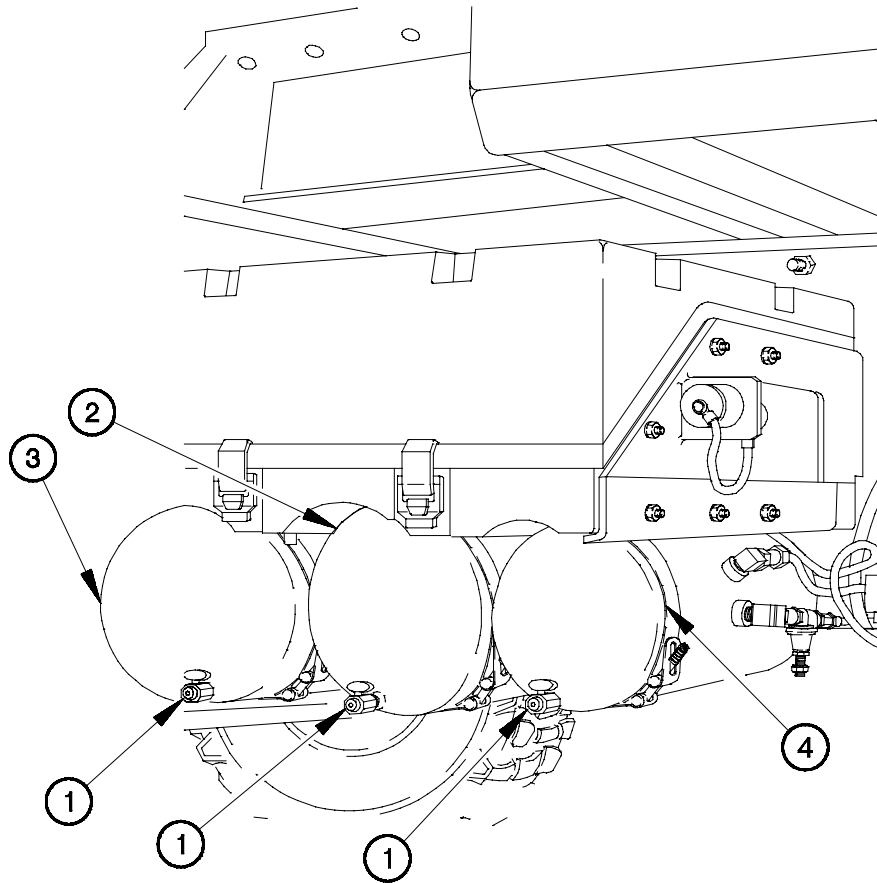
Perform step (8) only if vehicle is equipped with PTO.

- (8) Position PTO switch (6) to off (if PTO is engaged).
- (9) Turn off lights and electrical accessories (para 2-21c).

- (10) Deleted.
- (11) Position master power switch (8) to off.
- (12) Chock wheels (para 2-21h).

2-21. VEHICLE OPERATION (CONT)

g. Draining Air Tanks.



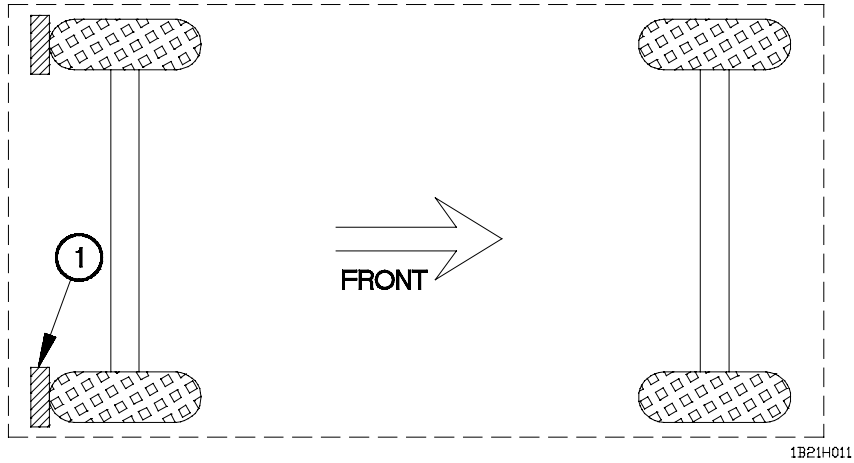
1B21G011

NOTE

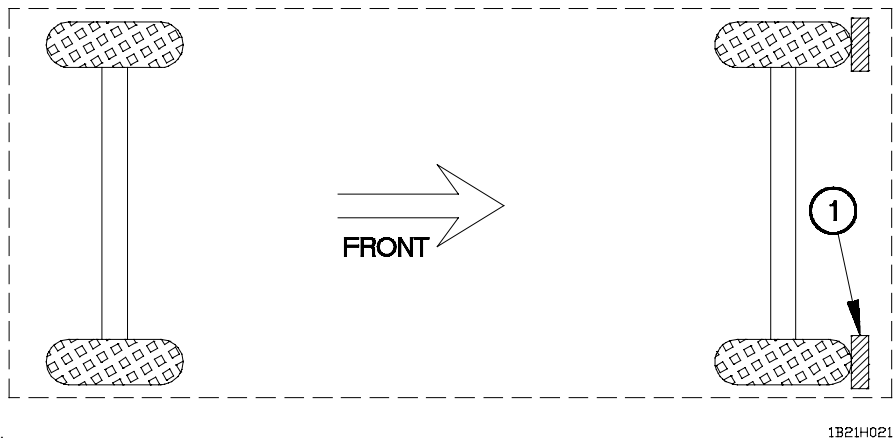
When vehicle will not be operated for 12 hours or more or when operating in temperatures below 50° F (10° C), air tanks should be drained.

- (1) Open drain valves (1) on primary air tank (2), secondary air tank (3), and wet tank (4) until air cannot be heard escaping.
- (2) Close drain valves (1) on primary air tank (2), secondary air tank (3), and wet tank (4).

h. Parking Vehicle.

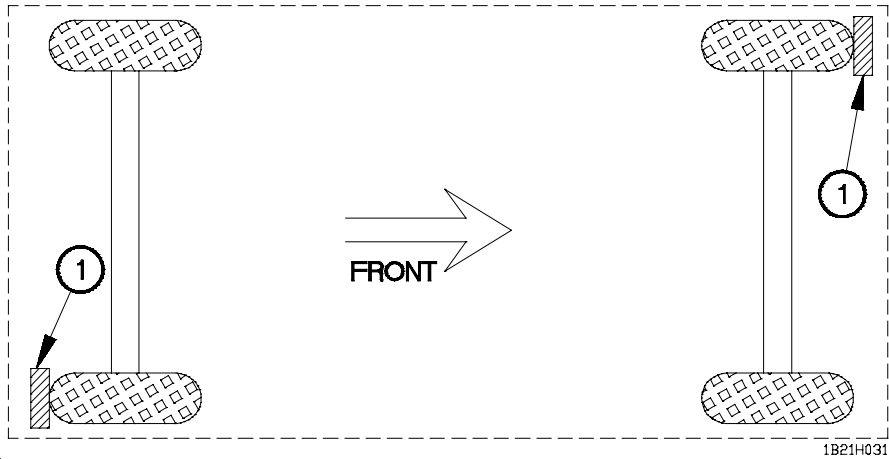


(1) Install wheel chocks (1) in back of rear wheels when parked facing uphill.



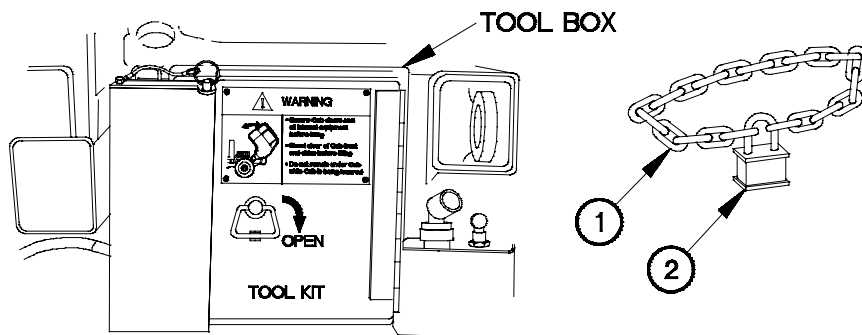
(2) Install wheel chocks (1) in front of front wheels when parked facing downhill.

2-21. VEHICLE OPERATION (CONT)

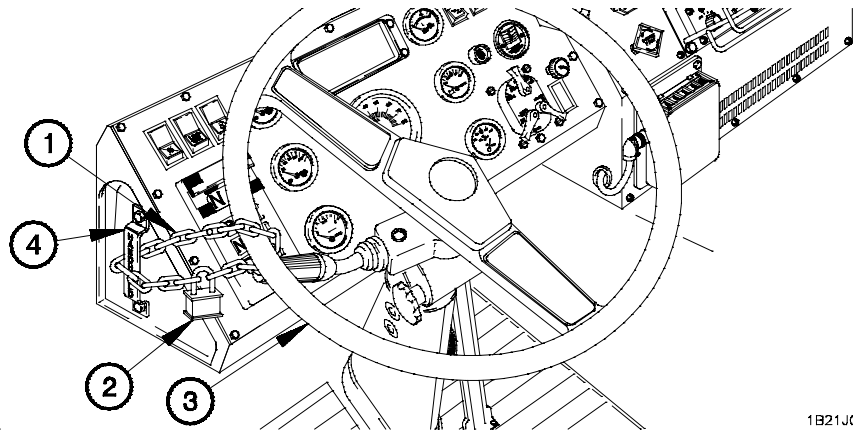


- (3) Install wheel chocks (1) in front of one front wheel and the second wheel chock in back of the opposite wheel when parked on level ground.

j. Securing Vehicle.



- (1) Install Chain.
 - (a) Remove chain (1) and padlock (2) from tool box.



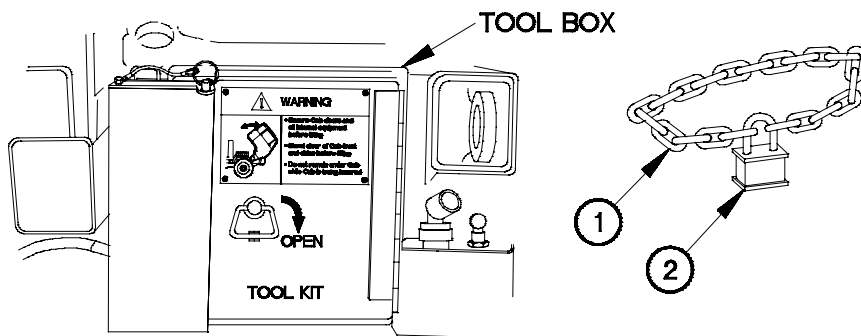
NOTE

Turn steering wheel either full right or full left before installing chain.

- (b) Wrap chain (1) around steering wheel (3) and cab handhold (4).
- (c) Connect padlock (2) to chain (1) and lock padlock.

(2) Remove Chain.

- (a) Unlock and remove padlock (2) from chain (1).
- (b) Remove chain (1) from steering wheel (3) and cab handhold (4).



- (c) Place chain (1) and padlock (2) in tool box.

2-22. RAISING/LOWERING CAB

a. Raising Cab.

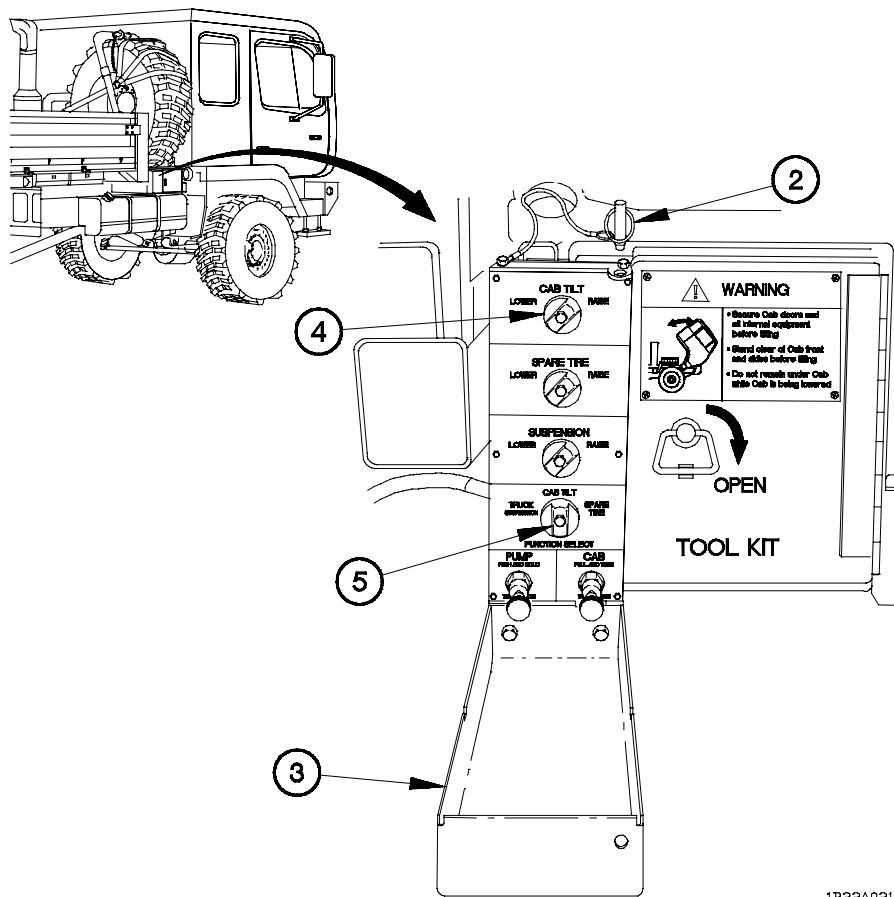
WARNING

- Engine compartment and accessories may be extremely hot when engine is running or has been running recently. Use caution around engine when cab is raised. Failure to comply may result in injury to personnel.
- Engine compartment contains a partially exposed fan blade. Extreme care must be taken when working in engine compartment. Failure to comply may result in injury to personnel.

NOTE

Cab will not raise unless SYSTEM PARK is pulled out.

(1) Deleted.



1B22A021

- (2) Remove pin (2) from hydraulic manifold cover (3).

NOTE

If air tanks are fully charged, cab may be raised and lowered twice without starting engine.

- (3) Turn CAB TILT knob (4) to the RAISE position.
 (4) Turn FUNCTION SELECT knob (5) to the CAB TILT position.

2-22. RAISING/LOWERING CAB (CONT)

WARNING

- Never raise cab while occupied or parked uphill on a steep grade. Failure to comply may result in serious injury or death to personnel.
- Ensure both doors are securely closed before cab is raised/lowered. Do not allow personnel near cab when cab is being raised/lowered. Cab doors could open. Failure to comply may result in serious injury or death to personnel or damage to equipment.

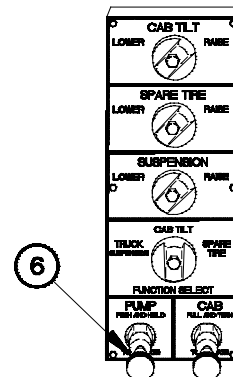
CAUTION

- Remove all loose objects from cab before raising cab. Failure to comply may result in damage to equipment.
- Cab height when raised is higher than normal. Ensure area above and in front of cab is adequate before raising cab. Failure to comply may result in damage to equipment.
- Ensure cab top is secure on air drop models before raising cab. Failure to comply may result in damage to equipment.

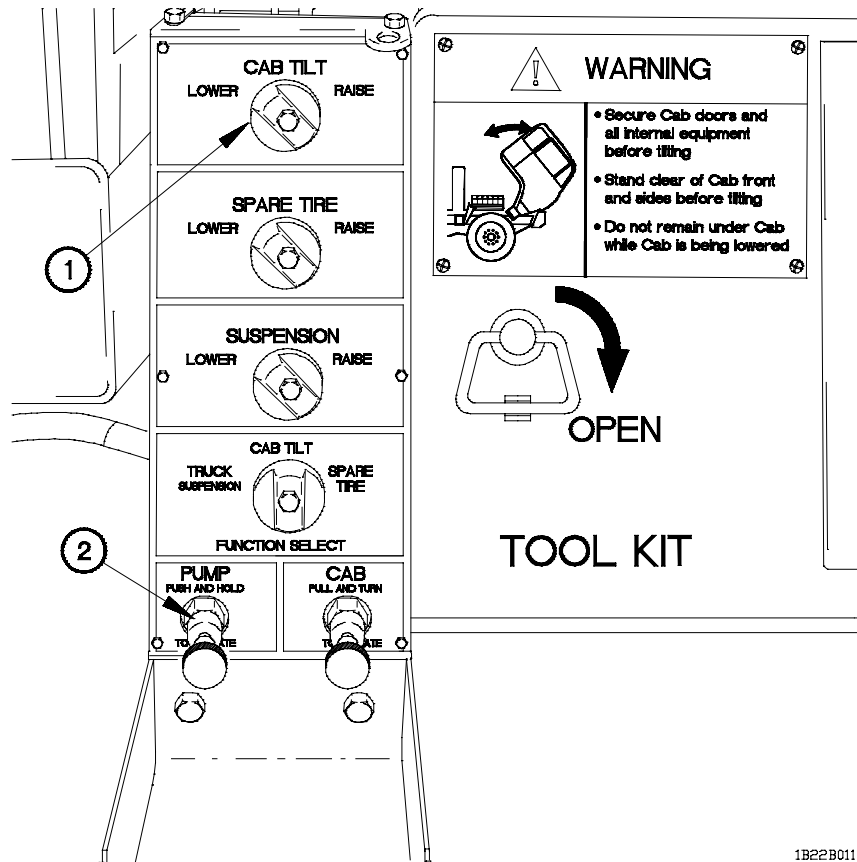
NOTE

Use back-up hydraulic pump (para 2-41) if pressing PUMP knob does not accomplish step (5).

- (5) Press and hold PUMP knob (6) until cab is fully raised.



b. Lowering Cab.



1B22B011

WARNING

Do not allow personnel near cab while cab is being lowered. Cab doors could open. Failure to comply may result in serious injury or death to personnel.

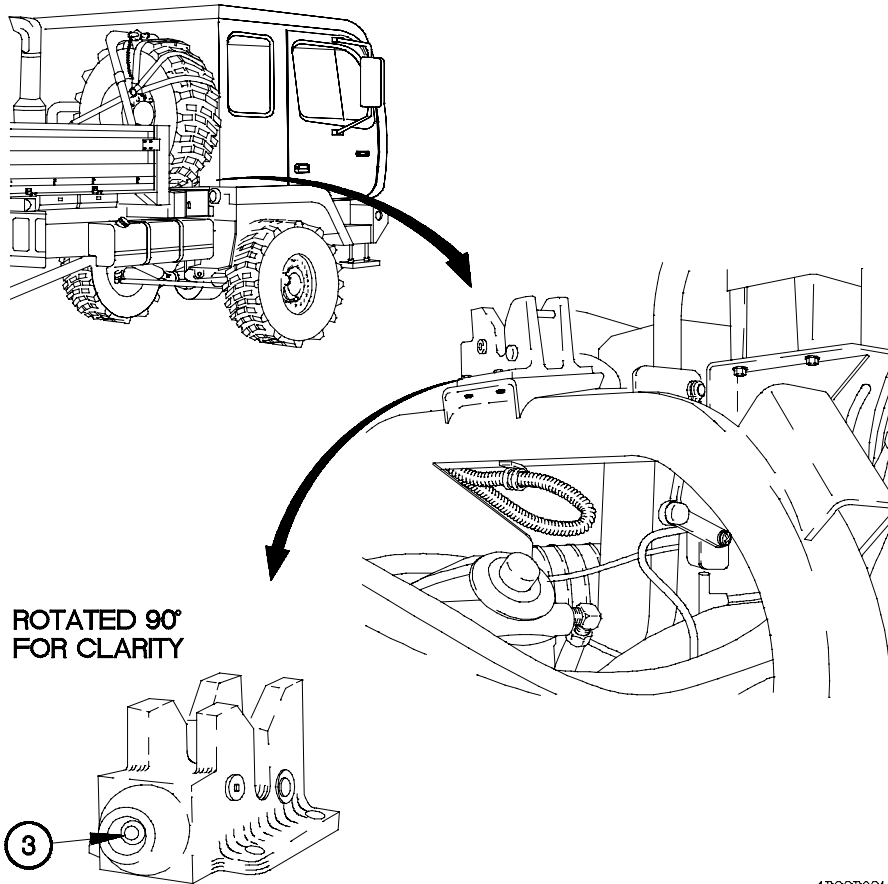
- (1) Turn CAB TILT knob (1) to the LOWER position.

NOTE

Use back-up hydraulic pump (para 2-41) if pressing PUMP knob does not accomplish step (2).

- (2) Press and hold PUMP knob (2) until cab is fully lowered.

2-22. RAISING/LOWERING CAB (CONT)



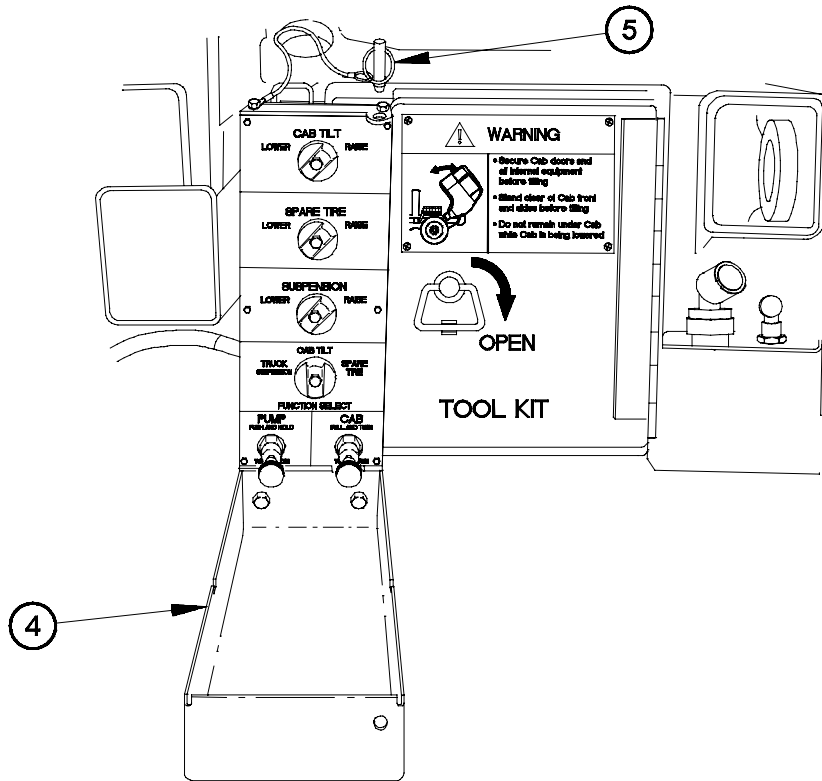
WARNING

Cab hydraulic latch must be locked before driving vehicle. Failure to comply may result in serious injury or death to personnel or damage to equipment.

NOTE

Button on right side end of cab hydraulic latch shows status of latch. Button in shows cab is latched; button out shows cab is not latched.

- (3) Check button (3) position to confirm cab is latched.

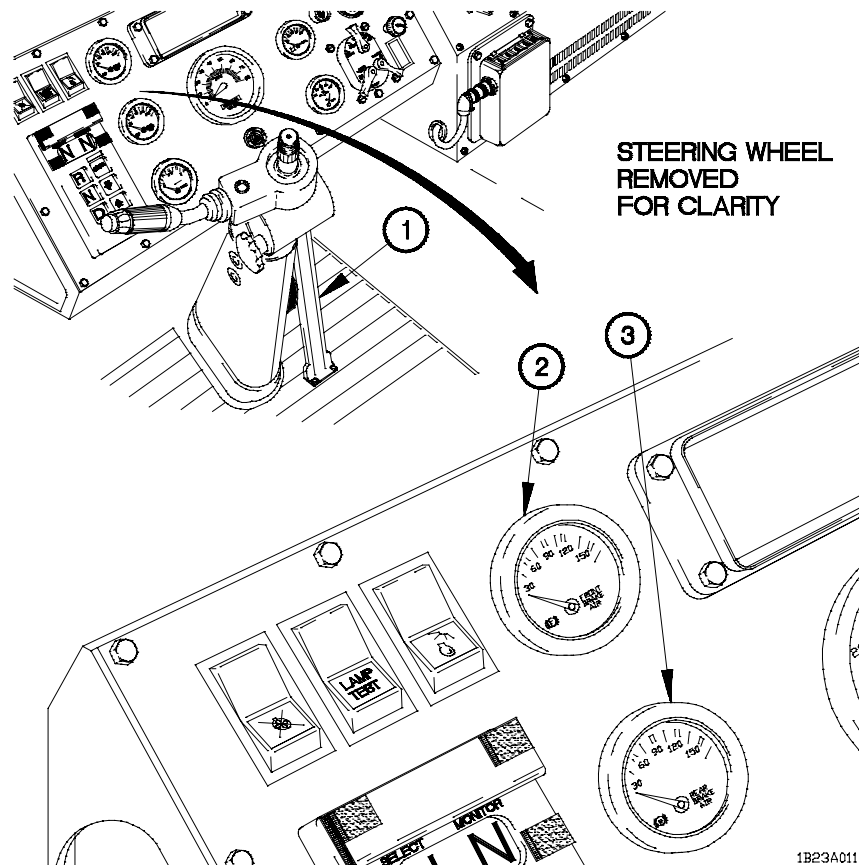


1B22B031

- (4) Close hydraulic manifold cover (4).
- (5) Install pin (5) in hydraulic manifold cover (4).

2-23. CENTRAL TIRE INFLATION SYSTEM (CTIS) OPERATION

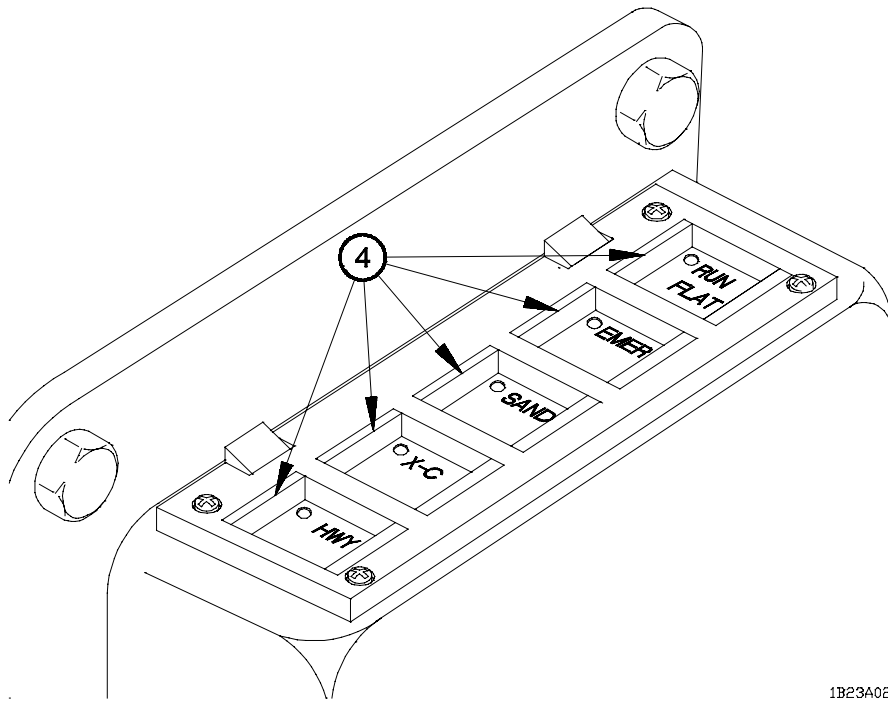
a. Normal CTIS Operation.



- (1) Start engine (para 2-21a or b).

NOTE

- If vehicle is stopped when CTIS mode is changed, it may be necessary to increase engine speed to provide adequate air supply to tires.
 - CTIS will automatically shut off when air system pressure drops below 74 psi (510 Kpa), or when CTIS malfunction occurs.
- (2) Slowly press down on accelerator pedal (1) if FRONT BRAKE AIR pressure gage (2) and REAR BRAKE AIR pressure gage (3) read less than 100 psi (690 kPa).



1B23A021

NOTE

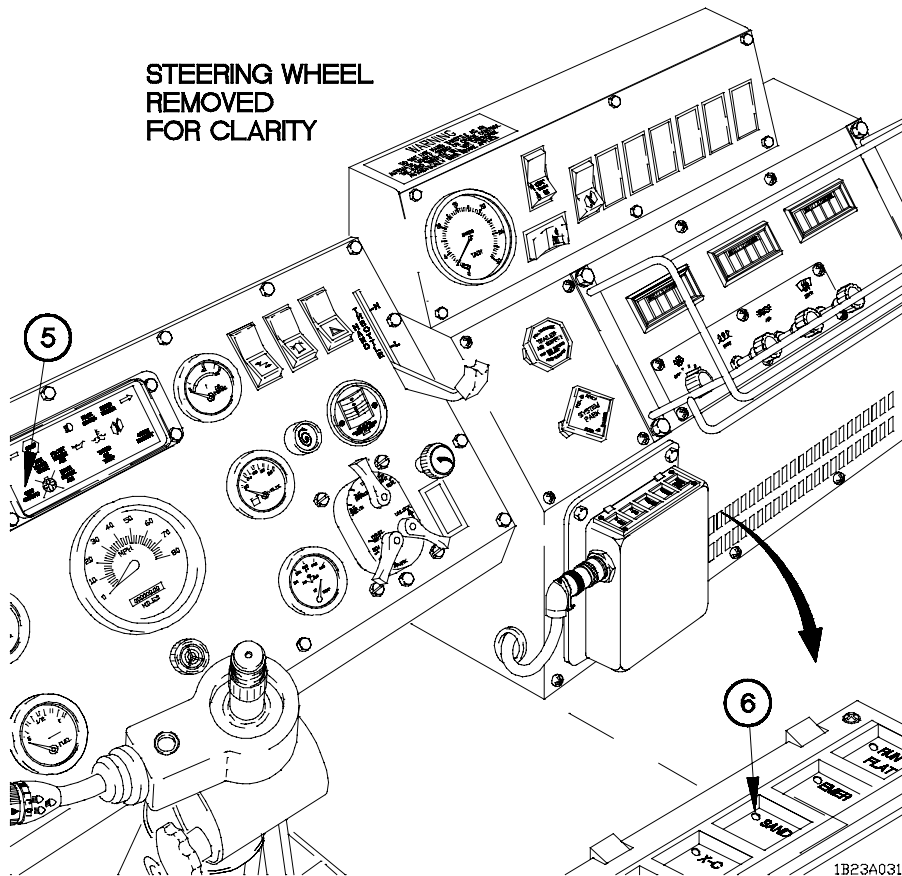
Mode light on CTIS ECU will flash when tire pressure is changing to air pressure setting for that mode. Mode light will illuminate steady when tire reaches air pressure setting for that mode.

- (3) Press appropriate CTIS mode button (4) for vehicle speed and terrain conditions (Refer to Table 2-5. Central Tire Inflation System (CTIS) Tire Pressures and Restrictions).

Table 2-5. Central Tire Inflation System (CTIS) Tire Pressures and Restrictions

Operating Mode	Maximum Speed	Time Restriction	Tire Pressure
Highway	55 mph (88 km/h)	NONE	55 psi (379 kPa)
Cross-Country	40 mph (64 km/h)	NONE	33 psi (228 kPa)
Sand	12 mph (19 km/h)	NONE	20 psi (138 kPa)
Emergency	5 mph (8 km/h)	10 MINUTES	14 psi (97 kPa)

**2-23. CENTRAL TIRE INFLATION SYSTEM (CTIS) OPERATION
(CONT)**

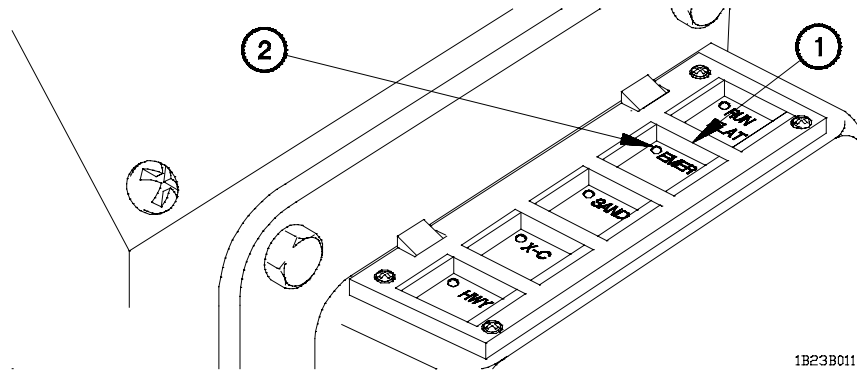


NOTE

If average speed of vehicle exceeds speed limit of selected CTIS mode for one minute, CTIS OVRSPD indicator will flash. If average speed of vehicle exceeds speed limit of selected CTIS mode for two minutes, CTIS will automatically inflate tires to pressure setting of next higher mode.

- (4) If CTIS OVRSPD indicator (5) flashes, reduce vehicle speed until CTIS OVRSPD indicator goes out. Check that CTIS mode light (6) illuminates steady. Steady illumination of CTIS mode light indicates vehicle speed is correct for CTIS mode selected.

b. Operate in Emergency (EMER) Mode.



CAUTION

- Do not exceed 5 mph (8 km/h) when CTIS is operating in EMER mode. Operating vehicle in EMER mode is limited to ten minutes. Failure to comply may result in damage to equipment.
- Continued operation in EMER mode will result in eventual reduction in tire life. Failure to comply may result in damage to equipment.

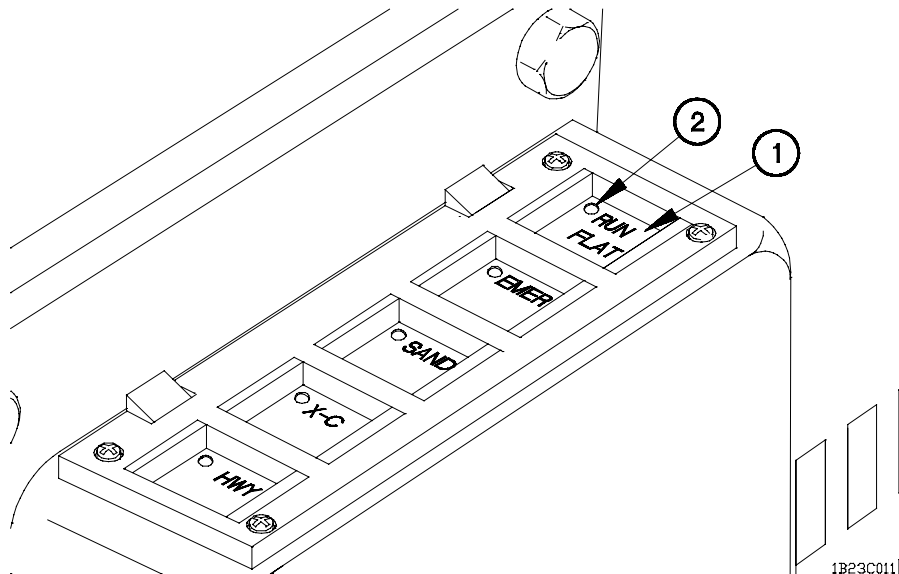
NOTE

- CTIS OVRSPD indicator will flash when in EMER mode, regardless of speed.
- CTIS is operated in EMER mode when a lower tire pressure (14 psi) (97 kPa) is needed to free vehicle from a stuck condition or to travel a short distance over terrain that is known to require tire pressure less than 25 psi (172 kPa). Time at this pressure is limited to ten minutes after which time inflation to SAND will begin. If Operator still requires EMER mode, then EMER mode button must be pressed again.

- (1) Press EMER mode button (1). EMER mode light (2) will illuminate while CTIS is operating in EMER mode.
- (2) If operating CTIS in EMER mode is no longer required, press EMER mode button (1) again. EMER mode light (2) will go out.

2-23. CENTRAL TIRE INFLATION SYSTEM (CTIS) OPERATION (CONT)

c. Operate in Run Flat Mode.



CAUTION

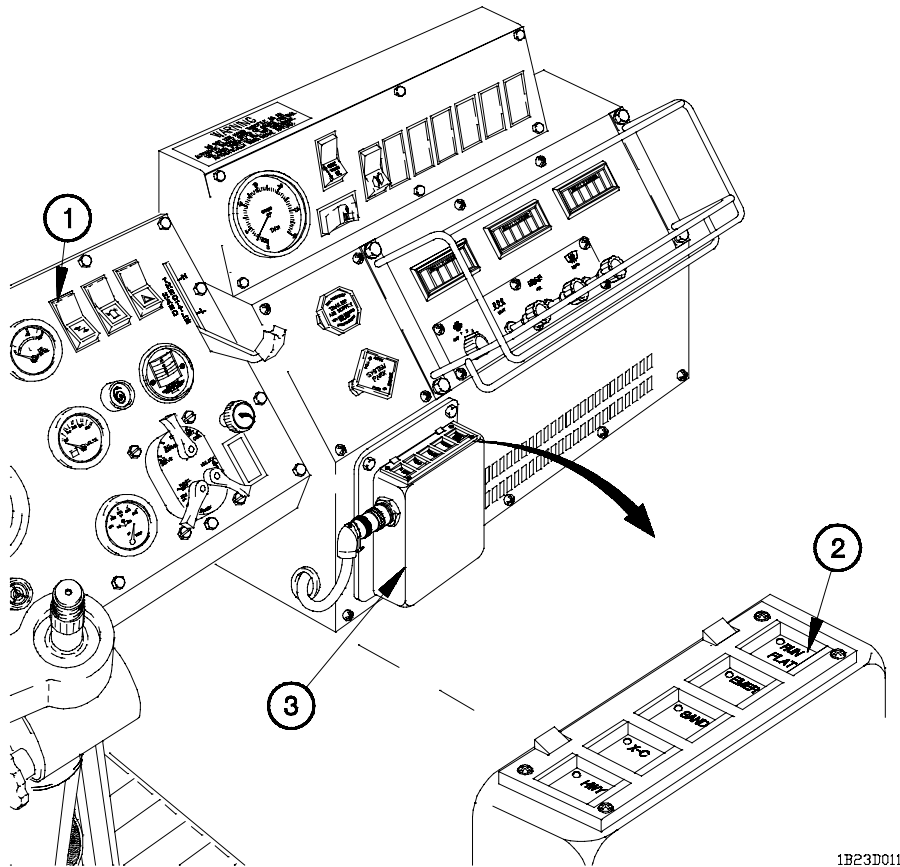
CTIS operation in RUN FLAT mode is limited to ten minutes. To continue operating CTIS in RUN FLAT mode after ten minutes, RUN FLAT mode button must be pressed again or CTIS will shut down completely. Failure to comply may result in damage to equipment.

NOTE

CTIS is operated in RUN FLAT mode when tire(s) have been punctured. RUN FLAT mode causes CTIS to check tire pressure every 15 seconds (normal interval is every 15 minutes). If low air pressure is sensed, CTIS will supply air in wet tank to leaking tire(s) every 15 seconds.

- (1) Press RUN FLAT mode button (1). RUN FLAT mode light (2) will illuminate when CTIS is operating in RUN FLAT mode.
- (2) If operating CTIS in RUN FLAT mode is no longer required, press RUN FLAT mode button (1) again. RUN FLAT mode light (2) will go out.
- (3) Change leaking tire(s) (para 3-5) as soon as possible.

d. Reset CTIS.



NOTE

- If all five CTIS ECU mode lights flash, perform steps (1) through (4).
- If all five CTIS ECU mode lights continue to flash, notify Unit Maintenance.

- (1) Position master power switch (1) to off.
- (2) Position master power switch (1) to on.
- (3) Press RUN FLAT mode button (2) on CTIS ECU (3).
- (4) Start engine (para 2-21a or b).

2-24. LIGHT MATERIAL HANDLING CRANE (LMHC) OPERATION

a. Determine Required LMHC Settings.

- (1) Determine the weight of load.
- (2) Determine the radius from centerline of LMHC rotation to position of load.
- (3) To determine boom angle and length required for load being lifted see Table 2-6.

Example:

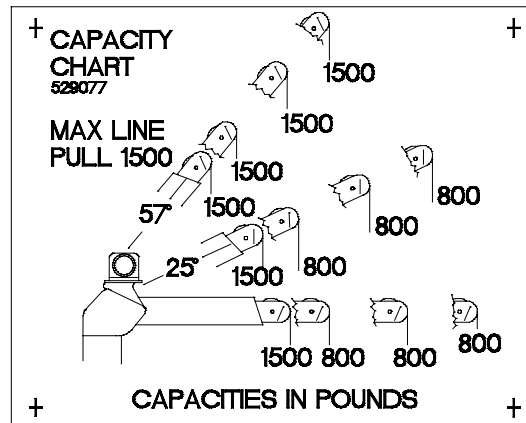
- Load to be lifted from ground is at a radius of 48 in. (122 cm) from LMHC centerline of rotation and must be placed on cargo bed.

Step 1. Determine the load

Load = 1,200 lbs (549 kgs)
 Sling = 10 lbs (5 kgs)
 Total Load = 1,210 lbs (549 kgs)

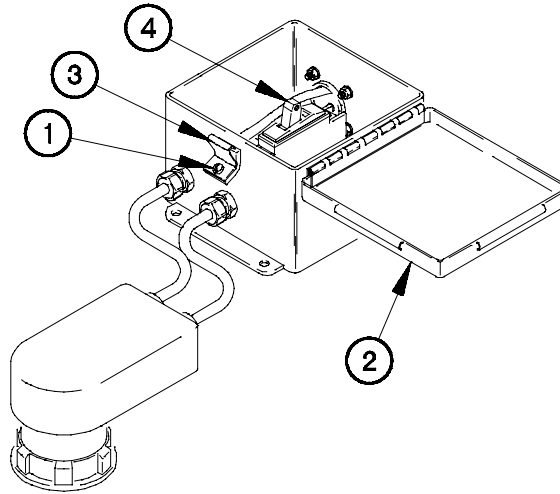
Step 2. Refer to Capacity Chart in Table 2-6 to see that load does not exceed ratings.

Table 2-6. Capacity Chart for Light Material Handling Crane (LMHC).



1B24A011

b. Reset Circuit Breaker.



1B24B011

NOTE

Circuit breaker located inside circuit breaker box will occasionally trip due to sudden high amperage inputs. If circuit breaker trips more than four times during a mission, notify Unit Maintenance.

- (1) Loosen, but do not remove, three screws (1) securing box cover (2).
- (2) Rotate three clamps (3) and open box cover (2).

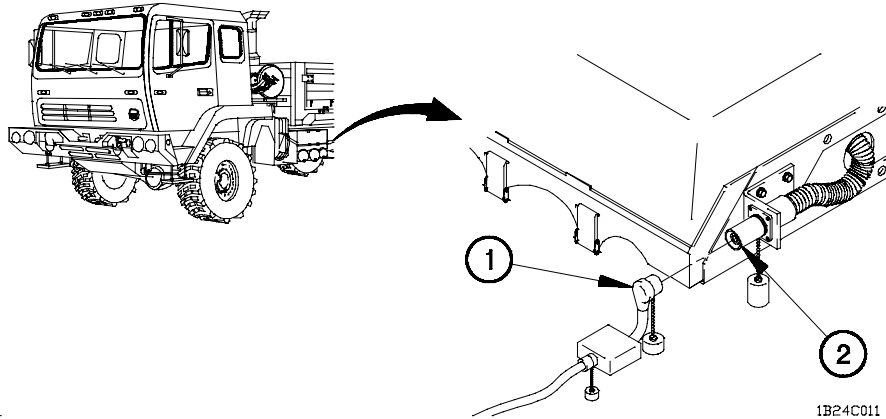
CAUTION

Use care when positioning circuit breaker switch so as not to upset mounting lugs. Failure to comply may result in damage to equipment.

- (3) Position circuit breaker switch (4) to ON.
- (4) Close box cover (2) and rotate three clamps (3) back to original position.
- (5) Tighten three screws (1).

2-24. LIGHT MATERIAL HANDLING CRANE (LMHC) OPERATION (CONT)

c. Changing LMHC Location.



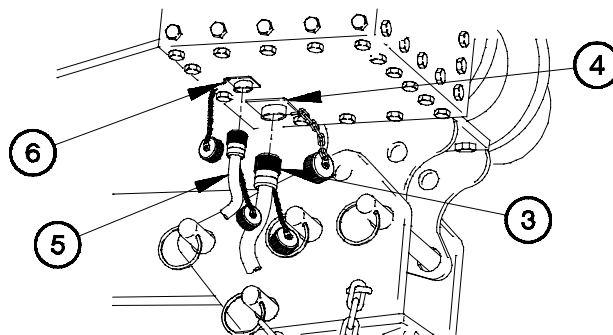
WARNING

Ensure that engine is not running before disconnecting circuit breaker box NATO connector from vehicle NATO connector. Failure to comply may result in injury to personnel.

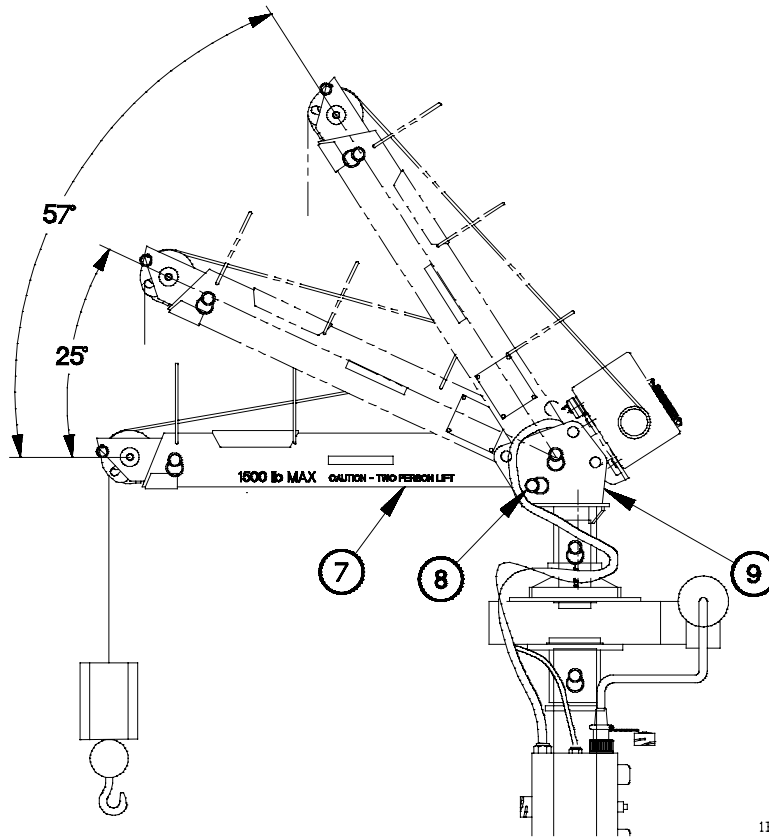
CAUTION

Ensure that power cable does not come in contact with exhaust pipe. Failure to comply may result in damage to equipment.

- (1) Disconnect circuit breaker box NATO connector (1) from vehicle NATO connector (2).



- (2) Disconnect power cable connector (3) from winch power cable connector (4).
- (3) Disconnect remote control connector (5) from winch remote control connector (6).

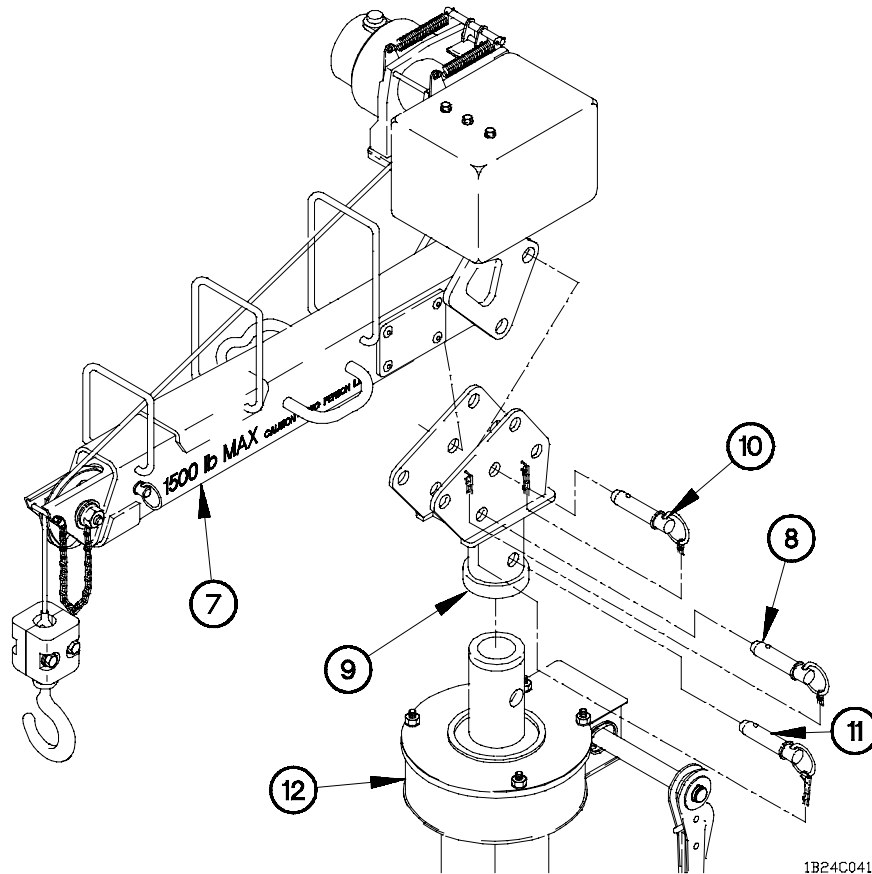


NOTE

- Perform steps (4) through (8) if boom was in 25-degree or 57-degree position.
- Steps (4) through (8) require the aid of an assistant.

- (4) Support end of boom (7).
- (5) Remove quick release pin (8) from turret (9).
- (6) Lower boom (7) to 0-degrees.
- (7) Align holes in turret (9) and boom (7).
- (8) Install quick release pin (8) in turret (9).

**2-24. LIGHT MATERIAL HANDLING CRANE (LMHC) OPERATION
(CONT)**



(9) Remove quick release pins (8) and (10) from turret (9).

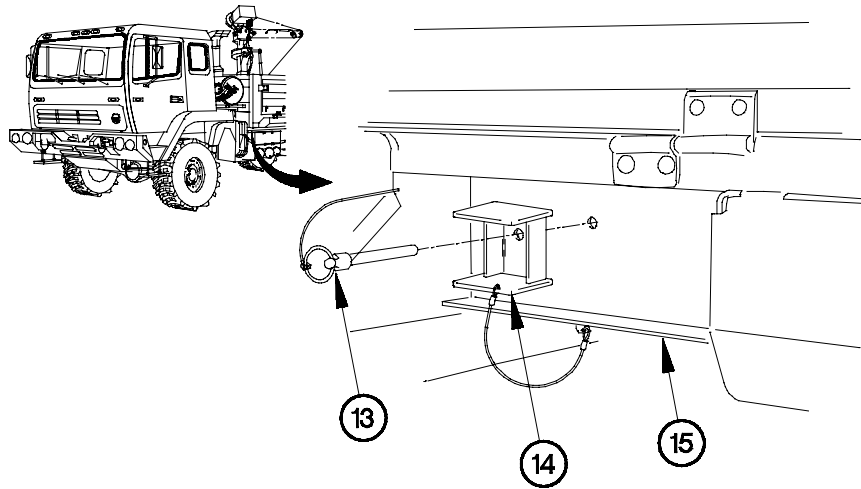
WARNING

Light Material Handling Crane (LMHC) boom and winch weighs approximately 110 lbs (50 kgs). The aid of an assistant is required to remove LMHC boom and winch. Failure to comply may result in injury to personnel.

(10) Remove boom (7) from turret (9).

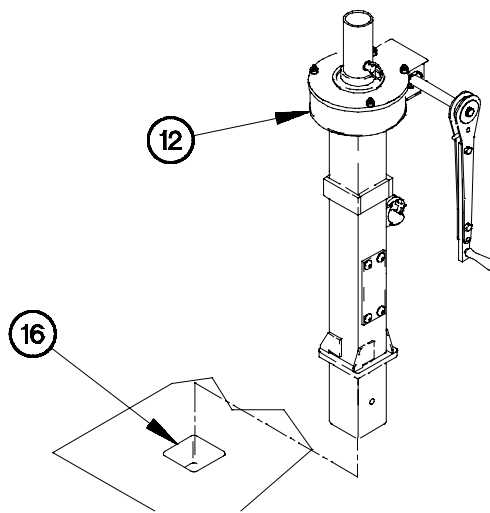
(11) Remove quick release pin (11) from turret (9).

(12) Remove turret (9) from mast (12).



1B24C051

(13) Remove quick release pin (13) and plug (14) from cargo bed (15).



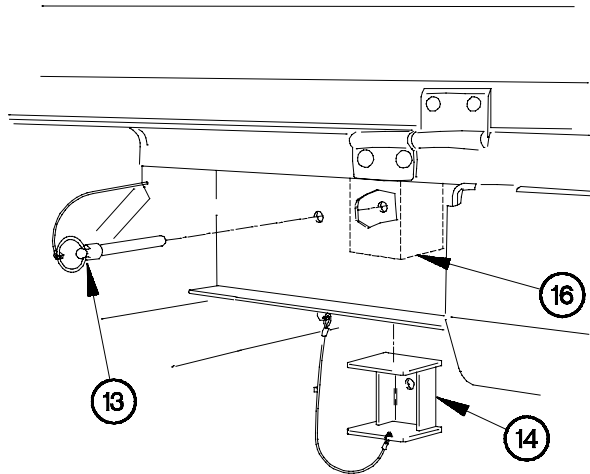
1B24C061

WARNING

Light Material Handling Crane (LMHC) mast weighs approximately 110 lbs (50 kgs). Use the aid of an assistant to remove mast from cargo bed pocket. Failure to comply may result in injury to personnel.

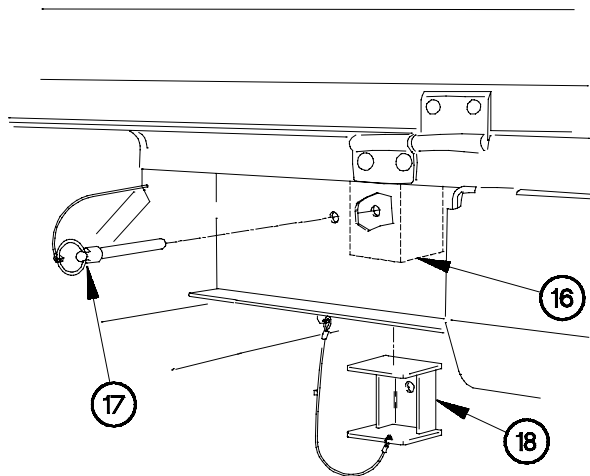
(14) Remove mast (12) from cargo bed pocket (16).

**2-24. LIGHT MATERIAL HANDLING CRANE (LMHC) OPERATION
(CONT)**



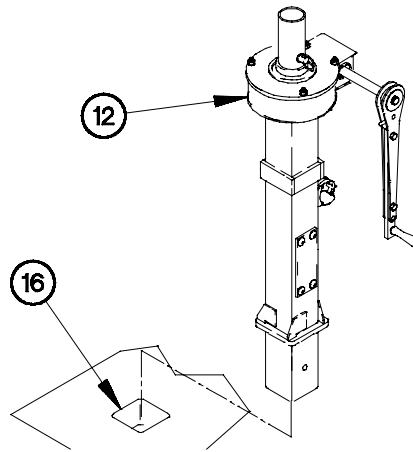
1B24C071

(15) Install plug (14) in cargo bed pocket (16) with quick release pin (13).



1B24C081

(16) Remove quick release pin (17) and plug (18) from desired cargo bed pocket (16).



1B24C091

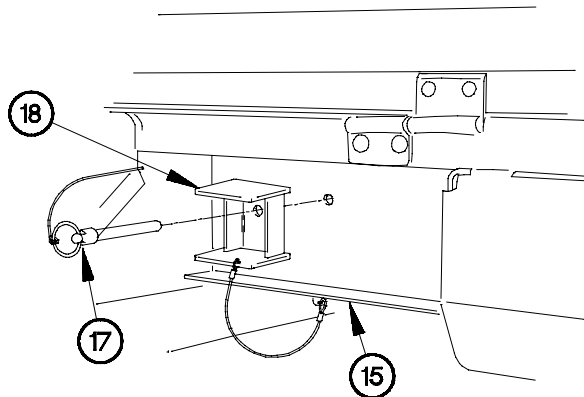
WARNING

Light Material Handling Crane (LMHC) mast weighs approximately 110 lbs (50 kgs). Use the aid of an assistant to install mast in cargo bed pocket. Failure to comply may result in injury to personnel.

NOTE

Position mast in cargo bed pocket so handle does not extend over front or rear edge of cargo bed.

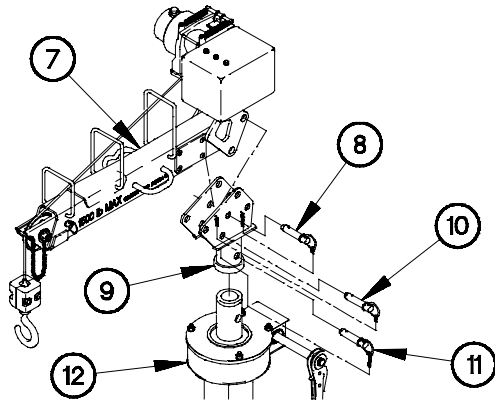
(17) Install mast (12) in cargo bed pocket (16).



1B24C101

(18) Install plug (18) on cargo bed (15) with quick release pin (17).

**2-24. LIGHT MATERIAL HANDLING CRANE (LMHC) OPERATION
(CONT)**



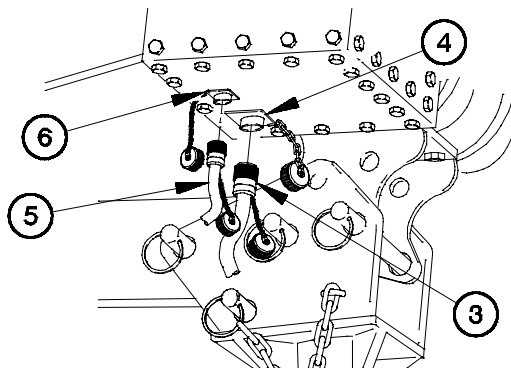
1B24C111

- (19) Position turret (9) on mast (12).
- (20) Install quick release pin (11) in turret (9).

WARNING

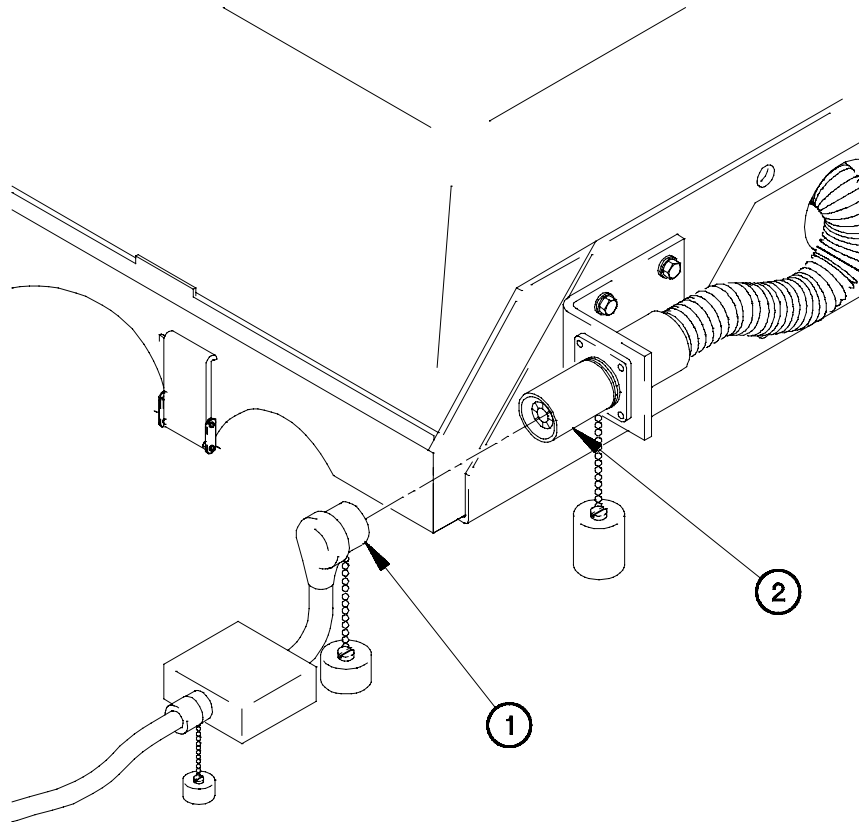
Light Material Handling Crane (LMHC) boom and winch weighs approximately 110 lbs (50 kg). The aid of an assistant is required to install boom and winch. Failure to comply may result in injury to personnel.

- (21) Position boom (7) on turret (9).
- (22) Install quick release pins (8) and (10) in turret (9).



1B24C121

- (23) Connect remote control connector (5) on winch remote control connector (6).
- (24) Connect power cable connector (3) on winch power cable connector (4).



1B24C131

WARNING

Ensure that engine is not running before disconnecting circuit breaker box NATO connector from vehicle NATO connector. Failure to comply may result in injury to personnel.

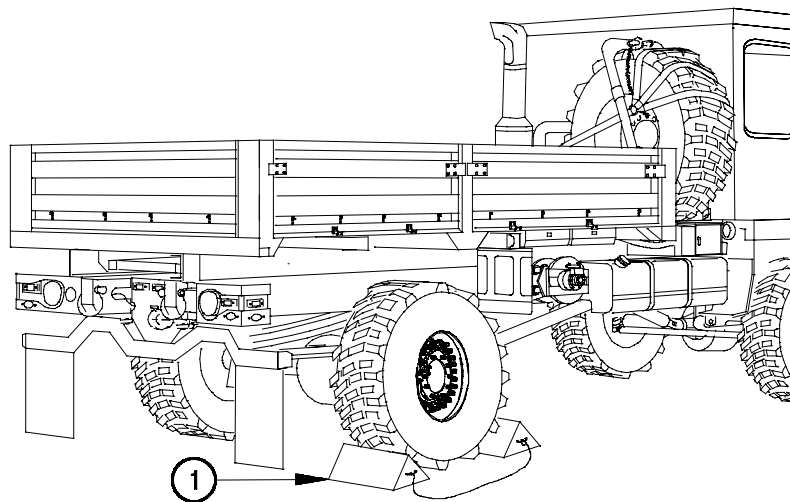
CAUTION

Ensure that power cable does not come in contact with exhaust pipe. Failure to comply may result in damage to equipment.

- (25) Connect circuit breaker box NATO connector (1) to vehicle NATO connector (2).

2-24. LIGHT MATERIAL HANDLING CRANE (LMHC) OPERATION (CONT)

d. Prepare LMHC for Use.

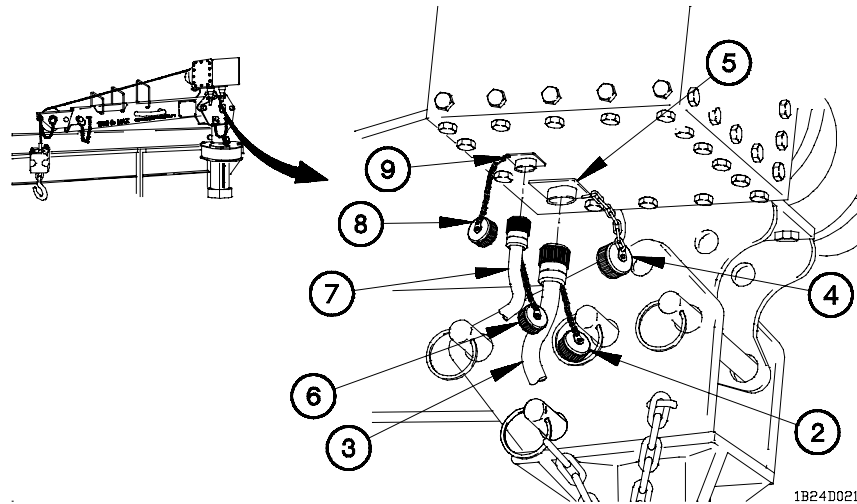


1B24D011

WARNING

- Cargo bed is approximately 5 ft (600 mm) above ground level. Use care during any Light Material Handling Crane (LMHC) operation. Failure to comply may result in serious injury or death to personnel.
- Ensure that wheels are chocked prior to setting up LMHC. Failure to comply may result in injury to personnel.

(1) Position wheel chocks (1) on rear wheels.

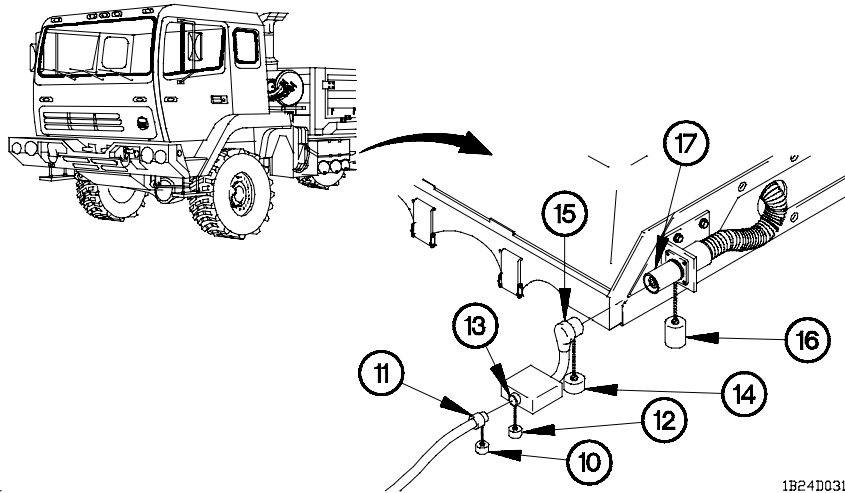


WARNING

Power cable must be connected to Light Material Handling Crane (LMHC) before being connected to circuit breaker box. Failure to comply may result in serious injury or death to personnel.

- (2) Remove dust cap (2) from power cable connector (3).
- (3) Remove dust cap (4) from winch power cable connector (5).
- (4) Connect power cable connector (3) to winch power cable connector (5).
- (5) Remove dust cap (6) from remote control connector (7).
- (6) Remove dust cap (8) from winch remote control connector (9).
- (7) Connect remote control connector (7) to winch remote control connector (9).

**2-24. LIGHT MATERIAL HANDLING CRANE (LMHC) OPERATION
(CONT)**



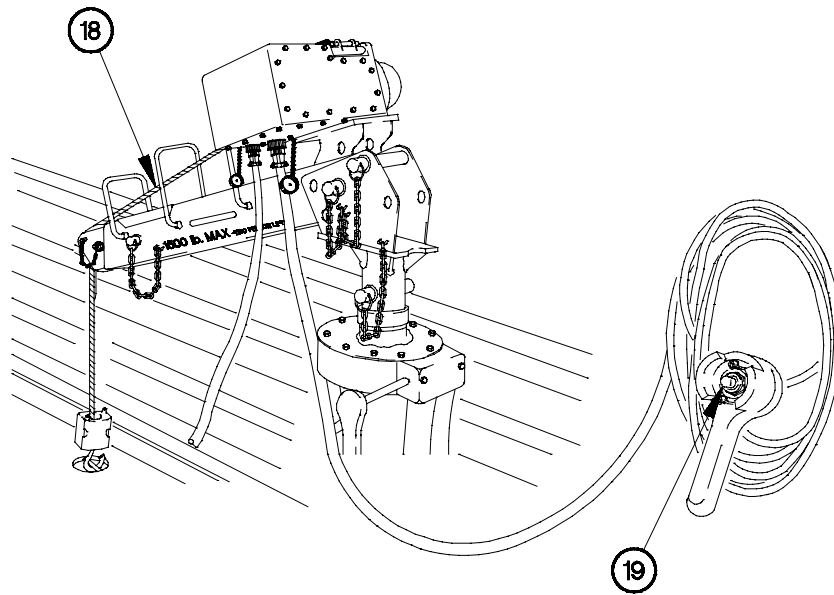
WARNING

Ensure that engine is shut down before connecting power cable at vehicle NATO connector. Failure to comply may result in serious injury or death to personnel.

CAUTION

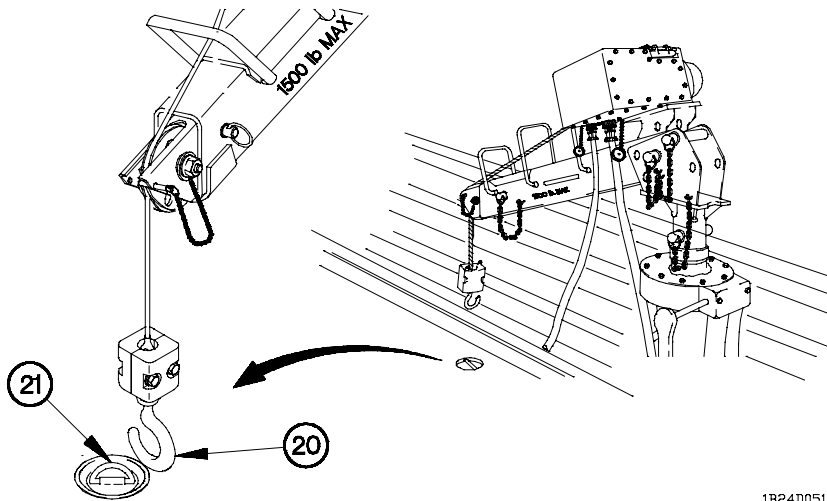
Ensure that power cable does not come in contact with hot exhaust pipe. Failure to comply may result in damage to equipment.

- (8) Remove dust cap (10) from power cable connector (11).
- (9) Remove dust cap (12) from circuit breaker box connector (13).
- (10) Connect power cable connector (11) to circuit breaker box connector (13).
- (11) Remove dust cap (14) from circuit breaker box NATO connector (15).
- (12) Remove dust cap (16) from vehicle NATO connector (17).
- (13) Connect circuit breaker box NATO connector (15) to vehicle NATO connector (17).



1B24D041

(14) To lower cable (18) place hoist control switch (19) in up position.

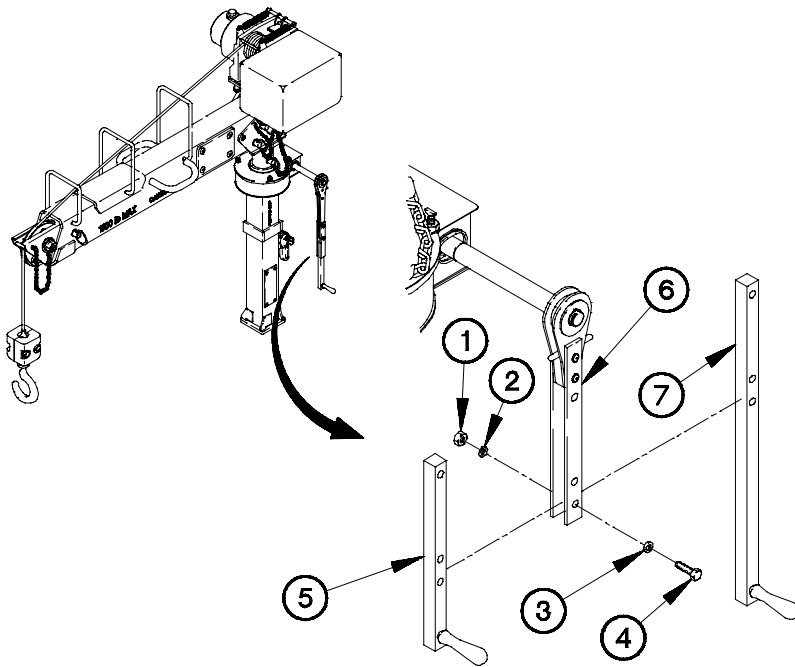


1B24D051

(15) Disconnect hook (20) from cargo bed tie-down ring (21).

**2-24. LIGHT MATERIAL HANDLING CRANE (LMHC) OPERATION
(CONT)**

e. Installing Long handle (if required).



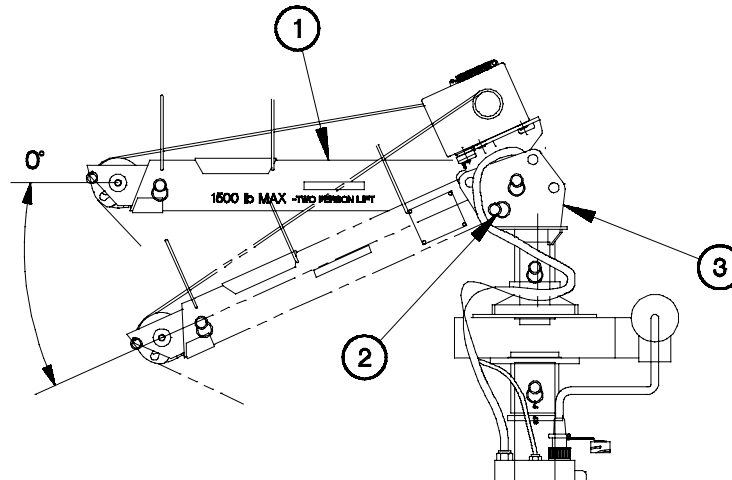
1B24E011

NOTE

The long handle may be installed and used to rotate crane. To remove short handle and install long handle perform steps (1) and (2).

- (1) Remove two nuts (1), lockwashers (2), washers (3), screws (4) and short handle (5) from ratchet (6).
- (2) Install long handle (7) in ratchet (6) with two washers (3), screws (4), lockwashers (2) and nuts (1).
- (3) Notify Unit Maintenance to replace lockwashers.

f. Raise Boom.



WARNING

Determine required Light Material Handling Crane (LMHC) settings prior to raising boom. Failure to comply may result in injury to personnel or damage to equipment.

NOTE

Steps (1) through (8) require the aid of an assistant.

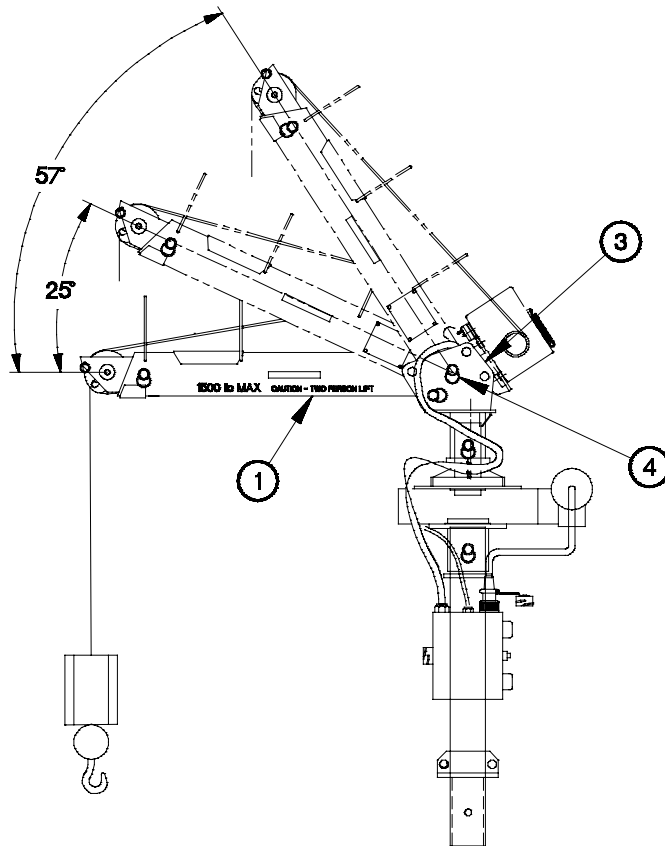
- (1) Support end of boom (1).

NOTE

Perform steps (2) through (5) to raise the boom to the 0-degree position.

- (2) Remove quick release pin (2) from turret (3).
- (3) Raise boom (1) to 0-degree position.
- (4) Align holes in turret (3) and boom (1).
- (5) Install quick release pin (2) in turret (3).

**2-24. LIGHT MATERIAL HANDLING CRANE (LMHC) OPERATION
(CONT)**



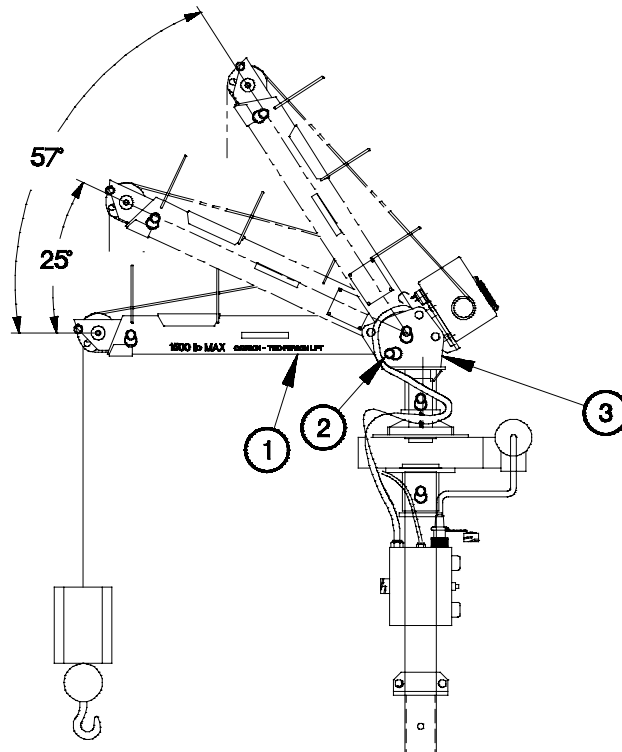
1B24F02B

NOTE

Perform steps (6) through (8) to raise boom to 25-degree or 57-degree position.

- (6) Remove quick release pin (4) from turret (3).
- (7) Raise boom (1) to desired position.
- (8) Install quick release pin (4) in turret (3).

g. Telescope Boom.



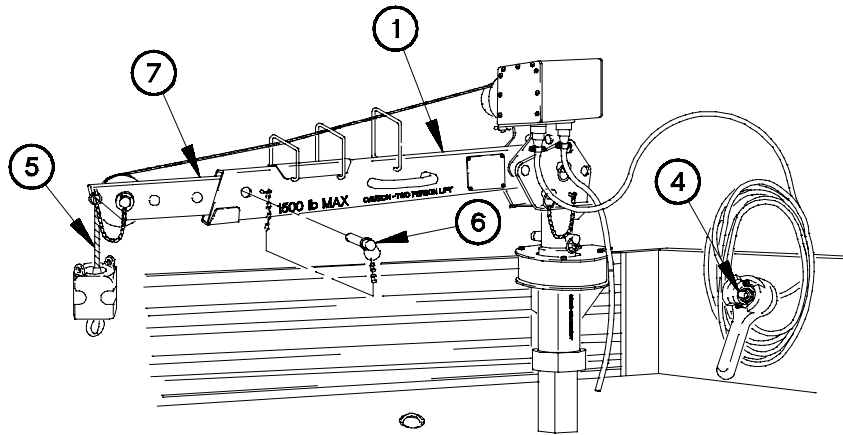
1B24G01B

NOTE

- Steps (1) through (5) require the aid of an assistant.
- Perform steps (1) through (5) if boom was in 25-degree or 57-degree position.

- (1) Support end of boom (1).
- (2) Remove quick release pin (2) from turret (3).
- (3) Lower boom (1) to 0-degrees.
- (4) Align holes in turret (3) and boom (1).
- (5) Install quick release pin (2) in turret (3).

**2-24. LIGHT MATERIAL HANDLING CRANE (LMHC) OPERATION
(CONT)**



1B24G021

CAUTION

Cable must be lowered to extend boom. Failure to comply may result in damage to equipment.

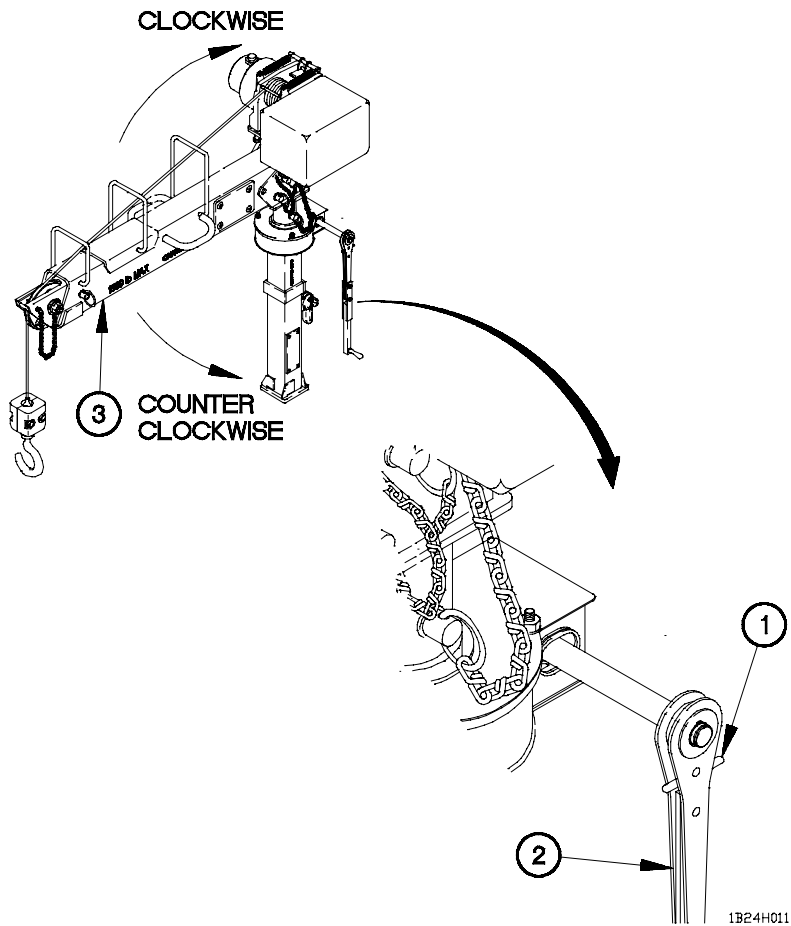
- (6) Place hoist control switch (4) in up position to pay out cable (5).
- (7) Remove quick release pin (6) from boom (1).
- (8) Set boom extension (7) to desired position.

WARNING

Determine required Light Material Handling Crane (LMHC) settings prior to telescoping boom. Failure to comply may result in injury to personnel or damage to equipment.

- (9) Align holes in boom extension (7) and boom (1).
- (10) Install quick release pin (6) in boom (1).

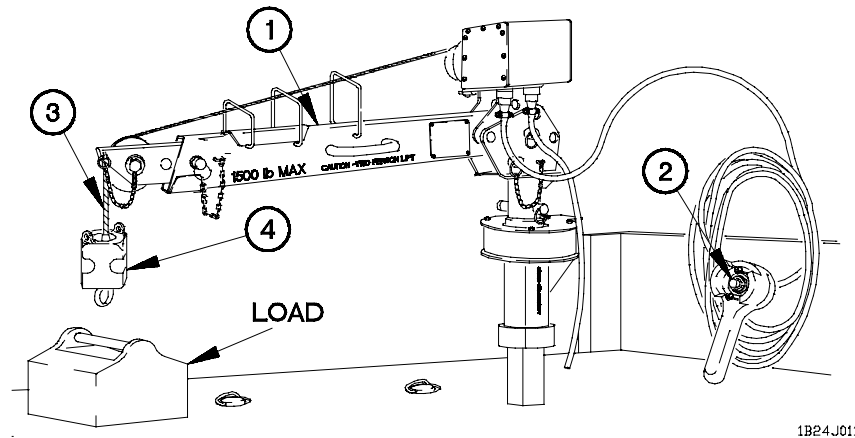
h. Swing Boom.



- (1) Press ratchet lever (1) counterclockwise.
- (2) Crank handle (2) to swing boom (3) counterclockwise.
- (3) Press ratchet lever (1) clockwise.
- (4) Crank handle (2) to swing boom (3) clockwise.

2-24. LIGHT MATERIAL HANDLING CRANE (LMHC) OPERATION (CONT)

j. Raise and Lower Load.



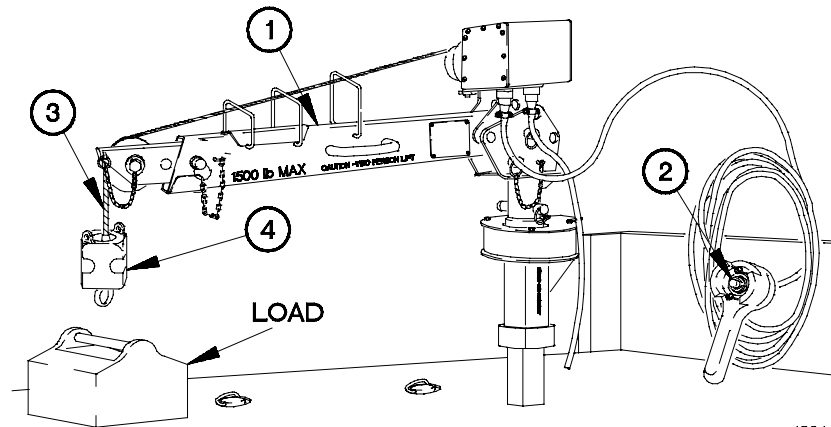
CAUTION

- Do not lift load over maximum load rating for Light Material Handling Crane (LMHC). Failure to comply may result in damage to equipment.
- Use only a straight pull when lifting load. Failure to comply may result in damage to equipment.
- After performing eight cycles with LMHC, allow 30 minutes to cool down. A cycle is defined as pickup, move, and place a load. A cycle may be from cargo bed of vehicle to ground or ground to cargo bed of vehicle. Failure to comply may result in damage to equipment.

NOTE

Steps (1) through (7) require the aid of an assistant.

- (1) Adjust boom (1) until end of boom is over load (para 2-24g).
- (2) Place hoist control switch (2) in up position to pay out cable (3).
- (3) Connect hook (4) to load.



1B24J021

WARNING

Ensure there are at least two wraps of cable on hoist drum at all times. Cable could come off hoist drum while load is being lifted. Failure to comply may result in injury to personnel or damage to equipment.

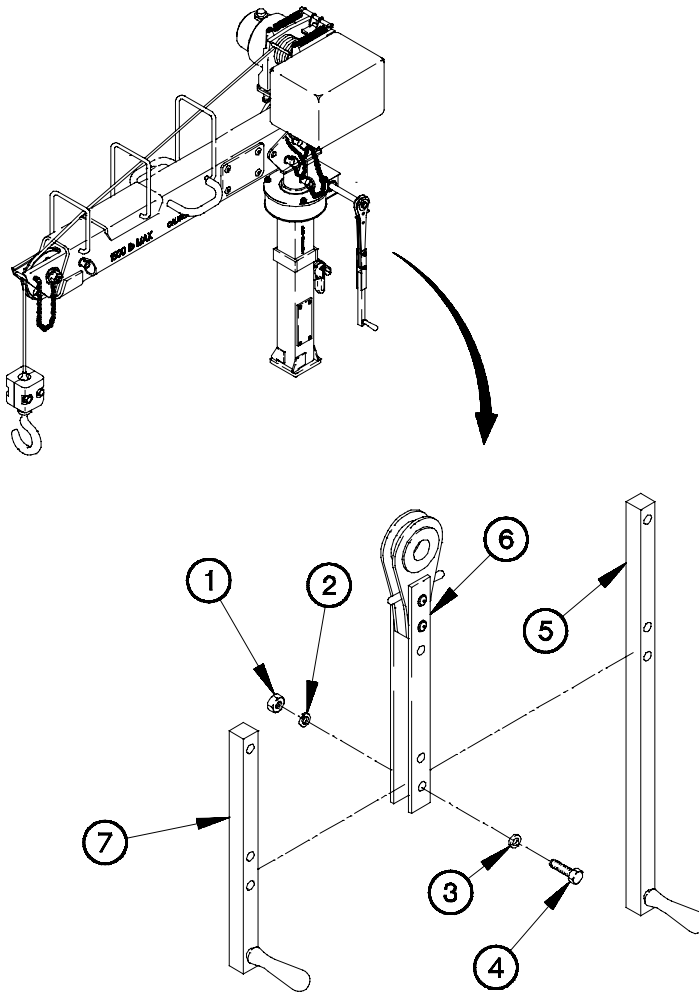
CAUTION

- If circuit breaker trips while Light Material Handling Crane (LMHC) is operating, allow 30 minutes to cool down. If load is suspended, reset circuit breaker and lower load. If circuit breaker trips again, notify Unit Maintenance. Failure to comply may result in damage to equipment.
- Do not jerk hoist control switch causing load to bounce. Failure to comply may result in damage to equipment.

- (4) Place hoist control switch (2) in down position to reel in cable (3) and lift load.
- (5) Swing boom (1) to place load in desired location (para 2-24h).
- (6) Place hoist control switch (2) in up position to lower load.
- (7) Remove hook (4) from load.

**2-24. LIGHT MATERIAL HANDLING CRANE (LMHC) OPERATION
(CONT)**

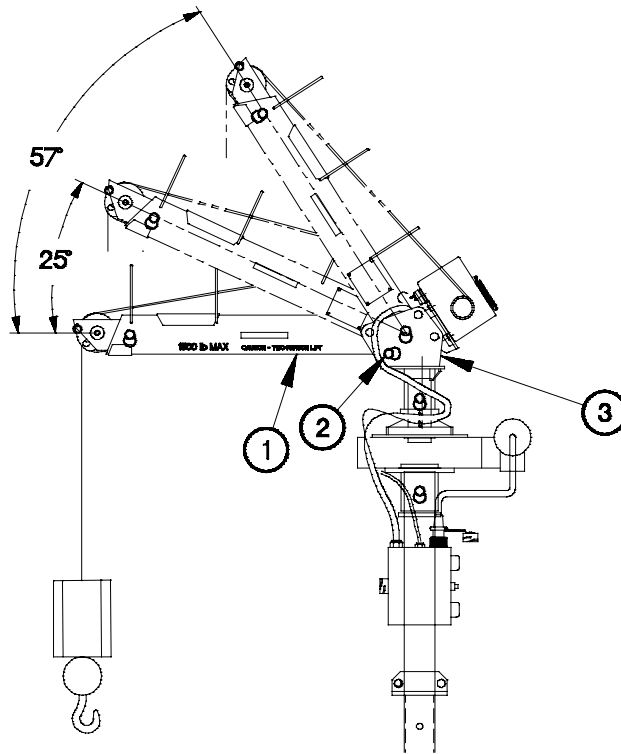
k. Installing Short Handle (if required).



1B24K011

- (1) Remove two nuts (1), lockwashers (2), washers (3), screws (4) and long handle (5) from ratchet (6).
- (2) Install short handle (7) in ratchet (6) with two washers (3), screws (4), lockwashers (2) and nuts (1).
- (3) Notify Unit Maintenance to replace lockwashers.

m. Stow LMHC.

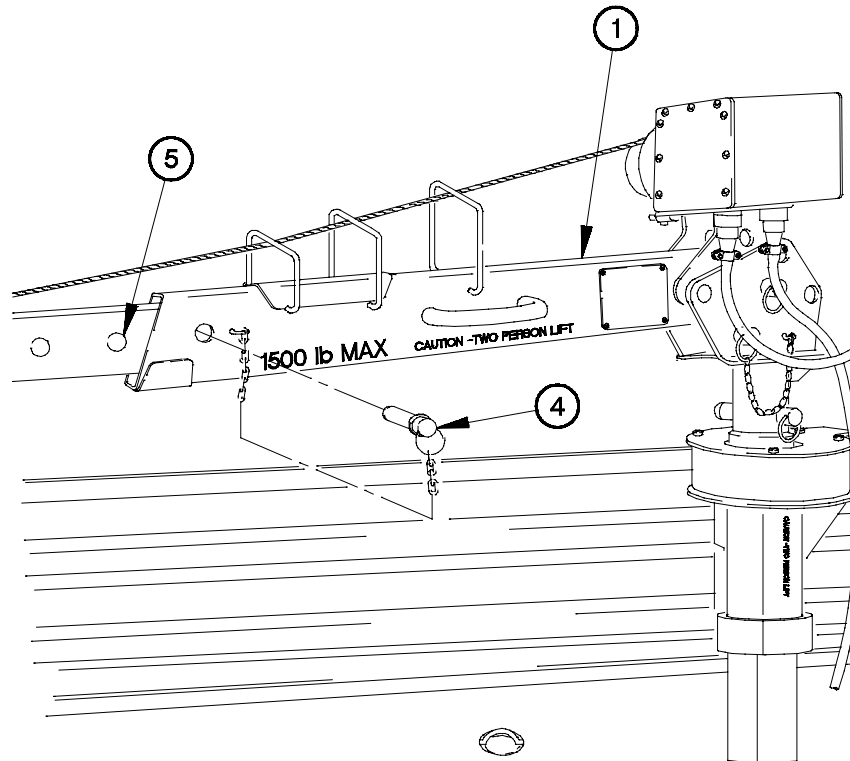


NOTE

- Steps (1) through (13) require the aid of an assistant.
- Perform steps (1) through (5) if boom was in 25-degree or 57-degree position.

- (1) Support end of boom (1).
- (2) Remove quick release pin (2) from turret (3).
- (3) Lower boom (1) to 0-degrees.
- (4) Align holes in turret (3) and boom (1).
- (5) Install quick release pin (2) in turret (3).

**2-24. LIGHT MATERIAL HANDLING CRANE (LMHC) OPERATION
(CONT)**

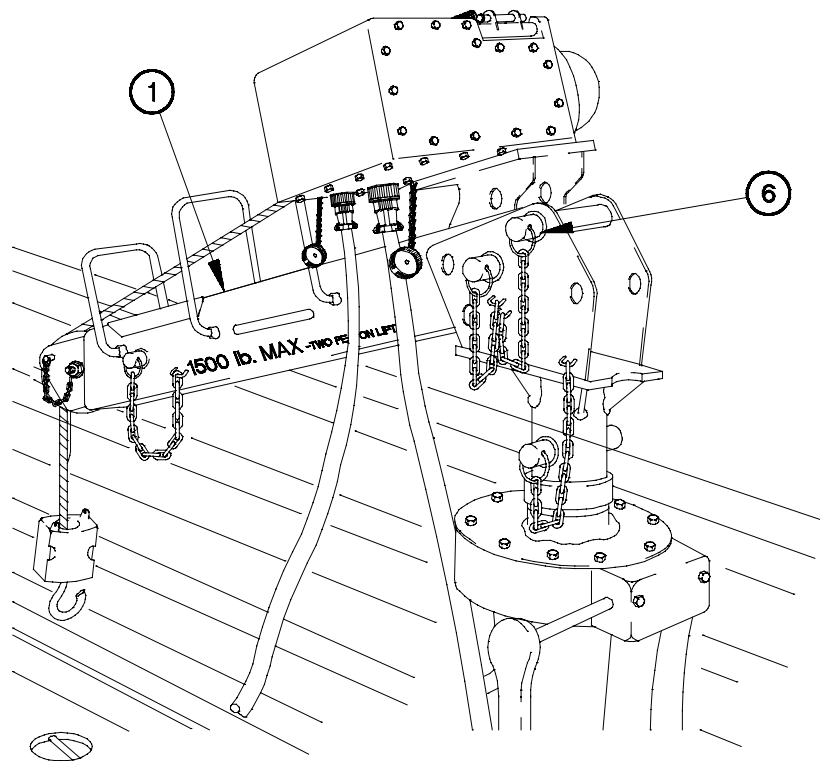


1B24M021

NOTE

Perform steps (6) through (9) if boom was extended.

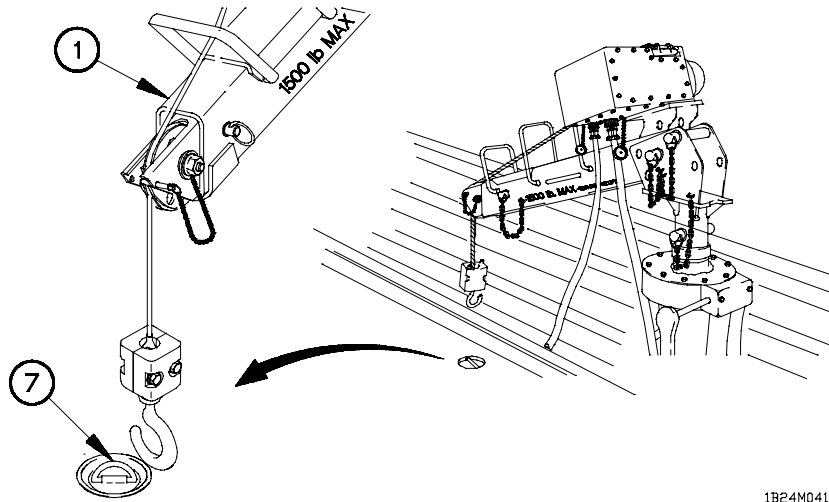
- (6) Remove quick release pin (4) from boom (1).
- (7) Push in end of boom extension (5) so that boom (1) is fully retracted.
- (8) Align holes (5) in boom (1).
- (9) Install quick release pin (4) in boom (1).



1B24M031

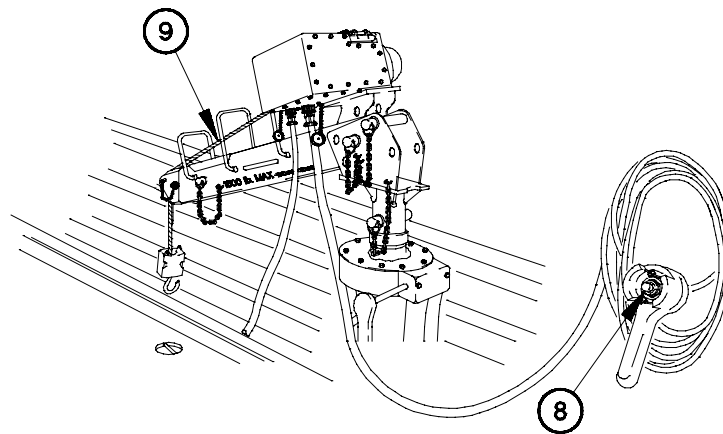
- (10) Support end of boom (1).
- (11) Remove quick release pin (6).
- (12) Lower boom (1) to stowed position.
- (13) Install quick release pin (6) in one of unused holes.

**2-24. LIGHT MATERIAL HANDLING CRANE (LMHC) OPERATION
(CONT)**



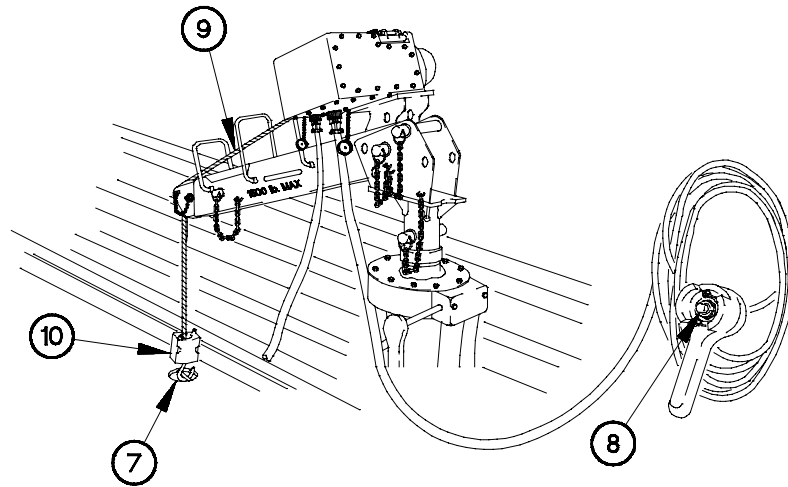
1B24M041

(14) Adjust boom (1) so that end of boom is in line with cargo bed tiedown ring (7).



1B24M051

(15) Place hoist control switch (8) in up position to pay out cable (9).



1B24M061

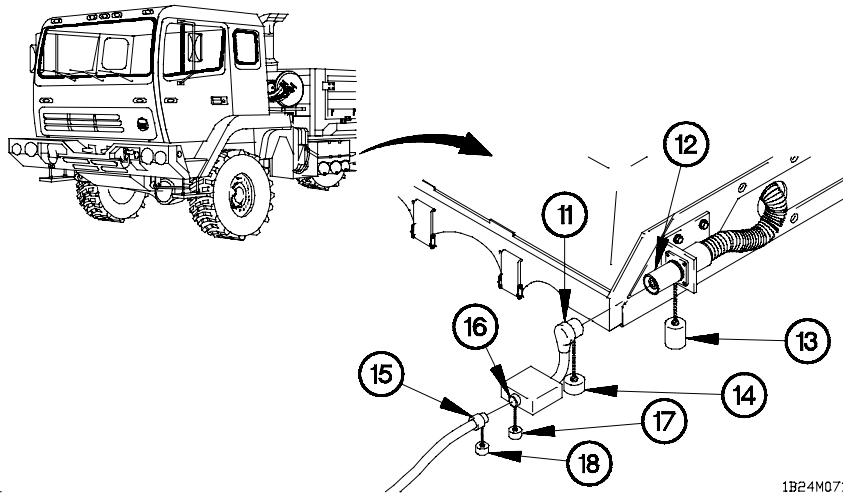
CAUTION

- Do not overtighten cable. Failure to comply may result in damage to equipment.
- Tension must be maintained on cable to prevent unraveling from spool. Failure to comply may result in damage to equipment.

(16) Connect hook (10) to cargo bed tiedown ring (7).

(17) Place hoist control switch (8) in down position to remove slack from cable (9).

**2-24. LIGHT MATERIAL HANDLING CRANE (LMHC) OPERATION
(CONT)**



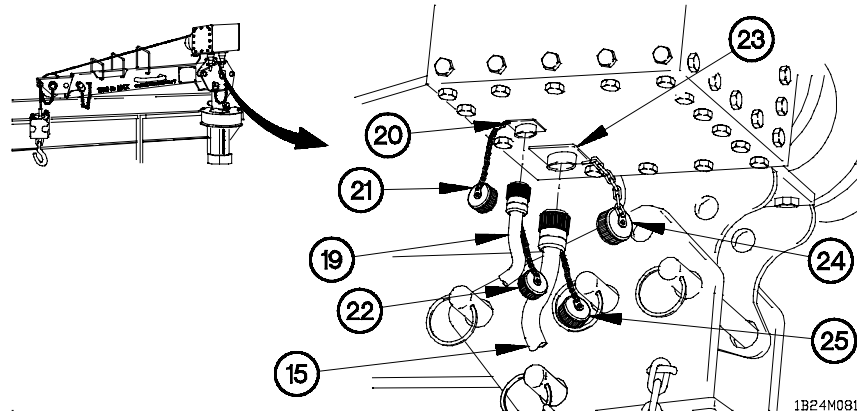
WARNING

Ensure that engine is not running before disconnecting circuit breaker box NATO connector at vehicle NATO connector. Failure to comply may result in serious injury or death to personnel.

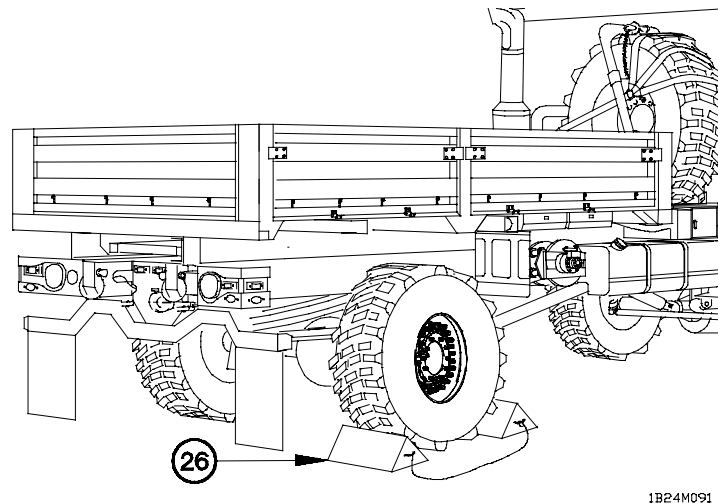
CAUTION

Ensure that power cable does not come in contact with exhaust pipe. Failure to comply may result in damage to equipment.

- (18) Disconnect circuit breaker box NATO connector (11) from vehicle NATO connector (12).
- (19) Install dust cap (13) on vehicle NATO connector (12).
- (20) Install dust cap (14) on circuit breaker box NATO connector (11).
- (21) Disconnect power cable connector (15) from circuit breaker box NATO connector (16).
- (22) Install dust cap (17) on circuit breaker box NATO connector (16).
- (23) Install dust cap (18) on power cable connector (15).



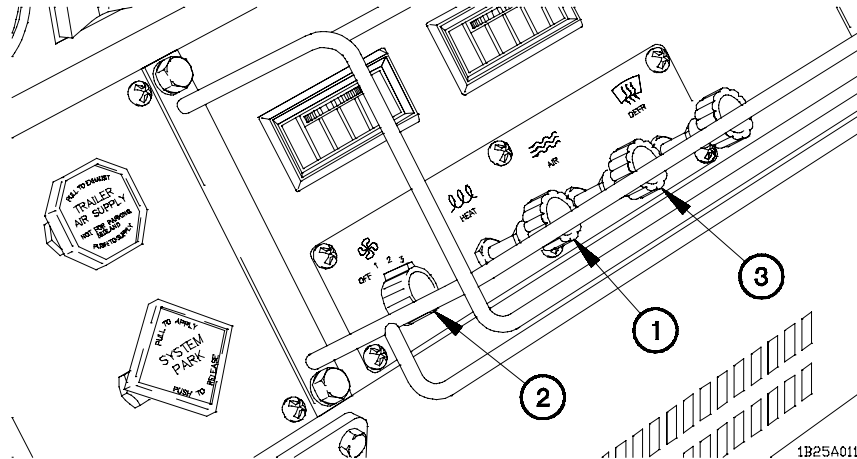
- (24) Disconnect remote control connector (19) from winch remote control connector (20).
- (25) Install dust cap (21) on winch remote control connector (20).
- (26) Install dust cap (22) on remote control connector (19).
- (27) Disconnect power cable connector (15) from winch power cable connector (23).
- (28) Install dust cap (24) on winch power cable connector (23).
- (29) Install dust cap (25) on power cable connector (15).



- (30) Remove wheel chocks (26) from rear wheels.

2-25. HEATER/DEFROST OPERATION

a. Operate Cab Heat.

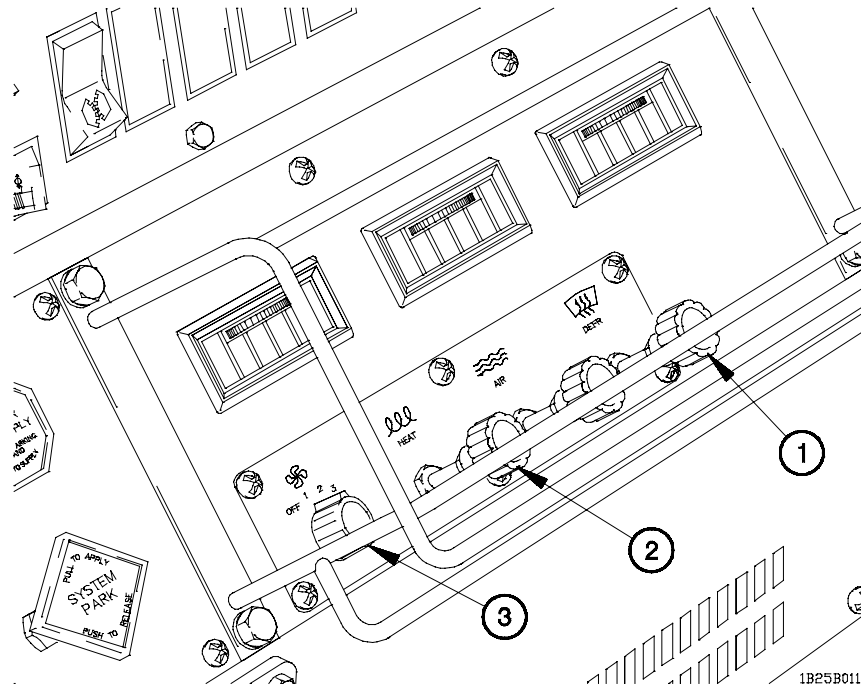


NOTE

Heat output increases as HEAT control is pulled farther out.

- (1) Pull HEAT control (1) to desired setting.
- (2) Position FAN switch (2) to desired speed.
- (3) Pull AIR control (3) to allow outside air to enter cab for ventilation.
- (4) Push in AIR control (3) to stop flow of outside air.
- (5) Push in HEAT control (1) to turn off heat.
- (6) Position FAN switch (2) to OFF to turn off fan.

b. Operate Windshield Defrost.



NOTE

The amount of air directed to cab windshield increases as DEFROST control is pulled farther out.

- (1) Pull DEFROST control (1) outward to desired position.

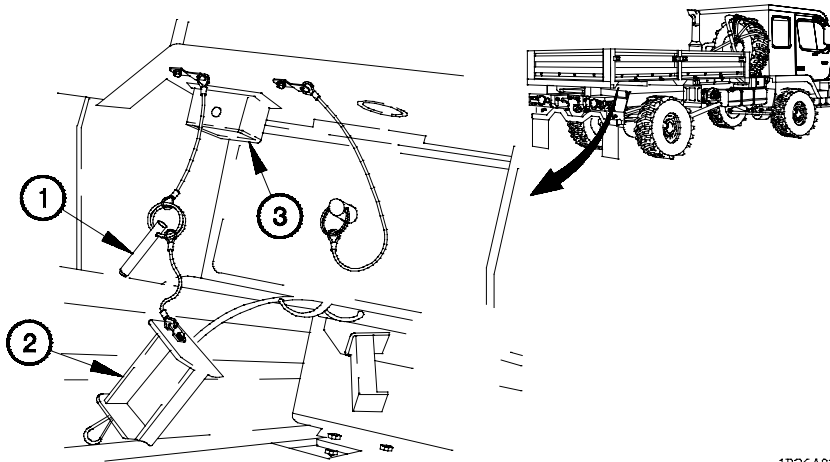
NOTE

Temperature of air output directed to windshield increases as HEAT control is pulled farther out.

- (2) Pull HEAT control (2) to desired position.
- (3) Position FAN switch (3) to desired speed.
- (4) Push in HEAT control (2) to turn heat off.
- (5) Position FAN switch (3) to OFF to turn fan off.
- (6) Push in DEFROST control (1) to stop directing air on windshield.

2-26. LADDER, SIDE PANELS, AND STAKES OPERATION

a. Lower Ladder.

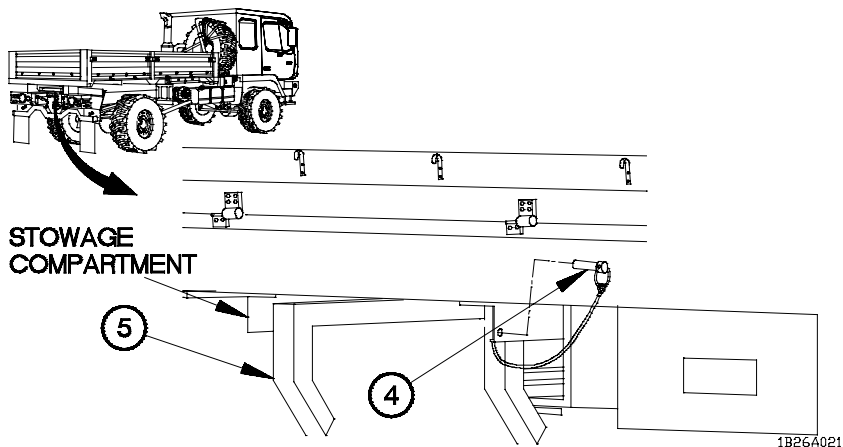


1B26A011

CAUTION

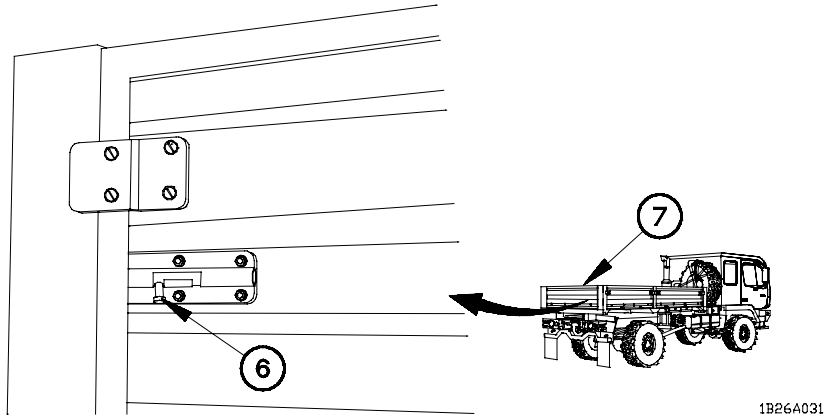
Do not use gladhands as a step to access cargo bed. Failure to comply may result in damage to equipment.

- (1) Remove two pins (1) and ladder plugs (2) from ladder mounting holes (3).

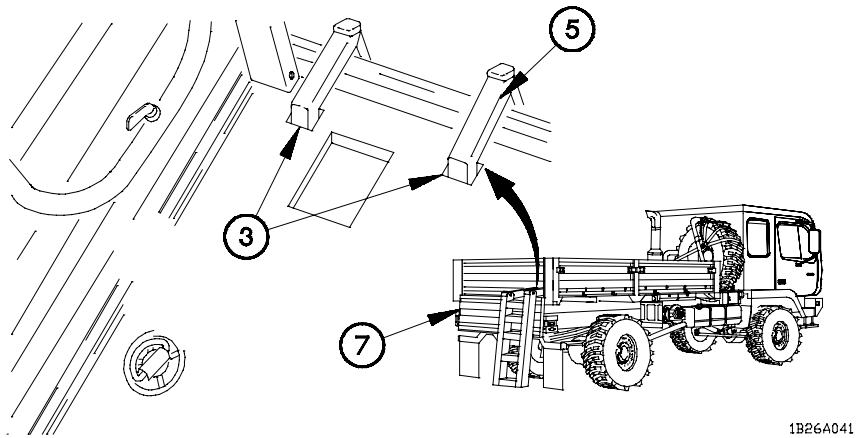


1B26A021

- (2) Remove ladder locking pin (4) from ladder (5).
- (3) Remove ladder (5) from ladder stowage compartment.



(4) Unlatch two latches (6) from tailgate (7).

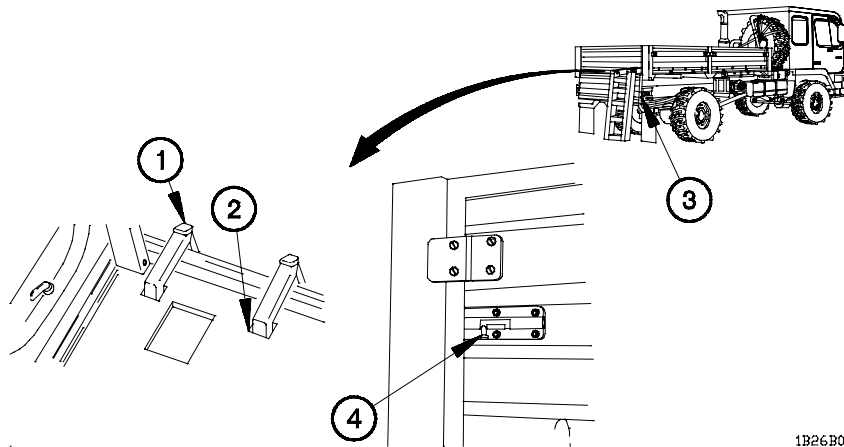


(5) Lower tailgate (7).

(6) Mount ladder (5) in two ladder mounting holes (3).

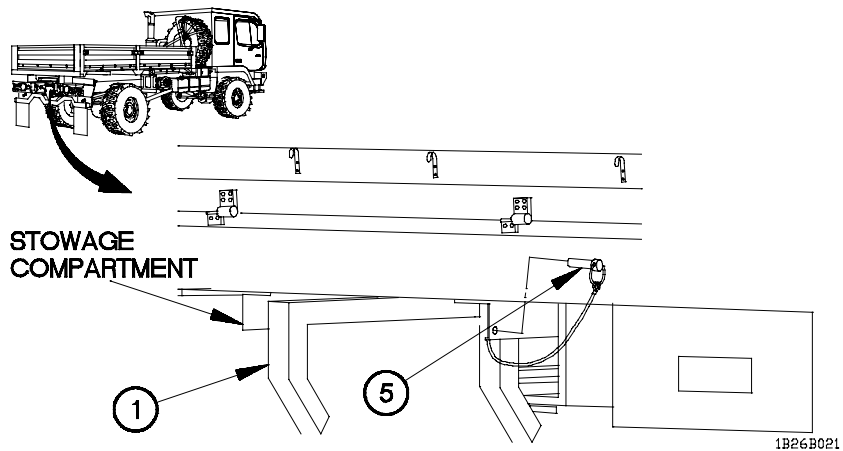
2-26. LADDER, SIDE PANELS, AND STAKES OPERATION (CONT)

b. Stow Ladder.



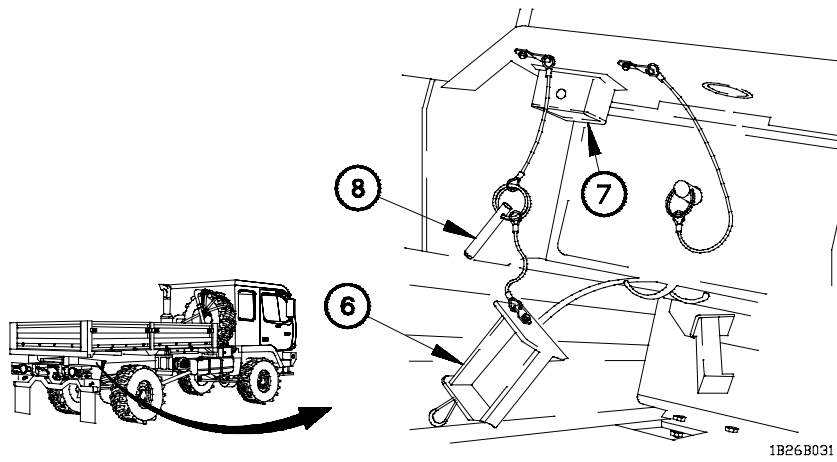
1B26B011

- (1) Remove ladder (1) from two ladder mounting holes (2).
- (2) Raise tailgate (3) and fasten two latches (4).



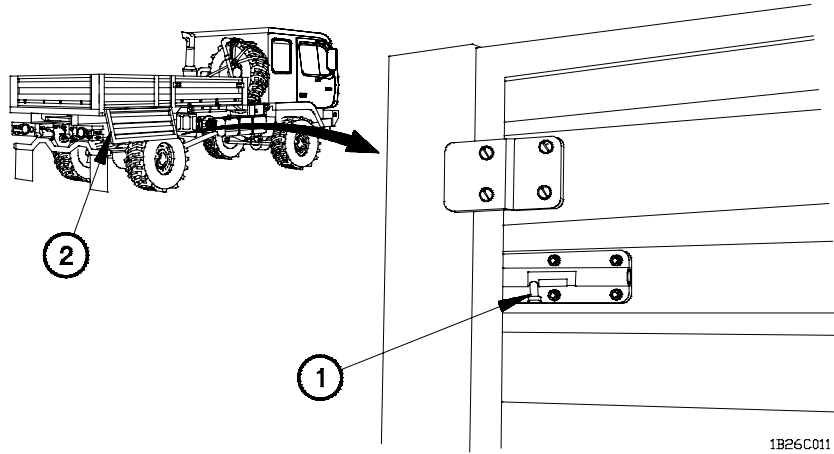
1B26B021

- (3) Install ladder (1) in ladder stowage compartment.
- (4) Install locking pin (5) in ladder (1).



(5) Install two ladder plugs (6) in ladder mounting holes (7) with two pins (8).

c. Lower Cargo Bed Side Panel.

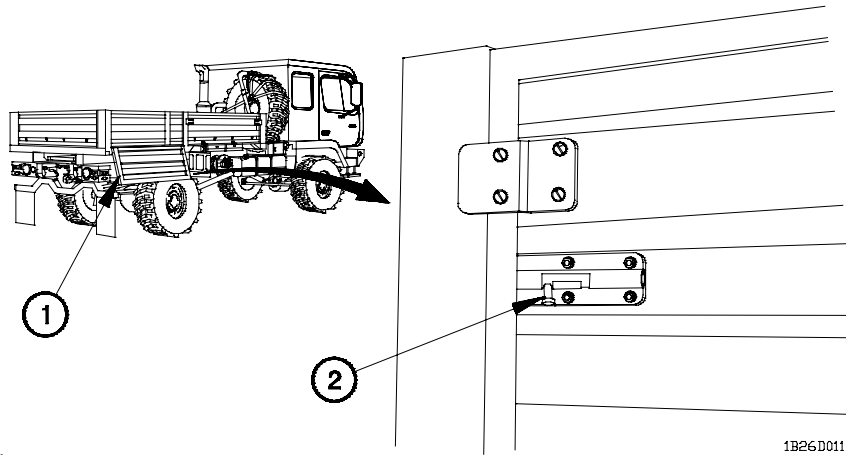


(1) Unlock two latches (1) and lower cargo bed side panel (2).

(2) Repeat step (1) for remaining cargo bed side panel (2) as required.

2-26. LADDER, SIDE PANELS, AND STAKES OPERATION (CONT)

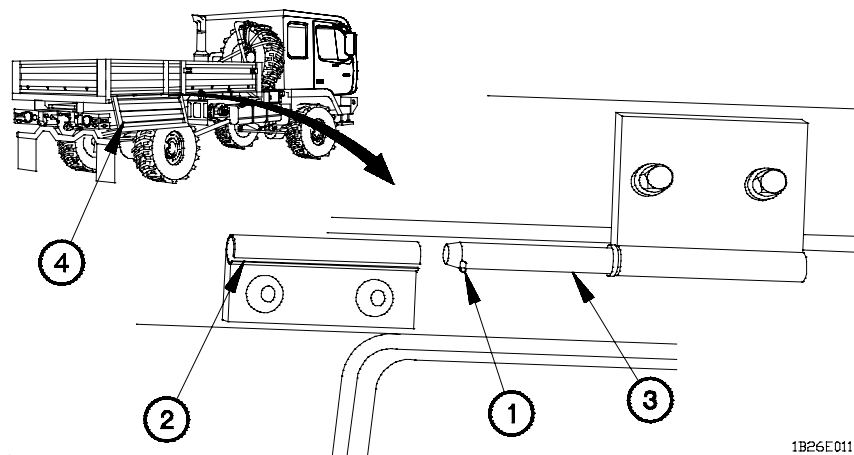
d. Raise Cargo Bed Side Panel.



(1) Raise cargo bed side (1) and latch two latches (2).

(2) Repeat step (1) for remaining cargo bed side panels (1) as required.

e. Remove Cargo Bed Side Panel.

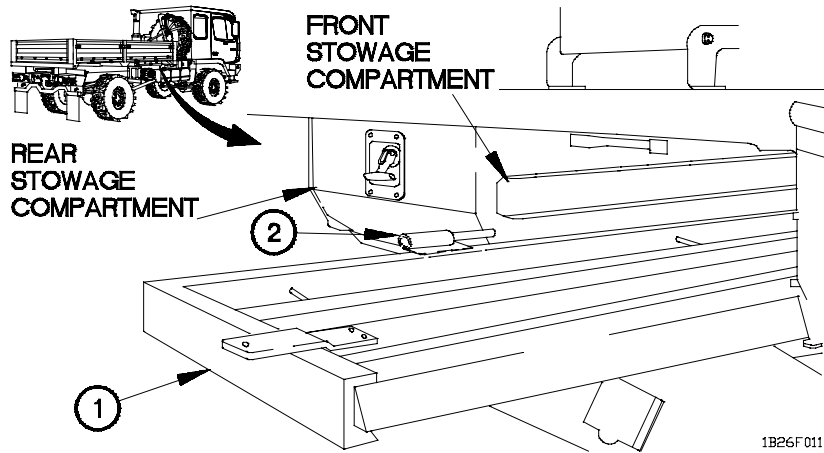


(1) Lower cargo bed side panel (para 2-26c).

(2) Align pin (1) with slot in lower hinge half (2).

(3) Slide hinge shaft (3) out of lower hinge half (2) and remove cargo bed side panel (4) from vehicle.

f. Stow Cargo Bed Side Panels.



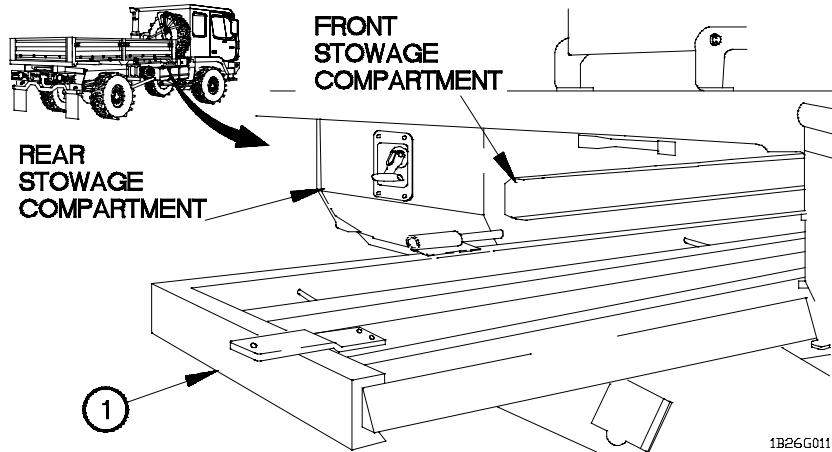
- (1) Stow cargo bed side panel (1) in cargo bed stowage compartment with hinges (2) facing up refer to **Table 2-7. Cargo Bed Side Panel Stowage Information.**
- (2) Repeat step (1) as required for remaining sides.

Table 2-7. Cargo Bed Side Panel Stowage Information

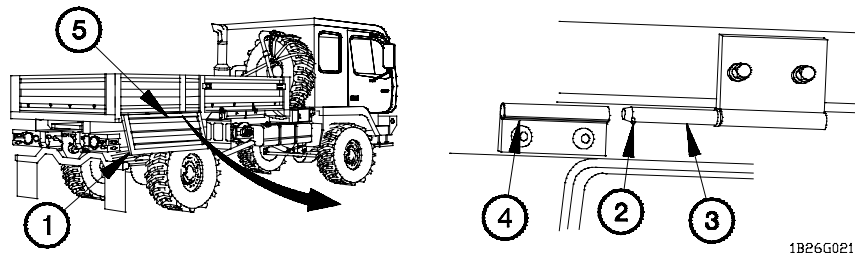
Cargo Bed Side Panel Stowed	Stowage Compartment Used	Position of Cargo Bed Side	Shelf Used to Stow Cargo Bed Side
1st side stowed	Front	Hinges on left side of panel	Bottom shelf
2nd side stowed	Front	Hinges on right side of panel	Middle shelf
3rd side stowed	Front	Hinges on right side of panel	Top shelf
4th side stowed	Rear	Hinges on left side of panel	Top shelf
Tailgate stowed	Rear	Hinges on left side of panel	Middle shelf

2-26. LADDER, SIDE PANELS, AND STAKES OPERATION (CONT)

g. Install Cargo Bed Side Panels.

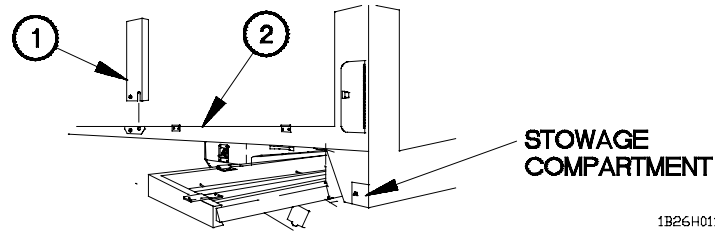


- (1) Remove cargo bed side panel (1) from cargo bed stowage compartment.



- (2) Align pin (2) on hinge shaft (3) with slot in lower hinge half (4).
- (3) Install cargo bed side panel (1) on cargo bed (5) by sliding hinge shaft (3) into lower hinge half (4).
- (4) Raise cargo bed side panel (para 2-26d).
- (5) Repeat steps (1) through (4) for remaining cargo bed side panels (1) as required.

h. Cargo Bed Stake Removal.

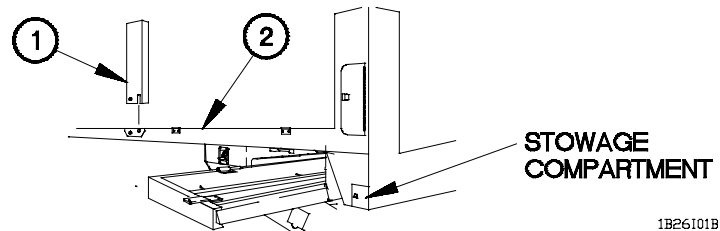


NOTE

Perform steps (1) through (3) on vehicles serial number 0001 through 7411.

- (1) Remove cargo bed stake (1) from cargo bed (2).
- (2) Place cargo bed stake (1) in stowage compartment.
- (3) Perform steps (1) and (2) on remaining cargo bed stakes.

i. Cargo Bed Stake Installation.



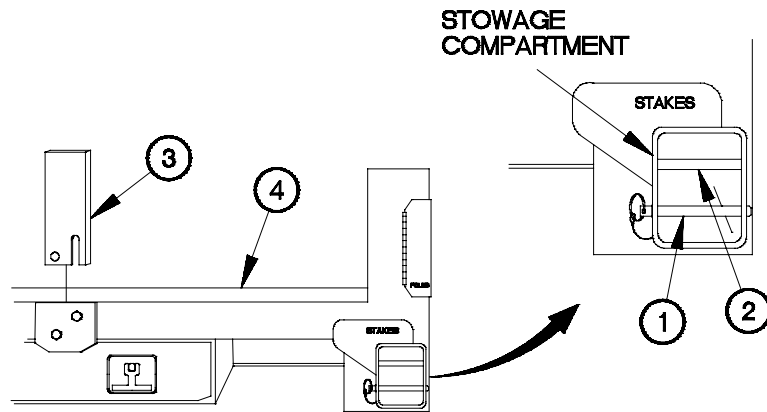
NOTE

Perform steps (1) through (3) on vehicle serial number 0001 through 7411.

- (1) Remove cargo bed stake (1) from stowage compartment.
- (2) Install cargo bed stake (1) in cargo bed (2).
- (3) Perform steps (1) and (2) on remaining cargo bed stakes.

2-26. LADDER, SIDE PANELS, AND STAKES OPERATION (CONT)

j. Cargo Bed Stake Removal.



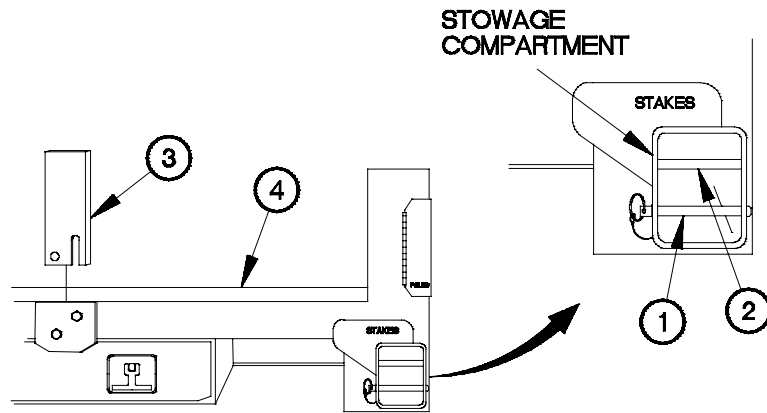
1B26J01B

NOTE

Perform steps (1) through (5) on vehicle serial number 7412 and higher.

- (1) Remove detent pins (1 and 2) from stowage compartment.
- (2) Remove cargo bed stake (3) from cargo bed (4).
- (3) Place cargo bed stake (3) in stowage compartment.
- (4) Perform steps (2) and (3) on remaining cargo bed stakes.
- (5) Install detent pins (1 and 2) in stowage compartment.

k. Cargo Bed Stake Installation.



1B26K01B

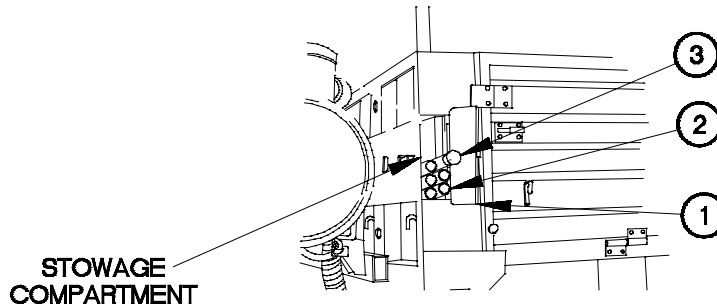
NOTE

Perform steps (1) through (5) on vehicle serial number 7412 and higher.

- (1) Remove detent pins (1 and 2) from stowage compartment.
- (2) Remove cargo bed stake (3) from stowage compartment.
- (3) Install cargo bed stake (3) in cargo bed (4).
- (4) Perform steps (2) and (3) on remaining cargo bed stakes.
- (5) Install detent pins (1 and 2) in stowage compartment.

2-27. CARGO COVER KIT INSTALLATION/REMOVAL

a. Soft Top Kit (Steel Bows) Installation.



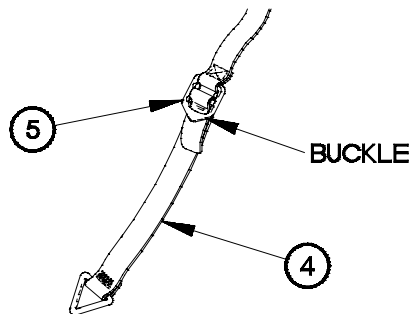
1B27A01B

- (1) Lower ladder (para 2-26a).
- (2) Open stowage compartment door (1).

NOTE

Soft top kit is equipped with a total of 10 tubes. Five front tubes are longer than rear tubes.

- (3) Stow five front tubes (2) and steel pole (3) in stowage compartment.
- (4) Close stowage compartment door (1).



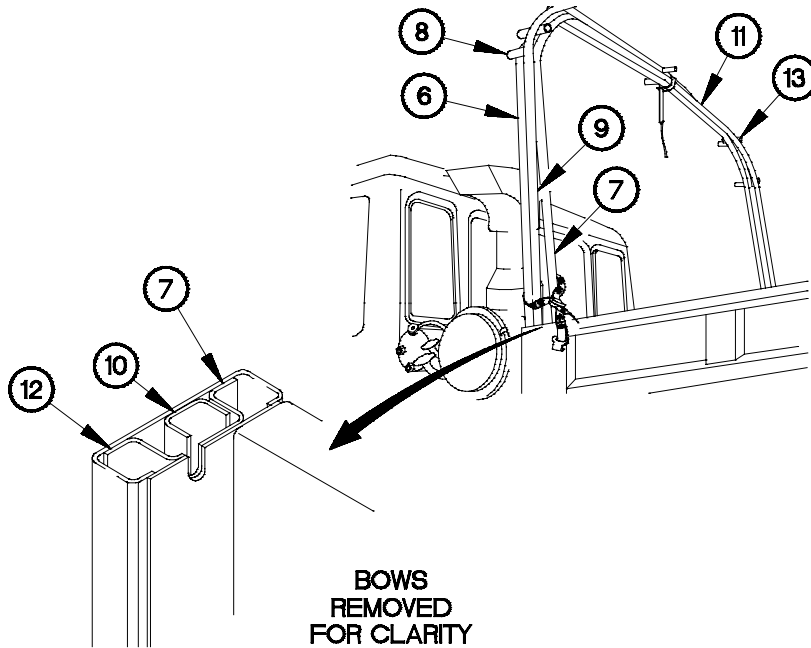
1B27A02B

NOTE

Front, center, and rear bows have two bow straps and tiedown straps. All tiedown straps are installed on bow straps the same way. One tiedown strap shown.

- (5) Install tiedown strap (4) through buckle of bow strap (5).
- (6) Perform step (5) on remaining tiedown straps.

2-27. CARGO COVER KIT INSTALLATION/REMOVAL (CONT)

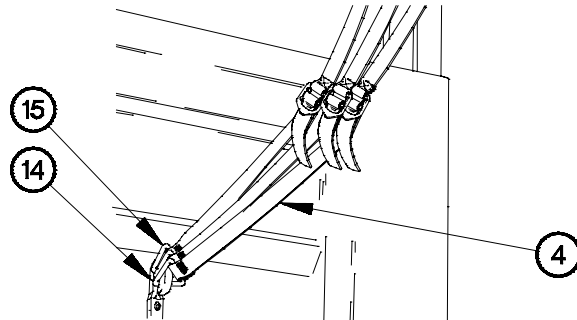


16276036

NOTE

Steps (7) through (9) require the aid of an assistant.

- (7) Position front bow (6) in front cargo bed pockets (7) with front bow brackets (8) toward front of vehicle.
- (8) Position center bow (9) in middle cargo bed pockets (10).
- (9) Position rear bow (11) in rear cargo bed pockets (12) with rear bow brackets (13) toward rear of vehicle.

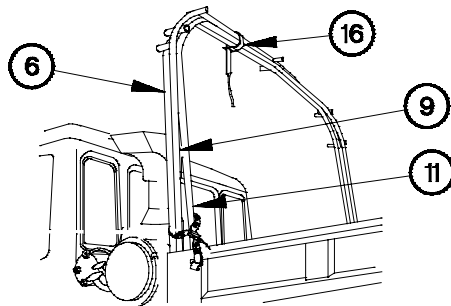


1B27A04B

NOTE

Left and right sides of front, center, and rear bows are secured the same way. Right side shown.

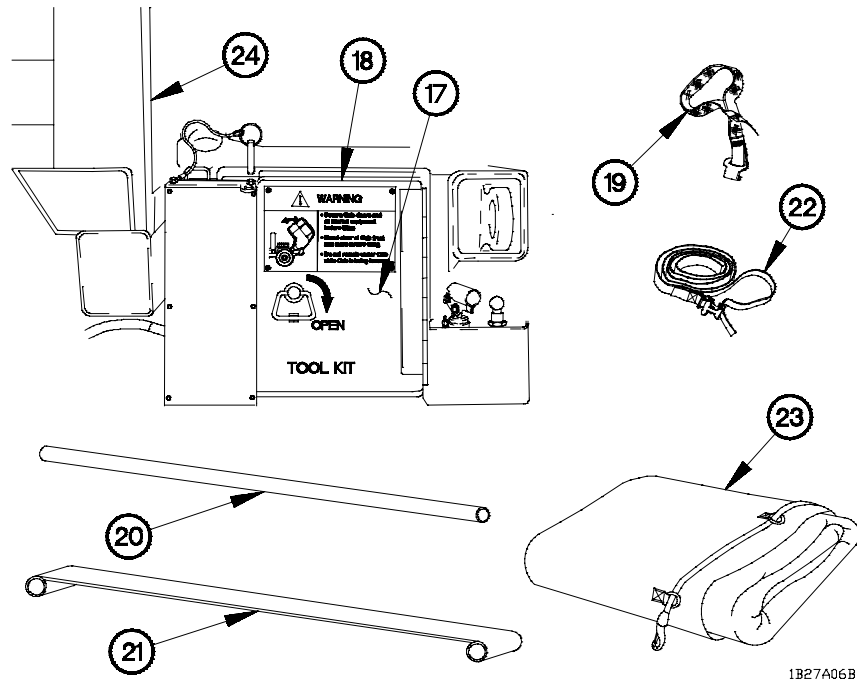
- (10) Position three tiedown straps (4) on J-hook (14) with three tri-rings (15).
- (11) Tighten three tiedown straps (4).
- (12) Perform steps (10) and (11) on left side.



1B27A05B

- (13) Install stowage strap (16) on front bow (6), center bow (9), and rear bow (11).

2-27. CARGO COVER KIT INSTALLATION/REMOVAL (CONT)



- (14) Open door (17) on tool box (18).
- (15) Stow three cargo cover tiedowns (19) in tool box (18).
- (16) Close door (17) on tool box (18).

WARNING

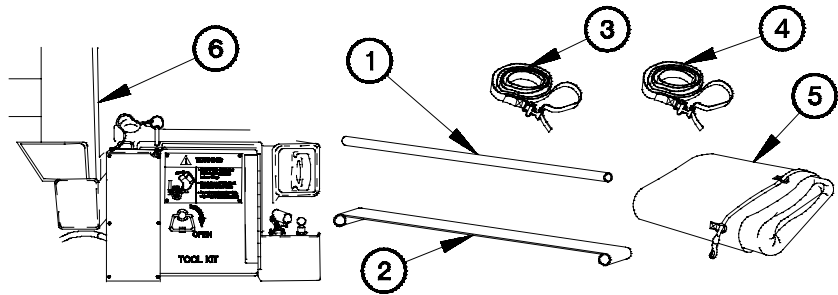
Cargo cover weighs approximately 60 lbs (27 kgs). An assistant is required to lift cargo cover. Failure to comply may result in injury to personnel or damage to equipment.

NOTE

Step (17) requires the aid of an assistant.

- (17) Stow five rear tubes (20), four braces (21), two strap supports (22), and cargo cover (23) on cargo bed (24).
- (18) Stow ladder (para 2-26b).

b. Soft Top (Steel Bows) Installation.



1B27B01B

- (1) Lower ladder (para 2-26a).
- (2) Lower spare tire (para 3-5).

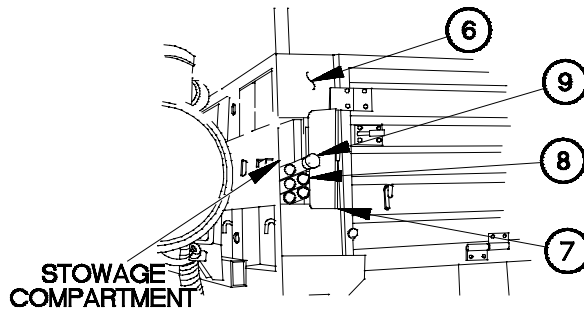
WARNING

Cargo cover weighs approximately 60 lbs (27 kgs). An assistant is required to lift cargo cover. Failure to comply may result in injury to personnel or damage to equipment.

NOTE

Step (3) requires the aid of an assistant.

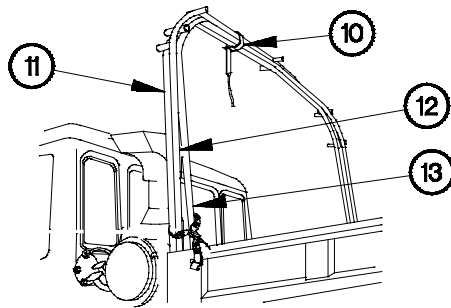
- (3) Remove rear five tubes (1), four braces (2), left strap support (3), right strap support (4), and cargo cover (5) from cargo bed (6).



1B27B02B

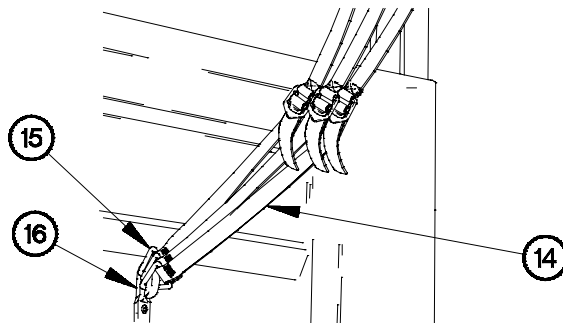
- (4) Open stowage compartment door (7).
- (5) Remove five front tubes (8) and steel pole (9) from stowage compartment.
- (6) Close stowage compartment door (7).

2-27. CARGO COVER KIT INSTALLATION/REMOVAL (CONT)



1B27B03B

- (7) Remove stowage strap (10) from front bow (11), center bow (12), and rear bow (13).

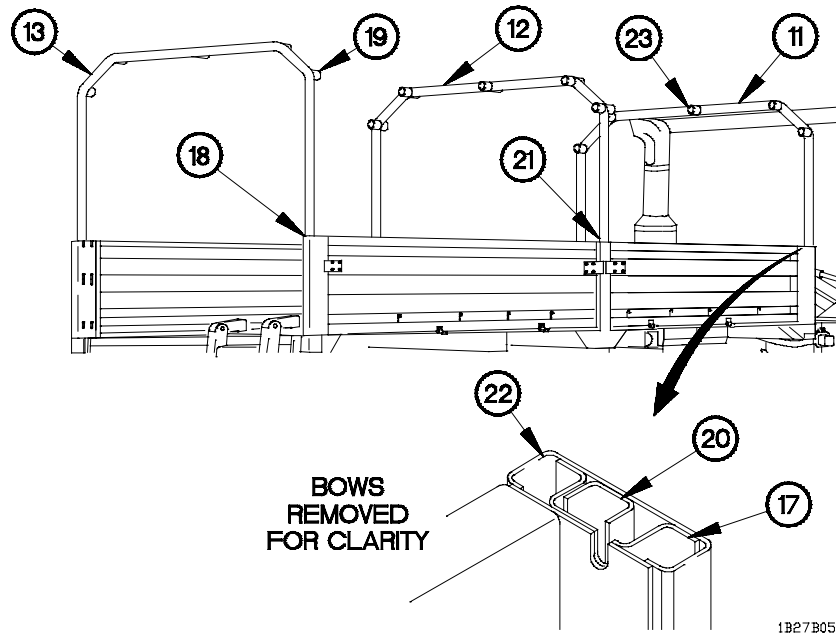


1B27B04B

NOTE

Left and right sides of front, center, and rear bows are released the same way. Right side shown.

- (8) Loosen three tiedown straps (14).
- (9) Remove three tri-rings (15) on tiedown straps (14) from J-hook (16).
- (10) Perform steps (8) and (9) on left side.

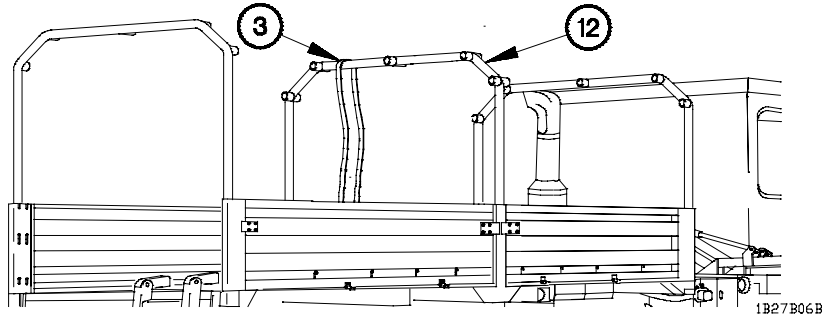


NOTE

Steps (11) through (16) require the aid of an assistant.

- (11) Remove rear bow (13) from rear cargo bed pockets (17).
- (12) Position rear bow (13) in rear pockets of rear cargo bed stakes (18) with rear bow brackets (19) toward front of vehicle.
- (13) Remove center bow (12) from center cargo bed pockets (20).
- (14) Position center bow (12) in rear pockets of center cargo bed stakes (21).
- (15) Remove front bow (11) from front cargo bed pockets (22).
- (16) Position front bow (11) in front cargo bed pockets (22) with front bow brackets (23) toward rear of vehicle.

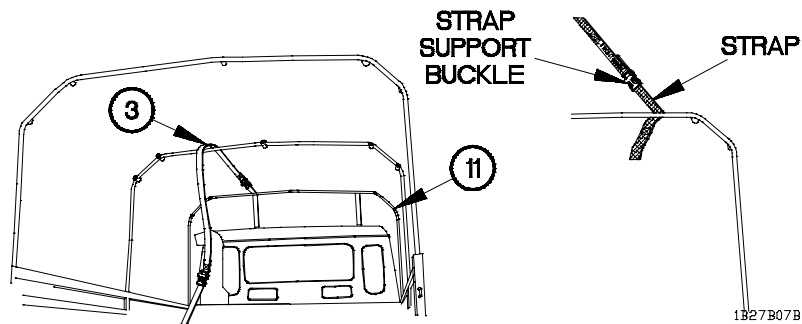
2-27. CARGO COVER KIT INSTALLATION/REMOVAL (CONT)



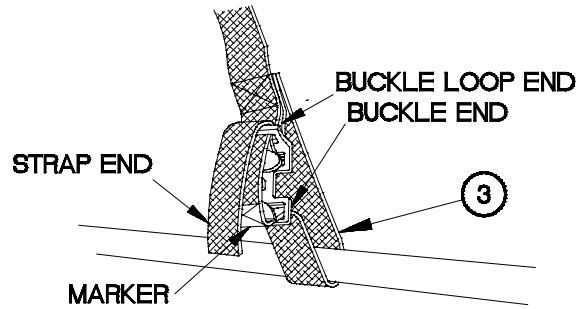
NOTE

- Strap support is marked with FRONT and an arrow to indicate front bottom of strap support.
- Strap supports are to be centered between center bow brackets and left and right inside of bow brackets.
- Left and right strap supports are installed the same way. Left strap support shown.

(17) Position left strap support (3) over center bow (12).



(18) Position left strap support (3) around front bow (11) and through strap support buckle.



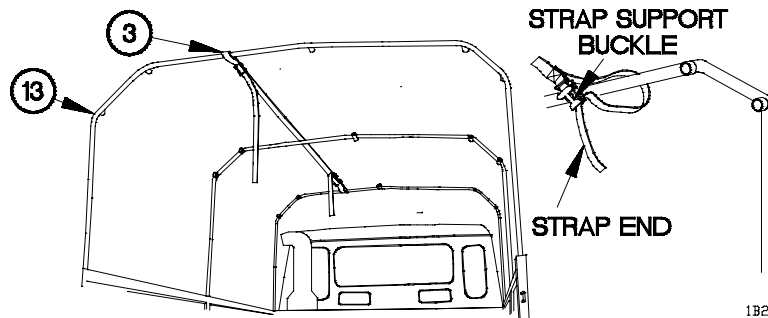
1B27B08B

- (19) Tighten left strap support (3) until marker is through the buckle end.

CAUTION

Strap end must be installed in the buckle loop end after strap is tightened. Failure to comply may result in damage to equipment.

- (20) Install strap end through buckle loop end on left strap support (3).

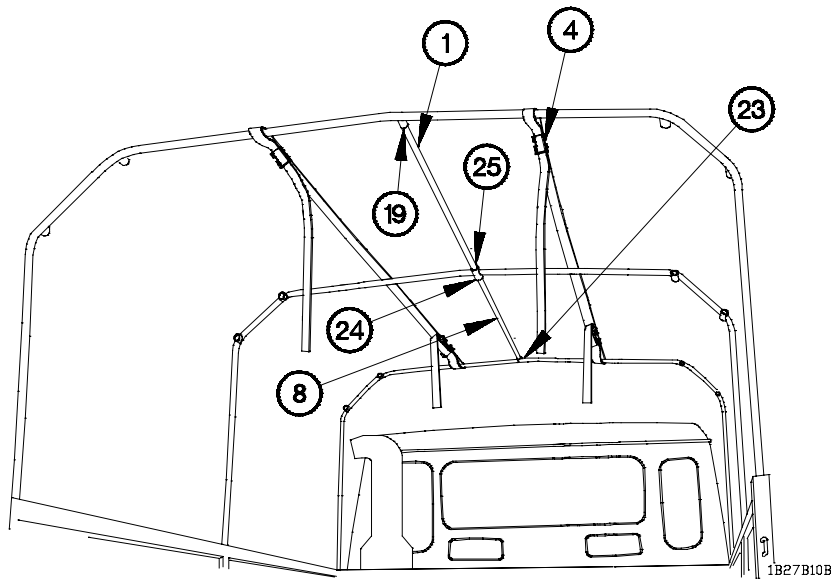


1B27B09B

- (21) Position left strap support (3) around rear bow (13) and through strap support buckle.

- (22) Perform steps (17) through (21) on right strap support.

2-27. CARGO COVER KIT INSTALLATION/REMOVAL (CONT)



NOTE

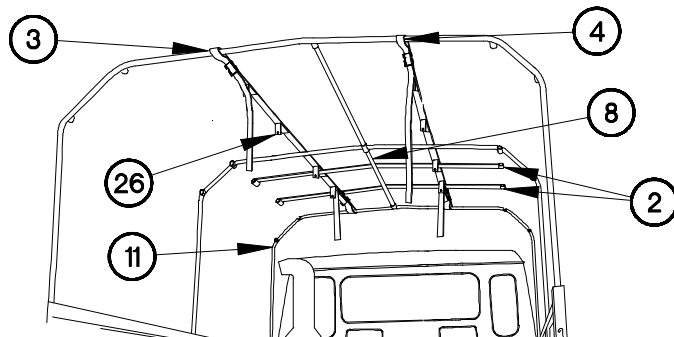
Steps (23) through (25) require the aid of an assistant.

- (23) Install front tube (8) in front bow bracket (23) and center bow bracket (24).
- (24) Install rear tube (1) in center bow bracket (25) and rear bow bracket (19).

CAUTION

Strap supports must be aligned straight between front bow and rear bow. Failure to comply may result in damage to equipment.

- (25) Tighten right rear strap support (4).



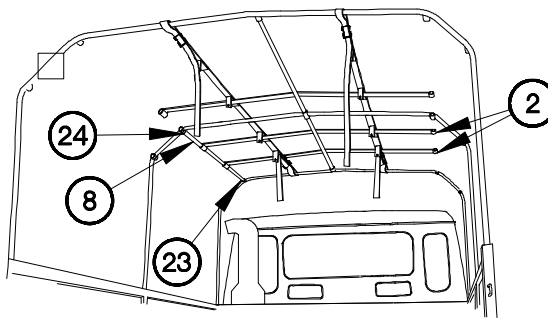
1B27B11B

NOTE

Left and right strap supports have six flaps. From front to rear of vehicle, perform step (26) on first, second, third, and fifth straps on each strap support.

(26) Open four flaps (26) on left strap support (3) and right strap support (4).

Position two braces (2) over front tube (8) and under left strap support (3) and right strap support (4) with approximately two feet (0.6 m) between front bow (11) and each brace (2).



1b27b14b

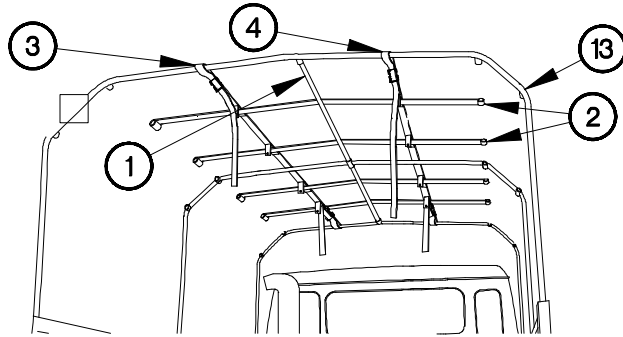
NOTE

- Left and right tubes are installed the same way. Left side tubes shown.
- Steps (28) through (36) require the aid of an assistant.

(28) Position front tube (8) through two braces (2).

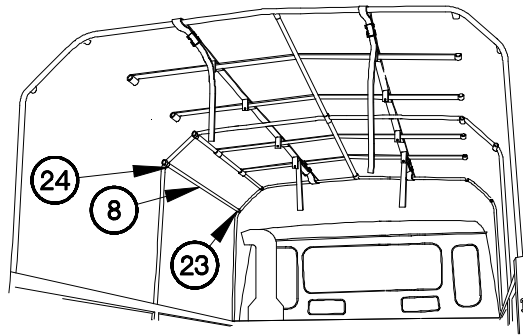
(29) Install front tube (8) in front bow bracket (23) and center bow bracket (24).

2-27. CARGO COVER KIT INSTALLATION/REMOVAL (CONT)



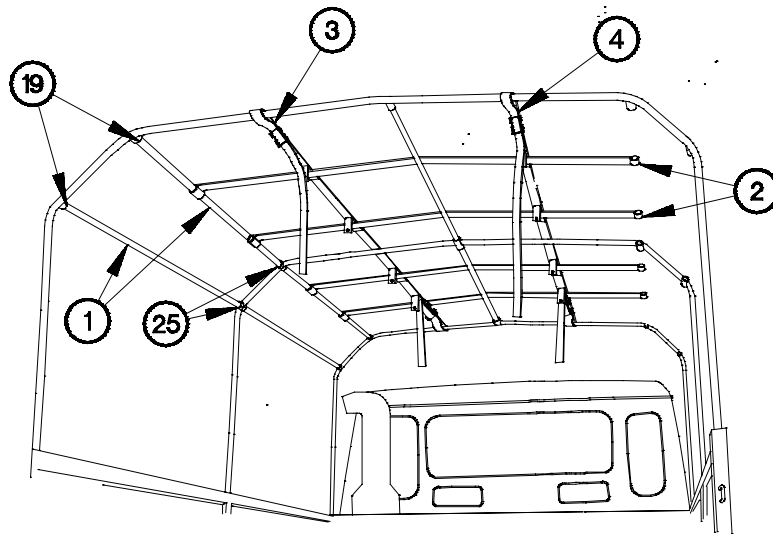
1B27B12B

- (30) Position two braces (2) over rear tube (1) and under left strap support (3) and right strap support (4) with approximately 2 feet (0.6 m) between rear bow (13) and each brace (2).



1B27B13B

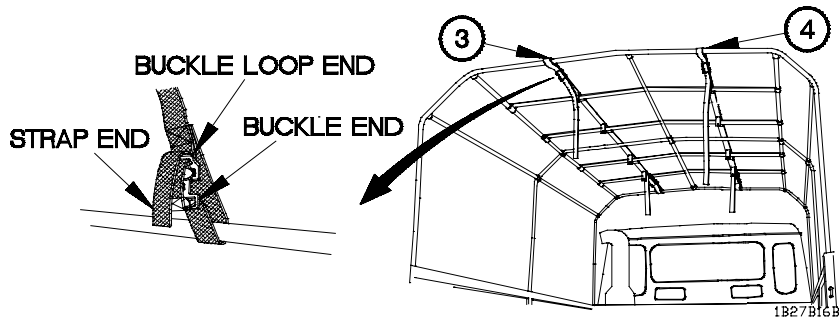
- (31) Install front tube (8) in front bow bracket (23) and center bow bracket (24).



1B27B15B

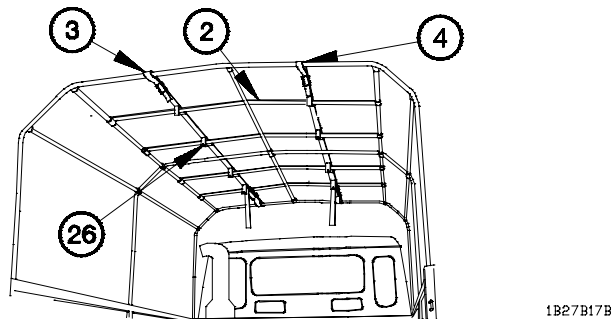
- (32) Install rear tube (1) in rear bow bracket (19) and center bow bracket (25).
- (33) Position rear tube (1) through two braces (2).
- (34) Install rear tube (1) in rear bow bracket (19) and center bow bracket (25).
- (35) Tighten left rear strap support (3).
- (36) Loosen right rear strap support (4).
- (37) Perform steps (29) through (34) on right side tubes.

2-27. CARGO COVER KIT INSTALLATION/REMOVAL (CONT)



(38) Tighten right rear strap support (4).

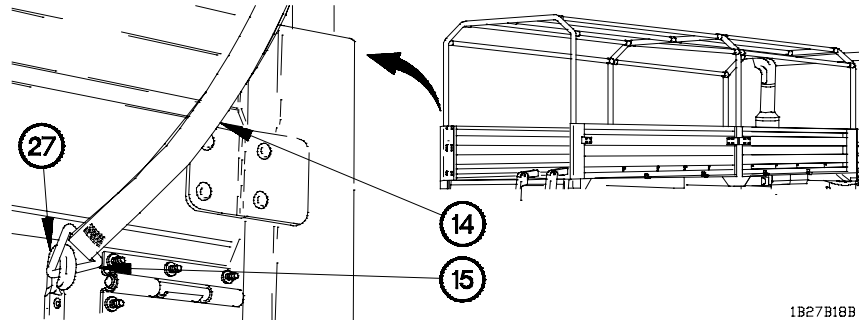
(39) Install two strap ends through buckle loop ends on left strap support (3) and right strap support (4).



NOTE

Adjust braces as needed to snap and attach flaps over braces.

(40) Close four flaps (26) over four braces (2) on left strap support (3) and right strap support (4).

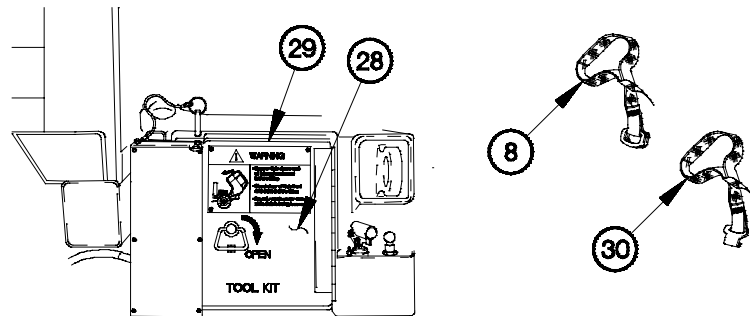


1B27B18B

NOTE

Left and right sides of front, center, and rear bows are secured the same way. Rear bow left side shown.

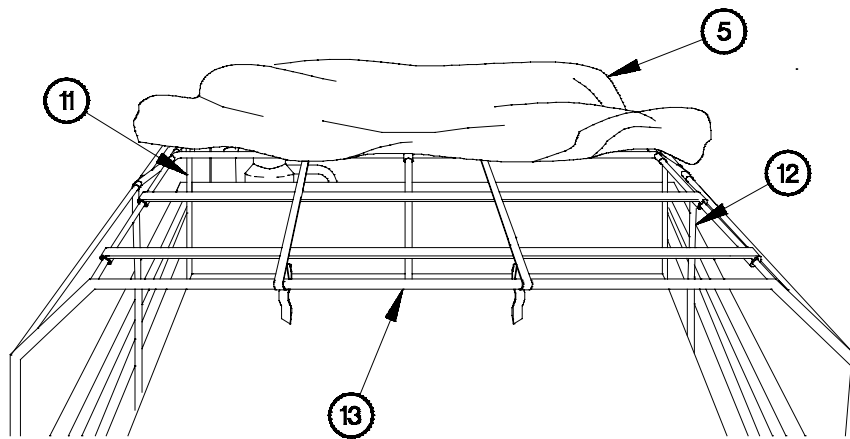
- (41) Position tiedown strap (14) on J-hook (27) with tri-ring (15).
- (42) Tighten tiedown strap (14).
- (43) Perform steps (41) and (42) on remaining tiedown straps.



1B27B19B

- (44) Open door (28) on tool box (29).
- (45) Remove three cargo cover tiedowns (30) from tool box (29).
- (46) Stow stowage strap (8) in tool box (29).
- (47) Close door (28) on tool box (29).

2-27. CARGO COVER KIT INSTALLATION/REMOVAL (CONT)



1B27B20B

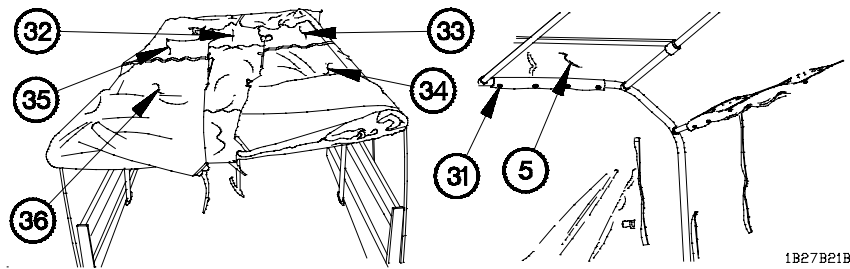
WARNING

Cargo cover weighs approximately 60 lbs (27 kgs). An assistant is required to lift cargo cover. Failure to comply may result in injury to personnel or damage to equipment.

NOTE

- Steps (48) through (71) require the aid of an assistant.
- Cargo cover is marked with FRONT on the front flap.

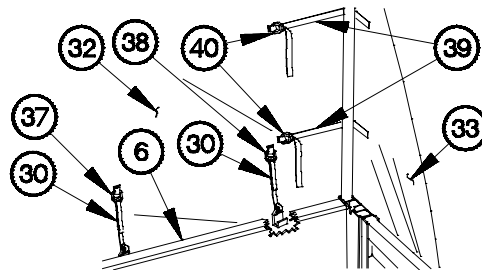
(48) Position cargo cover (5) on front bow (11), center bow (12), and rear bow (13).



NOTE

Use snap extensions as required.

- (49) Fasten snaps (31) on front, rear, sides, and center of cargo cover (5).
- (50) Unfold front flap (32), right side front flap (33), right side rear flap (34), left side front flap (35), and left side rear flap (36).

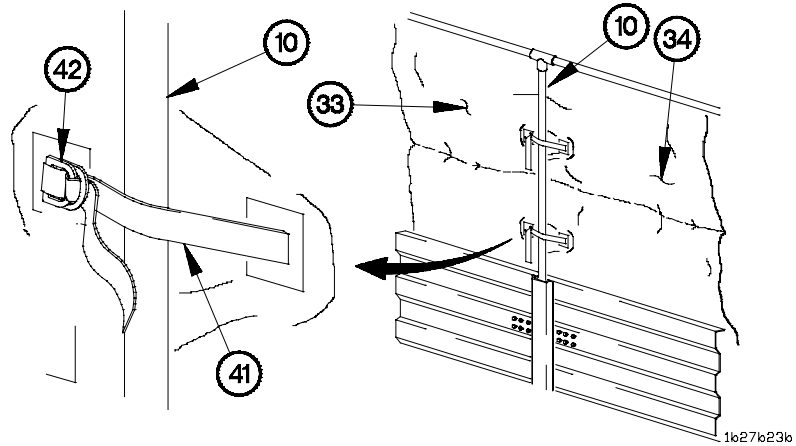


NOTE

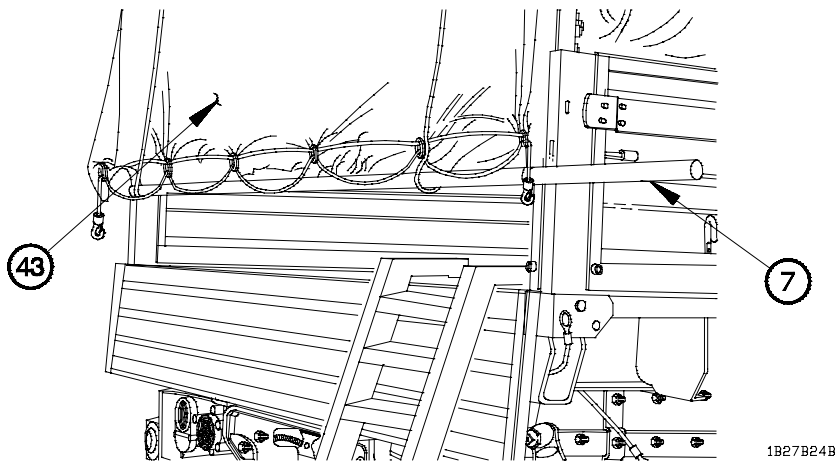
Cargo covers are equipped with either D-rings or buckles and D-rings. Cargo cover with D-rings shown.

- (51) Install cargo cover tiedown (30) in center D-ring (37) on front flap (32) with hook end of strap in outside lip of cargo bed (6).
- (52) Install cargo cover tiedown (30) in right side D-ring (38) on front flap (32) with hook end of strap in outside lip of cargo bed (6).
- (53) Install two straps (39) on right side front flap (33) in two D-rings (40) on front flap (32).
- (54) Perform steps (52) and (53) on left side front flap.

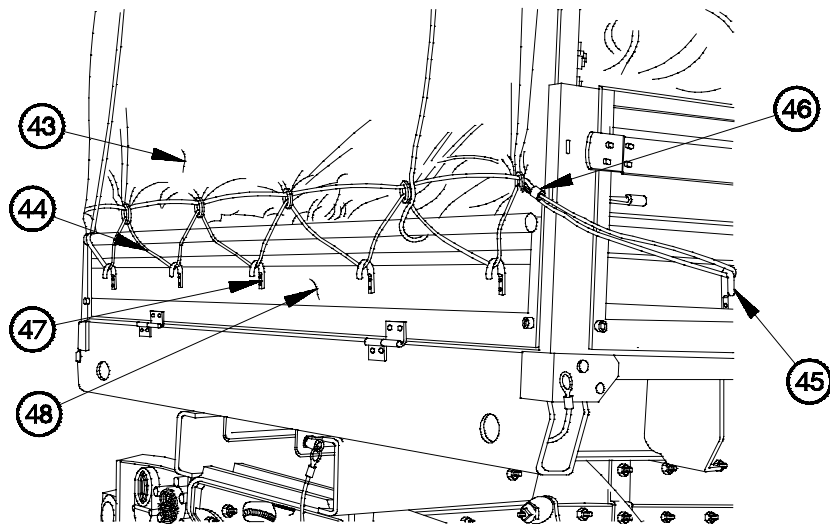
2-27. CARGO COVER KIT INSTALLATION/REMOVAL (CONT)



- (55) Install two straps (41) from right side rear flap (34) on inside of center bow (10) in two D-rings (42) on right side front flap (33).
- (56) Perform step (55) on left side of vehicle.



- (57) Unfold rear flap (43).
- (58) Position steel pole (7) in lower portion of rear flap (43).
- (59) Stow ladder (para 2-26b).



1B27B25B

NOTE

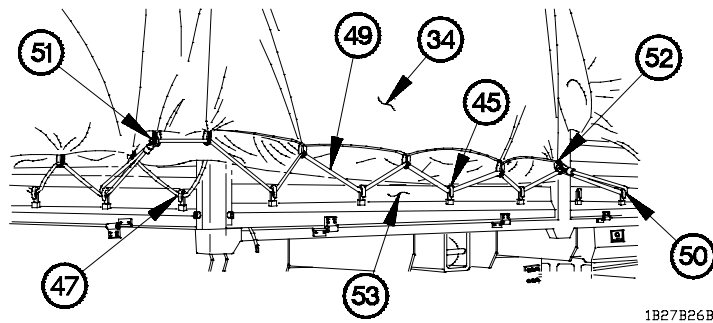
- Cargo cover flaps are equipped with either D-rings or loops and D-rings. Cargo cover flaps with D-rings shown.
- D-rings are attached to lower part of flaps with shock cord placed through D-rings. Shock cord is attached to J-hooks on cargo bed to hold flap down.

(60) Position shock cord (44) on right side of rear flap (43) on J-hook (45) and D-ring (46).

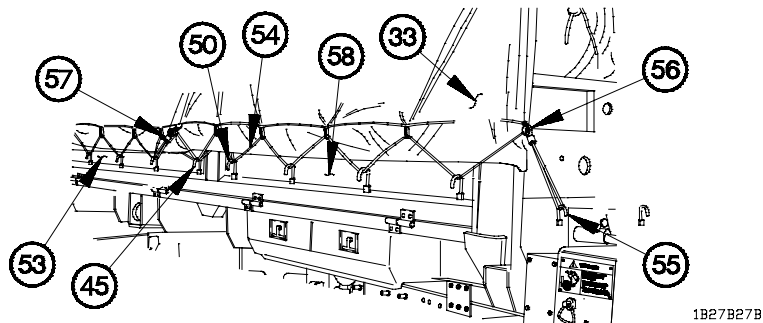
(61) Perform step (60) on left side of vehicle.

(62) Install shock cord (44) on five J-hooks (47) on tailgate (48).

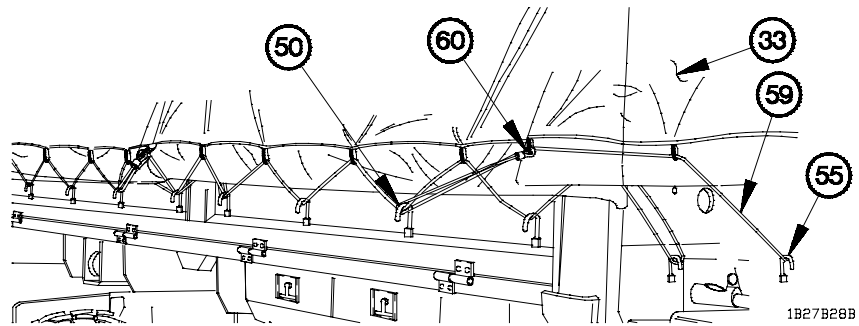
**2-27. CARGO COVER KIT INSTALLATION/REMOVAL
(CONT)**



- (63) Position shock cord (49) on right side rear flap (34) on J-hooks (47 and 50) and D-rings (51 and 52).
- (64) Install shock cord (49) on four J-hooks (45) on right rear side panel (53).
- (65) Perform steps (63) and (64) on left side of vehicle.



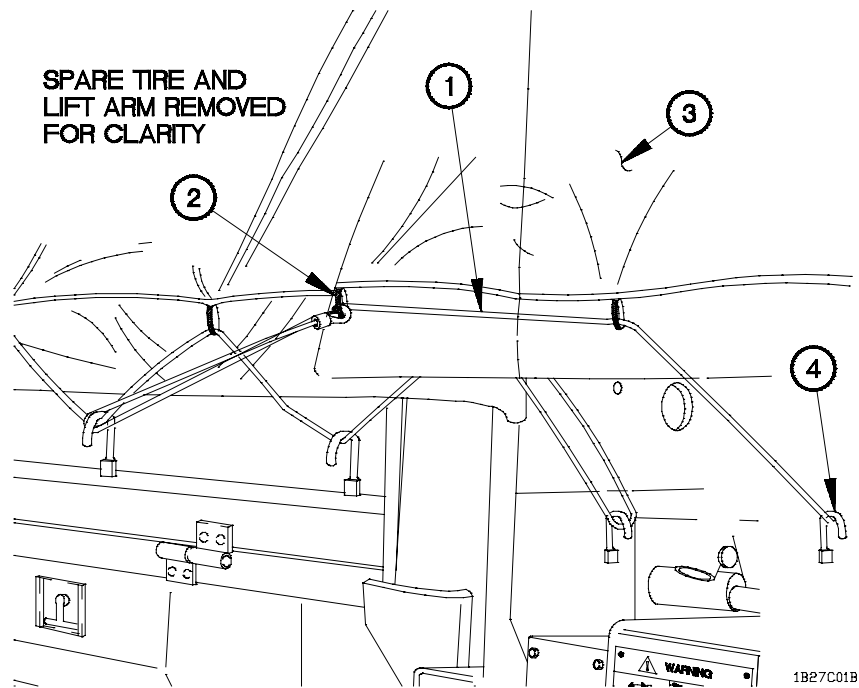
- (66) Position shock cord (54) on right side front flap (33) on J-hook (55) and D-ring (56).
- (67) Position shock cord (54) on right side front flap (33) on J-hook (45) and D-ring (57).
- (68) Install shock cord (54) on four J-hooks (50) on right front side panel (58) and J-hook (45) on right rear side panel (53).
- (69) Perform steps (66) through (68) on left side of vehicle.



- (70) Install shock cord (59) on right side of front flap (33) on J-hook (55).
- (71) Install shock cord (59) on right side of front flap (33) on J-hook (50) and D-ring (60).
- (72) Perform steps (70) and (71) on left side of vehicle.
- (73) Raise spare tire (para 3-5).

2-27. CARGO COVER KIT INSTALLATION/REMOVAL (CONT)

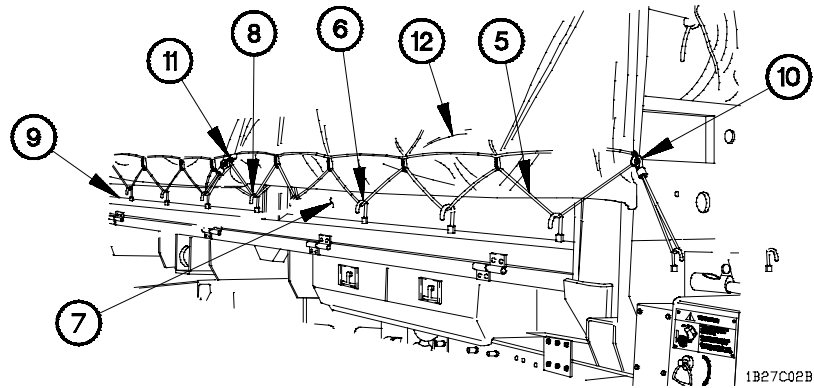
c. Soft Top (Steel Bows) Removal.



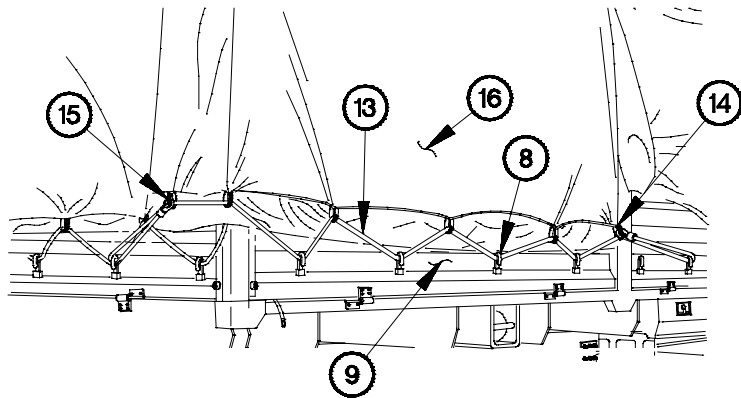
- (1) Lower spare tire (para 3-5).

NOTE

- Cargo cover flaps are equipped with either D-rings or loops and D-rings. Cargo cover flaps with D-rings shown.
 - Steps (2) through (28) require the aid of an assistant.
- (2) Remove shock cord (1) from D-ring (2) on right side of front flap (3).
- (3) Remove shock cord (1) from J-hook (4).
- (4) Perform steps (2) and (3) on left side of front flap.

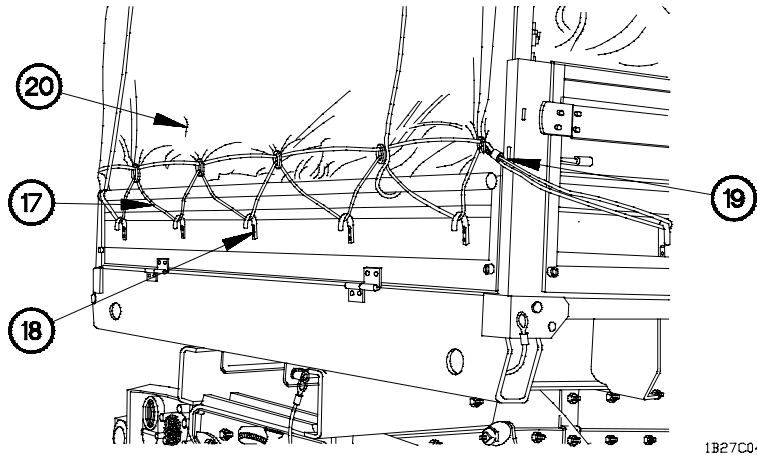


- (5) Remove shock cord (5) from four J-hooks (6) on right front side panel (7) and J-hook (8) on right rear side panel (9).
- (6) Remove shock cord (5) from D-rings (10 and 11) on right side front flap (12).
- (7) Perform steps (5) and (5) on left side front flap.



- (8) Remove shock cord (13) from four J-hooks (8) on right rear side panel (9).
- (9) Remove shock cord (13) from D-rings (14 and 15) on right side rear flap (16).
- (10) Perform steps (8) and (9) on left side rear flap.

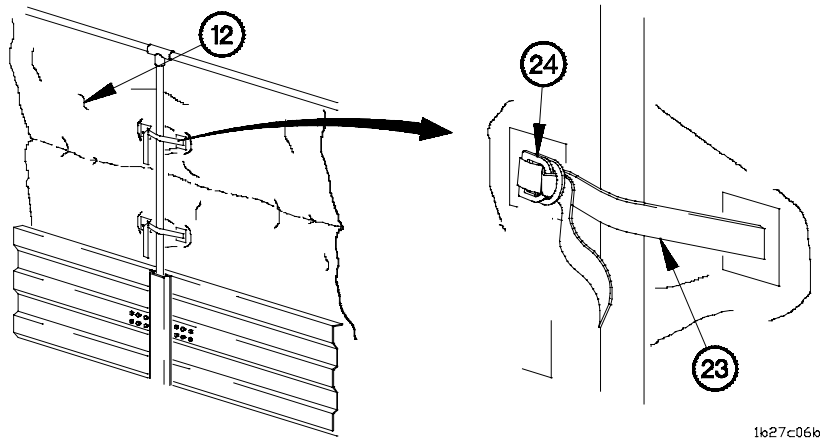
**2-27. CARGO COVER KIT INSTALLATION/REMOVAL
(CONT)**



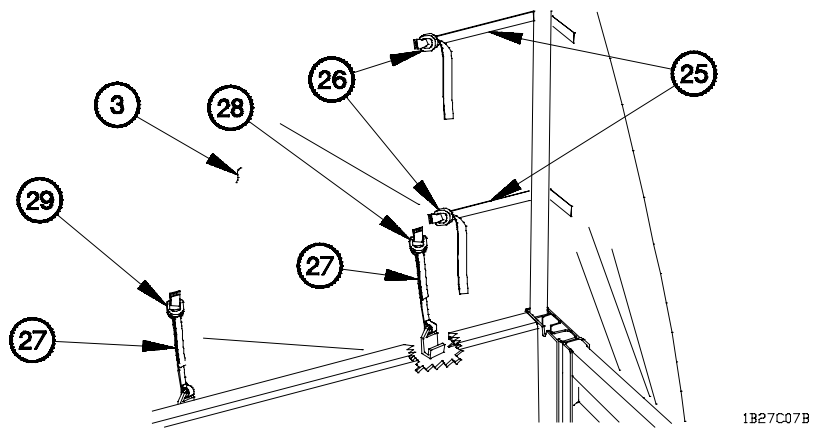
- (11) Remove shock cord (17) from five J-hooks (18).
- (12) Remove shock cord (17) from D-ring (19) on rear flap (20).
- (13) Perform step (12) on left side of vehicle.



- (14) Lower ladder (para 2-26a).
- (15) Remove steel pole (21) from rear flap (20).
- (16) Fold rear flap (20) on top of cargo cover (22).

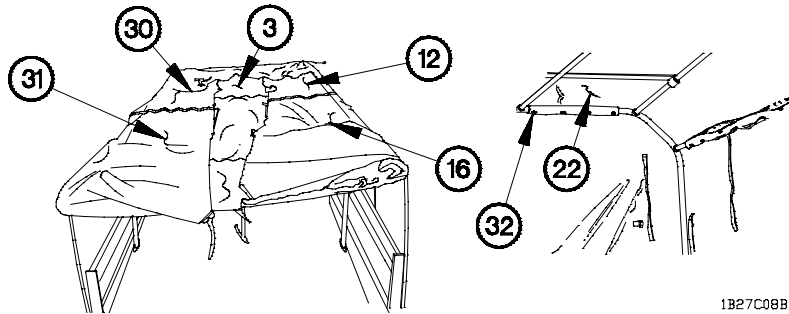


- (17) Remove two straps (23) from D-rings (24) on center right side front side flap (12).
- (18) Perform step (17) on left side of vehicle.



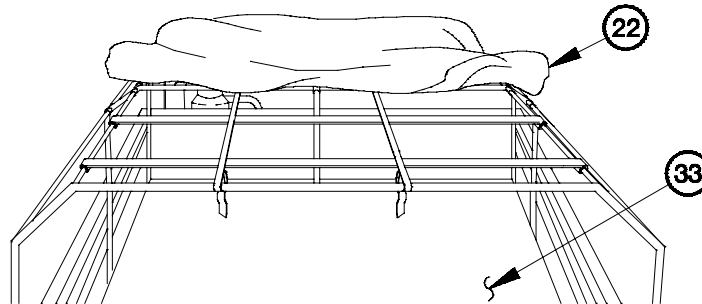
- (19) Remove two straps (25) from D-rings (26) on right side of front flap (3).
- (20) Remove cargo cover tiedown (27) from right side D-ring (28) on front flap (3).
- (21) Perform steps (19) and (20) on left side of front flap.
- (22) Remove cargo cover tiedown (27) from center D-ring (29) on front flap (3).

**2-27. CARGO COVER KIT INSTALLATION/REMOVAL
(CONT)**



1B27C08B

- (23) Fold front flap (3), right side front flap (12), right side rear flap (16), left side front flap (30), and left side rear flap (31) on top of cargo cover (22).
- (24) Unfasten snaps (32) on front, rear, sides, and center of cargo cover (22).
- (25) Fold cargo cover (22) on front of vehicle.



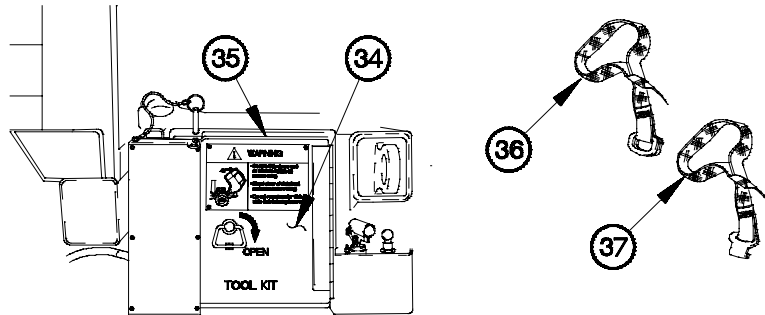
1B27C09B

- (26) Fold right side of cargo cover (22) toward center of cargo bed (33).
- (27) Fold left side of cargo cover (22) toward center of cargo bed (33).

WARNING

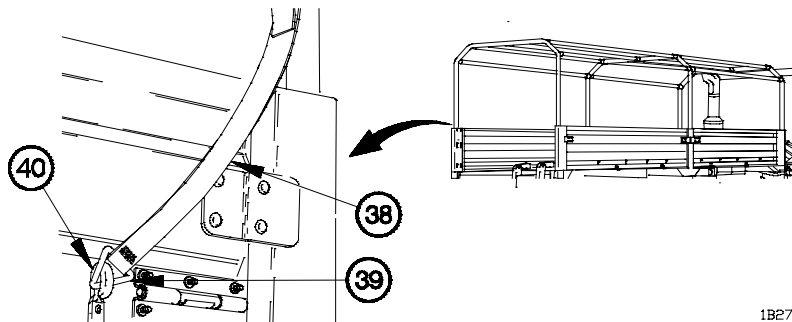
Cargo cover weighs approximately 60 lbs (27 kgs). An assistant is required to lift cargo cover. Failure to comply may result in injury to personnel or damage to equipment.

- (28) Remove cargo cover (22) from vehicle.



1B27C10B

- (29) Open door (34) on tool box (35).
- (30) Remove stowage strap (36) from tool box (35).
- (31) Stow three cargo cover tiedowns (37) in tool box (35).
- (32) Close door (34) on tool box (35).



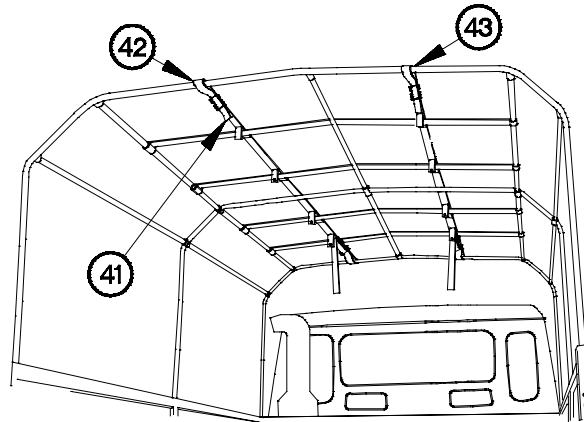
1B27C11B

NOTE

Left and right sides of front, center, and rear bows are unsecured the same way. Rear bow left side shown.

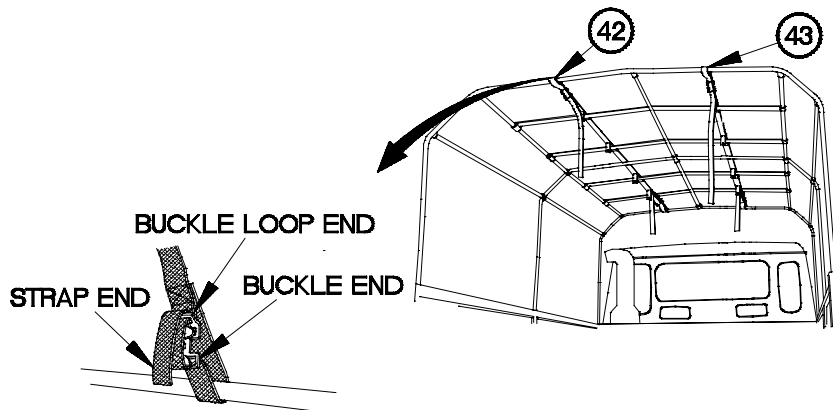
- (33) Loosen tiedown strap (38).
- (34) Remove tri-ring (39) on tiedown strap (38) from J-hook (40).
- (35) Perform steps (33) and (34) on remaining tiedown straps.

**2-27. CARGO COVER KIT INSTALLATION/REMOVAL
(CONT)**



1B27C14B

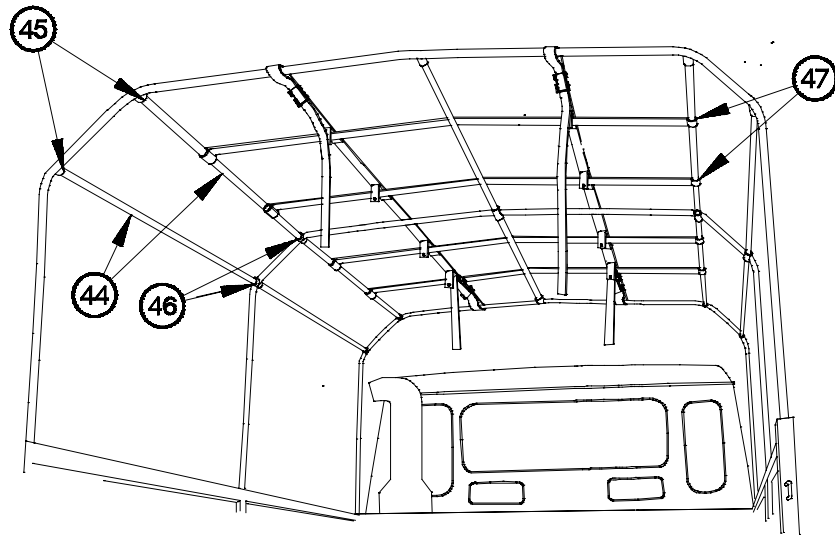
(36) Open four flaps (41) on left strap support (42) and right strap support (43).



1B27C15B

(37) Remove two rear strap ends from buckle loop ends on left strap support (42) and right strap support (43).

(38) Loosen left rear strap support (42).



1B27C12B

NOTE

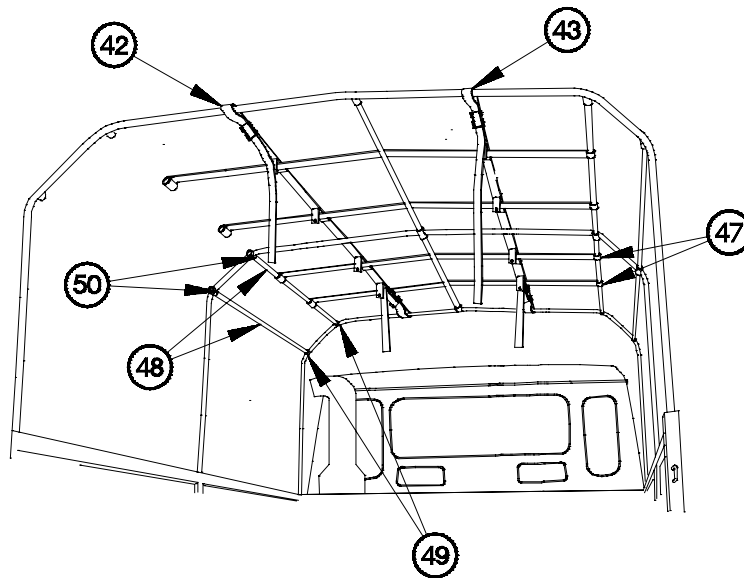
- Left and right tubes are removed the same way. Left side tubes shown.
- Steps (39) through (46) require the aid of an assistant.

(39) Remove rear tube (44) from rear bow bracket (45) and center bow bracket (46).

(40) Remove rear tube (44) from center bow bracket (46) and rear bow bracket (45).

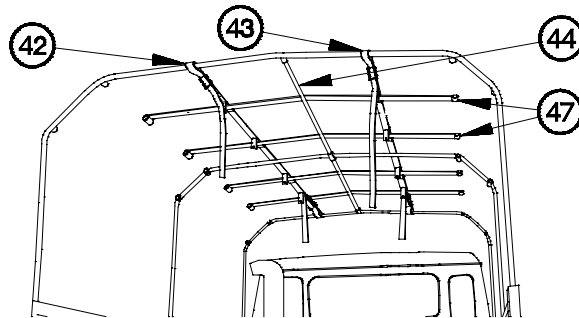
(41) Remove rear tube (44) from two braces (47).

**2-27. CARGO COVER KIT INSTALLATION/REMOVAL
(CONT)**



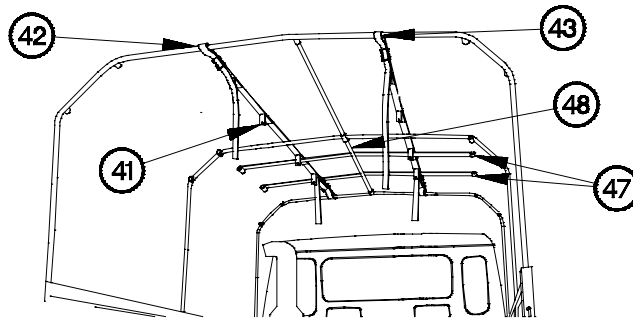
1B27C13B

- (42) Remove front tube (48) from front bow bracket (49) and center bow bracket (50).
- (43) Remove front tube (48) from front bow bracket (49) and center bow bracket (50).
- (44) Remove front tube (48) from two braces (47).
- (45) tighten left rear strap support (42).
- (46) Loosen right rear strap support (43).
- (47) Perform steps (39) through (44) on right side tubes.
- (48) Tighten right rear strap support (43).



1B27C16B

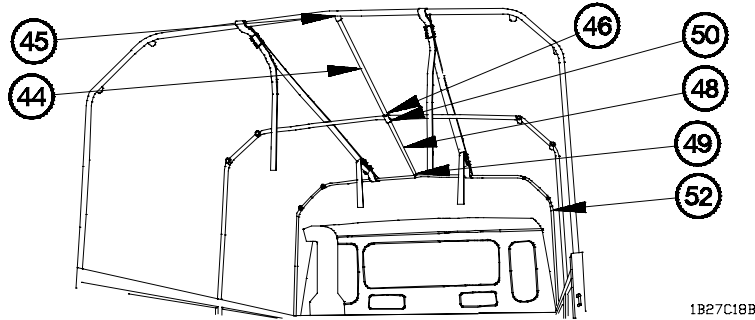
- (49) Remove two braces (47) from rear tube (44), left strap support (42), and right strap support (43).



1B27C17B

- (50) Remove two braces (47) from front tube (48), left strap support (42), and right strap support (43).
- (51) Close four flaps (41) on left strap support (42) and right strap support (43).

**2-27. CARGO COVER KIT INSTALLATION/REMOVAL
(CONT)**



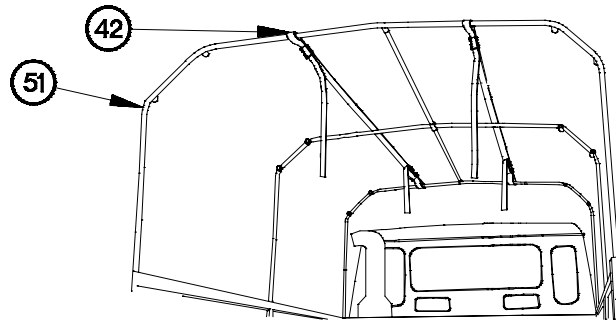
1B27C19B

NOTE

Steps (52) and (53) require the aid of an assistant.

(52) Remove rear tube (44) from center bow bracket (46) and rear bow bracket (45).

(53) Remove front tube (48) from front bow bracket (49) and center bow bracket (50).

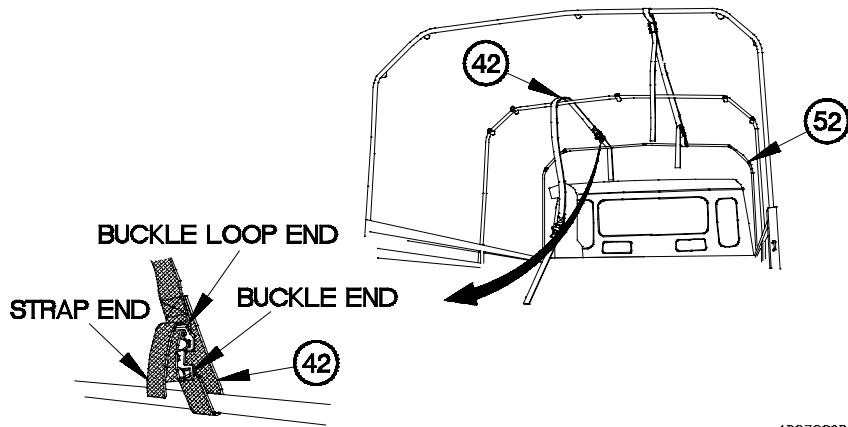


1B27C19B

NOTE

Left and right strap supports are removed the same way. Left strap support shown.

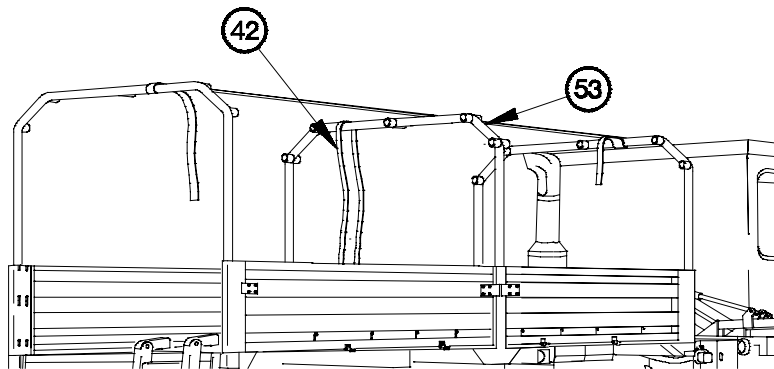
(54) Remove left strap support (42) from rear bow (51).



1B27C20B

(55) Remove front strap end from buckle loop end on left strap support (42).

(56) Remove left strap support from front bow (52).

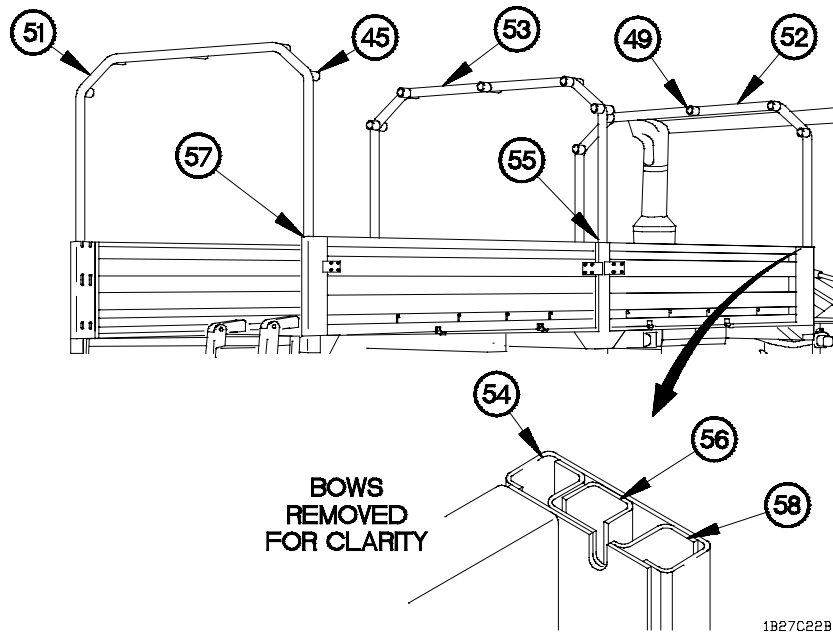


1B27C21B

(57) Remove left strap support (42) from center bow (53).

(58) Perform steps (54) through (57) on right strap support.

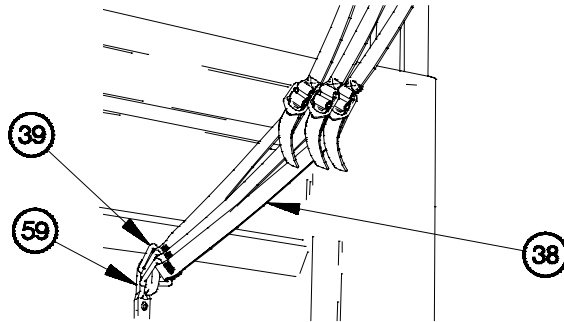
**2-27. CARGO COVER KIT INSTALLATION/REMOVAL
(CONT)**



NOTE

Steps (59) through (64) require the aid of an assistant.

- (59) Remove front bow (52) from front cargo bed pockets (54).
- (60) Position front bow (52) in front cargo bed pockets (54) with front bow brackets (49) towards front of vehicle.
- (61) Remove center bow (53) from rear pockets of center cargo bed stakes (55).
- (62) Position center bow (53) in center cargo bed pockets (56).
- (63) Remove rear bow (51) from rear pockets of rear cargo bed stakes (57).
- (64) Position rear bow (51) in rear cargo bed pockets (58) with rear bow brackets (45) towards rear of vehicle.

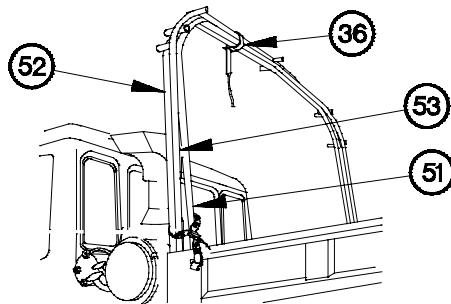


1B27C23B

NOTE

Left and right sides of front, center, and rear bows are secured the same way. Right side shown.

- (65) Position three tiedown straps (38) on J-hook (59) with three tri-rings (39).
- (66) Tighten three tiedown straps (38).
- (67) Perform steps (65) and (66) on left side.



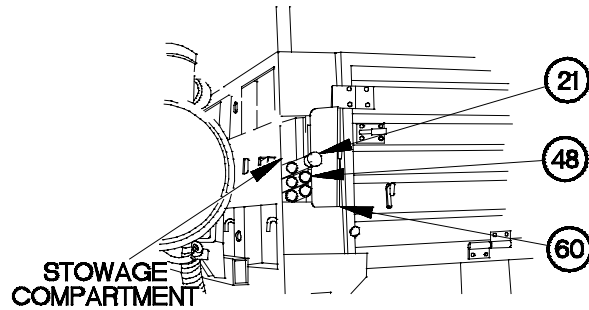
1B27C24B

NOTE

Stowage strap should be positioned between center bow brackets and left inside bow brackets.

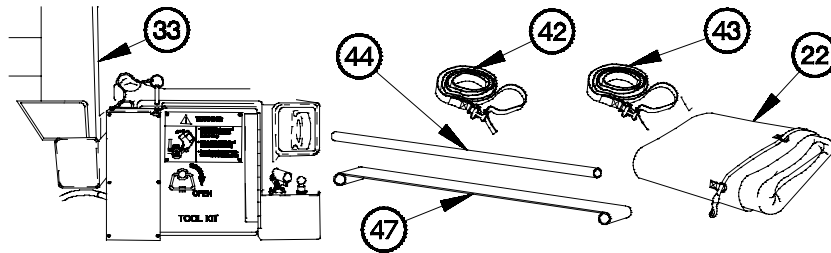
- (68) Install stowage strap (36) on front bow (52), center bow (53) and rear bow (51).

**2-27. CARGO COVER KIT INSTALLATION/REMOVAL
(CONT)**



1B27C25B

- (69) Open stowage compartment door (60).
- (70) Stow five front tubes (48) and steel pole (21) in stowage compartment.
- (71) Close stowage compartment door (60).



1B27C26B

WARNING

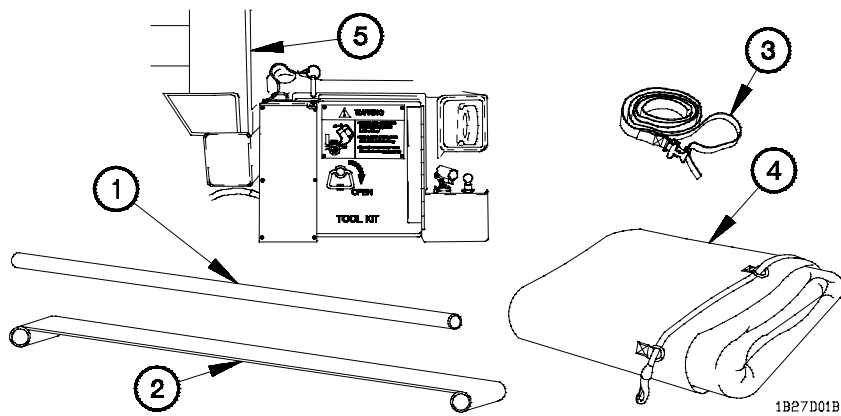
Cargo cover weighs approximately 60 lbs (27 kgs). An assistant is required to lift cargo cover. Failure to comply may result in injury to personnel or damage to equipment.

NOTE

Step (72) requires the aid of an assistant.

- (72) Stow five rear tubes (44), four braces (47), left strap support (42), right strap support (43), and cargo cover (22) on cargo bed (33).
- (73) Raise spare tire (para 3-5).
- (74) Stow ladder (para 2-26b).

d. Soft Top Kit (Steel Bows Removal).



WARNING

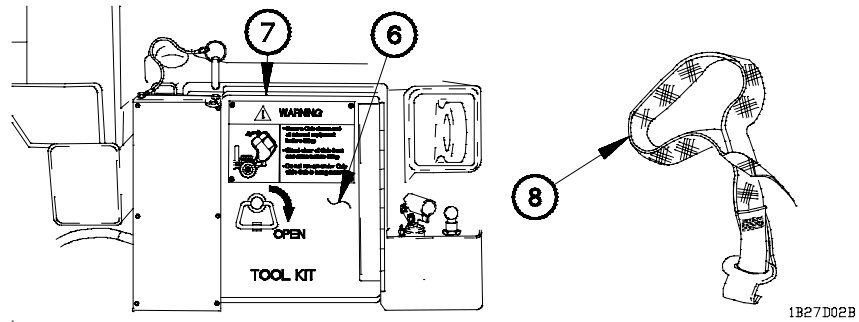
Cargo cover weighs approximately 60 lbs (27 kgs). An assistant is required to lift cargo cover. Failure to comply may result in injury to personnel or damage to equipment.

NOTE

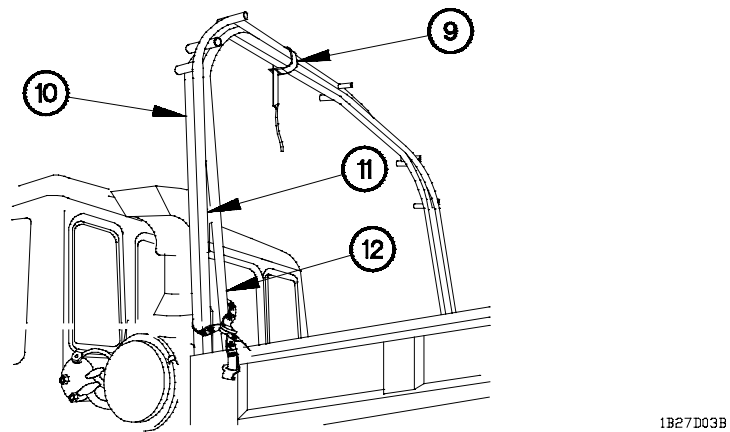
Step (1) requires the aid of an assistant.

- (1) Lower ladder (para 2-26b).
- (2) Remove five rear tubes (1), four braces (2), two strap supports (3), and cargo cover (4) from cargo bed (5).

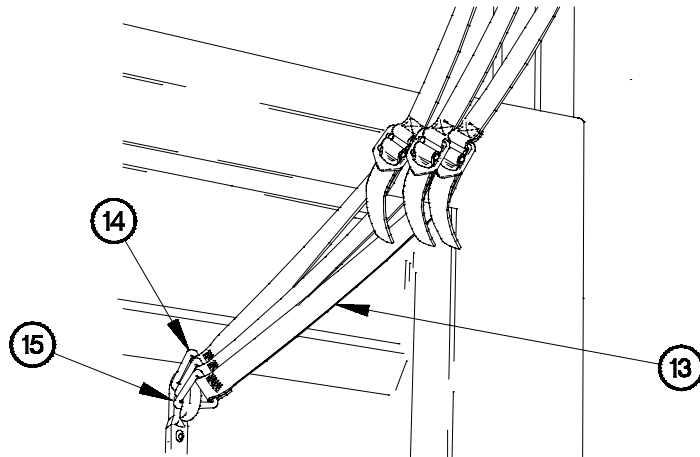
**2-27. CARGO COVER KIT INSTALLATION/REMOVAL
(CONT)**



- (3) Open door (6) on tool box (7).
- (4) Remove three cargo cover tiedowns (8) from tool box (7).
- (5) Close door (6) on tool box (7).



- (6) Remove stowage strap (9) from front bow (10), center bow (11), and rear bow (12).

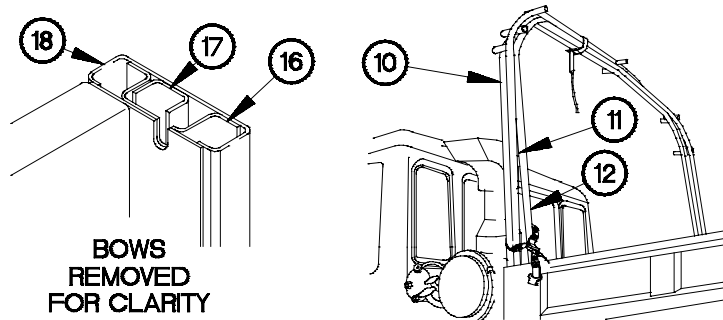


1B27D04B

NOTE

Left and right sides of front, center, and rear bows are unsecured the same way. Right side shown.

- (7) Loosen three tiedown straps (13).
- (8) Remove three tri-rings (14) on tiedown straps (13) from J-hook (15).
- (9) Perform steps (7) and (8) on left side.



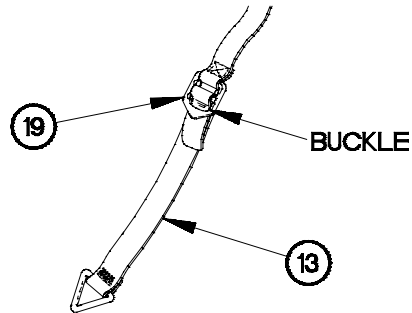
1B27D05B

NOTE

Steps (10) through (12) require the aid of an assistant.

- (10) Remove rear bow (12) from rear cargo bed pockets (16).
- (11) Remove center bow (11) from center cargo bed pockets (17).
- (12) Remove front bow (10) from front cargo bed pockets (18).

**2-27. CARGO COVER KIT INSTALLATION/REMOVAL
(CONT)**

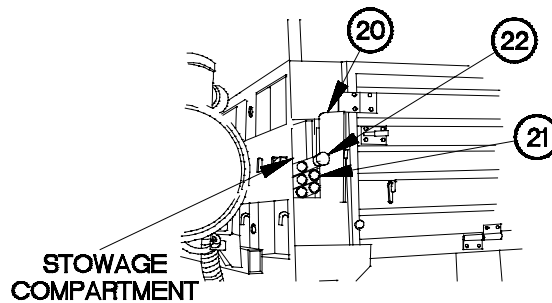


1B27D06B

NOTE

Front, center, and rear bows have two bow straps and tiedown straps. All tiedown straps are removed from bow straps the same way. One shown.

- (13) Remove tiedown strap (13) from buckle on bow strap (19).
- (14) Perform step (13) on remaining tiedown straps.

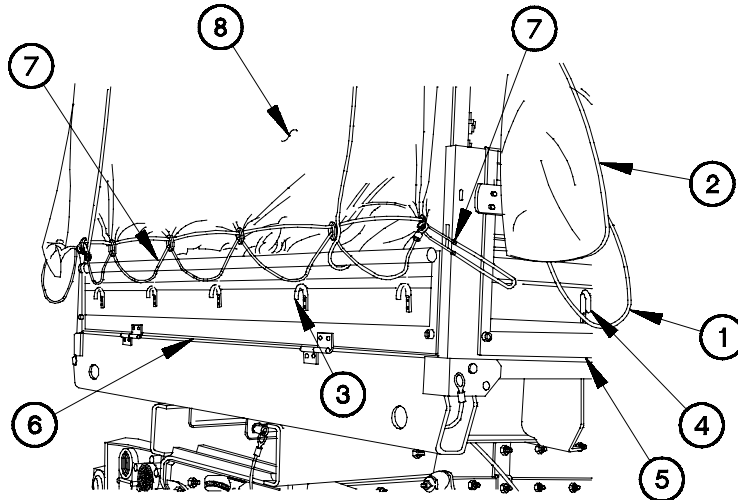


1B27D07B

- (15) Open stowage compartment door (20).
- (16) Remove five front tubes (21) and steel pole (22) from stowage compartment.
- (17) Close stowage compartment door (20).
- (18) Raise ladder (para 2-26b).

2-28. CARGO COVER FLAP OPERATION

a. Raising Rear Flap.

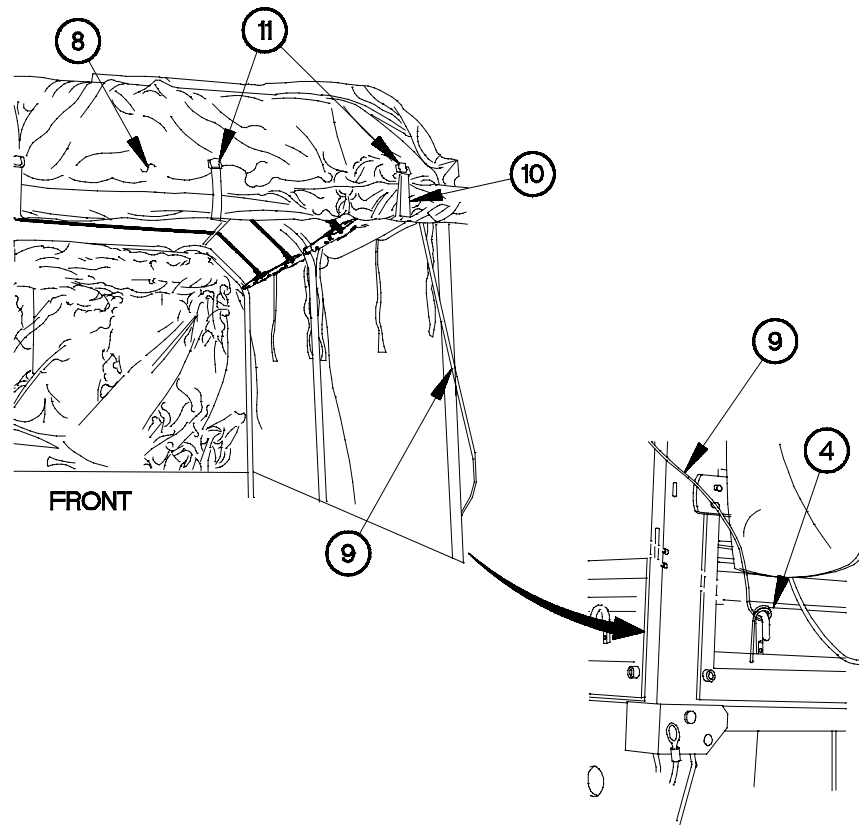


1B28A011

NOTE

Left and right side rear flaps are disconnected the same way. Right side rear flap shown.

- (1) Remove shock cord (1) on right side rear flap (2) from J-hooks (3 and 4) on right side rear panel (5) and tailgate (6).
- (2) Remove shock cord (7) on right side of rear flap (8) from J-hook (4) on right side rear panel (5).
- (3) Perform steps (1 and 2) on left side of rear flap.
- (4) Remove shock cord (7) from five J-hooks (3) on tailgate (6).
- (5) Lower ladder (para 2-26a).



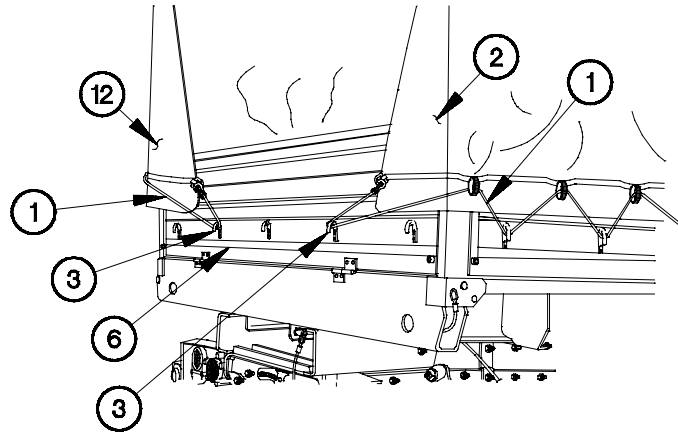
1B28A021

NOTE

Steps (6) through (9) are performed from inside cargo bed.

- (6) Pull draw string (9) to raise rear flap (8).
- (7) Tie draw string (9) to J-hook (4).
- (8) Install five straps (10) around rear flap (8) to five D-rings (11).
- (9) Stow ladder (para 2-26b).

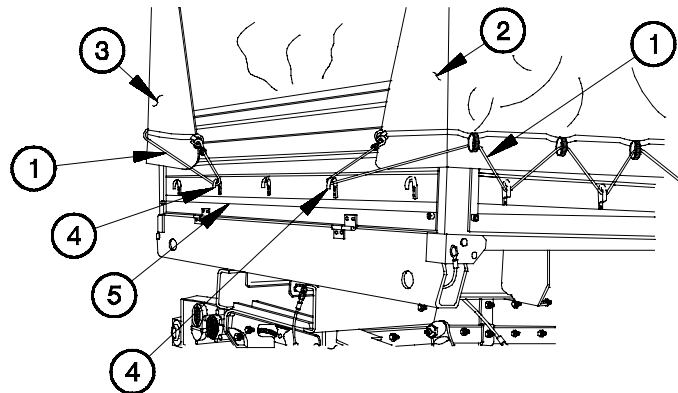
2-28. CARGO COVER FLAP OPERATION (CONT)



1B28A031

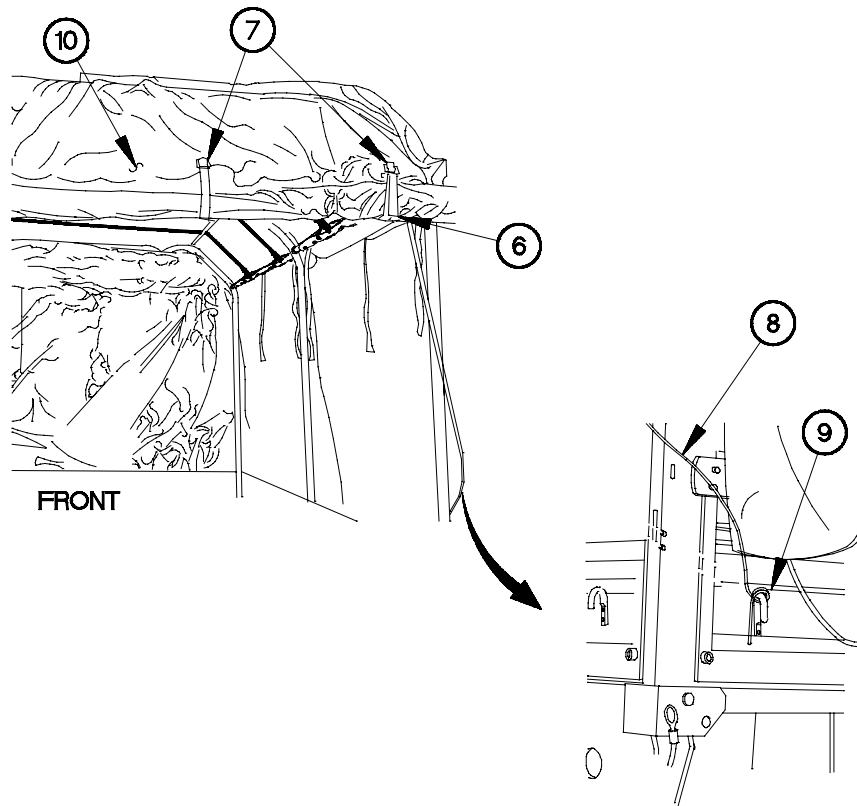
- (10) Pull right side rear flap (2) over tailgate (6).
- (11) Position shock cord (1) on J-hook (3).
- (12) Pull left side rear flap (12) over tailgate (6).
- (13) Position shock cord (1) on J-hook (3).

b. Lowering Rear Flap.



1B28B011

- (1) Remove two shock cords (1) on right and left side rear flaps (2 and 3) from two J-hooks (4) on tailgate (5).
- (2) Lower ladder (para 2-26a).



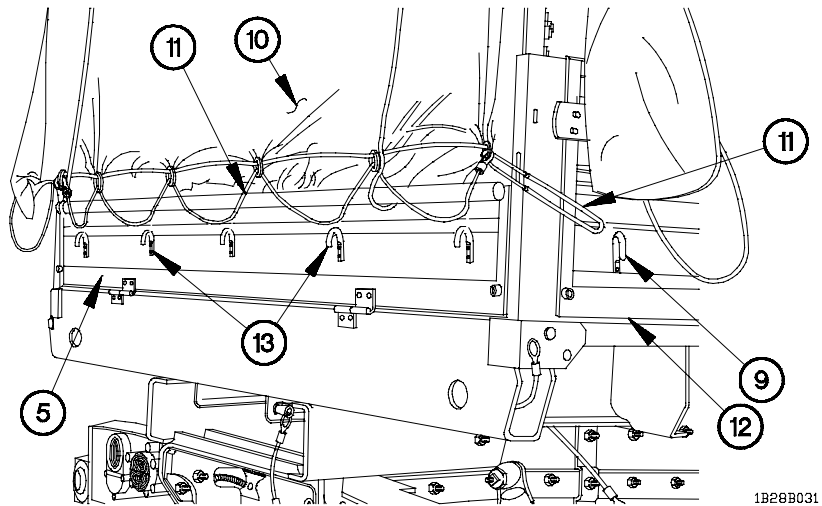
1B29B021

NOTE

Steps (3) through (5) are performed inside cargo bed.

- (3) Disconnect five straps (6) from D-rings (7).
- (4) Remove draw string (8) from J-hook (9).
- (5) Lower rear flap (10) with draw string (8).
- (6) Stow ladder (para 2-26b).

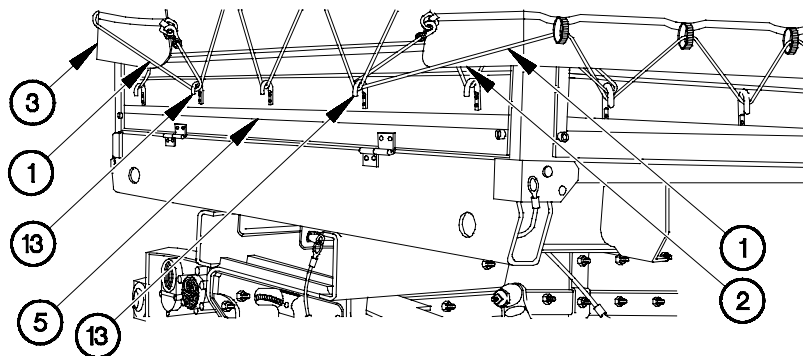
2-28. CARGO COVER FLAP OPERATION (CONT)



NOTE

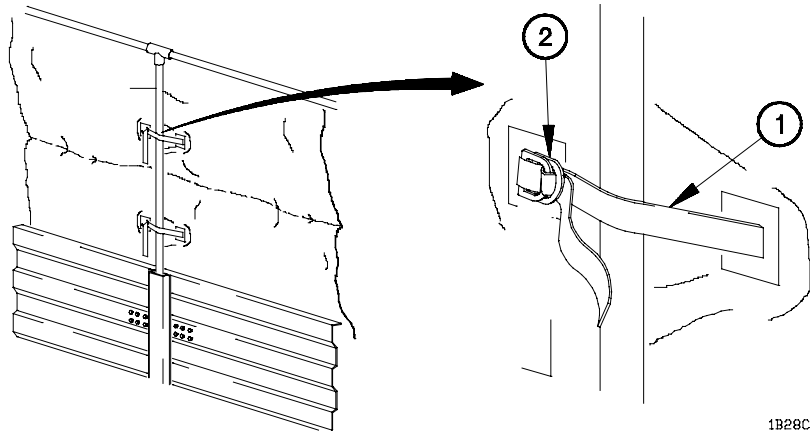
Right and left side rear flaps are installed the same way. Right side shown.

- (7) Install shock cord (11) on rear flap (10) to J-hook (9) on right and left side rear panels (12).
- (8) Install shock cord (11) on five J-hooks (13) on tailgate (5).



- (9) Install shock cord (1) from right and left side rear flaps (2 and 3) on two J-hooks (13) on tailgate (5).

c. Raising Side Flaps.



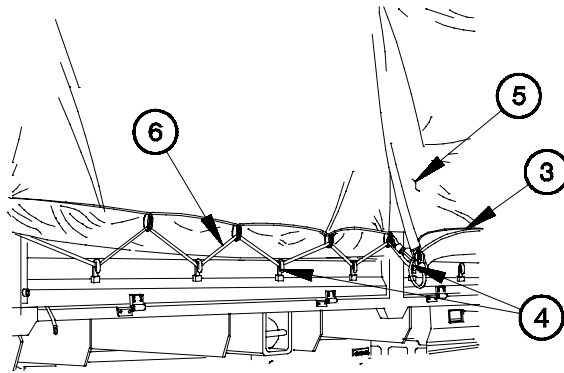
1B28C011

- (1) Raise rear flap (para 2-28a).

NOTE

All side flaps are raised the same way. Right side rear flap shown.

- (2) Disconnect two straps (1) from D-rings (2).



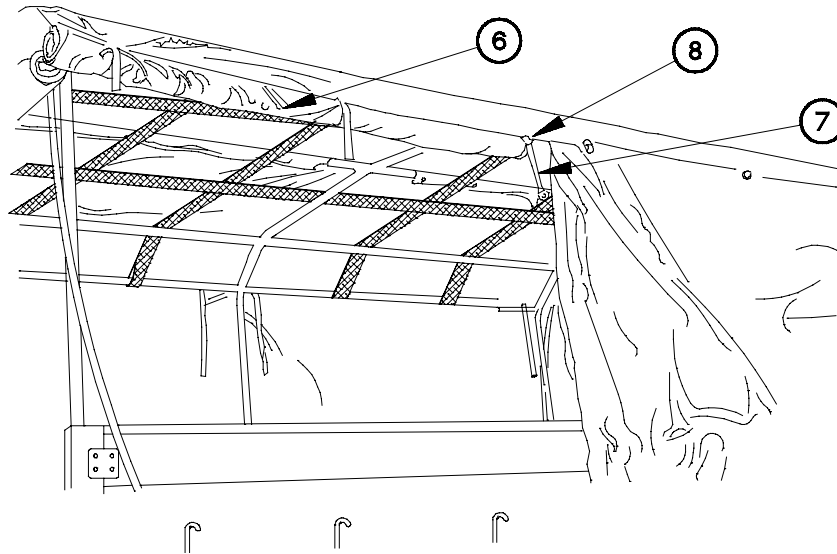
1B28C021

NOTE

Steps (3) through (7) require the aid of two assistants.

- (3) Remove shock cord (3) from two J-hooks (4) on right side front flap (5).
- (4) Remove shock cord (6) from five J-hooks (4).

2-28. CARGO COVER FLAP OPERATION (CONT)



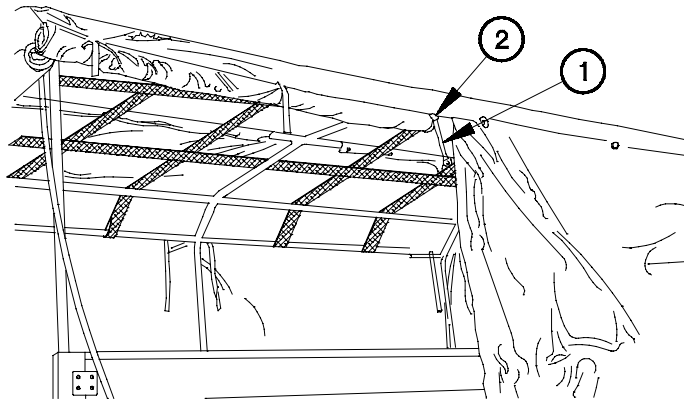
1B28C031

NOTE

Steps (5) through (7) are performed from inside cargo bed.

- (5) Roll up right side rear flap (6).
- (6) Wrap three straps (7) around right side rear flap (6).
- (7) Install three straps (7) through D-rings (8).

d. Lowering Side Flaps.

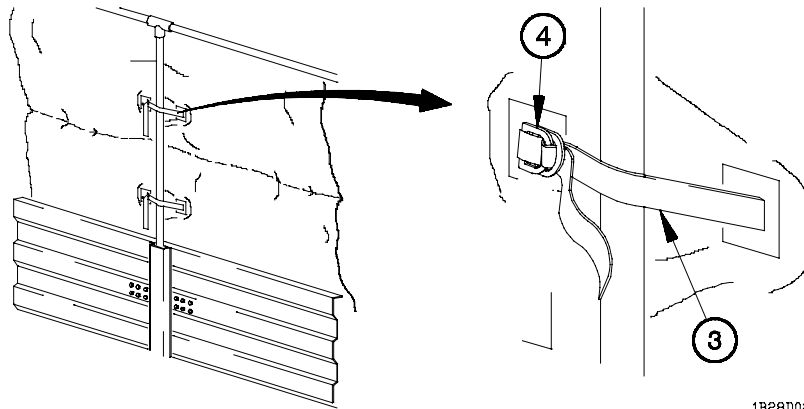


1B28D011

NOTE

- All side flaps are lowered the same way. Right side rear flap shown.
- Step (1) is performed from inside of cargo bed.

(1) Remove three straps (1) from D-rings (2).

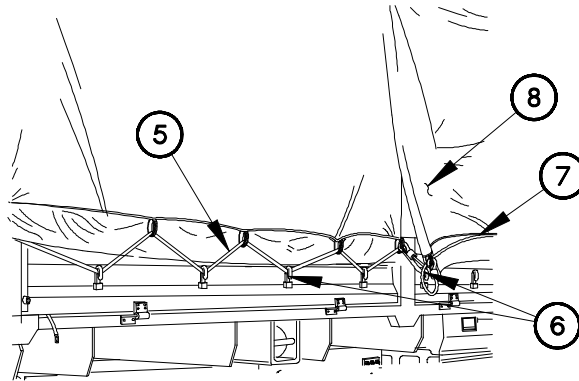


1B28D021

(2) Connect two straps (3) to D-rings (4).

(3) Stow ladder (para 2-26b).

2-28. CARGO COVER FLAP OPERATION (CONT)



1b28a031

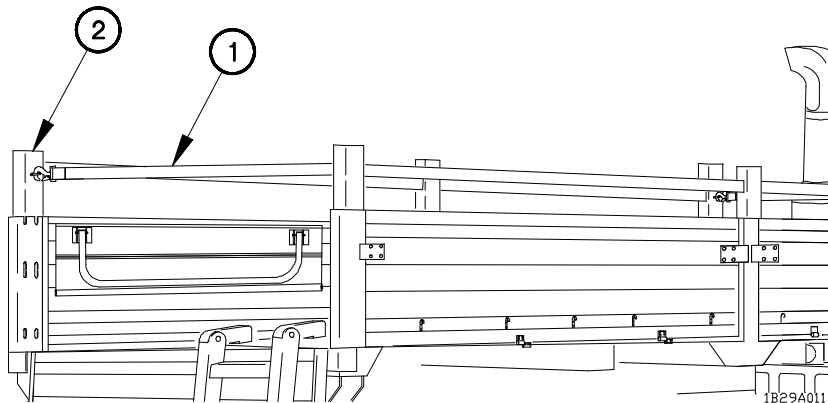
- (4) Install shock cord (5) on five J-hooks (6).
- (5) Install shock cord (7) on two J-hooks (6) on right side front flap (8).
- (6) Lower rear flap (para 2-28b).

2-29. TROOPSEAT KIT LOWERING/RAISING

NOTE

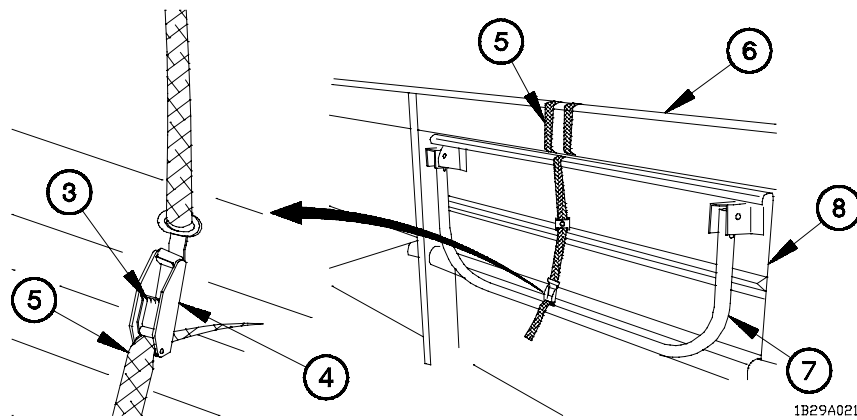
Troopseats have two ways to secure seats in raised position. One of the ways is with a strap, the other is with a holding bracket and rubber cord assembly.

a. Lowering Troopseats with Strap.

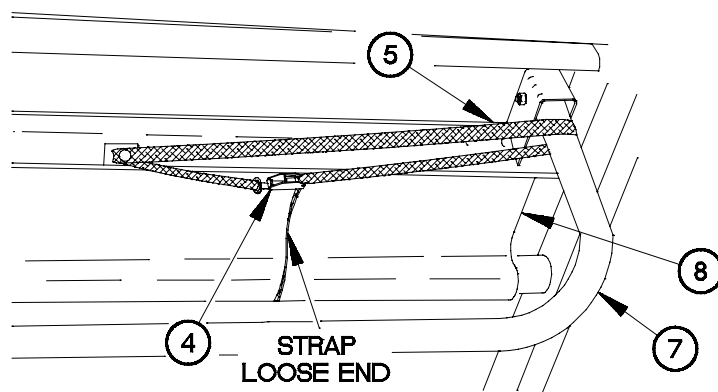


1B29A011

- (1) Lower ladder (para 2-26a).
- (2) Disconnect end of safety strap (1) from left rear seat post (2).

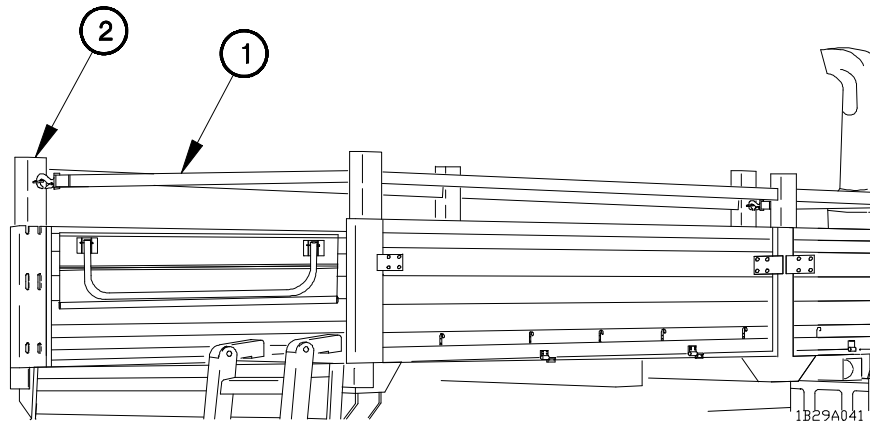


- (3) Push release tab (3) on buckle (4).
- (4) Pull out on buckle (4) to loosen strap (5).
- (5) Unhook strap (5) from buckle (4).
- (6) Unwrap strap (5) from backrest (6).
- (7) Unfold leg (7) from seat panel (8).



- (8) Lower seat panel (8) until leg (7) contacts floor of cargo bed.
- (9) Wrap long end of strap (5) around leg (7).
- (10) Hook strap (5) to buckle (4).
- (11) Tighten strap (5) by pulling on strap loose end.

2-29. TROOPSEAT KIT LOWERING/RAISING (CONT)



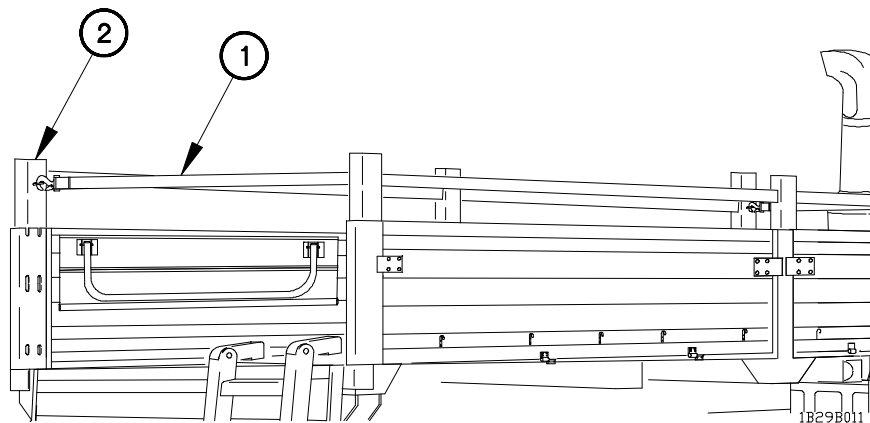
WARNING

Ensure safety strap is fastened across back and front of vehicle before transporting troops. Failure to comply may result in serious injury or death to personnel.

(12) Connect safety strap (1) to left rear seat post (2).

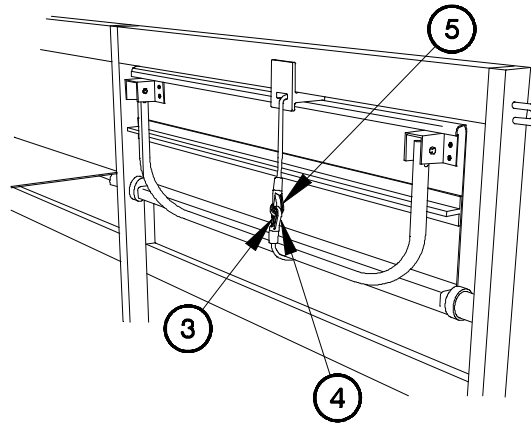
(13) Stow ladder (para 2-26b).

b. Lowering Troopseats with Holding Bracket Assembly.



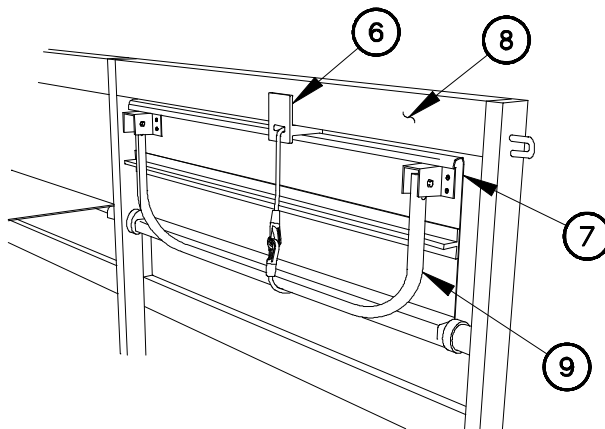
(1) Lower ladder (para 2-26a).

(2) Disconnect end of safety strap (1) from left rear seat post (2).



1B29B051

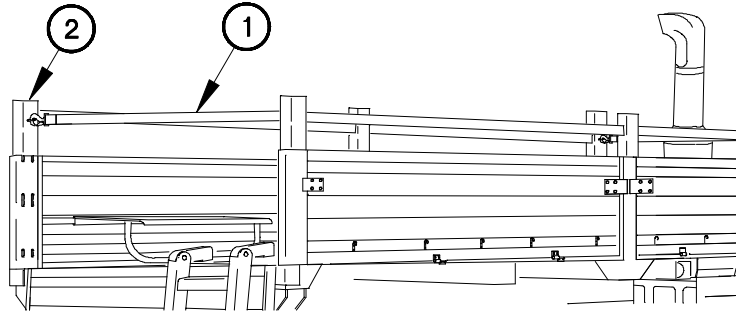
- (3) Press down on tab (3) on hook (4).
- (4) Remove lower hook (4) from upper hook (5).



1B29B061

- (5) Slide holding bracket (6) until holding bracket is slid off of seat panel (7).
- (6) Remove holding bracket (6) from backrest (8).
- (7) Unfold drop leg (9) from seat panel (7).
- (8) Lower seat panel (7) until drop leg (9) contacts floor of cargo bed.

2-29. TROOPSEAT KIT LOWERING/RAISING (CONT)



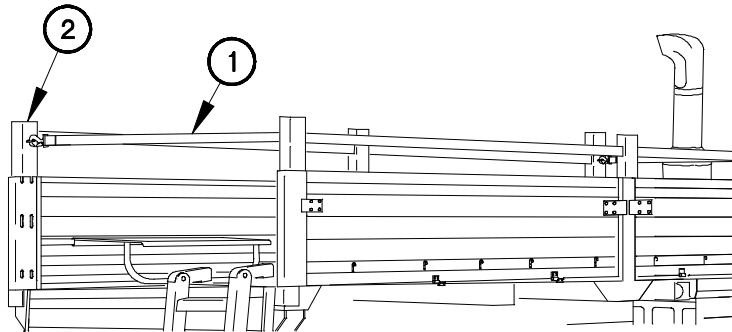
1B29B071

WARNING

Ensure safety strap is fastened across back and front of vehicle before transporting troops. Failure to comply may result in serious injury or death to personnel.

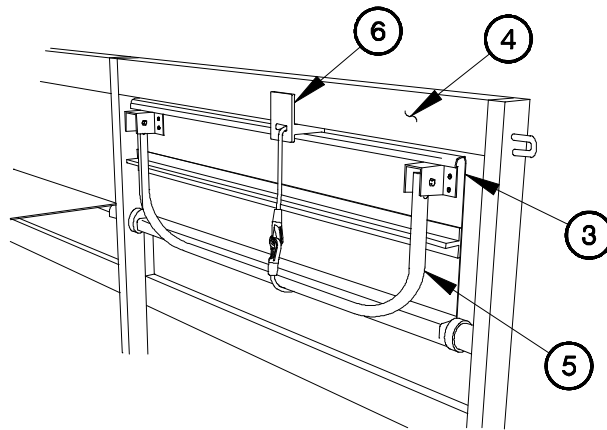
- (9) Connect safety strap (1) to left rear seat post (2).
- (10) Stow ladder (para 2-32b).

c. Raising Troopseats with Holding Bracket.



1B29C011

- (1) Lower ladder (para 2-32a).
- (2) Disconnect safety strap (1) from left rear seat post (2).

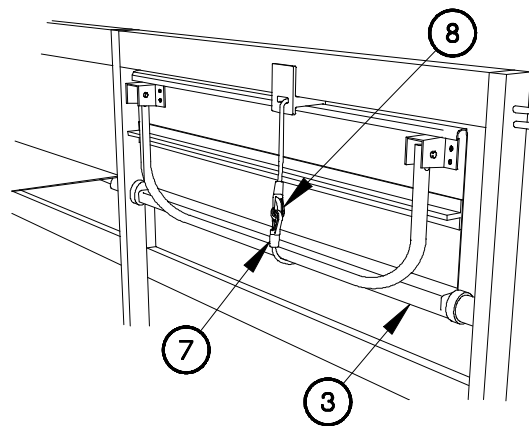


1B29C021

CAUTION

Troopseats must be stowed in the raised position when not in use. Failure to comply may result in damage to equipment.

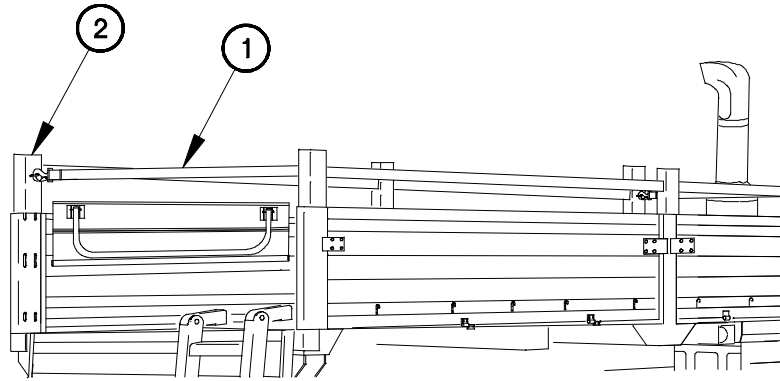
- (3) Raise seat panel (3) up until edge of seat panel is under backrest (4).
- (4) Fold drop leg (5) down to seat panel (3).
- (5) Slide holding bracket (6) on backrest (4) and seat panel (3) until holding bracket (6) is centered on seat panel (3).



1B29C031

- (6) Pull hook and rubber cord (7) around and under bottom of seat panel (3).
- (7) Pull up on hook and rubber cord (7) while pushing down on hook and rubber cord (8) until the two hooks can connect.

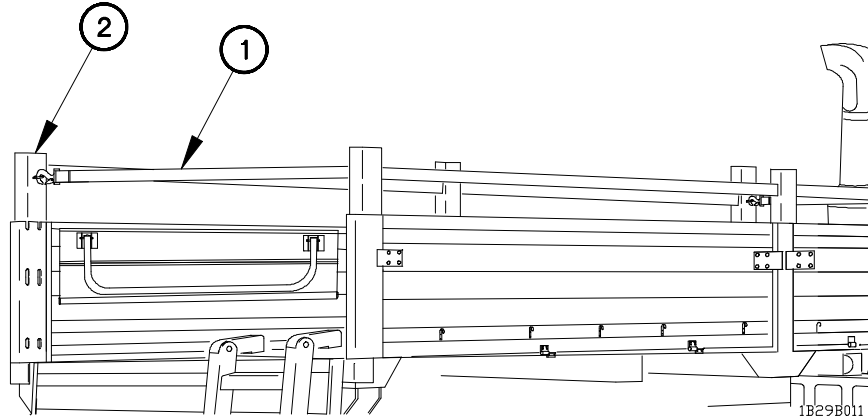
2-29. TROOPSEAT KIT LOWERING/RAISING (CONT)



1B29C041

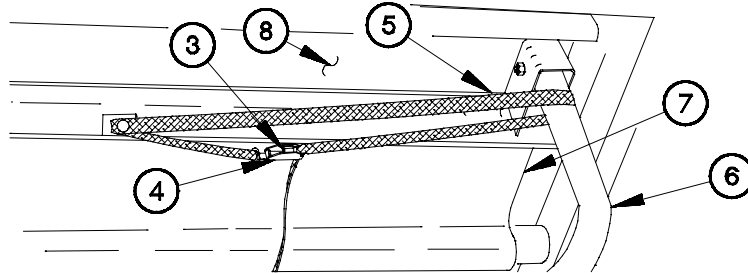
- (8) Connect safety strap (1) to left rear seat post (2).
- (9) Stow ladder (para 2-32a).

d. Raising Troopseats with Strap.



1B29B011

- (1) Lower ladder (para 2-26a).
- (2) Disconnect end of safety strap (1) from left rear seat post (2).

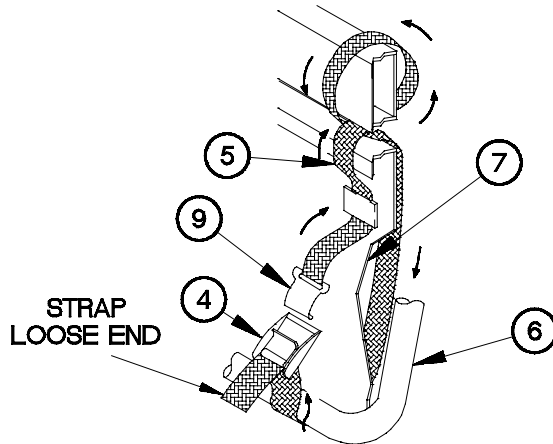


1B29B021

CAUTION

Troopseats must be stowed in the raised position when not in use. Failure to comply may result in damage to equipment.

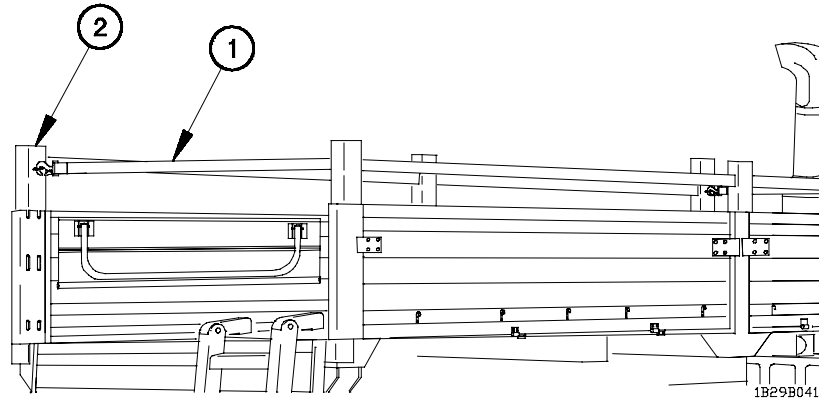
- (3) Push release tab (3) on buckle (4).
- (4) Unhook strap (5) from leg (6).
- (5) Raise seat panel (7) up until edge of seat panel is under backrest (8).



1B29B031

- (6) Fold leg (6) down to seat panel (7).
- (7) Position hook (9) of strap (5) down.
- (8) Wrap strap (5), as shown, to connect to buckle (4).
- (9) Tighten strap (5) by pulling on strap loose end.

2-29. TROOPSEAT KIT LOWERING/RAISING (CONT)

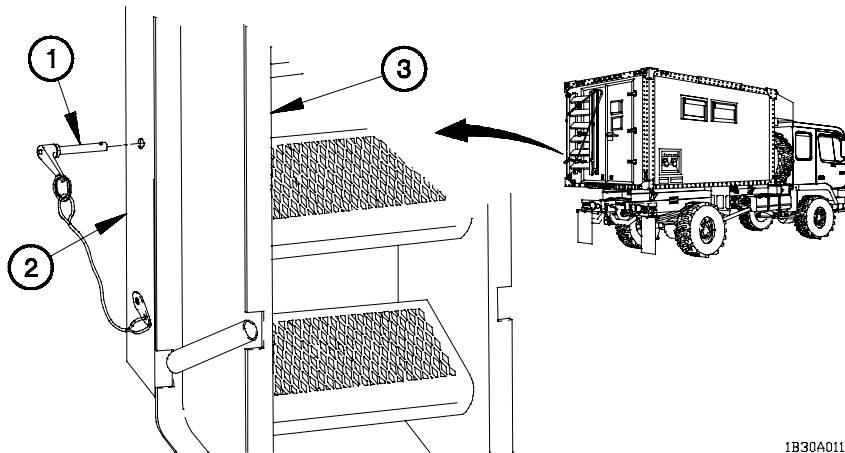


(10) Connect safety strap (1) to left rear seat post (2).

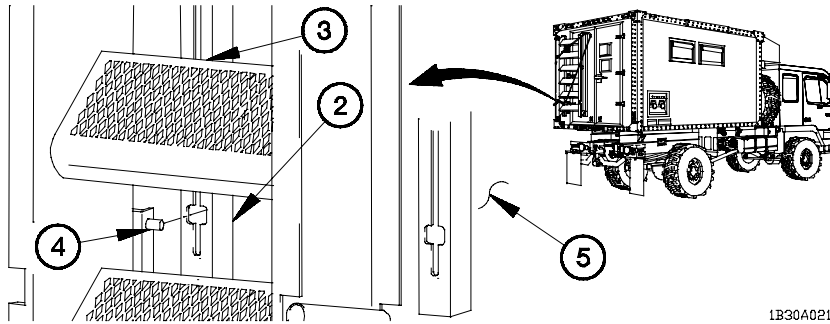
(11) Stow ladder (para 2-26b).

2-30. M1079 VAN LADDER MOUNTING/STOWING

a. Ladder Mounting.



(1) Remove pin (1) from bracket (2) on left side of ladder (3).

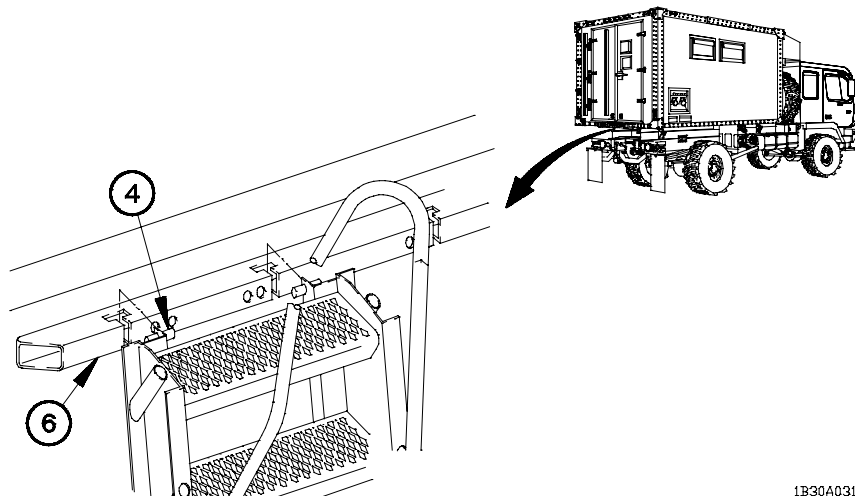


1B30A021

NOTE

Top and bottom of ladder is removed from van body the same way. Lower left side shown.

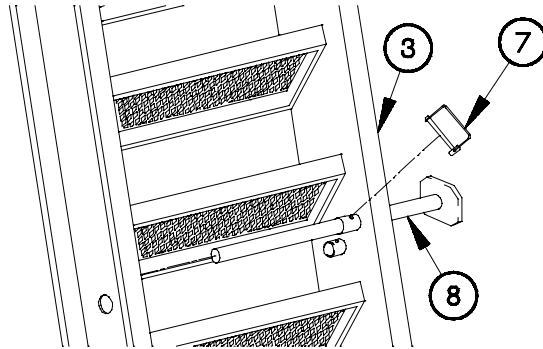
- (2) Raise ladder (3) until two tabs (4) are aligned with slots in brackets (2).
- (3) Remove ladder (3) from two brackets (2).
- (4) Lower ladder (3) until two tabs (4) are aligned with slots in brackets (2).
- (5) Removed ladder (3) from van body (5).



1B30A031

- (6) Install two tabs (4) in bracket (6).

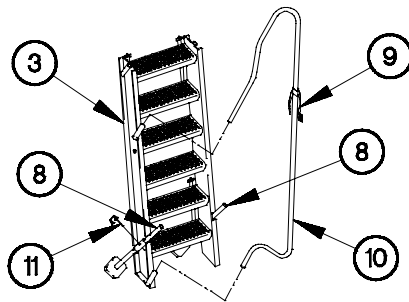
2-30. M1079 VAN LADDER MOUNTING/STOWING (CONT)



NOTE

Left and right handle supports are removed the same way. Left handle support shown.

- (7) Remove pin (7) and handle support (8) from ladder (3).

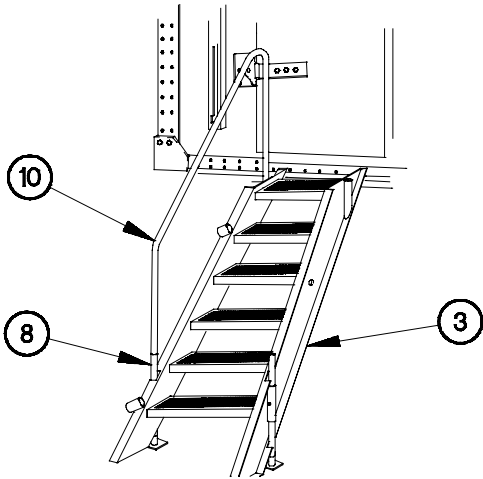


- (8) Remove strap (9) from ladder (3).
- (9) Remove handle (10) from ladder (3).

NOTE

Step (10) requires aid of assistant.

- (10) Raise ladder (3) and install two handle supports (8) on both sides at base of ladder (3).
- (11) Install two pins (11) in two handle supports (8) and ladder (3).



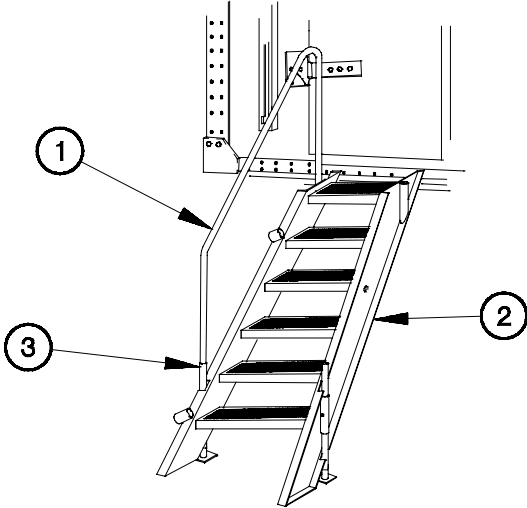
1B30A061

NOTE

Handle can be installed on left or right side of ladder. Left side shown.

(12) Install handle (10) in ladder (3) and over handle support (8).

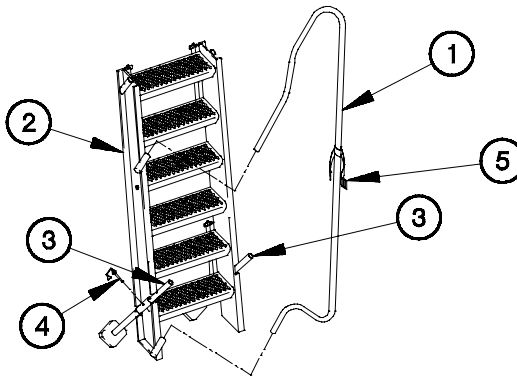
b. Ladder Stowing.



1B30B011

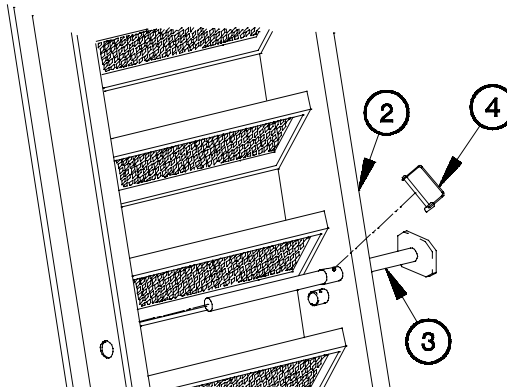
(1) Remove handle (1) from ladder (2) and handle support (3).

2-30. M1079 VAN LADDER MOUNTING/STOWING (CONT)



1B30B021

- (2) Remove two pins (4) from handle supports (3).
- (3) Remove two handle supports (3) from ladder (2).
- (4) Install handle (1) in ladder (2).
- (5) Install strap (5) on ladder (2).

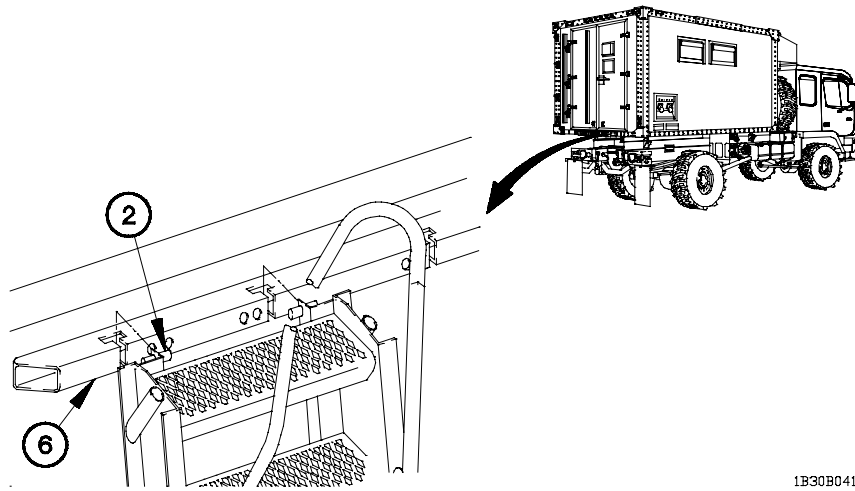


1B30B031

NOTE

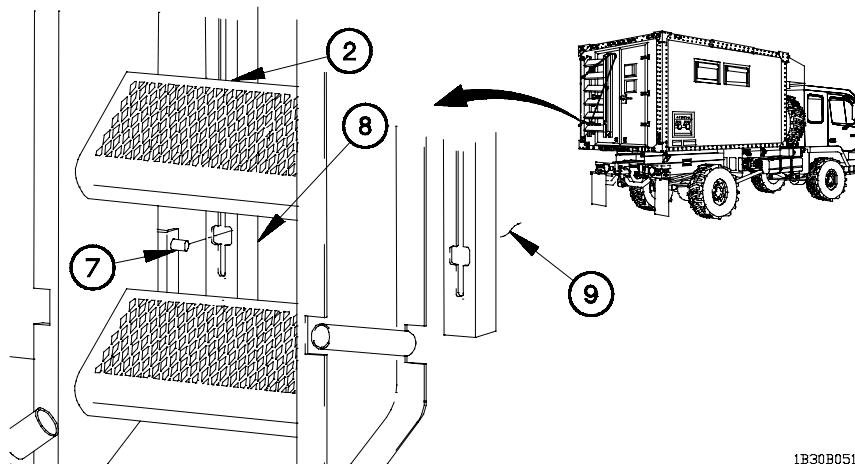
Handle supports are installed on left and right side of ladder the same way. Left side shown.

- (6) Install handle support (3) in ladder (2) with pin (4).



1B30B041

(7) Remove ladder (2) from bracket (6).



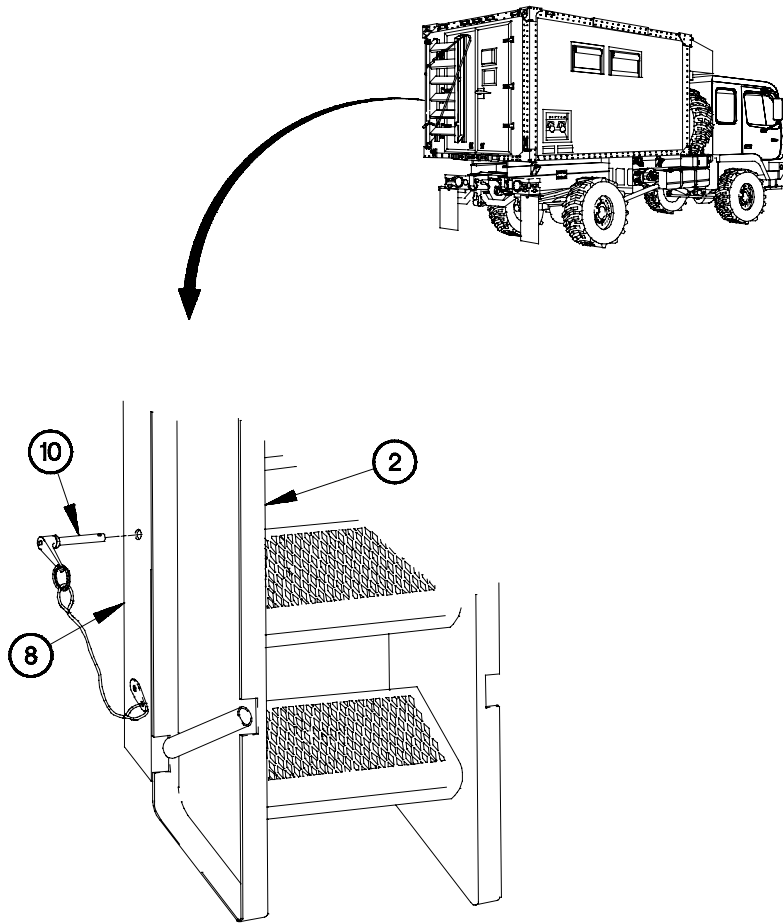
1B30B051

(8) Position two tabs (7) in bracket (8).

(9) Raise ladder (2) up until two tabs (7) are aligned with slots in bracket (8).

(10) Install ladder (2) on van body (9).

2-30. M1079 VAN LADDER MOUNTING/STOWING (CONT)

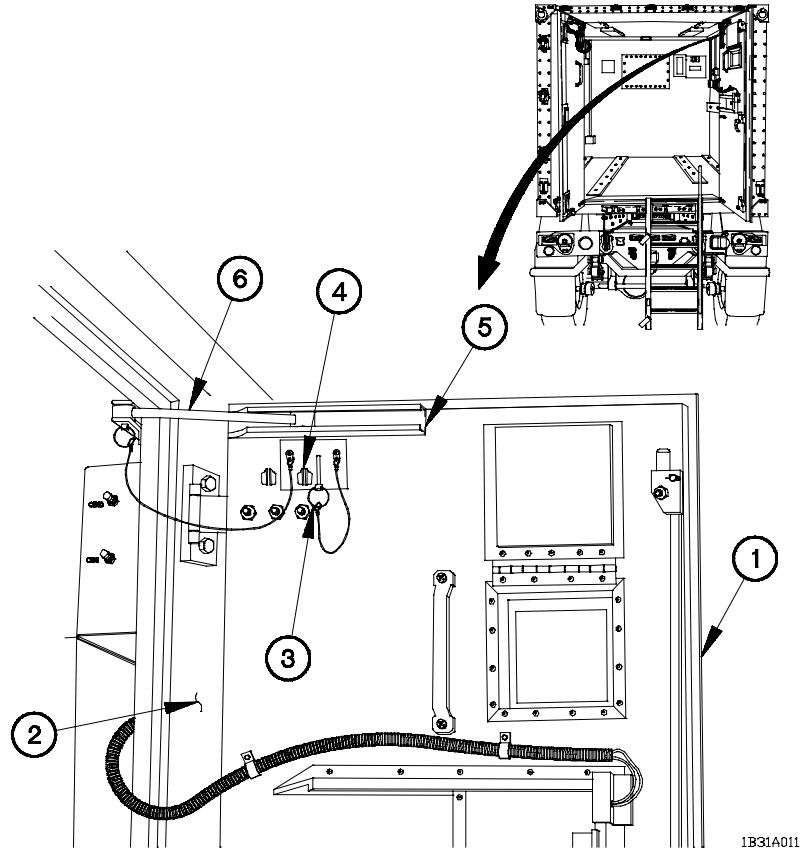


1B30B061

(11) Install pin (10) in bracket (8) on left side of ladder (2).

2-31. M1079 VAN DOORS OPENING/CLOSING

a. Securing Van Doors Open at 115° Position.



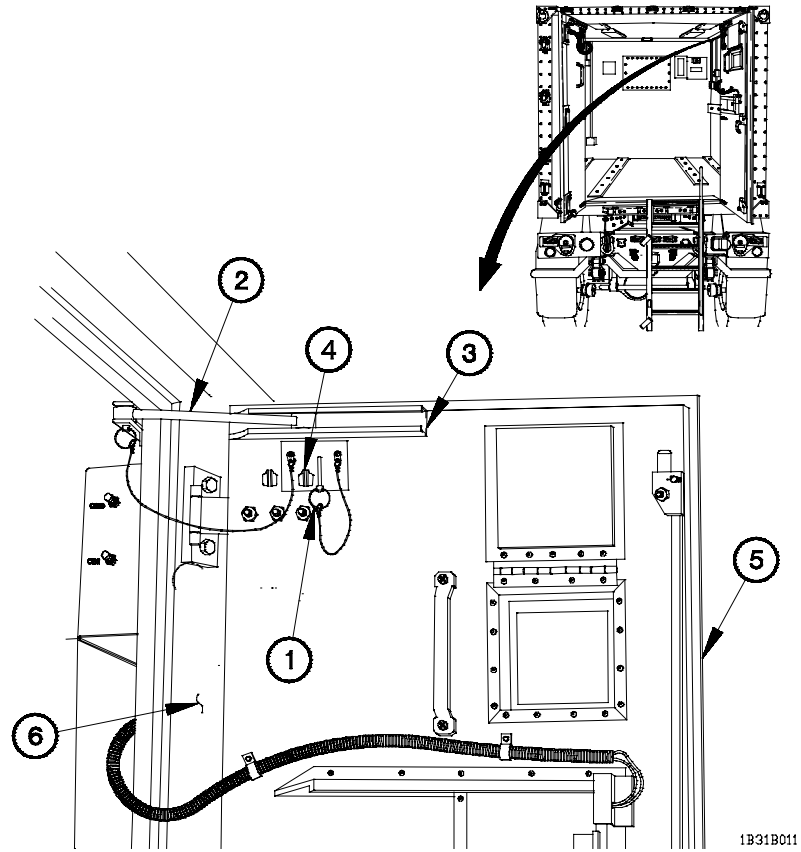
NOTE

LH and RH doors are positioned at 115° the same way. RH door shown.

- (1) Open door (1) on van body (2).
- (2) Remove quick release pin (3) from stowage clip (4).
- (3) Install quick release pin (3) in channel (5) and stay arm (6).

2-31. M1079 VAN DOORS OPENING/CLOSING (CONT)

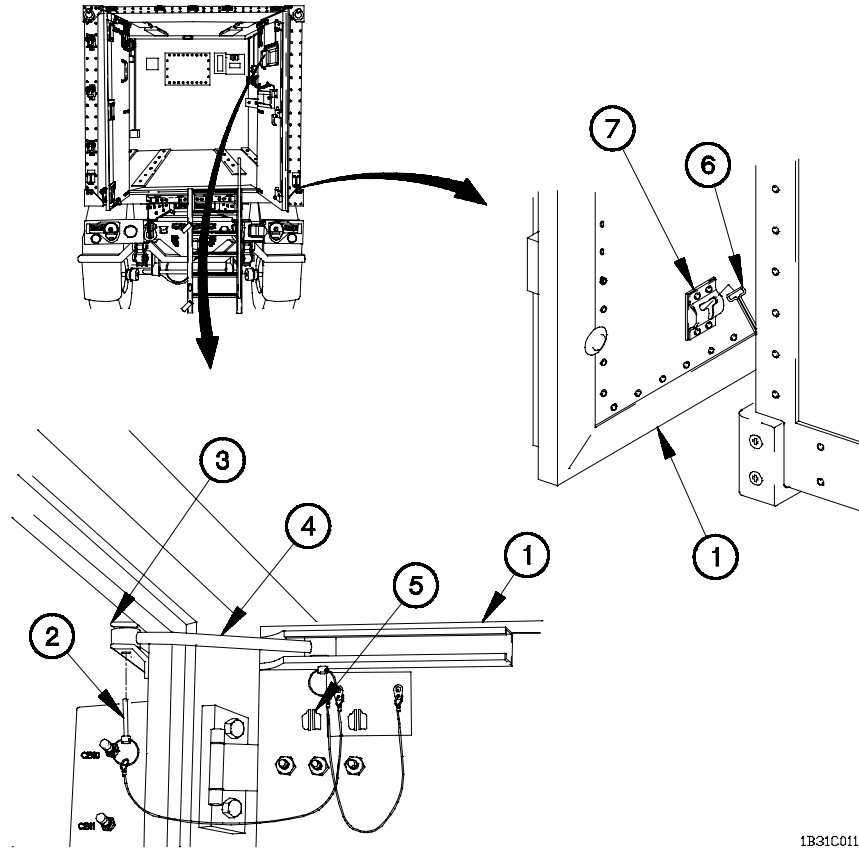
b. Closing Van Doors from 115° Position.



1B31B011

- (1) Remove quick release pin (1) from stay arm (2) and channel (3).
- (2) Install quick release pin (1) in stowage clip (4).
- (3) Close door (5) on van body (6).

c. Securing Van Doors Open at 180° Position.



1B31C011

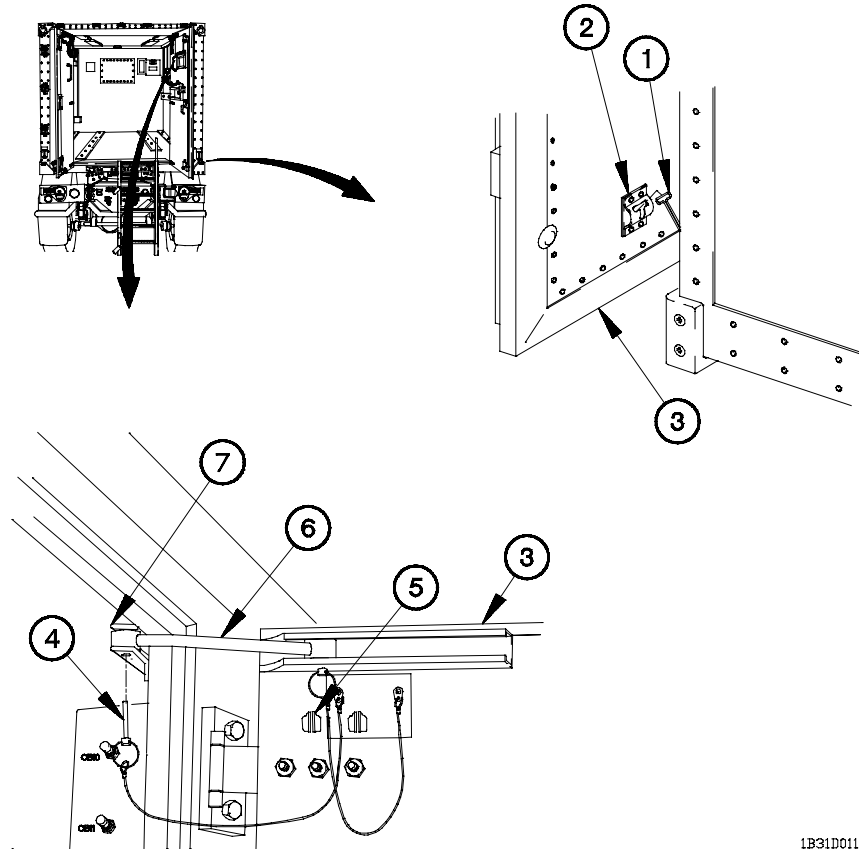
NOTE

LH and RH doors are positioned at 180° the same way. RH door shown.

- (1) Secure door (1) open at 115° position (para 2-31a).
- (2) Remove quick release pin (2) from bracket (3) and stay arm (4).
- (3) Stow quick release pin (2) in stowage clip (5).
- (4) Fully open door (1) to 180° position.
- (5) Install "T" latch (6) in "T" latch receptacle (7) on door (1).

2-31. M1079 VAN DOORS OPENING/CLOSING (CONT)

d. Closing Van Doors from 180° Position.



1B31D011

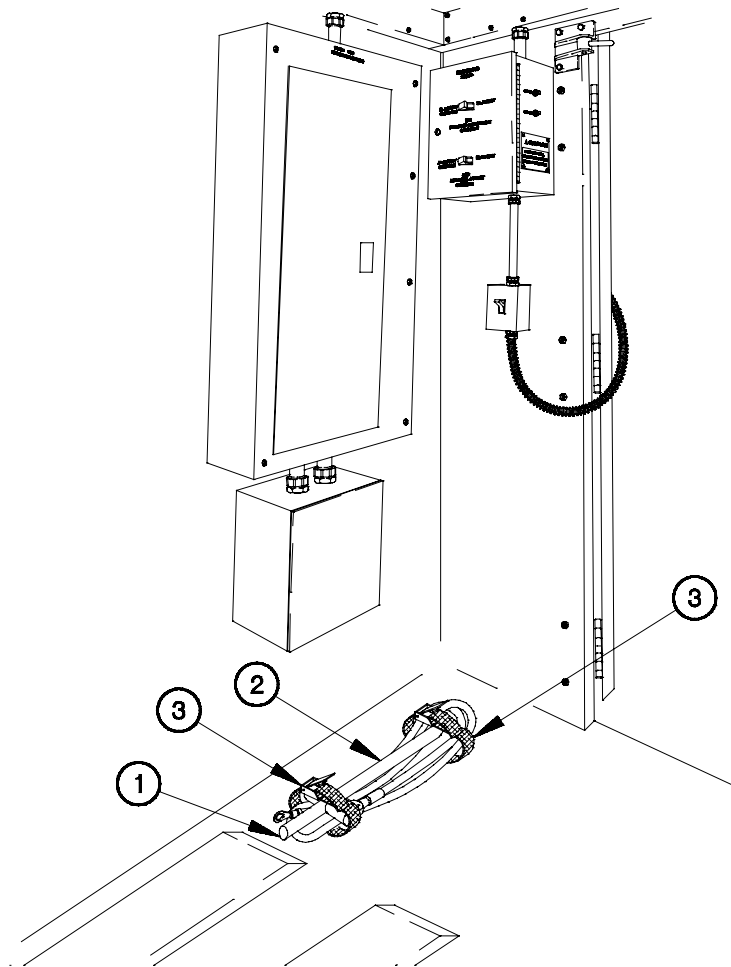
NOTE

LH and RH doors are closed from the 180° open position the same way.
RH door shown.

- (1) Remove "T" latch (1) from "T" latch receptacle (2) on door (3).
- (2) Position door (3) to 115° position.
- (3) Remove quick release pin (4) from stowage clip (5).
- (4) Install stay arm (6) in bracket (7) with quick release pin (4).
- (5) Close door (3) from 115° position (para 2-31b).

2-32. M1079 VAN AC POWER CONNECTING/DISCONNECTING

a. Connect AC Power.

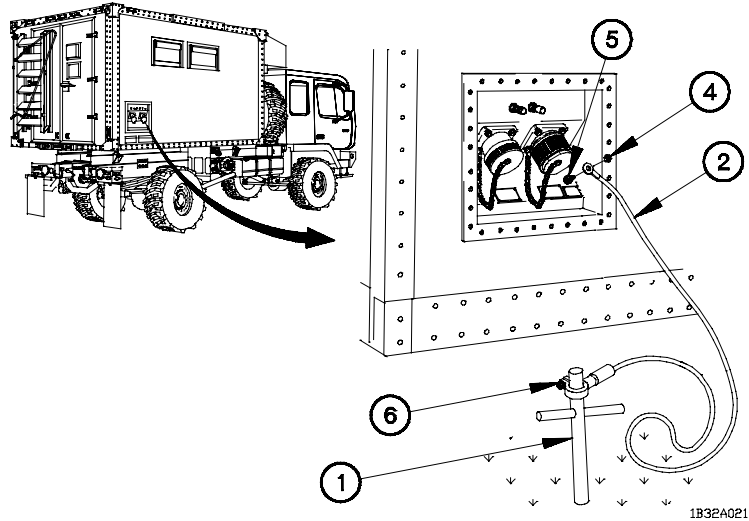


1B32A011

(1) Shut down engine (para 2-21f).

(2) Remove ground rod (1) and ground cable (2) from two straps (3).

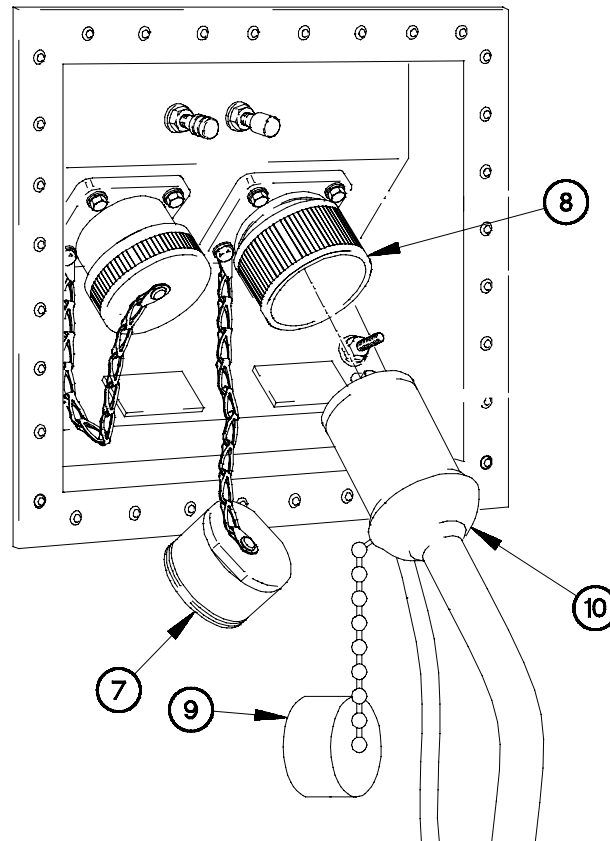
**2-32. M1079 VAN AC POWER CONNECTING/DISCONNECTING
(CONT)**



WARNING

- **Ground rod must be driven into ground 18-24 in. (46-61 cm) and ground cable connected to the chassis before power can be taken from outside source or equipment operated inside van. Failure to comply may result in serious injury or death to personnel or damage to equipment.**
- **Ensure that ground cable terminal makes good metal-to-metal contact with bare metal on van body. If required, scrape contact area clean of dirt, paint, or rust. Failure to comply may result in serious injury or death to personnel or damage to equipment.**

- (3) Drive ground rod (1) into ground.
- (4) Remove nut (4) from ground receptacle (5).
- (5) Install ground cable (2) on ground receptacle (5) with nut (4).
- (6) Position ground cable (2) on ground rod (1).
- (7) Tighten nut (6) on ground cable (2).



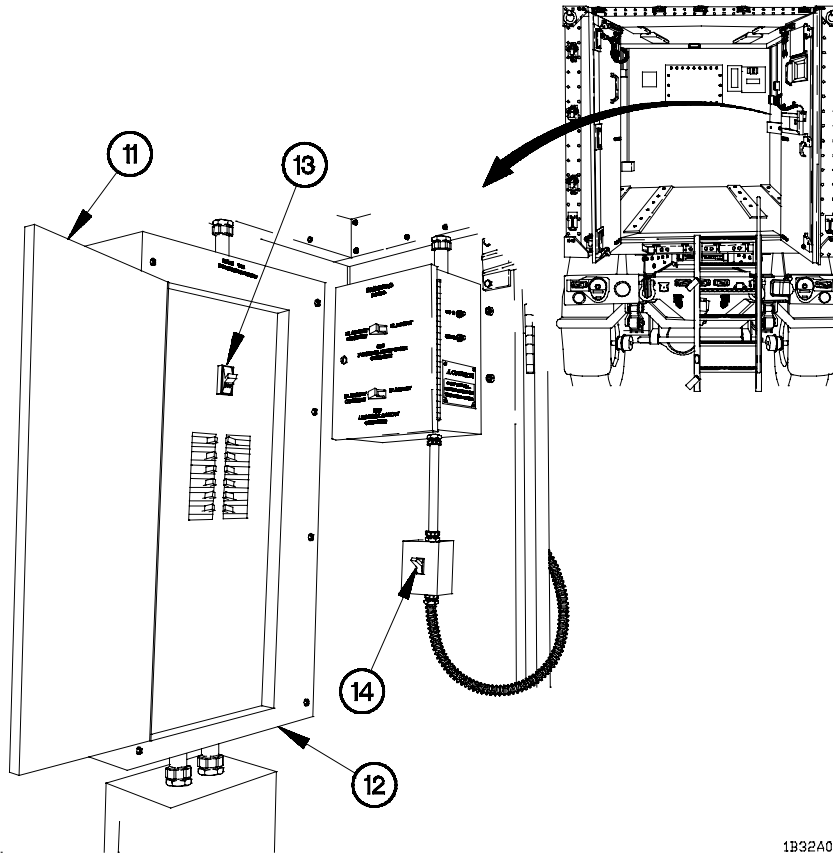
1B32A031

- (8) Remove dust cover (7) from 110/208 vac IN receptacle (8).
- (9) Remove dust cover (9) from AC power cable (10).
- (10) Remove AC power cable (10) from van.
- (11) Connect AC power cable (10) to 110/208 vac IN receptacle (8).

NOTE

- Other equipment may be connected to the 110/208 vac OUT receptacle to share power. Power out from this receptacle is limited to 50 amps.
 - Setup AC power source to supply AC power to van (refer to technical manual of power source).
- (12) Connect other end of AC power cable (10) to AC power source.
 - (13) Turn on AC power source (refer to technical manual of power source).

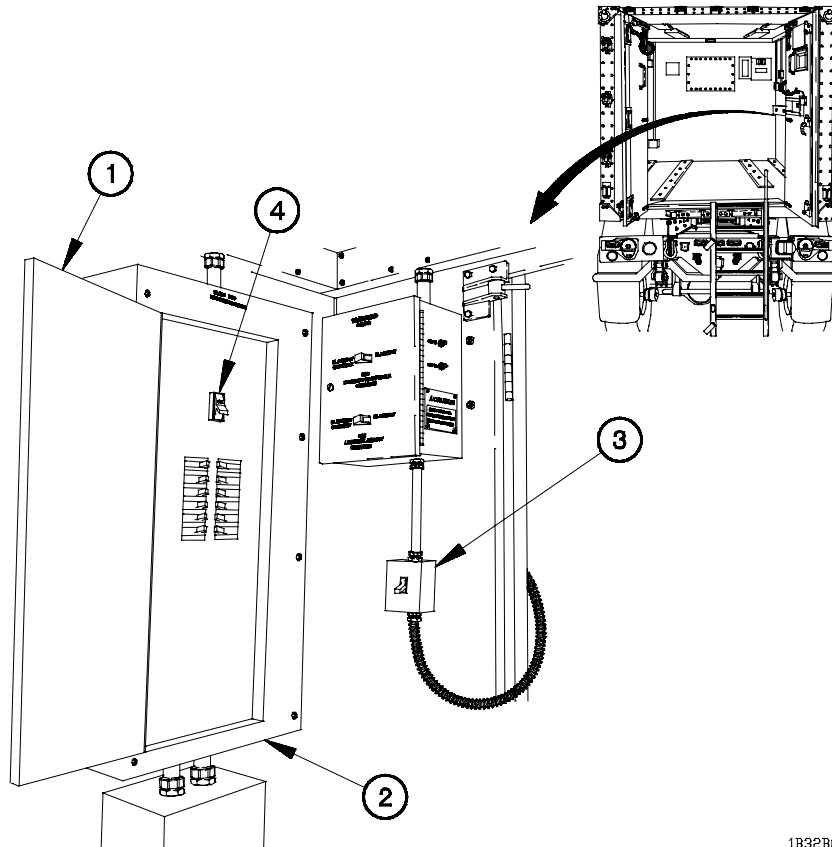
**2-32. M1079 VAN AC POWER CONNECTING/DISCONNECTING
(CONT)**



1B32A041

- (14) Open cover (11) on 110/208 VAC POWER DISTRIBUTION PANEL (12).
- (15) Position MAIN power switch (13) on 110/208 VAC POWER DISTRIBUTION PANEL (12) to ON.
- (16) Position INTERIOR LIGHTS switch (14) to ON.

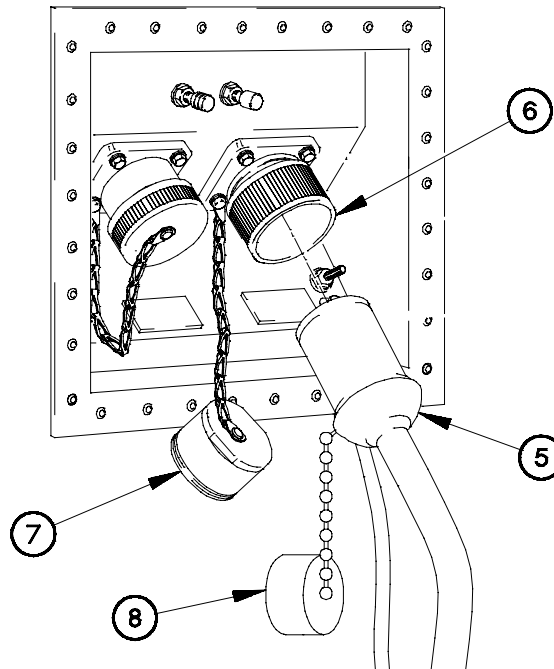
b. Disconnect AC Power.



1B32B011

- (1) Open cover (1) on 110/208 VAC POWER DISTRIBUTION PANEL (2).
- (2) Position INTERIOR LIGHTS switch (3) to OFF.
- (3) Position MAIN power switch (4) on 110/208 VAC POWER DISTRIBUTION PANEL (2) to OFF.

**2-32. M1079 VAN AC POWER CONNECTING/DISCONNECTING
(CONT)**

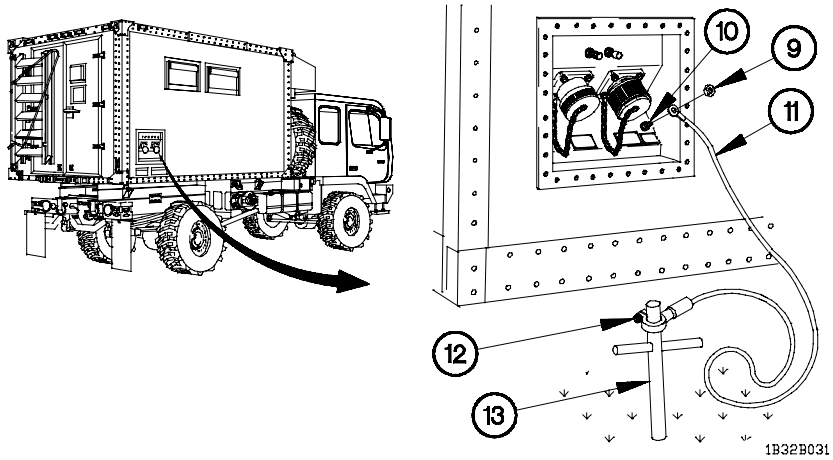


1B32B021

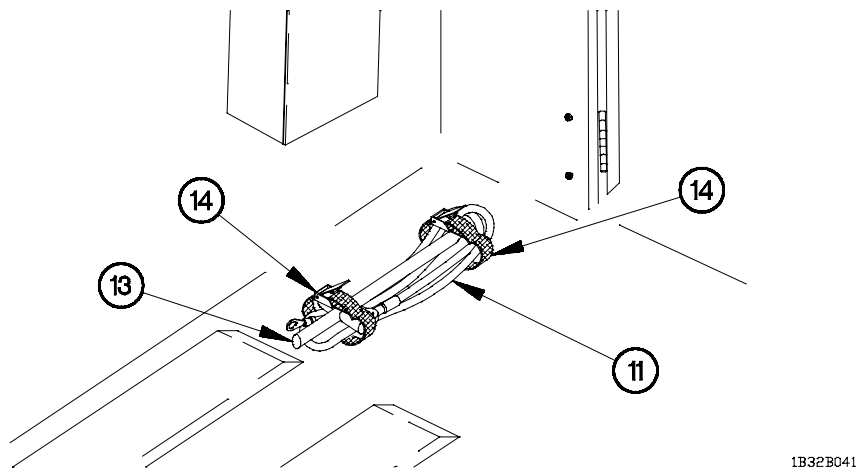
WARNING

Power source must be turned off before disconnecting power cable. Failure to comply may result in serious injury or death to personnel or damage to equipment.

- (4) Turn off AC power source (refer to technical manual of power source).
- (5) Disconnect AC power cable (5) from power source.
- (6) Disconnect other equipment from 110/208 VAC OUT receptacle before disconnecting AC power cable (4) from van.
- (7) Disconnect AC power cable (5) from 110/208 VAC IN receptacle (6).
- (8) Install dust cover (7) on 110/208 vac IN receptacle (6).
- (9) Install dust cover (8) on AC power cable (5).
- (10) Stow AC power cable (5) in van.



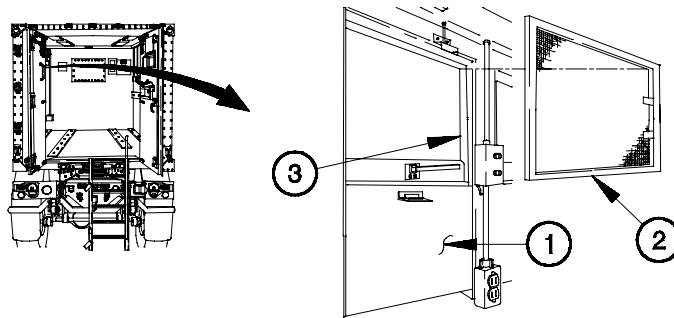
- (11) Remove nut (9) from ground receptacle (10).
- (12) Remove ground cable (11) from ground receptacle (10).
- (13) Install nut (9) on ground receptacle (10).
- (14) Loosen nut (12) and remove ground cable (11) from ground rod (13).
- (15) Remove ground rod (13) from ground.



- (16) Position ground cable (11) and ground rod (13) in two straps (14).
- (17) Tighten two straps (14).

2-33. M1079 VAN WINDOW OPERATION

a. Opening Window.

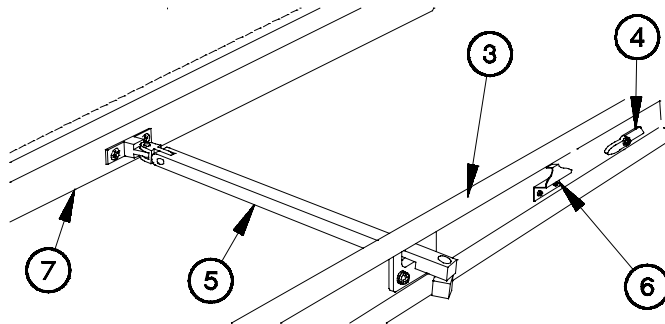


1B33A011

NOTE

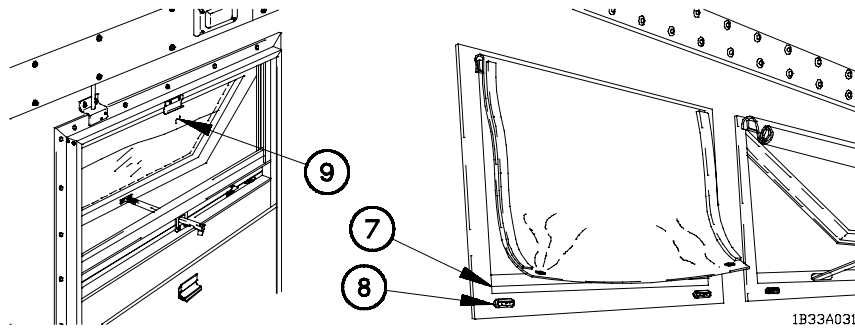
All windows are operated the same way. Left rear window shown.

- (1) Lower blackout shield (1).
- (2) Remove screen (2) from window main frame (3).



1B33A021

- (3) Open TRANSPORT LOCK (4) on window main frame (3).
- (4) Remove prop (5) from latch (6).
- (5) Open window sash assembly (7) to last notch on prop (5) for access.

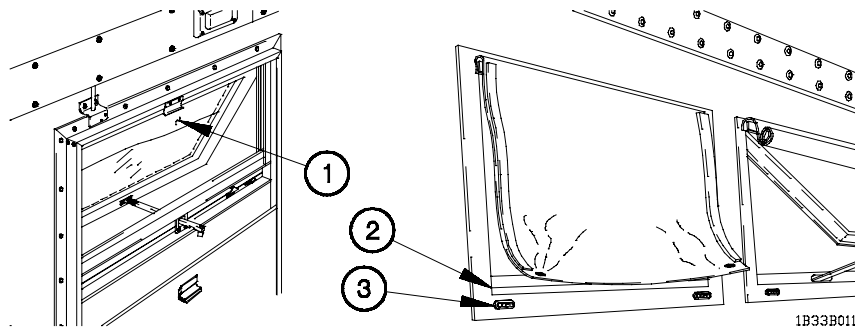


NOTE

To access window cover reach through window opening.

- (6) Unlock two stud fasteners (8) from window cover (9).
- (7) Roll window cover (9) upward from window sash assembly (7).

b. Closing Window.

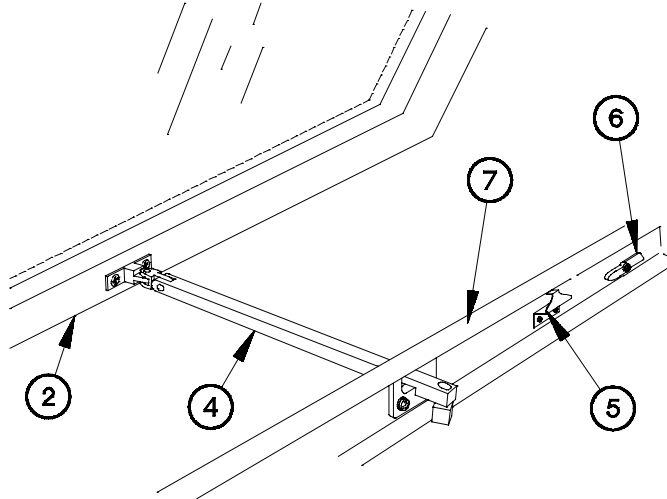


NOTE

To access window cover reach through window opening.

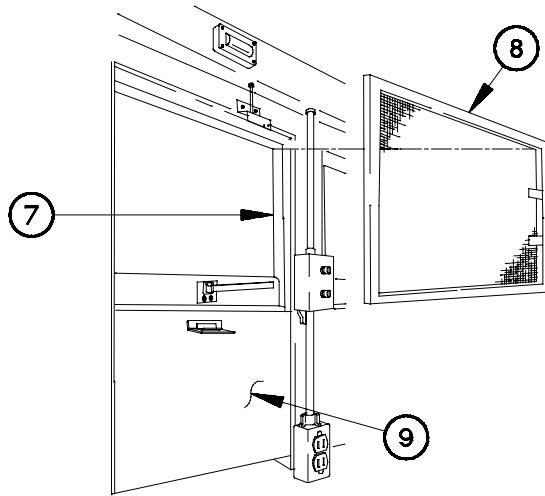
- (1) Unroll window cover (1) downward over window sash assembly (2).
- (2) Lock two stud fasteners (3) on window cover (1).

2-33. M1079 VAN WINDOW OPERATION (CONT)



1B33B021

- (3) Close window sash assembly (2).
- (4) Position prop (4) in latch (5).
- (5) Close TRANSPORT LOCK (6) on window main frame (7).

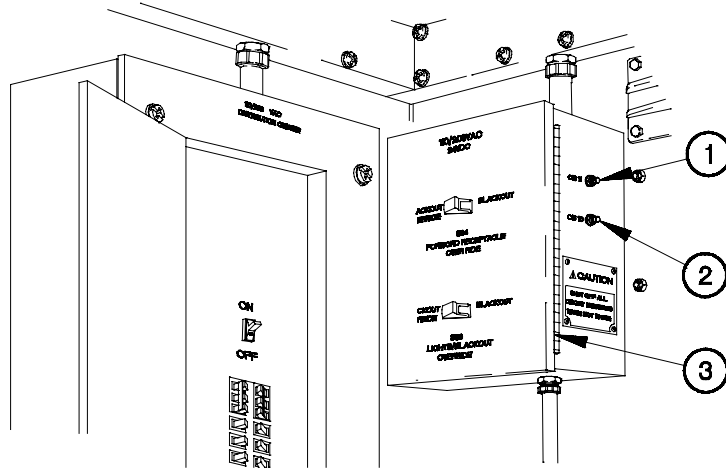


1B33B031

- (6) Install screen (8) in window main frame (7).
- (7) Raise blackout shield (9).

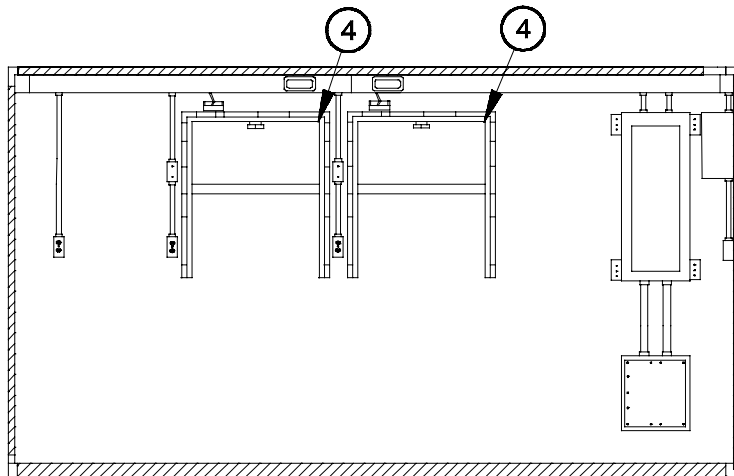
2-34. M1079 VAN LIGHTING

a. Interior Lighting.



1B34A011

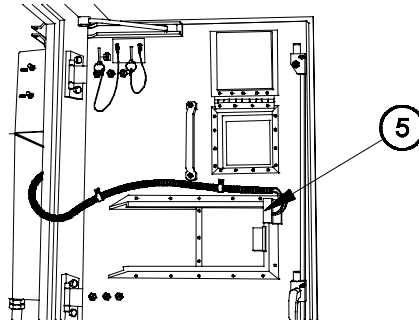
- (1) Shut down engine (para 2-21f).
- (2) Connect AC power (para 2-32).
- (3) Push in CB11 (1) and CB10 (2) on relay panel (3).



1B34A021

- (4) Close four blackout shields (4).

2-34. M1079 VAN LIGHTING (CONT)

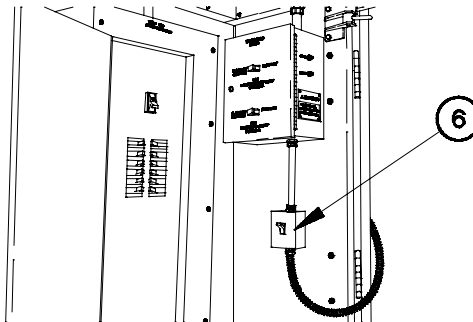


1B34A031

NOTE

Perform step (5) on van body serial number 190 and higher.

- (5) Close RH door window (5).
- (6) Close and latch LH and RH doors (para 2-31b or d).



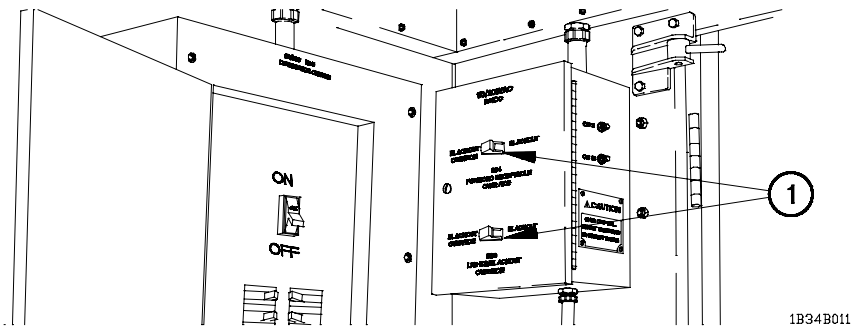
1B34A041

NOTE

- Interior lights will not illuminate with doors, windows, or blackout shields open.
- With loss of DC power, four emergency lights (white) will illuminate, with both doors and blackout shields closed.

- (7) Position INTERIOR LIGHTS switch (6) to on.

b. Blackout Override.



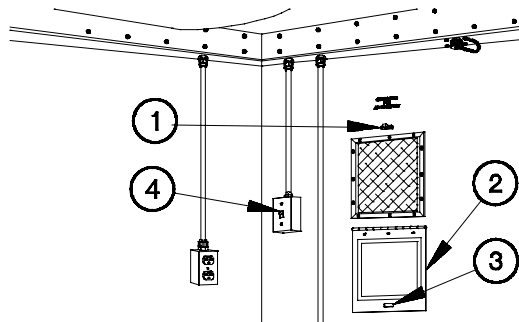
NOTE

- During blackout override only two forward AC outlets (J232 and J233) will have power.
- When either door or any blackout shield is open, van will not have AC power unless activating BLACKOUT OVERRIDE switches.

Position BLACKOUT OVERRIDE switches (1) to ON.

2-35. M1079 VAN FAN OPERATION

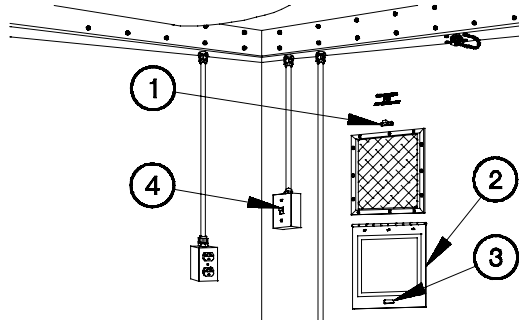
a. Turning Fan On.



- (1) Unlock top stud fastener (1).
- (2) Open fan cover (2) and position on bottom stud fastener (3).
- (3) Lock bottom stud fastener (3).
- (4) Position FAN switch (4) to ON.

2-35. M1079 VAN FAN OPERATION (CONT)

b. Turning Fan Off.

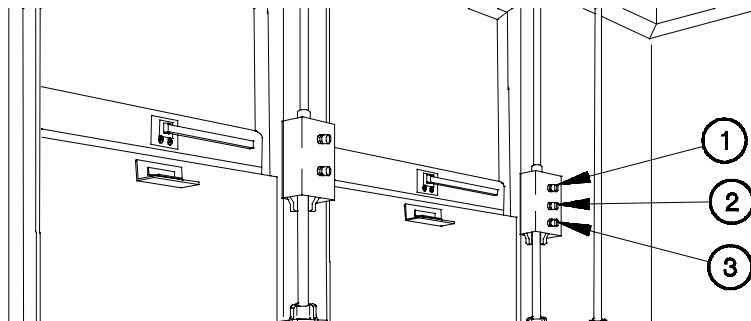


1B35B011

- (1) Position FAN switch (4) to OFF.
- (2) Unlock bottom stud fastener (3).
- (3) Close fan cover (2) and position on top stud fastener (1).
- (4) Lock top stud fastener (1).

2-36. M1079 VAN 24 VDC BINDING POST OPERATION

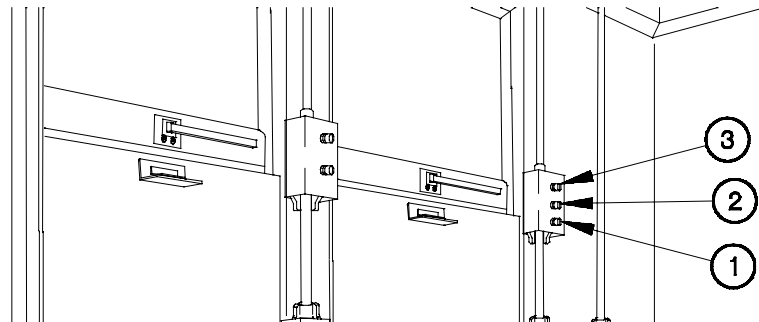
a. Connecting 24 vdc Binding Posts.



1B36A011

- (1) Connect positive wire to 24 vdc POS binding post (1).
- (2) Connect negative wire to 24 vdc NEG binding post (2).
- (3) Connect ground wire to 24 vdc GND binding post (3).

b. Disconnecting 24 vdc Binding Posts.

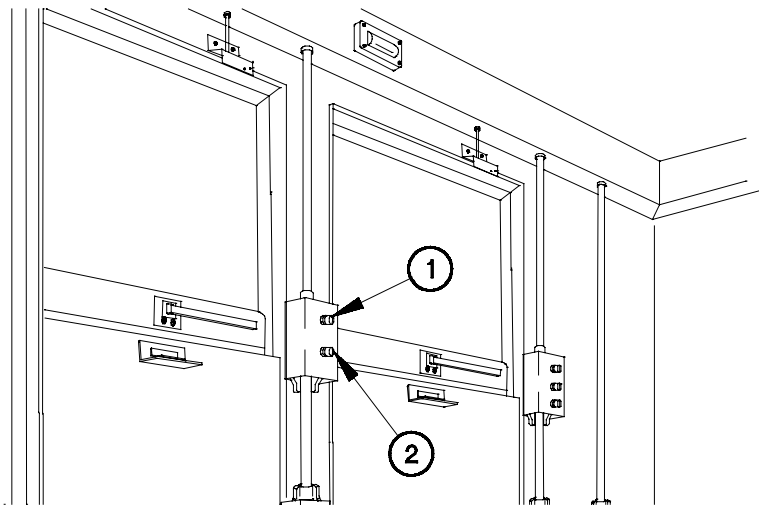


1B36B011

- (1) Disconnect ground wire from 24 vdc GND binding post (1).
- (2) Disconnect negative wire from 24 vdc NEG binding post (2).
- (3) Disconnect positive wire from 24 vdc POS binding post (3).

2-37. M1079 VAN FIELD PHONE BINDING POST OPERATION

a. Connecting Field Phone Binding Posts.

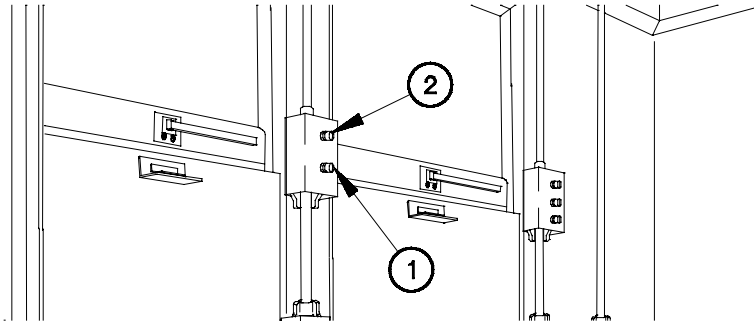


1B37A011

- (1) Connect positive wire to field PHONE POS binding post (1).
- (2) Connect negative wire to field PHONE NEG binding post (2).

**2-37. M1079 VAN FIELD PHONE BINDING POST OPERATION
(CONT)**

b. Disconnecting Field Phone Binding Posts.

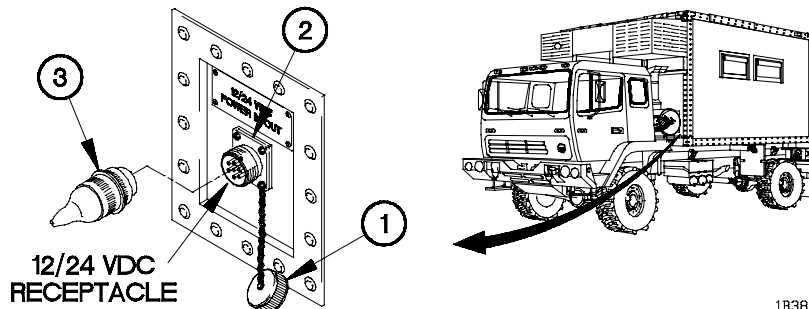


1B37B011

- (1) Disconnect negative wire from field PHONE NEG binding post (2).
- (2) Disconnect positive wire from field PHONE POS binding post (1).

**2-38. M1079 VAN 12/24 VDC POWER
CONNECTION/DISCONNECTION**

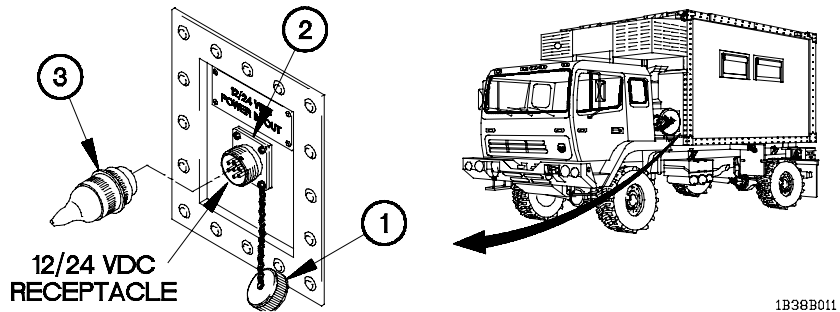
a. Connecting 12/24 vdc Power.



1B38A011

- (1) Remove dust cap (1) from 12/24 vdc power receptacle (2).
- (2) Connect 12/24 vdc power cable (3) to 12/24 vdc power receptacle (2).

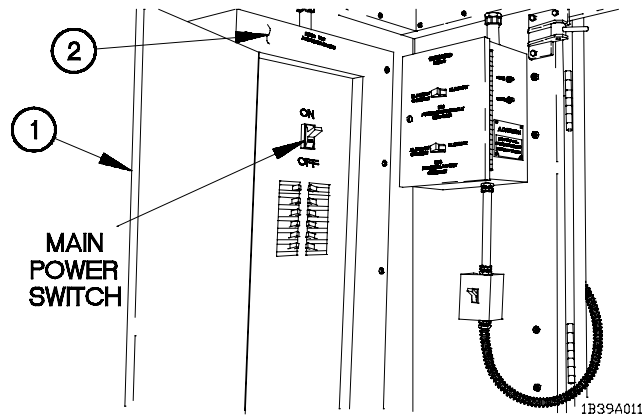
b. Disconnecting 12/24 vdc Power.



- (1) Disconnect 12/24 vdc power cable (3) from 12/24 vdc power receptacle (2).
- (2) Install dust cap (1) on 12/24 vdc power receptacle (2).

2-39. M1079 VAN AIR CONDITIONER/HEATER OPERATION

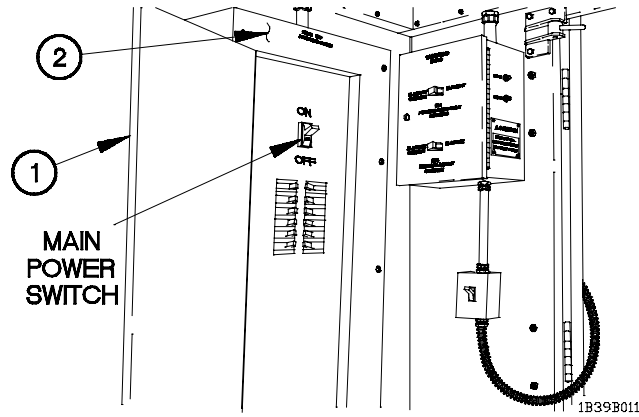
a. Air Conditioner Operation.



- (1) Open cover (1) on 110/208 VAC POWER DISTRIBUTION PANEL (2).
- (2) Position main power switch to ON.
- (3) Refer to TM 5-4120-384-14, Operator's Organizational, Direct Support and General Support Maintenance Manual.

2-39. M1079 VAN AIR CONDITIONER/HEATER OPERATION

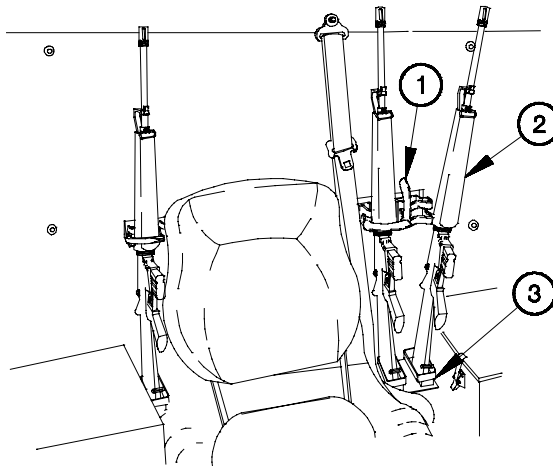
b. Heater Operation.



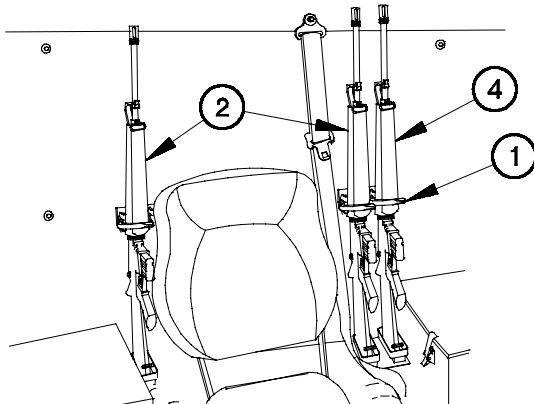
- (1) Open cover (1) on 110/208 VAC POWER DISTRIBUTION PANEL (2).
- (2) Position main power switch to ON.
- (3) Refer to TM 5-4520-253-13, Operator's, Unit, and Intermediate Maintenance Manual.

2-40. AUXILIARY EQUIPMENT OPERATION

a. Stow Rifle in Mount.



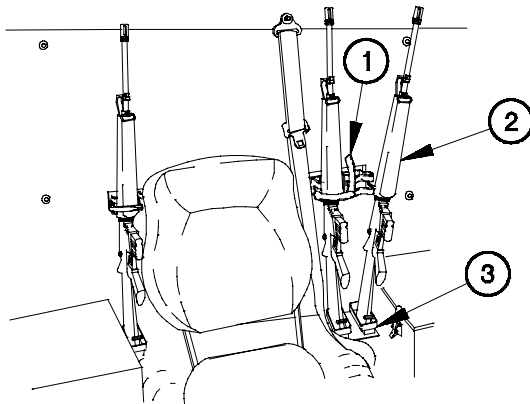
- (1) Turn handle (1) up.
- (2) Position rifle (2) in support (3).



1B40A021

- (3) Pull out on handle (1).
- (4) Turn handle (1) down over rifle handguard (4).
- (5) Check that rifle (2) is secure.
- (6) Perform steps (1) through (5) for remaining rifles (2).

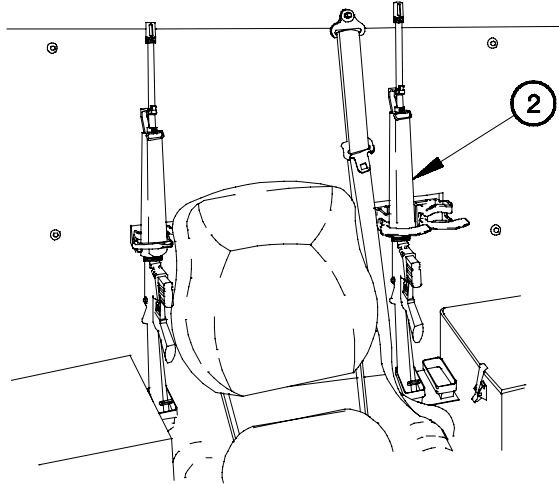
b. Remove Rifle from Mount.



1B40B011

- (1) Pull out on handle (1).
- (2) Turn handle (1) up.
- (3) Remove rifle (2) from support (3).

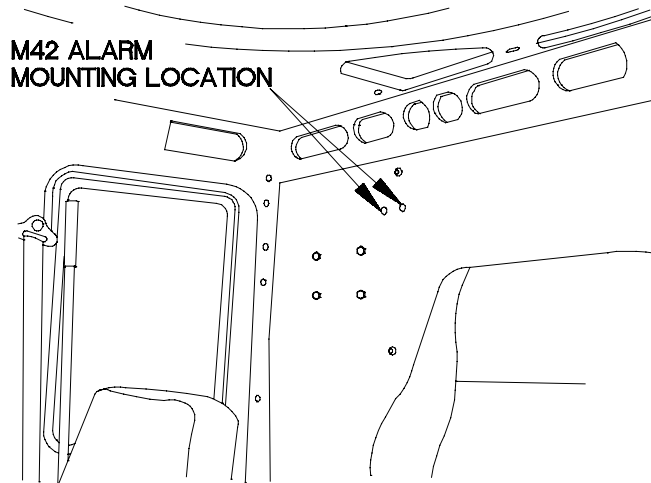
2-40. AUXILIARY EQUIPMENT OPERATION (CONT)



1B40B021

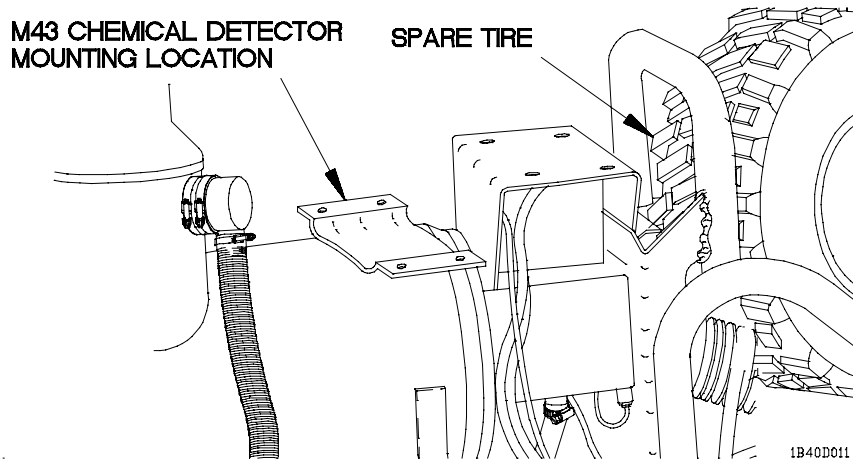
(4) Perform steps (1) through (3) for remaining rifles (2).

c. M42 Alarm Mounting Location.

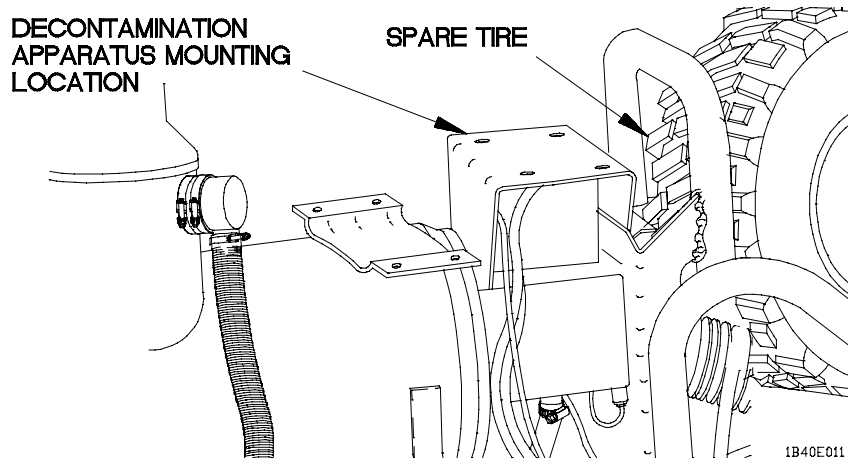


1B40C011

d. M43 Chemical Detector Mounting Location.



e. Decontamination Apparatus Mounting Location.



f. Operate Chemical Alarm Kit.

Refer to TM 3-6665-225-12 for operating instructions.

g. Operate Decontamination Kit.

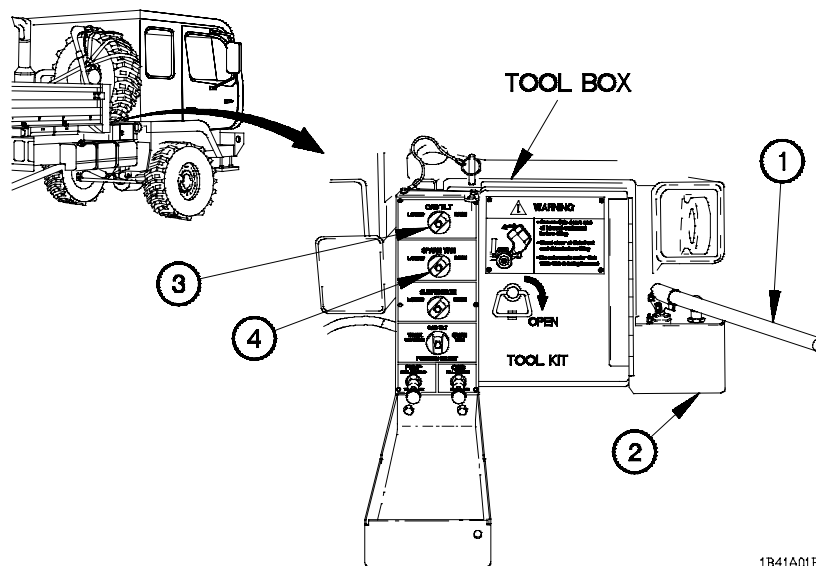
Refer to TM 3-4320-214-12&P for operating instructions.

2-40. AUXILIARY EQUIPMENT OPERATION (CONT)

h. Operate Radio.

Radio equipment will be mounted in cab on rear panel, Refer to TM 11-5820-401-10-1 (AN/VRC-46) or TM 11-5820-890-10-1 (AN/VCR-90) for operating instructions.

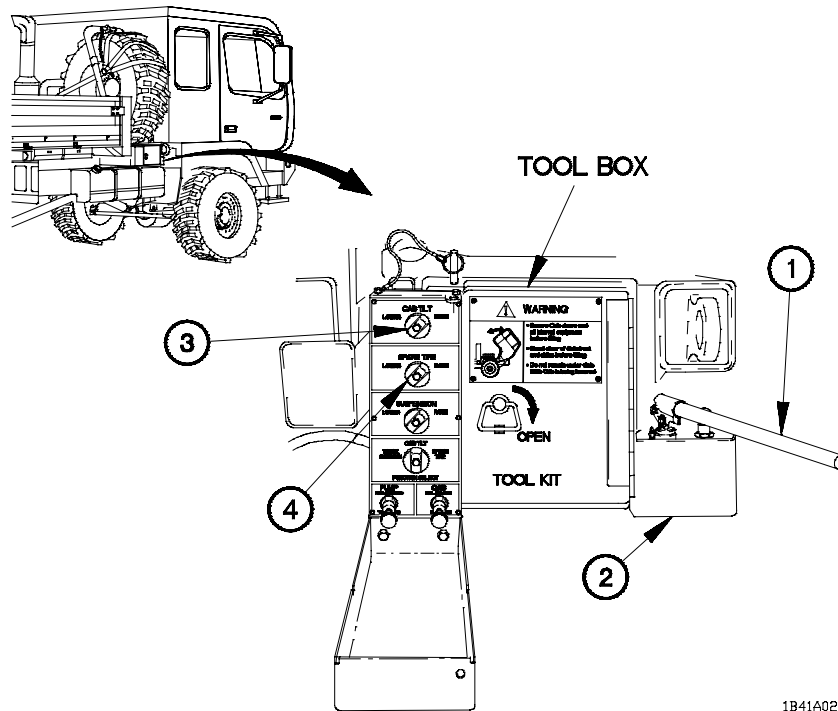
2-41. BACK-UP HYDRAULIC PUMP OPERATION



- (1) Remove handle (1) from tool box.
- (2) Insert handle (1) in back-up hydraulic pump (2).
- (3) Pump handle (1) until cab or spare tire is in desired position.

NOTE

- If cab or spare tire does not move, perform steps (4) through (7).
 - If performing steps (4) through (7) does not accomplish the required action, notify Unit Maintenance.
- (4) Turn CAB TILT (3) or SPARE TIRE (4) knob to the opposite position.



1B41A02B

NOTE

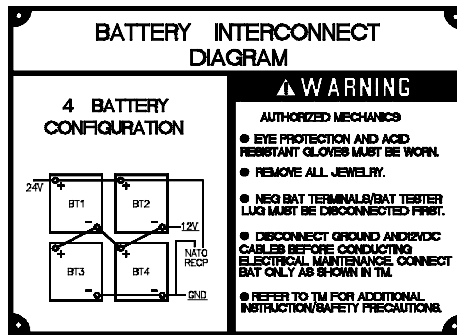
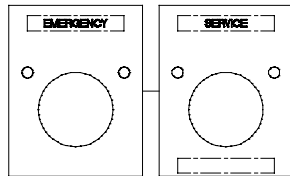
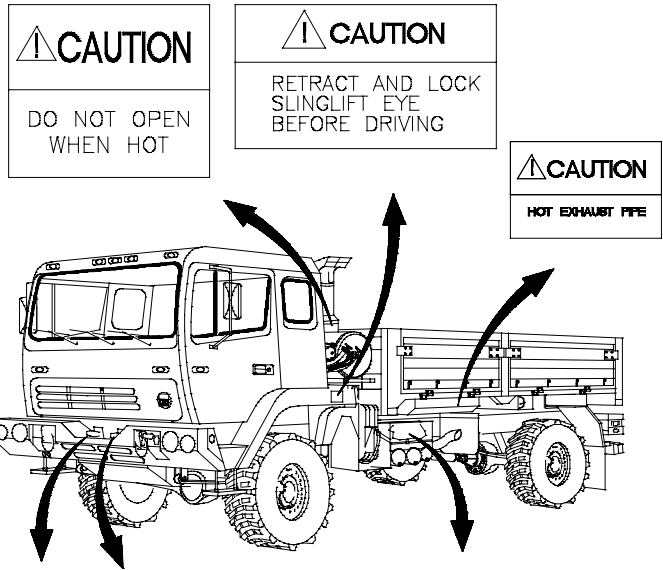
- It may be necessary to perform step (5) several times before cab or spare tire begins to move.
 - A downward cycle should take approximately 3 seconds.
- (5) Pump handle (1) slowly downward until cab or spare tire moves a few inches.
 - (6) Turn CAB TILT (3) or SPARE TIRE (4) knob to the opposite position.
 - (7) Pump handle (1) until cab or spare tire is in required position.
 - (8) Place pump handle (1) in down position.
 - (9) Remove handle (1) from back-up hydraulic pump (2).
 - (10) Stow handle (1) in tool box.

2-42. DATA AND INSTRUCTION PLATES

WARNING


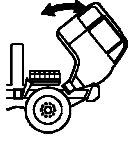
Data and instruction plates given below must be followed at all times to safely operate vehicle. Failure to comply may result in injury to personnel or damage to equipment.

a. All Vehicles, Left Side.

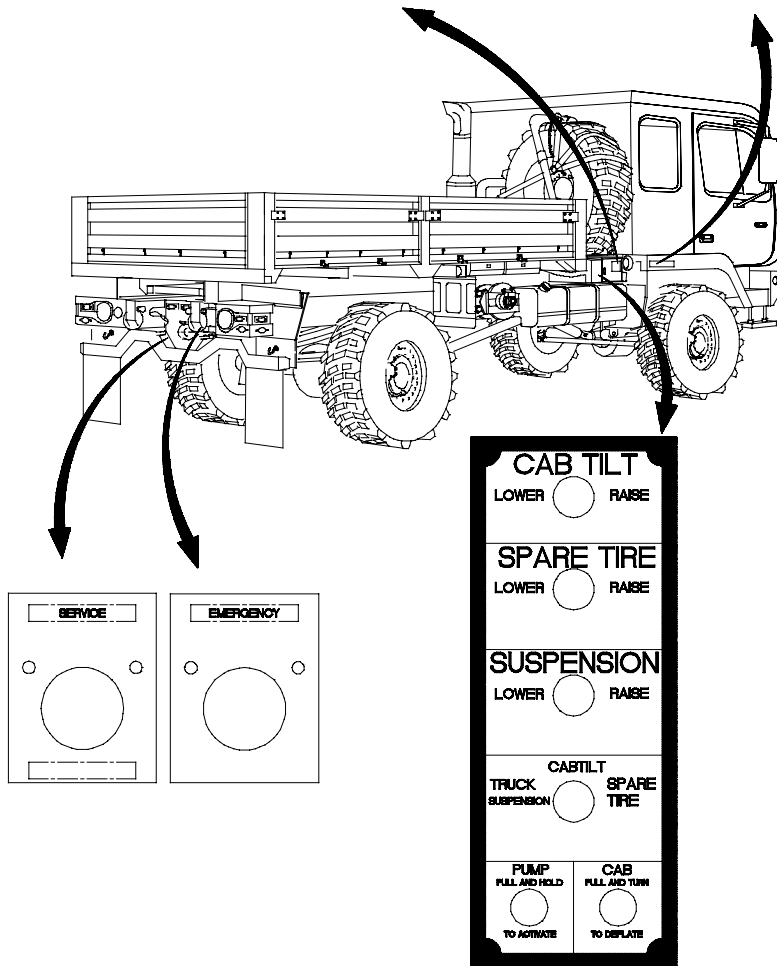


1B42A01B

b. All Vehicles, Right Side.

	WARNING
	<ul style="list-style-type: none"> • SECURE CAB DOORS AND ALL INTERNAL EQUIPMENT BEFORE TILTING • STAND CLEAR OF CAB FRONT AND SIDES BEFORE TILTING • DO NOT REMAIN UNDER CAB WHILE CAB IS BEING LOWERED

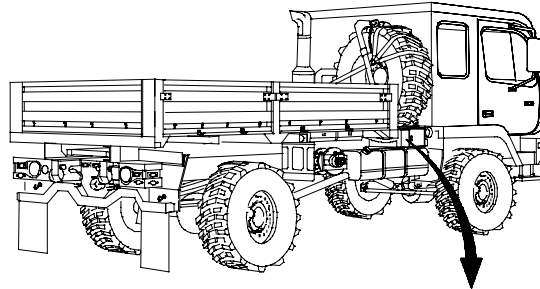
	CAUTION
RETRACT AND LOCK SLING LIFTEYE BEFORE DRIVING	



1B4EB011

2-42. DATA AND INSTRUCTION PLATES (CONT)

b. All Vehicles, Right Side (Cont).



⊕	CAB	⊕
	<p>RAISE</p> <ol style="list-style-type: none"> 1. ENSURE DOORS ARE SECURE AND PERSONNEL AND EQUIPMENT ARE AWAY FROM CAB FRONT. 2. SELECT "CAB TILT" FUNCTION. 3. SELECT CAB TILT "RAISE". 4. PRESS AND HOLD "PUMP" SWITCH UNTIL CAB MOVES PAST THE OVER-CENTER POSITION. <p>LOWER</p> <ol style="list-style-type: none"> 1. ENSURE ALL TOOLS AND EQUIPMENT ARE REMOVED FROM ENGINE COMPARTMENT AND OFF TIRES. 2. SELECT "CAB TILT" FUNCTION. 3. SELECT CAB TILT "LOWER". 4. PRESS AND HOLD "PUMP" SWITCH UNTIL CAB MOVES PAST OVER-CENTER AND LET CAB FREE-FALL TO LATCH. 5. ENSURE CAB LOCK IS FULLY RETRACTED. 	
	SPARE TIRE	
	<p>LOWER</p> <ol style="list-style-type: none"> 1. REMOVE SPARE TIRE RETAINING STRAP. 2. SELECT "SPARE TIRE" FUNCTION. 3. SELECT SPARE TIRE "LOWER". 4. PUSH AND HOLD "PUMP" SWITCH UNTIL SPARE TIRE IS OVER-CENTER THEN ALLOW TIRE TO FREE-FALL TO GROUND. <p>RAISE</p> <ol style="list-style-type: none"> 1. INSTALL SPARE TIRE IN CARRIER. 2. SELECT "SPARE TIRE" FUNCTION. 3. SELECT SPARE TIRE "RAISE". 4. PUSH AND HOLD "PUMP" SWITCH UNTIL TIRE IS FULLY SEATED IN THE CARRIER. 5. INSTALL SPARE TIRE RETAINING STRAP. 	
	SUSPENSION	
⊕	<p>LOWER</p> <ol style="list-style-type: none"> 1. SET PARK BRAKE, START ENGINE AND LET IDLE. 2. OPEN TIRE VALVES TO DEFLATE FRONT TIRES. 3. RAISE CAB. 4. REMOVE SAFETY PINS FROM CYLINDERS AND REMOVE CHAINS FROM STOWAGE POSITION. 5. SELECT "TRUCK SUSPENSION" FUNCTION. 6. SELECT SUSPENSION "RAISE". 7. PUSH AND HOLD "PUMP" SWITCH UNTIL CHAINS ALIGN WITH PINS ON AXLE. 8. SECURE CHAINS TO AXLE WITH LYNCH PINS. 9. SELECT SUSPENSION "LOWER". 10. PUSH AND HOLD "PUMP" SWITCH UNTIL CYLINDER IS RETRACTED. INSTALL LOCK PINS. 11. LOWER CAB, DEFLATE AND SECURE AIR SPRINGS. <p>RAISE</p> <ol style="list-style-type: none"> 1. SET PARK BRAKE, START ENGINE AND LET IDLE. 2. CLOSE TIRE VALVES, SELECT CITS "RUN FLAT" AND "HIGHWAY" AT THE SAME TIME. 3. INFLATE CAB AIR SPRINGS BY REMOVING PINS THEN PUSH IN AND TURN "CAB" KNOB. STOW PINS. 4. SELECT "TRUCK SUSPENSION" FUNCTION. 5. SELECT SUSPENSION "LOWER". 6. PUSH AND HOLD "PUMP" SWITCH UNTIL CYLINDER LOCKING PINS CAN BE REMOVED. RAISE CAB IF NEEDED. 7. SELECT SUSPENSION "RAISE". 8. PUSH AND HOLD "PUMP" SWITCH UNTIL CHAINS CAN BE REMOVED FROM AXLE PINS. 9. RELEASE HOLD-DOWN CHAINS ON EACH SIDE OF FRONT SUSPENSION BY REMOVING LYNCH PINS. 10. SELECT SUSPENSION "LOWER". 11. PUSH AND HOLD "PUMP" SWITCH UNTIL CYLINDER IS RETRACTED. 12. SECURE CYLINDER WITH LOCKING PINS. 13. STOW CHAINS WITH LYNCH PINS. LOWER CAB IF RAISED.⊕ 	⊕

1B42B021

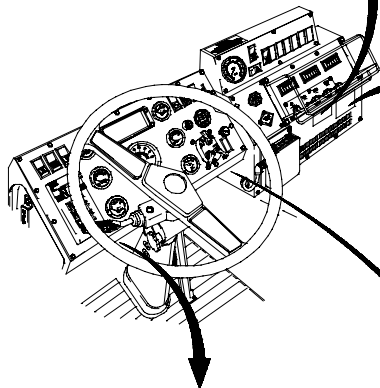
c. All Vehicles, Interior.

VEHICLES SN 0001 THROUGH 3091

	STOP ENGINE WARNING		LOW OIL PRESSURE WARNING
	HIGH BEAM ON		HIGH ENGINE TEMPERATURE WARNING
	TURN SIGNAL		PTO ENGAGED
			RADIATOR FAN OFF

VEHICLES SN 0001 THROUGH 3091

	ENGINE PREHEAT		ROTARY WARNING BEACON
	TROOP HEATER		RADIATOR FAN OFF
	HORN		HAZARD WARNING
	WINDSHIELD WIPERS		IGNITION
	ETHER START		WINCH CONTROL
	FUEL PREHEAT		PTO ENGAGED
	A/C HEATER		WORK LIGHTS



TRUCK, CARGO LMTV, W/W, M-1078	
NATIONAL STOCK NO.	2320-01-050-8608
CONTRACT NO.	DAAE07-92-O-1001
MANUFACTURED BY	STEWART + STEVENSON SERVICES, INC. TACTICAL VEHICLE SYSTEMS DIVISION SEELY, TEXAS 77474
CAGE NO. OFWSB	
VEN/USA	
MFG. SERIAL NO.	
MFG. DATE	
DELIVERY DATE	
INSPECTED	U.S. PROPERTY

WARRANTY	
This vehicle is covered by a material and workmanship warranty for a period of 18 months or 12,000 miles which ever occurs first from the date of acceptance for the components identified below.	
Entire Vehicle As Delivered	National Stock Number
Warranty claim procedures must be followed by the user to secure warranty service for those components or major assemblies covered by the warranty agreement. Contact the local Warranty Control Office (WARCO) and provide an accurate description of the problem along with the vehicle NSN, serial number and mileage. The Government may implement repairs and Invoice Tactical Vehicle Systems or TVS will arrange for replacement or repair.	
NOTE: The Government will not submit any claims in which the combined parts and labor costs does not exceed \$150.00 for any single Depot/QS part failure. For warranty action, complete a DA Form 2407 or DA Form 5804 and submit as instructed in the Warranty Program Technical Bulletin for this vehicle.	
Warranty Begins:	Date (yymm) Miles
Warranty Ends:	
CAGE CODE OFWSB	Tactical Vehicle Systems Stewart and Stevenson Services, Inc. P.O. Box 380 5000 I-10 West Seely, Texas 77474

1B42C011

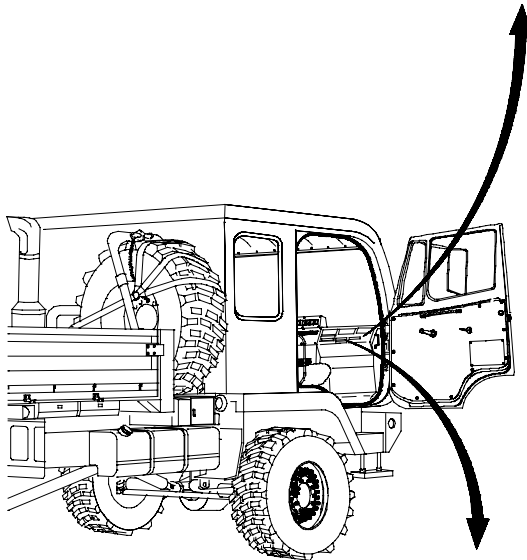
2-42. DATA AND INSTRUCTION PLATES (CONT)

c. All Vehicles, Interior (Cont).



WARNING

- NEVER LEAVE CAB WHILE ENGINE IS RUNNING UNLESS TRANSMISSION IS IN NEUTRAL AND PARKING BRAKES ARE SET
- USE WHEEL CHOCKS ON UNEVEN SURFACES

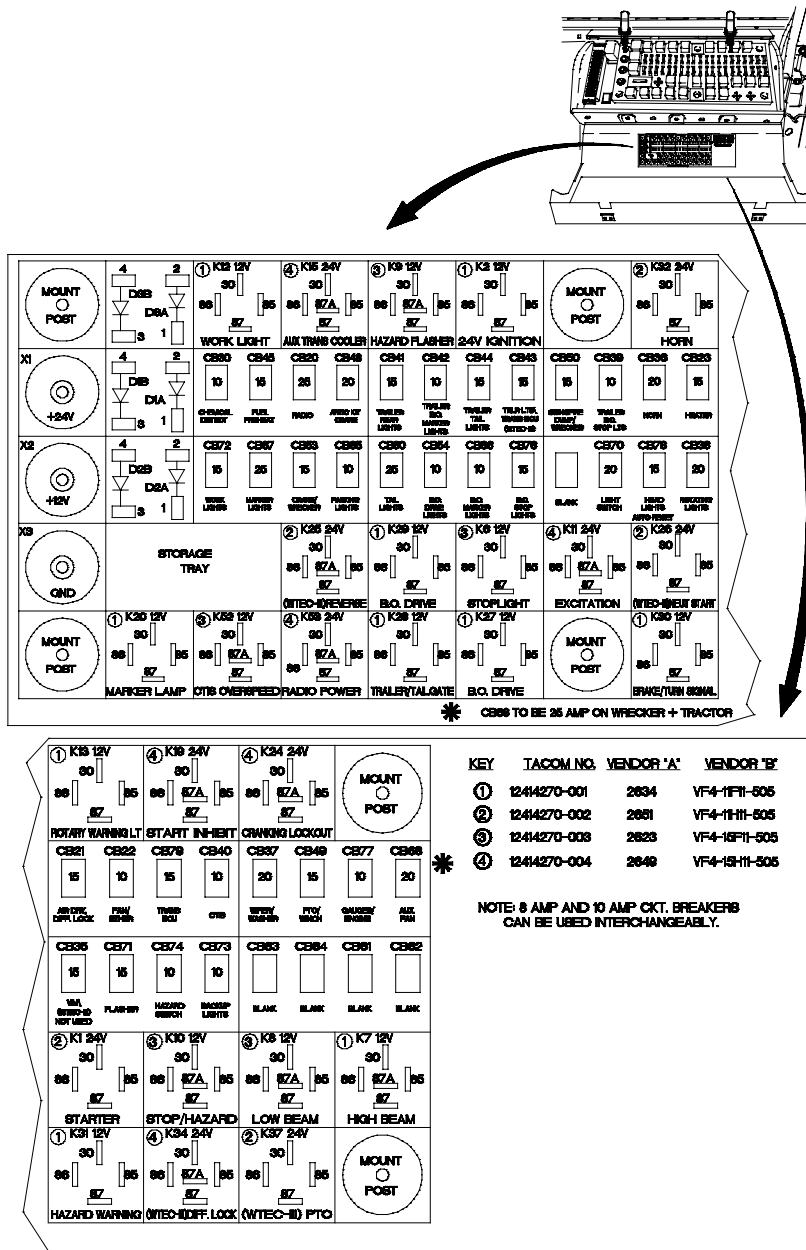


CAUTION

- DISENGAGE FAN CLUTCH WHEN FORDING MORE THAN 20 INCHES DEEP
- OBSERVE ENGINE TEMPERATURE GAUGE TO PREVENT ENGINE OVERHEATING
- AFTER FORDING REENGAGE FAN CLUTCH

1B42C021

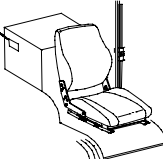
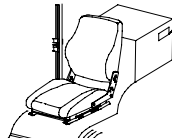
c. All Vehicles Interior (Cont).



1B42C03B

c. All Vehicles, Interior (Cont).

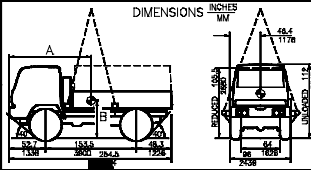
DRIVER'S SIDE STORAGE BOX	
QTY	ITEM
6	NBC OVERGARMENT SUITS
6 PR	NBC GLOVES
3	NBC HOODS

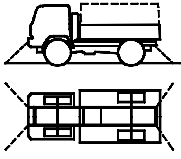
CO-DRIVER'S SIDE STORAGE BOX	
QTY	ITEM
1	M9 CHEM AGENT DETECTOR PAPER
6 PR	NBC OVERBOOTS
3	NBC MASKS
1	M256 PORTABLE DETECTOR KIT
1	FIRST AID KIT

WEIGHT AND DIMENSIONAL DATA
TRUCK, CARGO: LMTV, M-1078

DIMENSIONS



TIE-DOWN SCHEMATIC

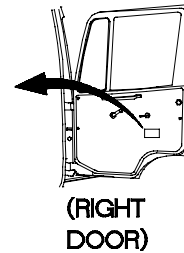


SHIPPING CUBAGE: 1882 CU FT / 44.8 CU M

NOTE: TO REDUCE CAB HEIGHT REFER TO AIR TRANSPORT PROCEDURES IN TM 9-2320-365-10.

WEIGHTS	FRONT AXLE			REAR AXLE			TOTAL WEIGHT		C G DISTANCE		MAXIMUM PAYLOAD 2.5 TONS/2268 KG
	LB	KG		LB	KG		IN	MM	A	B	
CURB	10992	4986	6224	2823	17216	7809	110	2795	50	1270	TIRE DATA MAXIMUM COLD PRESSURE 65 PSI MAXIMUM SPEED 55 MPH/88 KMH
GROSS	11969	5429	10247	4648	22216	10077	125	3175	55	1400	

NOTE: ONLY USE TIE-DOWN POINTS SHOWN ABOVE.



(TYPICAL)

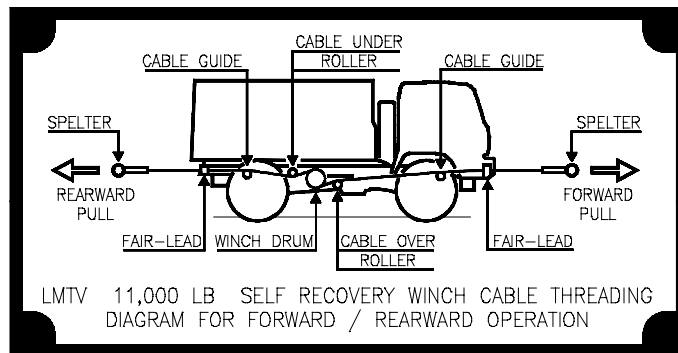
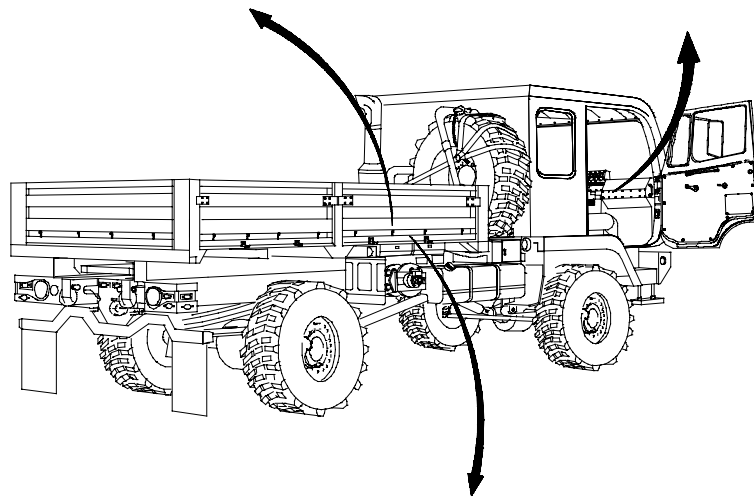
1B42C031

2-42. DATA AND INSTRUCTION PLATES (CONT)

d. Vehicles With 11K Self-Recovery Winch (SRW).

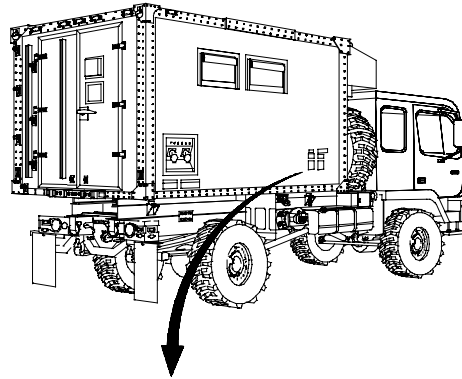
⚠ WARNING
KEEP CLEAR OF CABLE
DURING RECOVERY

⚠ CAUTION
- DO NOT PAY OUT CABLE BEYOND
MARKER AT FAIR-LEAD
- DURING HYDRAULIC OPERATIONS KEEP
ENGINE RPM BETWEEN 1250 AND 1450



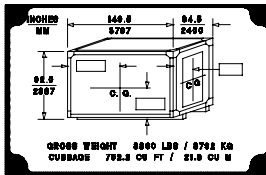
1B42D011

e. M1079 Exterior.

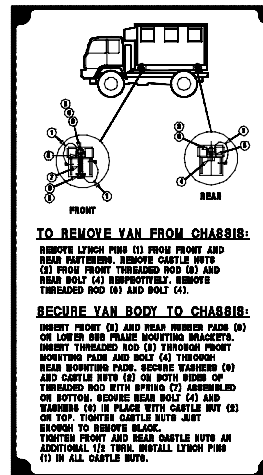
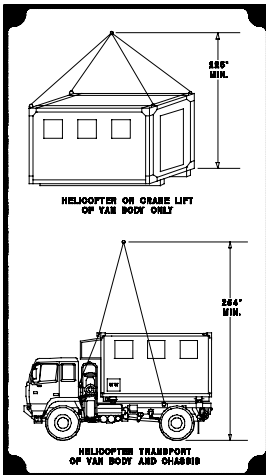


**KEEP DRAIN PLUG LOOSE
DURING AIR AND RAIL
TRANSPORT**

VAN, SHOP, M1079
 ASN. 2810-01-876-1479
 CONTRACT NO. DALE07-82-C-R001
 WFF-87718 DSON ACT-18207
 PART NO. 12416748
 DELIVERY DATE [REDACTED]
 SERIAL NO. [REDACTED]
U.S. PROPERTY



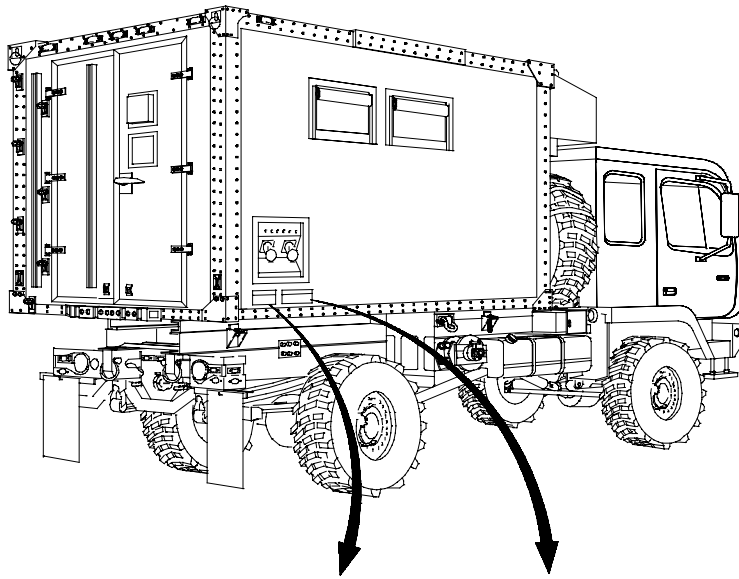
**THE SURFACE OF THIS SHELTER
HAS BEEN PAINTED WITH**
CARC
FOR TOUCH-UP
 EXTERIOR-USE ONLY LITTLENBERG GREEN 988
 POLYURETHANE 100 MIL-C-28789
 INTERIOR-USE ONLY EPOXY PLOYAMIDE
 100 MIL-C-28789



1B42E011

2-42. DATA AND INSTRUCTION PLATES (CONT)

e. M1079 Exterior (Cont).

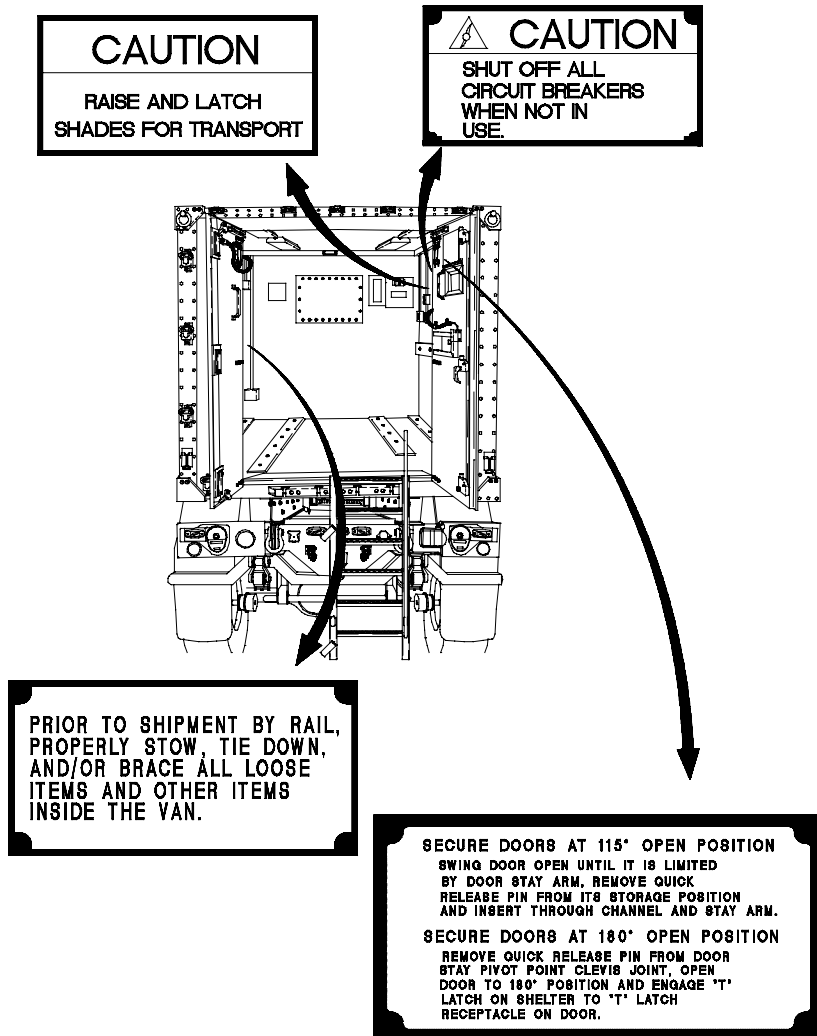


CAUTION
110/208 VAC 3-PHASE
4 WIRE POWER
ONLY

WARNING
GROUND BODY THROUGH
GROUND ROD BEFORE
CONNECTING POWER PLUG

1B42E021

f. M1079 Interior.



1B42F011

Section IV. OPERATION UNDER UNUSUAL CONDITIONS

This section provides instructions to operate the LMTV and its auxiliary equipment under extreme and unusual conditions. Special operating instructions are provided for these conditions.

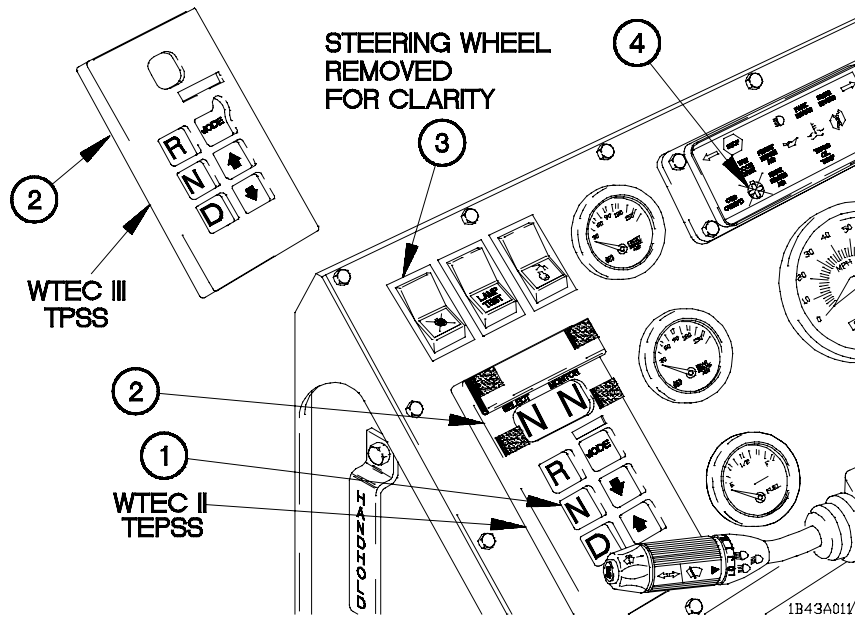
2-43. OPERATION IN EXTREME HEAT

WARNING

When required to remain inside the vehicle during extreme heat, occupants should follow the water intake, work/rest cycle, and other heat stress preventive medicine measures contained in FM 21-10 Field Hygiene and Sanitation, and FM 21-11 First Aid for Soldiers. Failure to comply may result in serious injury or death to personnel.

CAUTION

- When operating in temperatures above 100° F (38° C), extra care must be taken to prevent overheating the engine. Watch WATER TEMP gage, STOP indicator, and engine coolant temperature indicator closely. Failure to comply may result in damage to equipment.
- Check oil levels often and keep operating strain as low as possible. Vehicle cooling and lubrication systems support each other. Failure of one system will rapidly cause failure of the other system. Failure to comply may result in damage to equipment.
- Idle engine to cool down. Idling cools engine faster than quick shutdown and may prevent damage to engine from excessive heat. Failure to comply may result in damage to equipment.



CAUTION

Use low gear ranges only when necessary. Failure to comply may result in damage to equipment.

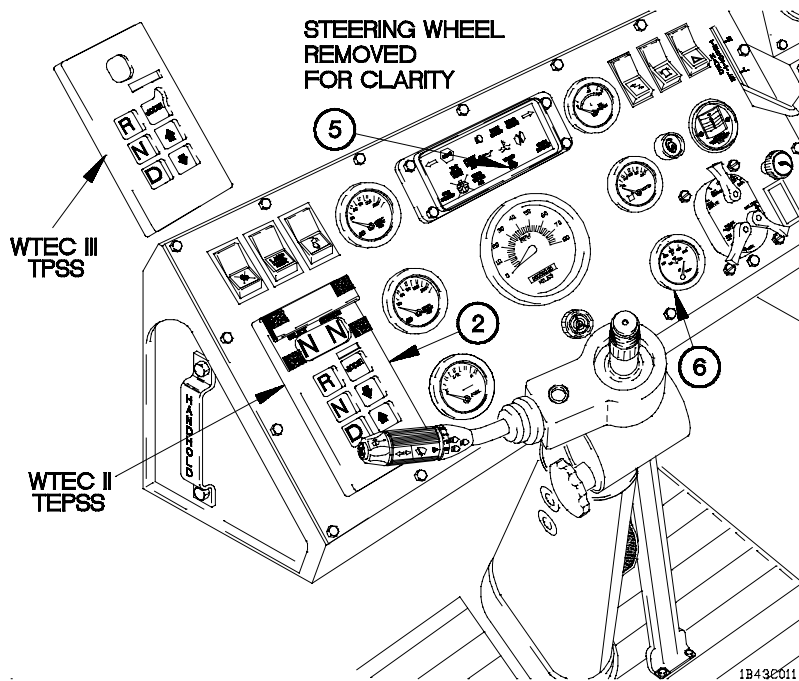
- a. Push N (Neutral) select button (1) on WTEC II TEPSS (2) or WTEC III TPSS (2) while engine is running. Idle engine for approximately two minutes before engine shutdown.

CAUTION

- Do not operate vehicle with radiator fan off switch in the on position. Ensure fan off indicator is not lit. Failure to comply may result in damage to equipment.
 - Placing the radiator fan off switch in the on position will cause the fan not to operate. Failure to comply may result in damage to equipment.
- b. Check that radiator fan off switch (3) is in the off position and the fan off indicator (4) is not illuminated.



2-43. OPERATION IN EXTREME HEAT (CONT)



CAUTION

Never operate engine for more than 30 seconds at full throttle while vehicle is not moving. Transmission oil temperature will become too hot. Failure to comply may result in damage to equipment.

c. If the TRANS OIL TEMP indicator (5) illuminates and WATER TEMP gage (6) reads near 230° F (110° C), transmission oil is overheating:

- (1) Stop vehicle.
- (2) Press the N (Neutral) select button (1) on WTEC II TEPSS (2) or WTEC III TPSS (2).
- (3) Allow engine to operate at approximately 750 rpm for three minutes.
- (4) Continue normal vehicle operation when TRANS OIL TEMP indicator (5) goes out.
- (5) Shut down engine (para 2-21f) and notify Unit Maintenance if TRANS OIL TEMP indicator (5) does not go out.

d. Check cooling system often for the following conditions:

- (1) Low coolant level in radiator overflow tank (para 2-15, item 3).

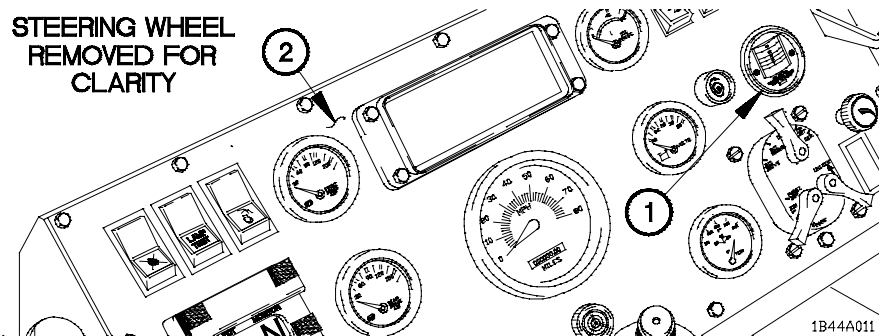
- (2) Cracked or leaking radiator hoses (para 2-15, item 62).
- (3) Radiator fins clogged with dust, leaves, or insects.

NOTE

Batteries do not hold charge well in extreme heat. Batteries will be tagged for use in tropical conditions or extreme heat. Batteries will have a white circle or dot painted on top. Battery electrolyte must be changed to adjust for such conditions. Refer to TM 9-6140-200-14 for procedures.

- e. Check battery electrolyte level daily (para 3-8b).
- f. In hot, damp climates check body and chassis often. Notify Unit Maintenance if any of the following conditions are found:
 - (1) Signs of pitting or paint blistering on metal surfaces.
 - (2) Signs of mildew, mold, or fungus on fabrics and rubber.

2-44. OPERATION IN EXTREME DUST



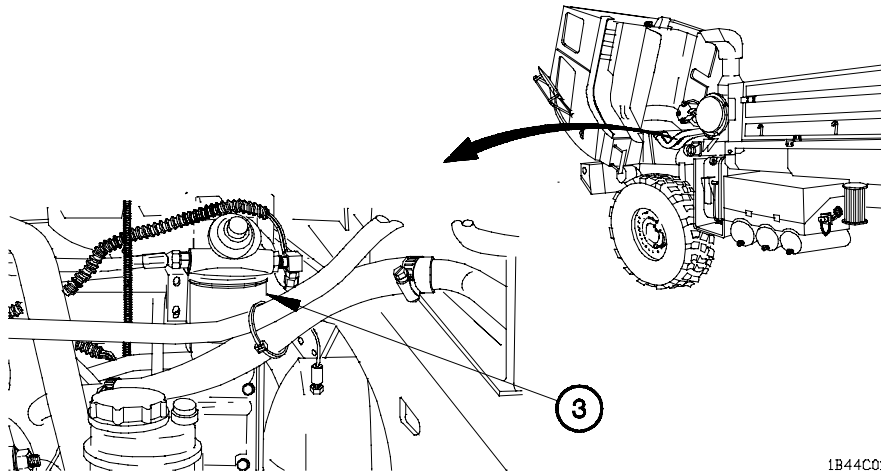
CAUTION

Check AIR FILTER RESTRICTION GAUGE (1) often. Shut down engine immediately (para 2-21f) when yellow diaphragm enters red zone (greater than 25 in.). Failure to comply may result in damage to equipment.

- a. Service air filter (para 3-9). Check other gages and indicator lights on instrument panel (2) to be sure dust does not affect other equipment.

2-44. OPERATION IN EXTREME DUST (CONT)

- b. Allow as much distance as possible between vehicles and operate at low speeds.



1B44C011

- c. Check and drain fuel/water separator (3) at stops (para 2-15, item 32).
- d. Park vehicle so that front of vehicle does not face into wind, when possible.
- e. Cover air intake, radiator, and cab with tarp during extended shutdown.

CAUTION

Keep glass surfaces covered with tarp as much as possible in blowing dust conditions. Failure to comply may result in scratched glass surfaces.

- f. Cover glass surfaces when not needed for operations. Take extra care when cleaning glass to prevent scratching surfaces.

CAUTION

Do not direct high-pressure water stream at glass surfaces, seals, air intake, exhaust outlet, or any other component of vehicle that could be easily damaged by high-pressure water stream. Failure to comply may result in damage to equipment.

- g. Clean dust from wheels, axles, universal joints, steering mechanism, and radiator as soon as possible.

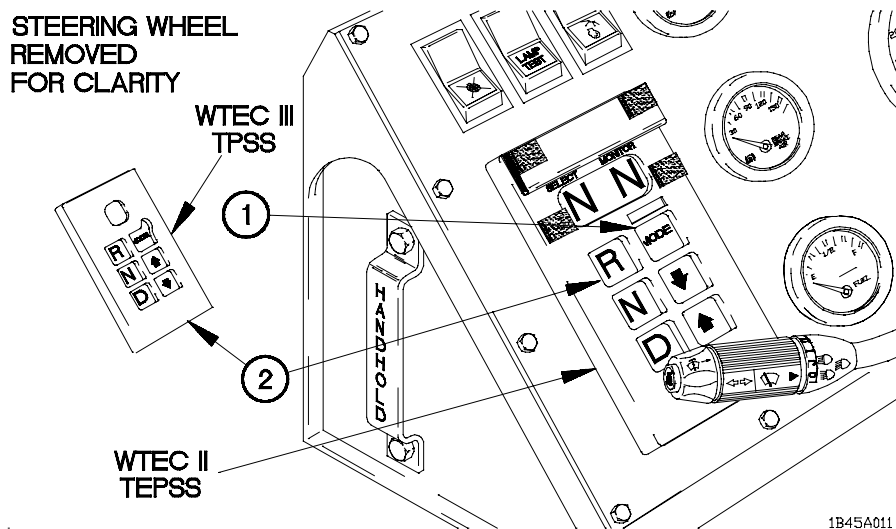
2-45. OPERATION IN FOREST OR ON ROCKY TERRAIN

WARNING

Avoid driving diagonally across a hill. Vehicle could roll over. Failure to comply may result in serious injury or death to personnel or damage to equipment.

CAUTION

- Ensure vehicle has enough clearance before driving over rough terrain. Rough terrain can damage components under vehicle. Failure to comply may result in damage to equipment.
- Ensure vehicle can clear overhanging tree limbs. Failure to comply may result in damage to equipment.
- Ensure that mirrors will not be damaged by rocks or trees by adjusting mirrors to keep rear of vehicle visible. Failure to comply may result in damage to equipment.

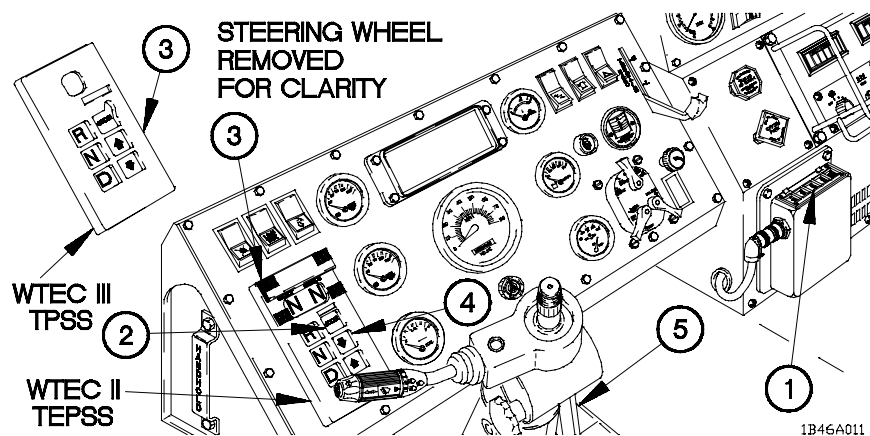


Push MODE select button (1) on WTEC II TEPS (2) or WTEC III TPSS (2) to select desired transmission gear.

2-46. OPERATION IN SAND OR MUD

CAUTION

- Keep glass surfaces covered with a tarp during blowing sand conditions. Use care when cleaning to prevent scratching glass surfaces. Failure to comply may result in scratched glass surfaces.
- Check AIR FILTER RESTRICTION gauge often. If yellow diaphragm enters red zone, shut down engine immediately and service air filter (para 3-9). Failure to comply may result in damage to equipment.



- a. Press CTIS mode to SAND (1).

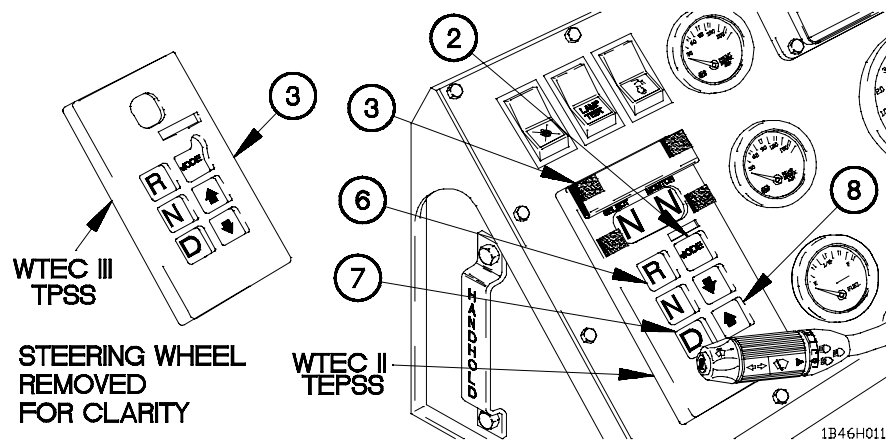
WARNING

Operating in mud causes brake linings to get wet and can impair vehicle braking. Dry brakes by driving vehicle about 500 ft (153 m) while applying service brakes often. If adequate braking is not restored by drying brakes, notify Unit Maintenance. Failure to comply may result in injury to personnel or damage to equipment.

- b. Press MODE select button (2) on WTEC II TEPSS (3) or WTEC III TPSS (3) to select desired transmission gear.
- c. Accelerate slowly so tires do not spin and dig in sand or mud.
- d. Press lower gear range button (4) on WTEC II TEPSS (3) or WTEC III TPSS (3).
- e. Keep accelerator pedal (5) steady after vehicle reaches desired speed.
- f. Turn vehicle slowly when in loose sand or mud.

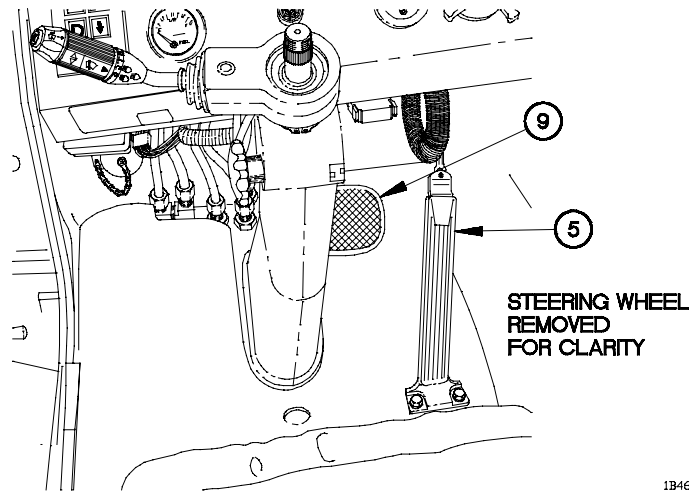
WARNING

- Do not straddle or drive on sides of sand mounds. Loose sand will not support vehicle on steep slopes.
 - Avoid driving diagonally across a hill. Vehicle may roll over. Failure to comply may result in serious injury or death to personnel or damage to equipment.
- g. Steer vehicle straight up and down hills when possible. When driving across a hill is necessary, choose the lowest angle possible, keep vehicle moving, and avoid quick, sharp turns.



- h. To move vehicle forward and turn after vehicle is stopped in loose sand or mud:
- (1) Press MODE (2) on WTEC II TEPSS (3) or WTEC III TPSS (3).
 - (2) Press R (Reverse) select button (6) on WTEC II TEPSS (3) or WTEC III TPSS (3).
 - (3) Move vehicle straight back approximately 20 ft (6 m).
 - (4) Stop vehicle.
 - (5) Press D (Drive) select button (7) on WTEC II TEPSS (3) or WTEC III TPSS (3).
 - (6) Press higher gear select button (8) on WTEC II TEPSS (3) or WTEC III TPSS (3).
 - (7) Move vehicle forward.
 - (8) Gradually turn vehicle as speed is obtained and vehicle is moving forward smoothly.

2-46. OPERATION IN SAND OR MUD (CONT)



1B46J011

j. If vehicle starts to skid:

- (1) Release accelerator pedal (5).
- (2) Steer in direction of skid until vehicle stops skidding.
- (3) Press brake pedal (9) lightly when vehicle is under control.
- (4) Press accelerator pedal (5) slowly and steer vehicle on straight course.

k. To park vehicle:

- (1) Park vehicle so it does not face into the wind whenever possible.
- (2) Clean mud off vehicle as soon as possible (para 3-7).

2-47. OPERATION IN DESERT ENVIRONMENT

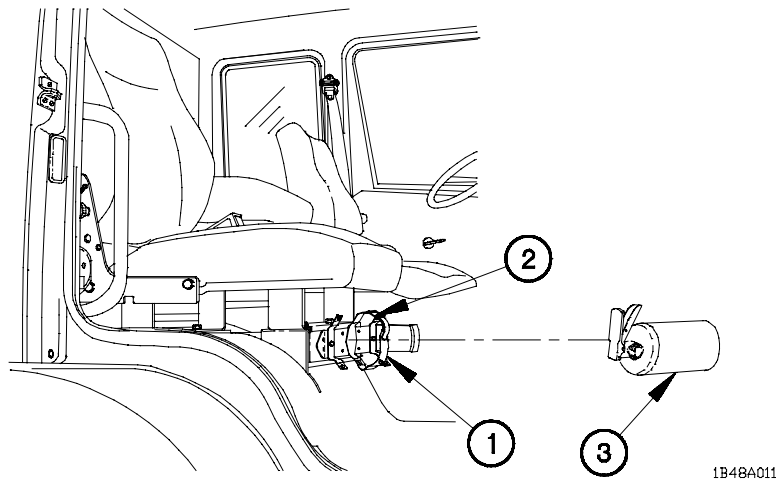
NOTE

FM 90-3 contains detailed instructions for living in desert environment.

- a. Principles of operation in extreme heat, extreme dust, and in sand or mud (para 2-43, 2-44, and 2-46) apply to desert environment operation.
- b. Temperatures can change as much as 70° F (40° C) between day and night. These changes can damage equipment if vehicle is not properly prepared.
- c. Due to expansion and contraction of fluids and air, care should be taken when filling fuel tanks and fluid reservoirs to prevent overflow when temperatures change.

2-48. FIRE EXTINGUISHER OPERATION

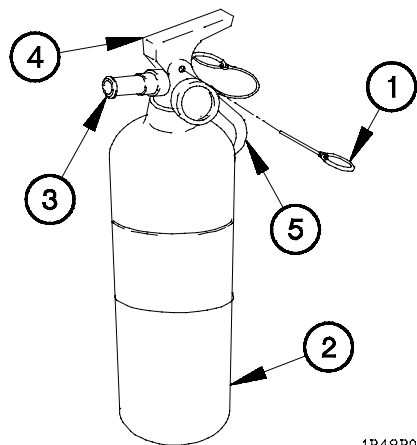
a. Fire Extinguisher Removal.



- (1) Pull up on latch (1) to open clamp (2).
- (2) Remove fire extinguisher (3) from clamp (2).

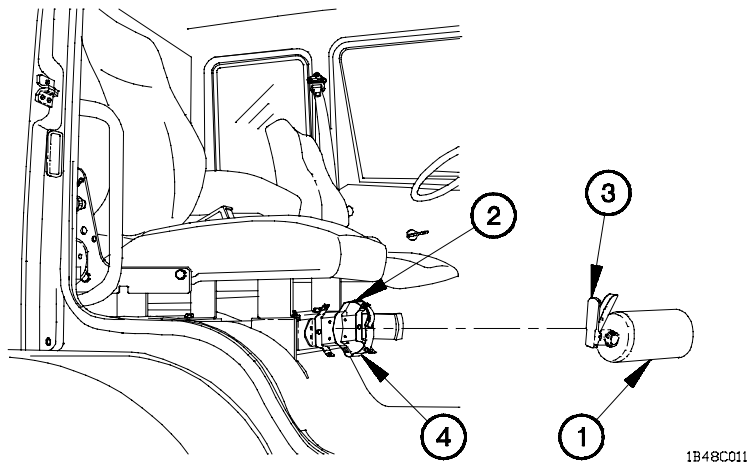
b. Fire Extinguisher Operation.

- (1) Remove safety pin (1) from fire extinguisher (2).
- (2) Holding fire extinguisher (2) upright, point nozzle (3) at base of fire from approximately 8 ft (2.4 m).
- (3) Squeeze together handle (4) and lever (5).
- (4) Spray discharge in a side-to-side motion at base of fire.
- (5) Release handle (4) and lever (5) when fire is out.
- (6) Install safety pin (1) in fire extinguisher (2).
- (7) Notify Unit Maintenance to replace fire extinguisher (2).



2-48. FIRE EXTINGUISHER OPERATION (CONT)

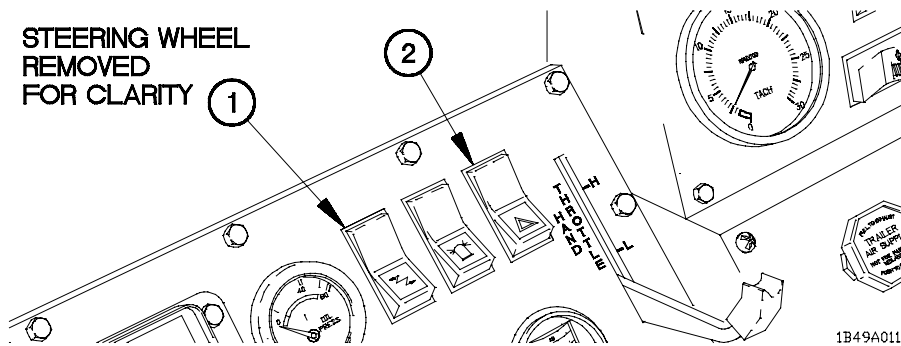
c. Fire Extinguisher Installation.



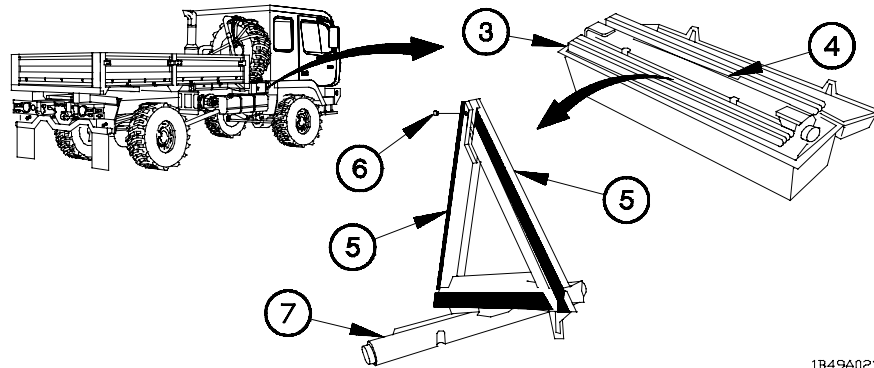
- (1) Install fire extinguisher (1) in clamp (2) with nozzle (3) pointing down.
- (2) Push down on latch (4) to secure fire extinguisher (1) in clamp (2).

2-49. HIGHWAY EMERGENCY MARKER KIT SETUP

a. Preparing markers for use:



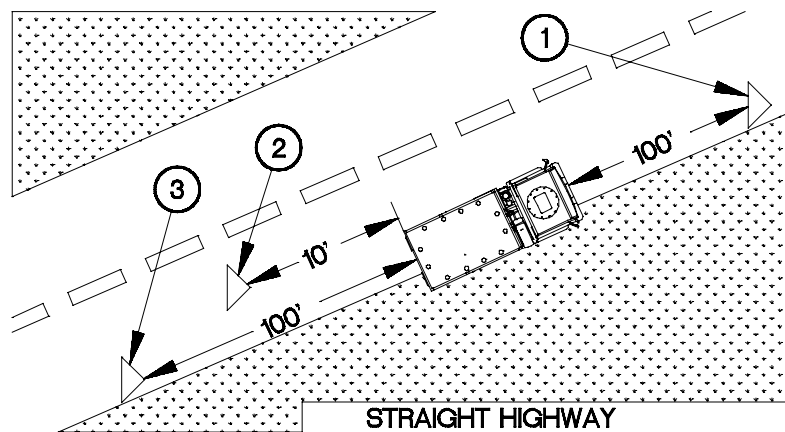
- (1) Position master power switch (1) to on.
- (2) Position hazard lights switch (2) to on.



1B49A021

- (3) Remove emergency marker kit (3) from TOOL KIT.
- (4) Remove three markers (4) from emergency marker kit (3).
- (5) Attach two ends of marker arms (5) with pin (6).
- (6) Rotate marker (5) approximately 1/4 turn on base (7).
- (7) Perform steps (4) through (6) for second and third markers.

b. Placing markers on undivided, straight highway:

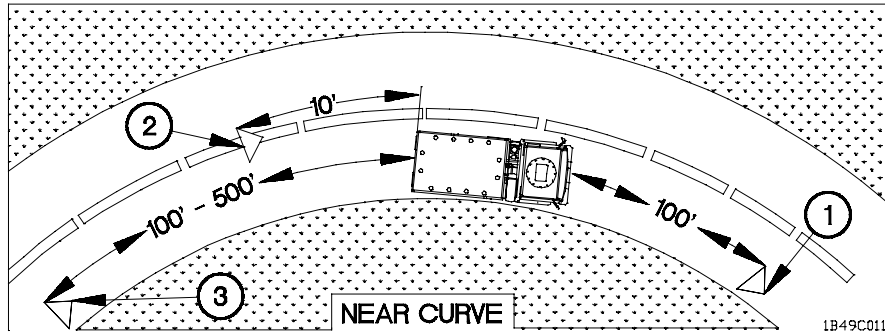


1B49B011

- (1) Place one marker (1) approximately 100 ft (30 m) in front of vehicle with marker facing approaching traffic.
- (2) Place second marker (2) approximately 10 ft (3 m) behind vehicle and about 5 ft (1.5 m) out from side of vehicle with marker facing approaching traffic.
- (3) Place third marker (3) approximately 100 ft (30 m) behind vehicle with marker facing approaching traffic.

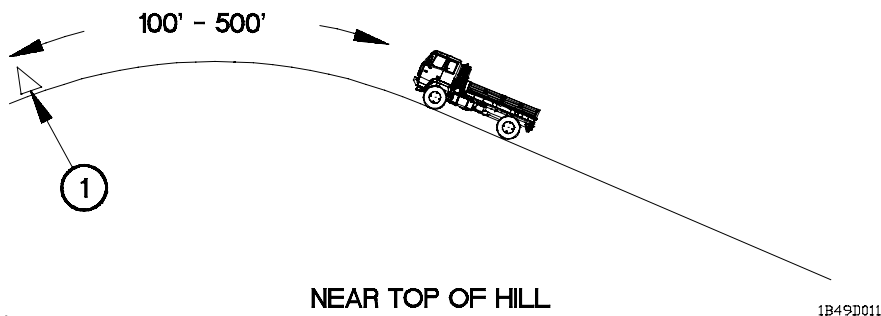
2-49. HIGHWAY EMERGENCY MARKER KIT SETUP (CONT)

c. Placing markers on undivided, curved highway:



- (1) Place one marker (1) approximately 100 ft (30 m) in front of vehicle with marker facing approaching traffic.
- (2) Place second marker (2) approximately 10 ft (3 m) behind vehicle and about 5 ft (1.5 m) out from side of vehicle with marker facing approaching traffic.
- (3) Place third marker (3) approximately 100 to 500 ft (30 to 150 m) behind vehicle with marker facing approaching traffic and visible before traffic reaches curve.

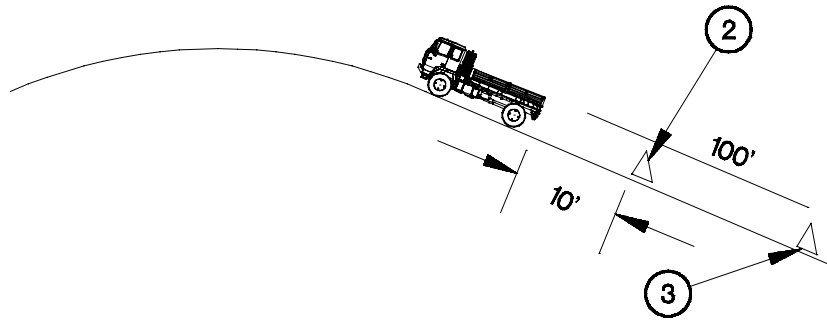
d. Placing markers on undivided highway with hills:



WARNING

Vehicle must be secure. Chock wheels when stopped on incline. Vehicle may roll downhill. Failure to comply may result in serious injury or death to personnel or damage to equipment.

- (1) Place one marker (1) approximately 100 to 500 ft (30 to 150 m) in front of vehicle with marker facing approaching traffic and visible before traffic reaches top of hill.

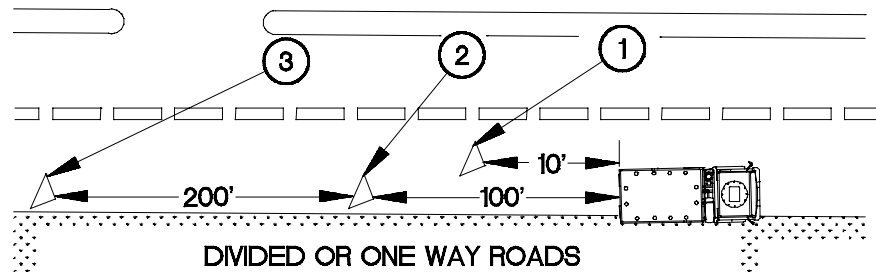


NEAR TOP OF HILL

1B49D021

- (2) Place second marker (2) approximately 10 ft (3 m) behind vehicle and about 5 ft (1.5 m) out from side of vehicle with marker facing approaching traffic.
- (3) Place third marker (3) approximately 100 ft (30 m) behind vehicle with marker facing approaching traffic.

e. Placing markers on divided highway or one way road:



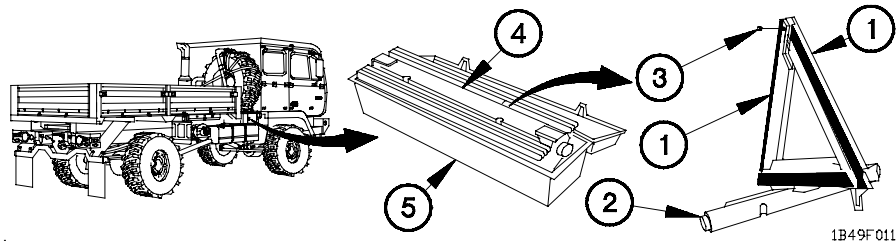
DIVIDED OR ONE WAY ROADS

1B49E011

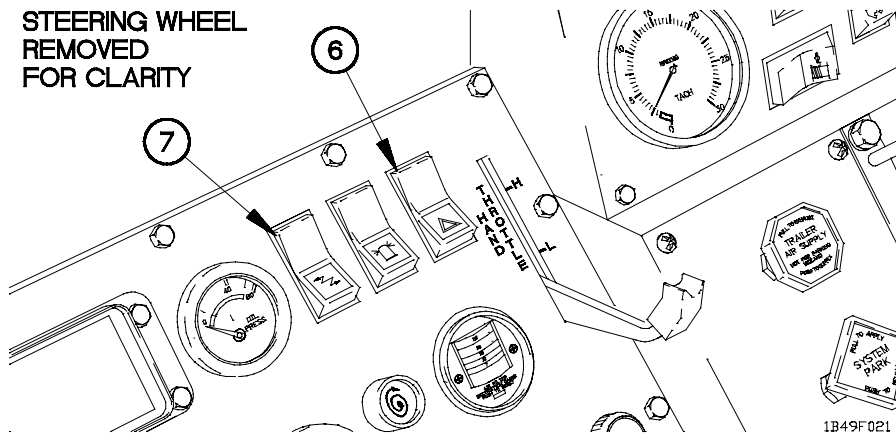
- (1) Place one marker (1) approximately 10 ft (3 m) behind vehicle and about 5 ft (1.5 m) out from side of vehicle with marker facing approaching traffic.
- (2) Place second marker (2) approximately 100 ft (30 m) behind vehicle with marker facing approaching traffic.
- (3) Place third marker (3) approximately 200 ft (60 m) behind second marker with marker facing approaching traffic.

2-49. HIGHWAY EMERGENCY MARKER KIT SETUP (CONT)

g. Stowing markers.



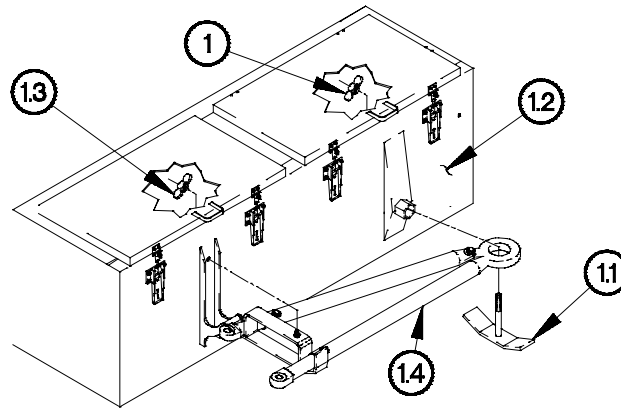
- (1) Rotate marker arms (1) approximately 1/4 turn on base (2).
- (2) Separate marker arms (1) by removing pin (3).
- (3) Fold marker arms (1) down to base (2).
- (4) Perform steps (1) through (3) for second and third markers.
- (5) Stow three markers (4) in emergency marker kit (5).
- (6) Stow emergency marker kit (5) in TOOL KIT.



- (7) Position hazard lights switch (6) to off.
- (8) Position master power switch (7) to off.

2-50. TOWBAR CONNECTION/DISCONNECTION

a. Towbar Connection.



1B50A01B

- (1) Remove nut (1) and bracket (1.1) from tool box (1.2).

WARNING

Towbar weighs approximately 150 lbs (68 kgs). Attach a suitable lifting device prior to removal. Failure to comply may result in injury to personnel or damage to equipment.

NOTE

Step (1.1) requires the aid of two assistants.

- (1.1) Remove nut (1.3) and towbar (1.4) from tool box (1.2).

WARNING

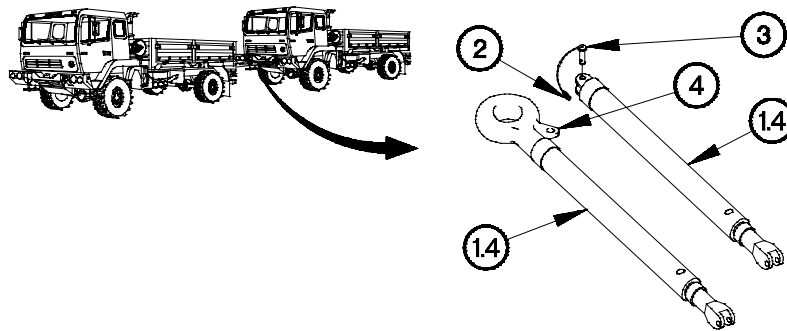
Towing vehicle and disabled vehicle must have parking brakes applied before connecting/disconnecting towbar. Vehicle may roll into each other. Failure to comply may result in serious injury or death to personnel.

NOTE

Step (1.2) requires the aid of an assistant.

- (1.2) Position rear of towing vehicle near front of disabled vehicle.

2-50. TOWBAR CONNECTION/DISCONNECTION (CONT)

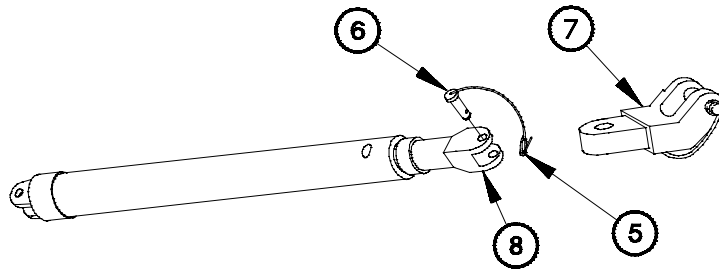


1B50A02B

NOTE

Step (2) requires the aid of two assistants.

- (2) Position towbar (1.4) between vehicles.
- (3) Remove lynch pin (2) from pin (3).
- (4) Remove pin (3) from towbar (1.4).
- (5) Separate towbar (1.4) at pivot point (4).

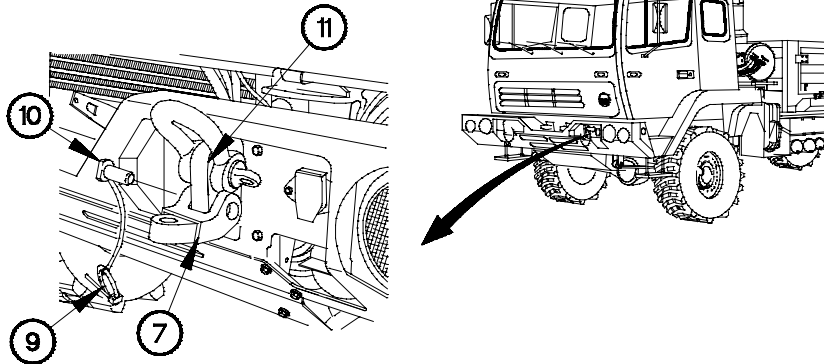


1B50A03B

NOTE

Left and right side towbar adapters are removed from towbar clevises the same way. Left side shown.

- (6) Remove two lynch pins (5), pins (6), and towbar adapters (7) from towbar clevises (8).



1B50A04B

NOTE

Left and right side towbar adapters are installed on tow eyes the same way. Left side shown.

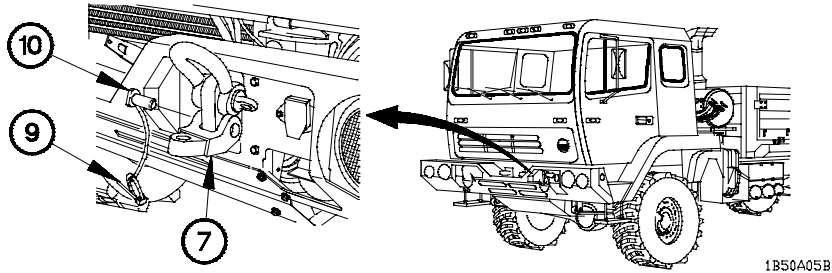
- (7) Remove two lynch pins (9) and pins (10) from towbar adapters (7).

NOTE

It may be necessary to remove shackles on some vehicles.

- (8) Install two towbar adapters (7) on eyes (11) of disabled vehicle.

2-50. TOWBAR CONNECTION/DISCONNECTION (CONT)

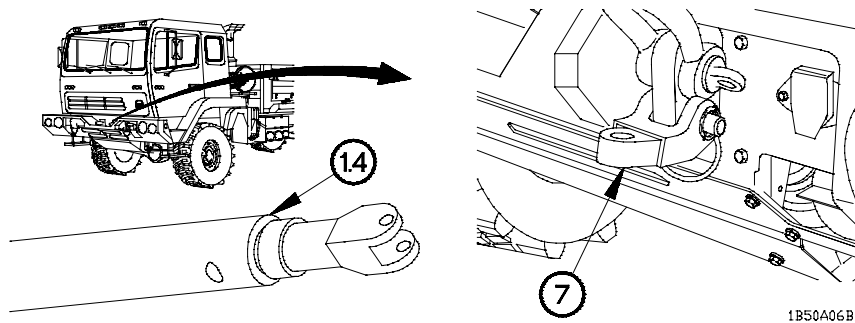


CAUTION

Ensure pins are installed with lynch pin holes down. Failure to comply may result in damage to equipment.

(9) Position two pins (10) in towbar adapters (7).

(10) Install two lynch pins (9) in pins (10).



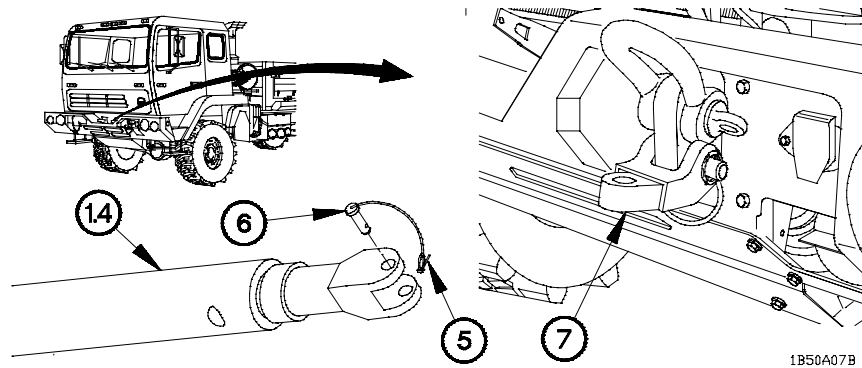
WARNING

Towbar weighs approximately 150 lbs (68 kgs). Attach a suitable lifting device prior to installation. Failure to comply may result in injury to personnel or damage to equipment.

NOTE

- Left and right sides of towbar are installed on towbar adapters the same way. Left side shown.
- Step (11) requires the aid of two assistants.

(11) Position towbar (1.4) on two towbar adapters (7).

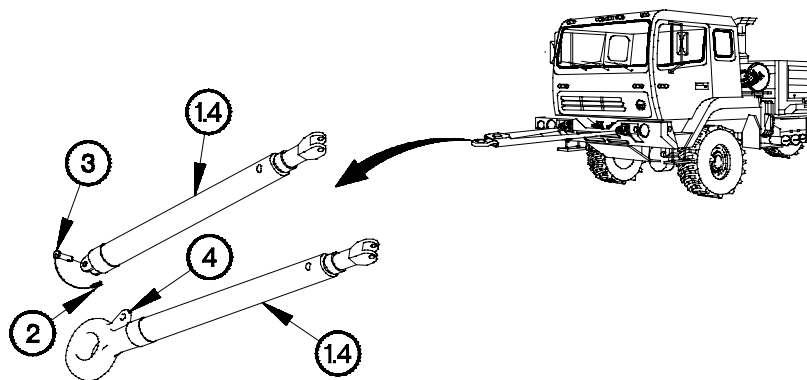


CAUTION

Ensure pin is installed with lynch pin hole down. Failure to comply may result in damage to equipment.

(12) Install two pins (6) in towbar (1.4) and towbar adapters (7).

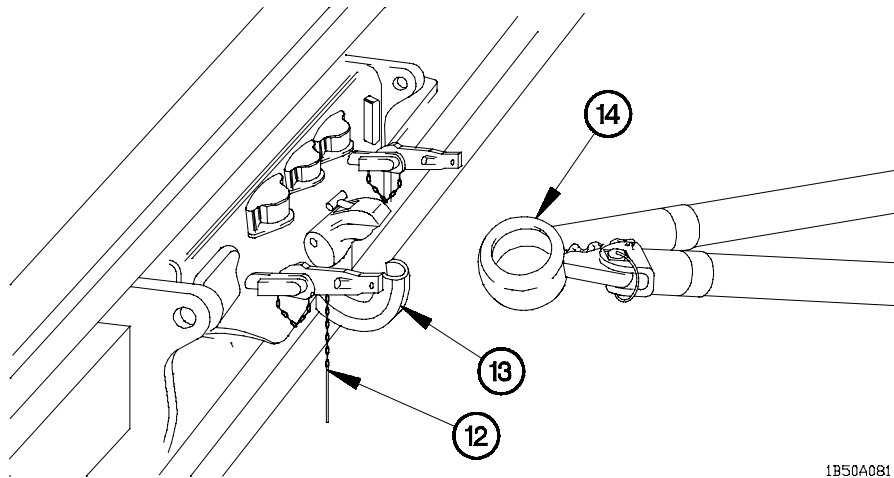
(13) Install two lynch pins (5) in pins (6).



(14) Align left and right sides of towbar (1.4) at pivot point (4).

(15) Install pin (3) in towbar (1.4).

(16) Install lynch pin (2) in pin (3).



1B50A081

(17) Remove cotter pin (12) from pintle hook (13).

(18) Open pintle hook (13).

WARNING

- **Ground guide is required to guide vehicle backing up. Failure to comply may result in injury to personnel or damage to equipment.**
- **Do not place hands near pintle hook when connecting/disconnecting towbar with pintle hook. Failure to comply may result in injury to personnel.**

NOTE

Steps (19) and (20) require the aid of an assistant.

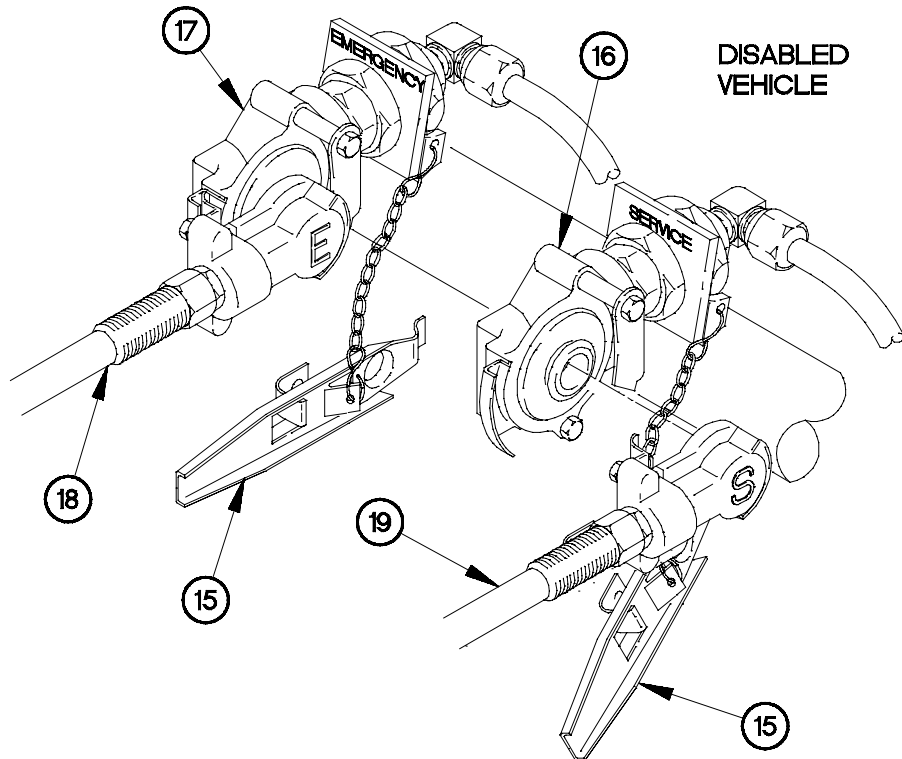
(19) Slowly back up towing vehicle until towbar eye (14) is aligned with pintle hook (13).

(20) Connect towbar eye (14) to pintle hook (13).

(21) Close pintle hook (13).

(22) Install cotter pin (12) in pintle hook (13).

2-50. TOWBAR CONNECTION/DISCONNECTION (CONT)



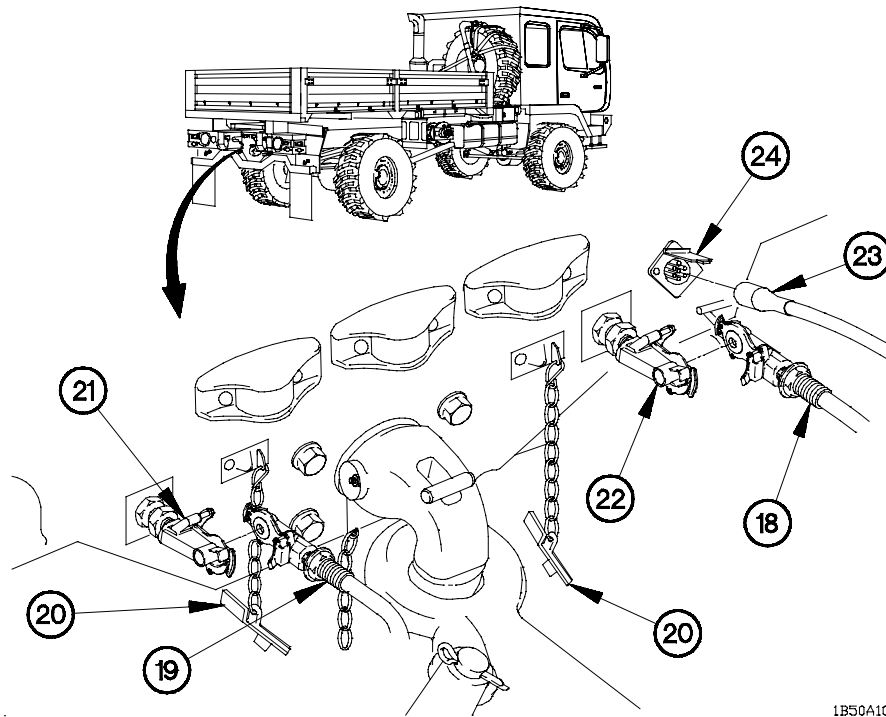
1B50A091

- (23) Release parking brakes of disabled vehicle (refer to disabled vehicle Operator's manual).
- (24) Remove two dummy couplings (15) from service gladhand (16) and emergency gladhand (17) on front of disabled vehicle.

WARNING

Listen for air leaks coming from the connections at the service and emergency gladhands. Failure to comply may result in serious injury or death to personnel or damage to equipment.

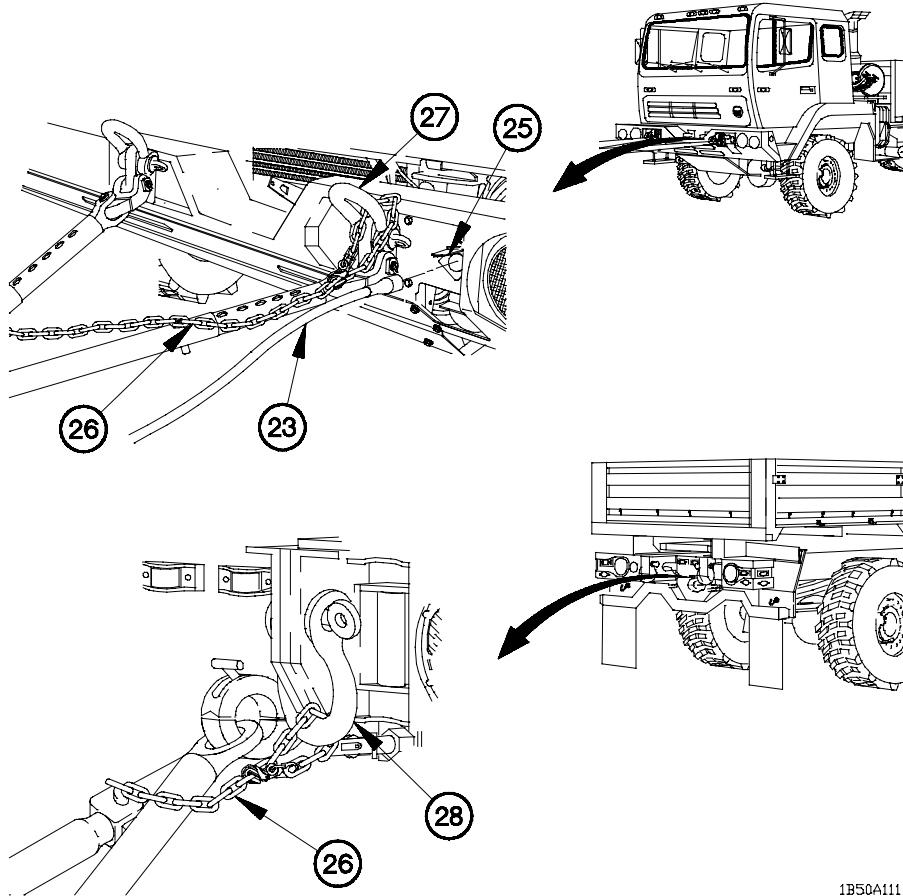
- (25) Connect intervehicular air hose (18) to emergency gladhand (17) of disabled vehicle.
- (26) Connect intervehicular air hose (19) to service gladhand (16) of disabled vehicle.



1B50A101

- (27) Remove two dummy couplings (20) from service gladhand (21) and emergency gladhand (22) of towing vehicle.
- (28) Connect intervehicular air hose (18) to emergency gladhand (22).
- (29) Connect intervehicular air hose (19) to service gladhand (21).
- (30) Connect intervehicular cable (23) to rear receptacle (24) of towing vehicle.

2-50. TOWBAR CONNECTION/DISCONNECTION (CONT)



1B50A111

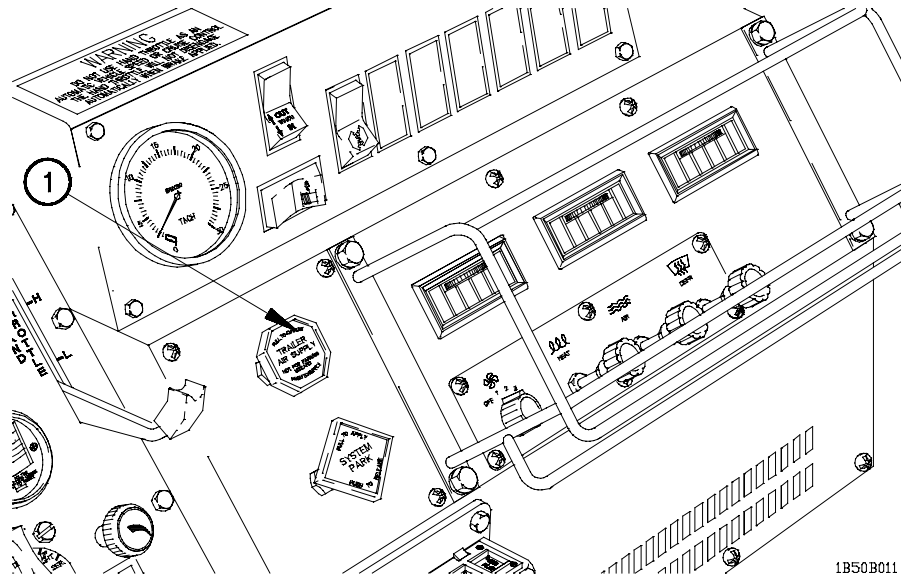
(31) Connect intervehicular cable (23) to front receptacle (25) of disabled vehicle.

NOTE

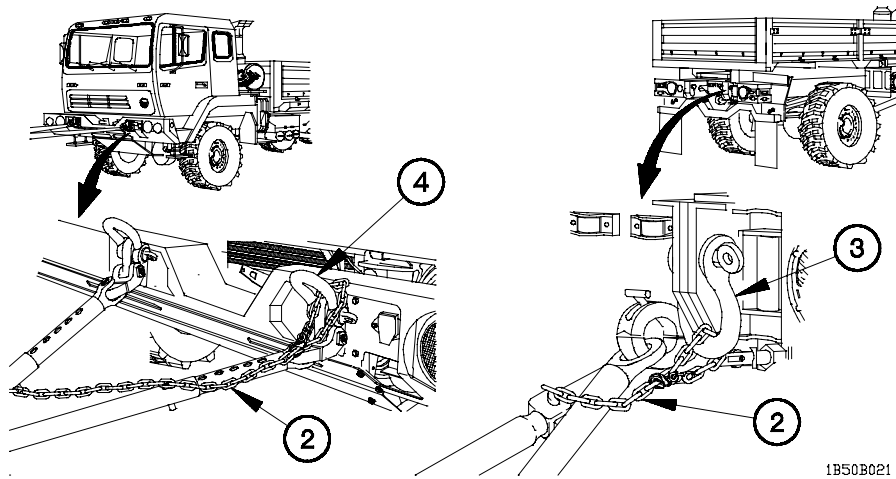
Left and right side chains are installed the same way. Right side shown.

(32) Attach two chains (26) to shackles (27) on disabled vehicle and to shackles (28) on towing vehicle.

b. Towbar Disconnection.



- (1) Pull out TRAILER AIR SUPPLY control (1) on towing vehicle.

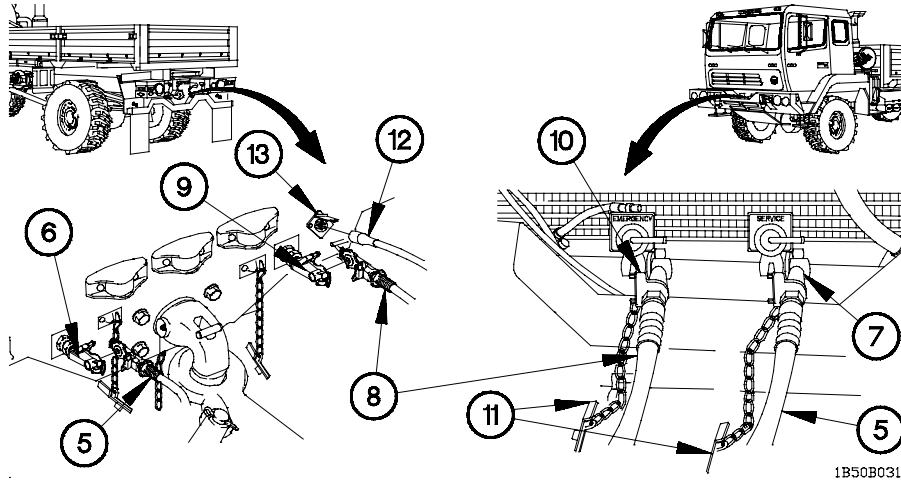


NOTE

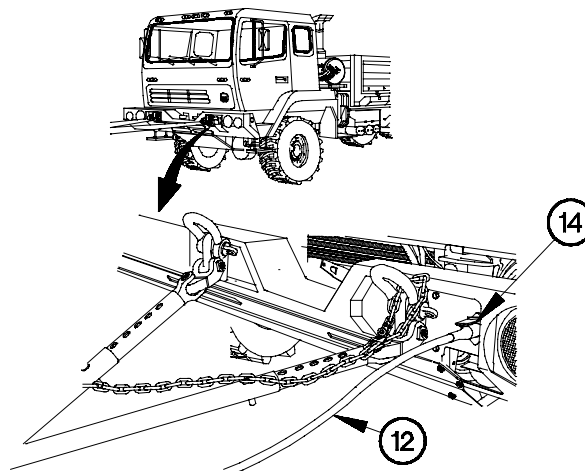
Left and right side chains are removed the same way. Right side shown.

- (2) Disconnect two chains (2) from shackles (3) of towing vehicle and from shackles (4) on disabled vehicle.

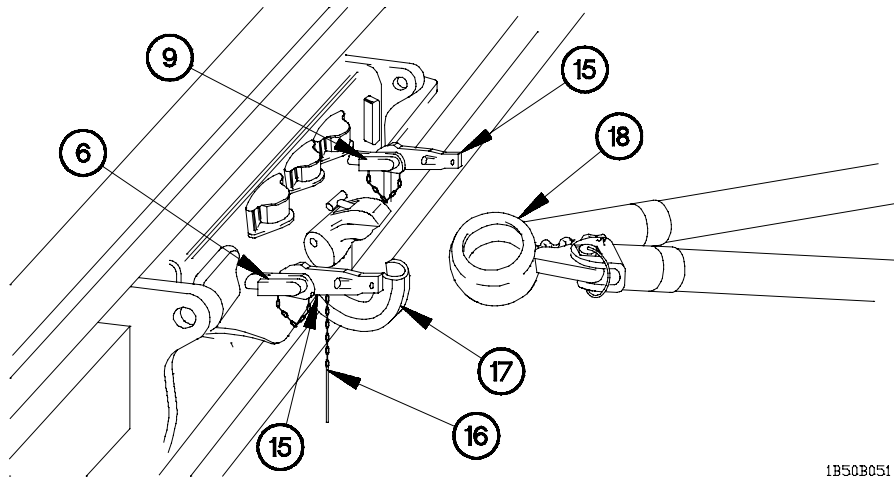
2-50. TOWBAR CONNECTION/DISCONNECTION (CONT)



- (3) Disconnect intervehicular air hose (5) from service gladhand (6) of towing vehicle and service gladhand (7) on disabled vehicle.
- (4) Disconnect intervehicular air hose (8) from emergency gladhand (9) of towing vehicle and emergency gladhand (10) on disabled vehicle.
- (5) Install dummy couplings (11) on gladhands (7 and 10) of disabled vehicle.
- (6) Disconnect intervehicular cable (12) from rear receptacle (13) on towing vehicle.



- (7) Disconnect intervehicular cable (12) from front receptacle (14) on disabled vehicle.



1B50B051

- (8) Install dummy couplings (15) on gladhands (6 and 9) of towing vehicle.
- (9) Remove cotter pin (16) from pintle hook (17).
- (10) Open pintle hook (17).

WARNING

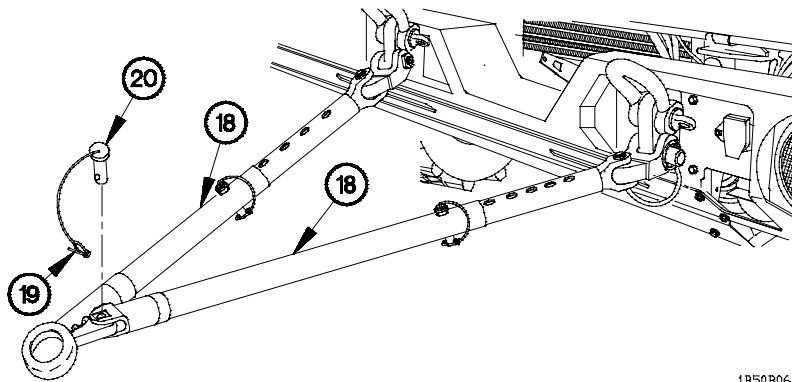
Do not place hands near pintle hook when connecting/disconnecting towbar with pintle hook. Failure to comply may result in injury to personnel.

NOTE

Steps (11) and (12) require the aid of an assistant.

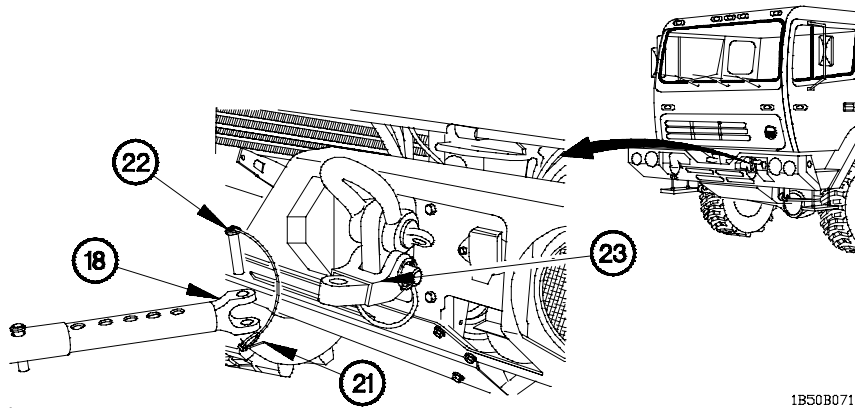
- (11) Remove towbar (18) from pintle hook (17).
- (12) Drive towing vehicle forward. When towing vehicle is clear, lower towbar (18) to ground.
- (13) Close pintle hook (17).
- (14) Install cotter pin (16) in pintle hook (17).

2-50. TOWBAR CONNECTION/DISCONNECTION (CONT)



(15) Remove lynch pin (19) and pin (20) from towbar (18).

(16) Separate left and right sides of towbar (18).



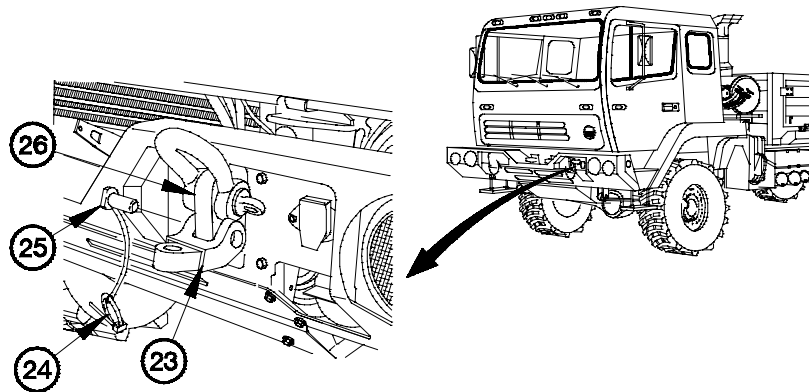
WARNING

Towbar weighs approximately 150 lbs (68 kgs). Attach a suitable lifting device prior to removal. Failure to comply may result in injury to personnel or damage to equipment.

NOTE

- Left and right sides of towbar are removed the same way. Left side shown.
- Step (17) requires the aid of two assistants.

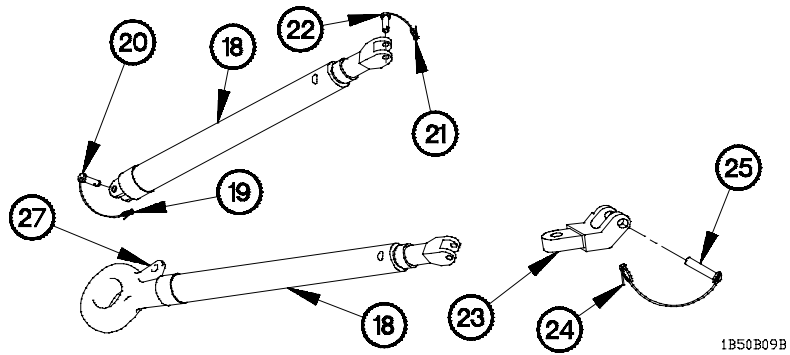
(17) Remove two lynch pins (21), pins (22), and towbar (18) from two towbar adapters (23).



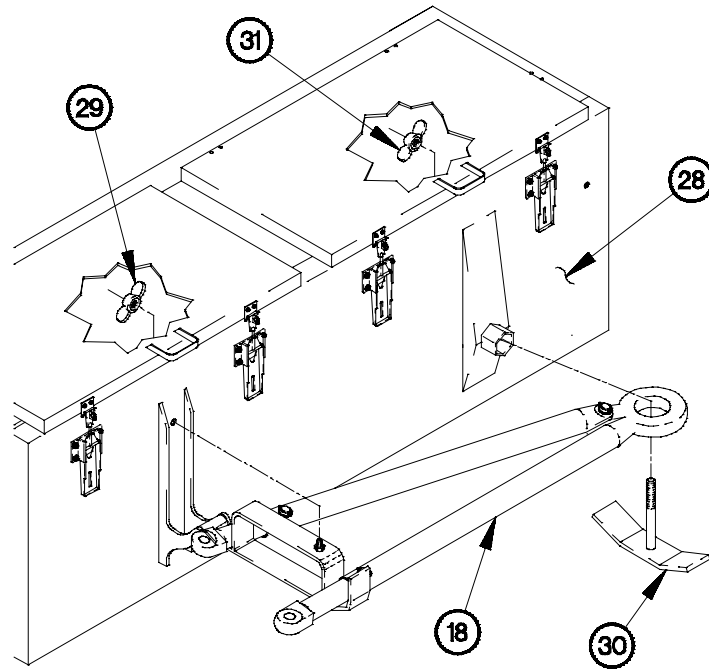
NOTE

Left and right side towbar adapters are removed the same way. Left side shown.

- (18) Remove two lynch pins (24), pins (25), and towbar adapters (23) from tow eyes (26).



- (19) Align left and right sides of towbar (18) at pivot point (27).
- (20) Install two pins (25) and lynch pins (24) in towbar adapters (23).
- (21) Install two towbar adapters (23) on towbar (18) with two pins (22) and lynch pins (21).
- (22) Install pin (20) and lynch pin (19) in towbar (18).



1B50B10B

WARNING

Towbar weighs approximately 150 lbs (68 kgs). Attach a suitable lifting device prior to installation. Failure to comply may result in injury to personnel or damage to equipment.

NOTE

Steps (23) and (24) require the aid of two assistants.

- (23) Install towbar (18) on tool box (28) with nut (29).
- (24) Install bracket (30) on tool box (28) with nut (31).

2-51. TOWING DISABLED VEHICLE

a. Towbar Connection.

WARNING

- **DO NOT flat tow a fully loaded MTV and trailer combination. The MTV Wrecker towbar can be damaged if weight capacity is exceeded. Failure to comply may result in serious injury or death to personnel or damage to equipment.**
- **When towing a vehicle with nonfunctional brakes, use extreme caution and reduce/adjust speed accordingly. Failure to comply may result in serious injury or death to personnel or damage to equipment.**

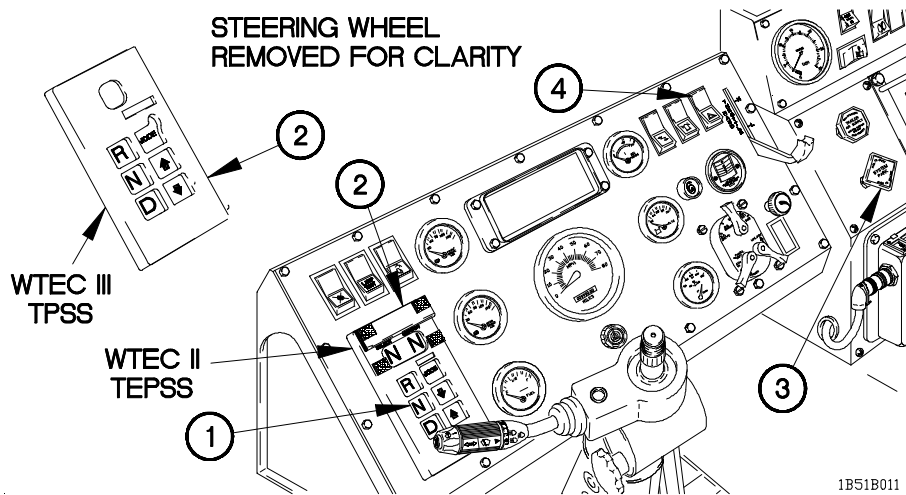
CAUTION

- Flat towing is the recommended means of towing. Lift and tow should only be performed in situations that provide no other means to move the disabled vehicle. Lift and tow may damage frame. Failure to comply may result in damage to equipment.
 - Both drive shafts must be removed when flat towing an M1078 series vehicle over 100 miles (161km) or if towing speed is over 35 MPH. Failure to comply may result in damage to equipment.
- (1) Connect towbar between towing vehicle and disabled vehicle (para 2-50).
 - (2) Cage rear brakes on disabled vehicle (para 3-14).

NOTE

If disabled vehicle is a M1078 series vehicle, proceed to subpara **b**. If disabled vehicle is another series vehicle, refer to Operator's manual for that vehicle.

b.Preparation of Disabled Vehicle (M1078 Series).



CAUTION

- Both drive shafts must be removed when flat towing an M1078 series vehicle over 100 miles (161km) or if towing speed is over 35 MPH. Failure to comply may result in damage to equipment.
- Front drive shaft must be removed prior to performing a rear connection lift and tow. Failure to comply may result in damage to equipment.
- Rear drive shaft must be removed prior to performing a front connection lift and tow. Failure to comply may result in damage to equipment.

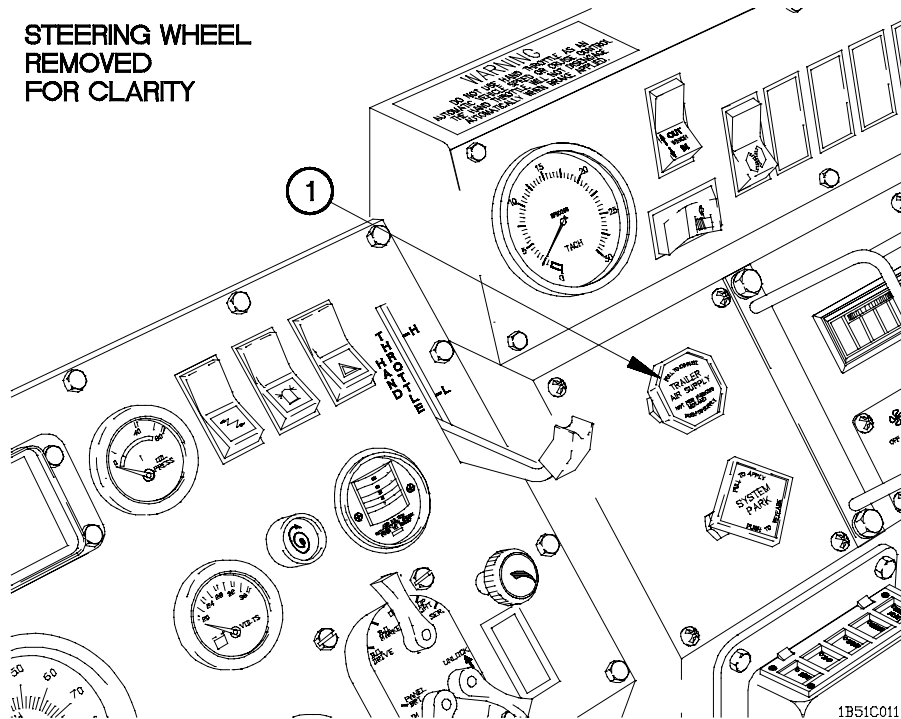
NOTE

Disabled vehicles must be prepared and moved in accordance with FM 20-22 and FM 21-305.

- (1) Notify Unit Maintenance to remove drive shaft(s) as required.
- (1.1) Press N (Neutral) button (1) on WTEC II TEPSS (2) or WTEC III TPSS (2).
- (2) Push in SYSTEM PARK control (3).
- (3) Position hazard lights switch (4) to on.

c. Preparation of Towing Vehicle.

STEERING WHEEL
REMOVED
FOR CLARITY



- (1) Start engine (para 2-21a or b).
- (2) Push in TRAILER AIR SUPPLY control (1).

WARNING

Personnel must not occupy towed vehicle during towing operation. Vehicle may become disconnected while being towed. Failure to comply may result in serious injury or death to personnel.

CAUTION

Maximum speed for flat tow of M1078 series vehicles is 30 mph (48 km/h). Failure to comply may result in damage to vehicle.

- (3) Transport disabled vehicle.

2-52. DELETED

a. Deleted.

2-53. DELETED

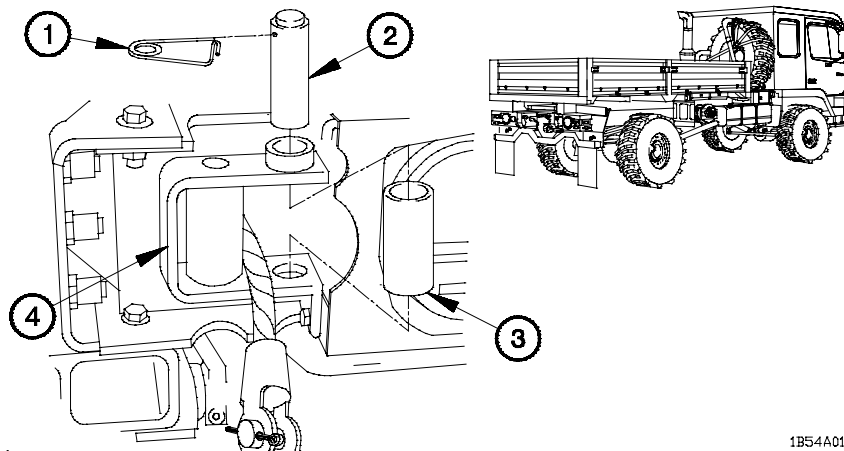
a. Deleted.

(2) Deleted.

(3) Deleted.

2-54. 11K SELF-RECOVERY WINCH (SRW) OPERATION

a. Spooling Cable to Front of Vehicle.



1B54A011

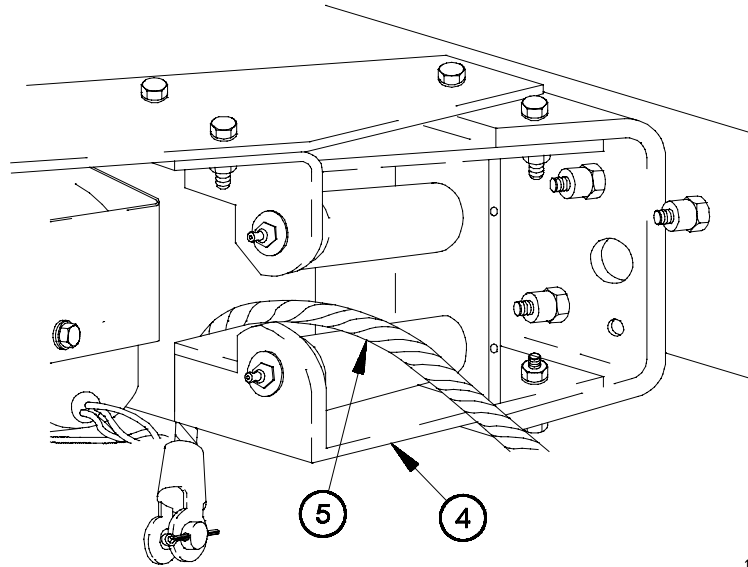
WARNING

Wear heavy leather-palmed work gloves when handling cable. Cables can become frayed or contain broken wires. Never let moving cable slide through hands, even when wearing gloves. Failure to comply may result in injury or to personnel.

(1) Shut down engine (para 2-21f).

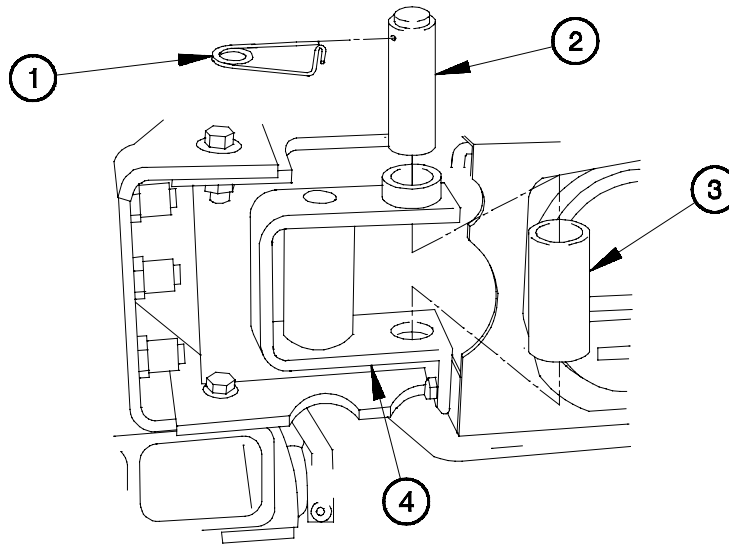
(2) Remove retaining pin (1), pin (2), and roller (3) from rear roller support (4).

2-54. 11K SELF-RECOVERY WINCH (SRW) OPERATION (CONT)



1B54A021

(3) Remove cable (5) from rear roller support (4).

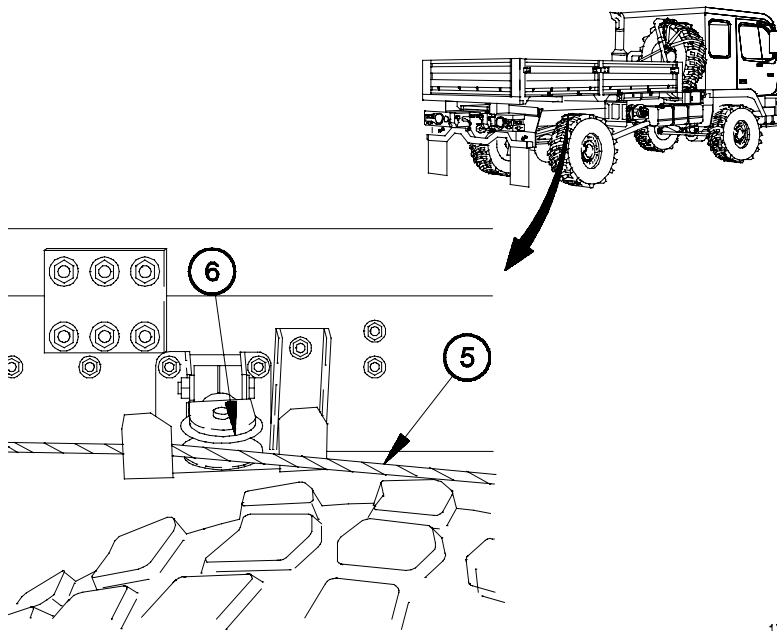


1B54A031

NOTE

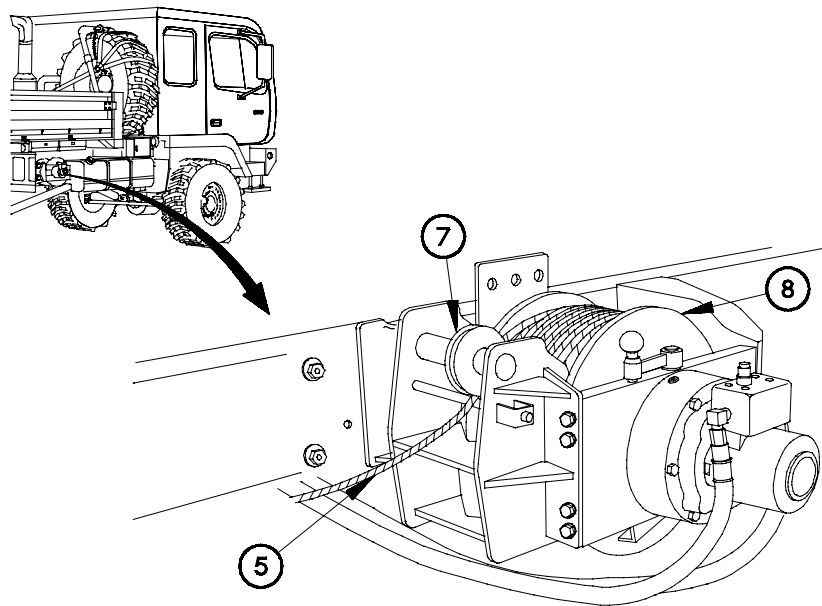
Install retaining pin so that clasp end is toward curbside of vehicle.

(4) Install roller (3) in rear roller support (4) with pin (2) and retaining pin (1).



1B54A041

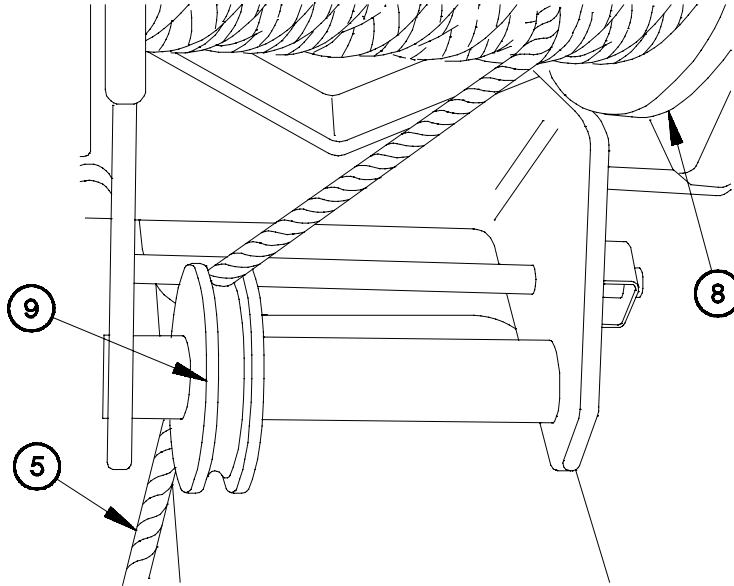
(5) Remove cable (5) from rear cable pulley (6).



1B54A051

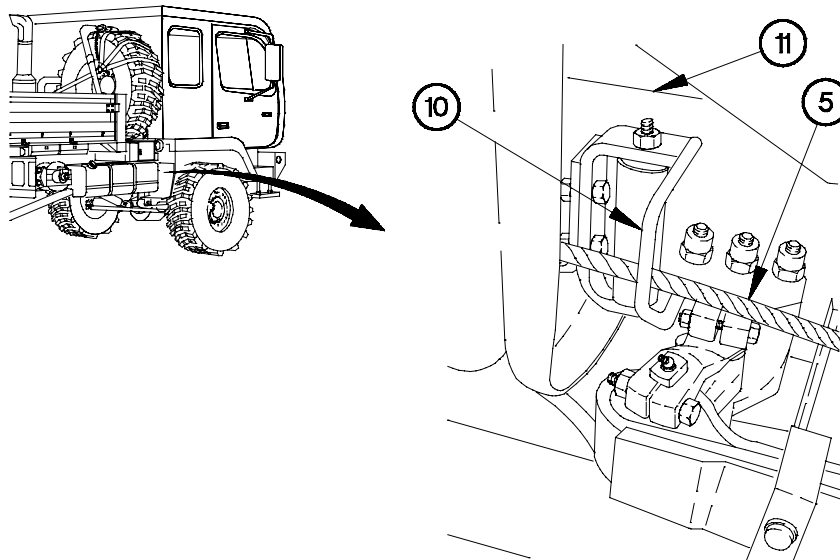
(6) Remove cable (5) from rear cable guide (7) on 11K SRW (8).

2-54. 11K SELF-RECOVERY WINCH (SRW) OPERATION (CONT)



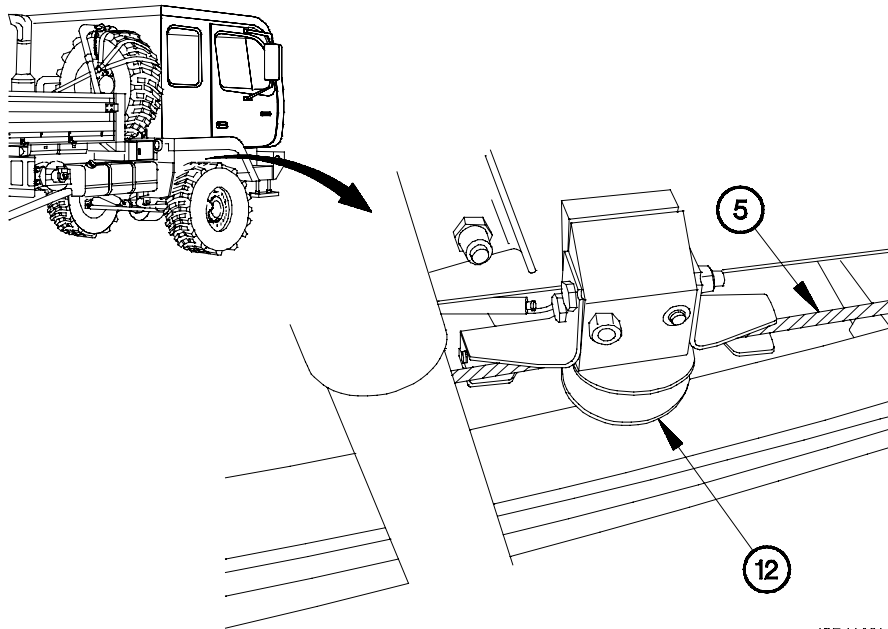
1B54A061

- (7) Position cable (5) toward front of vehicle.
- (8) Install cable (5) through front cable guide (9) on 11K SRW (8).



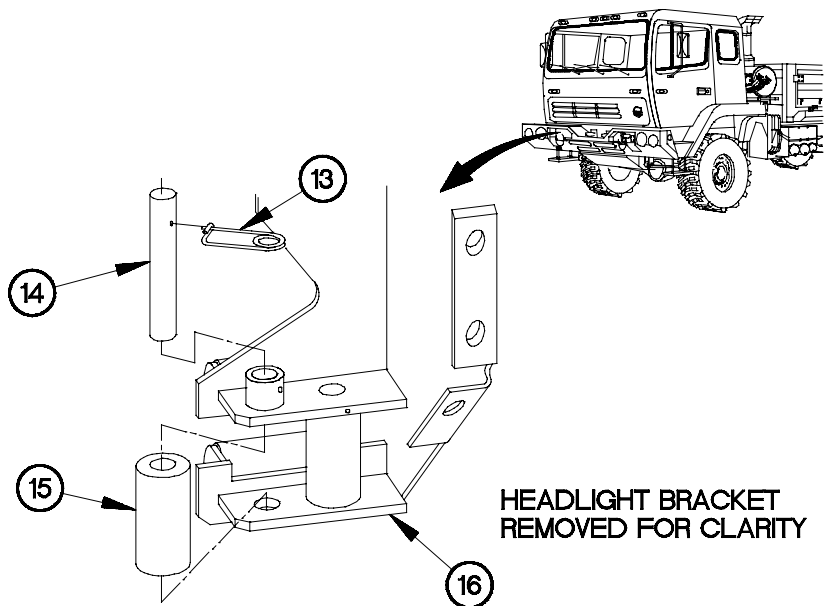
1B54A071

- (9) Install cable (5) through cable guide (10) behind fuel tank (11).



1B54A081

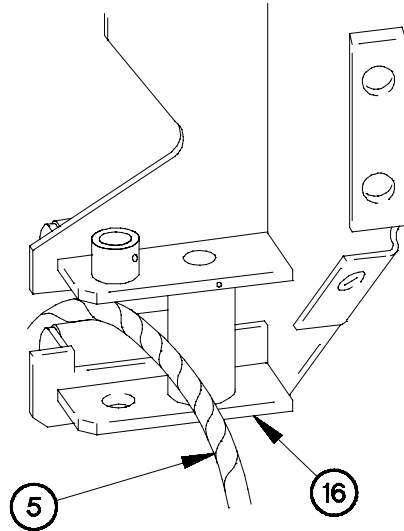
(10) Install cable (5) through front cable pulley (12).



1B54A091

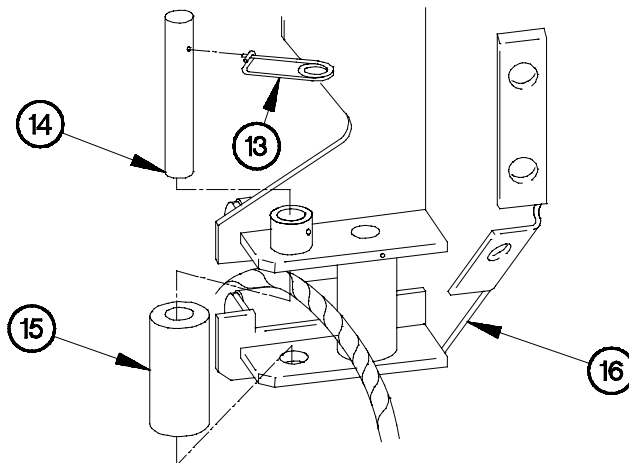
(11) Remove retaining pin (13), pin (14), and roller (15) from front roller support (16).

2-54. 11K SELF-RECOVERY WINCH (SRW) OPERATION (CONT)



1B54A101

(12) Install cable (5) through front roller support (16).



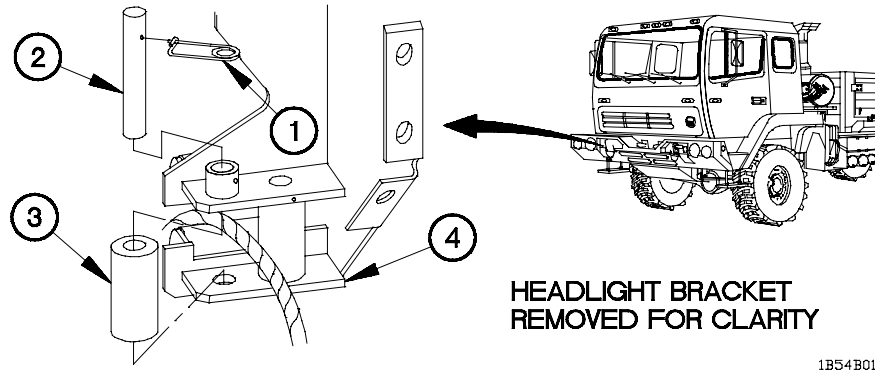
1B54A111

NOTE

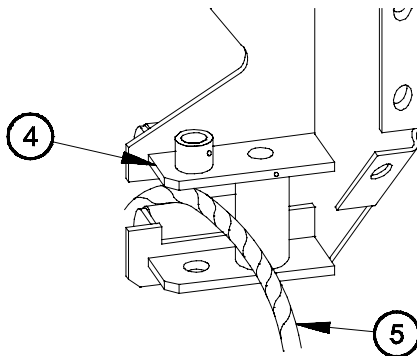
Install retaining pin so that clasp end is toward curbside of vehicle.

(13) Install roller (15) on front roller support (16) with pin (14) and retaining pin (13).

b. Spooling Cable to Rear of Vehicle.



- (1) Shut down engine (para 2-21f).
- (2) Remove retaining pin (1), pin (2), and roller (3) from front roller support (4).

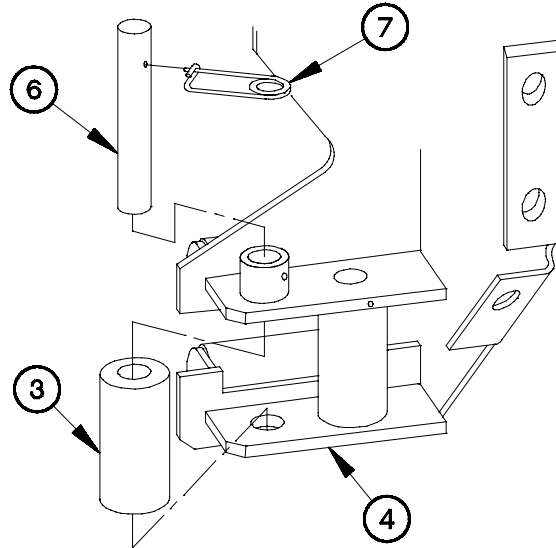


WARNING

Wear heavy leather-palmed work gloves when handling cable. Cables can become frayed or contain broken wires. Never let moving cable slide through hands, even when wearing gloves. Failure to comply may result in injury to personnel.

- (3) Remove cable (5) from front roller support (4).

2-54. 11K SELF-RECOVERY WINCH (SRW) OPERATION (CONT)

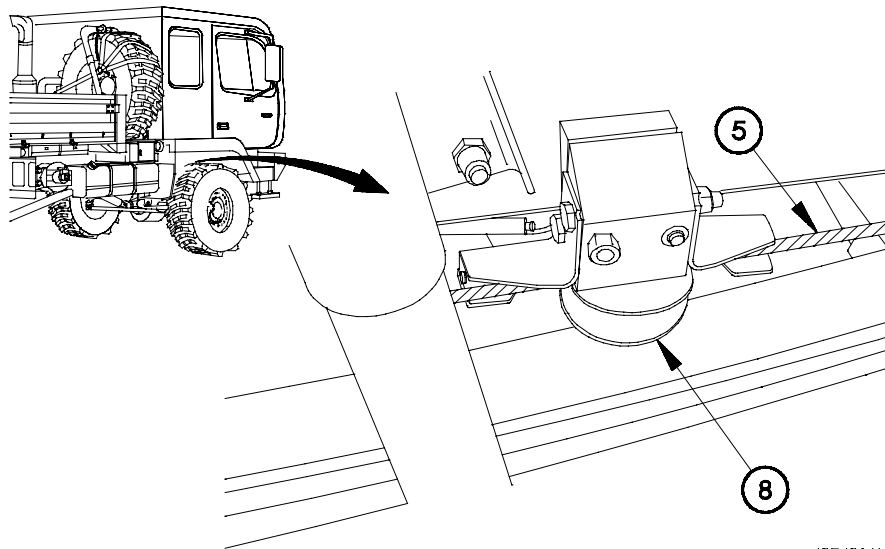


1B54B031

NOTE

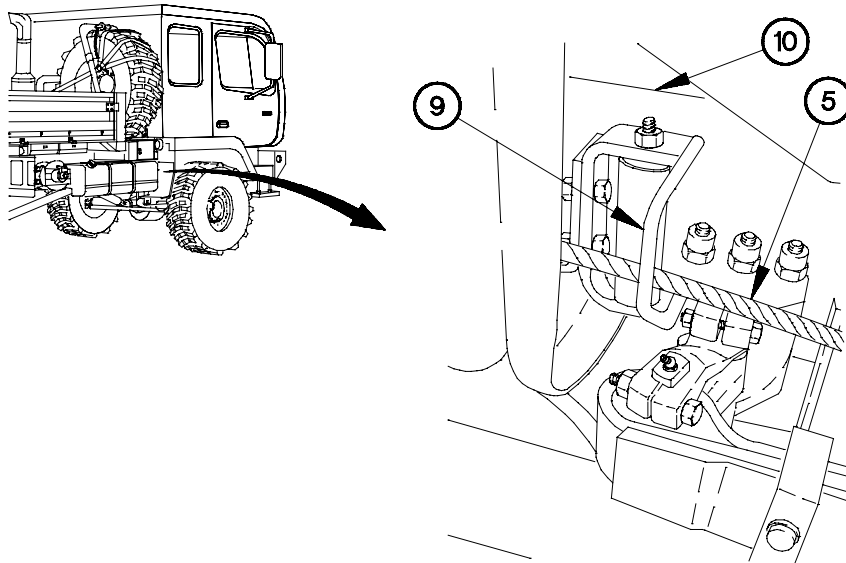
Install retaining pin so that clasping end is toward curbside of vehicle.

- (4) Install roller (3) on front roller support (4) with pin (6) and retaining pin (7).



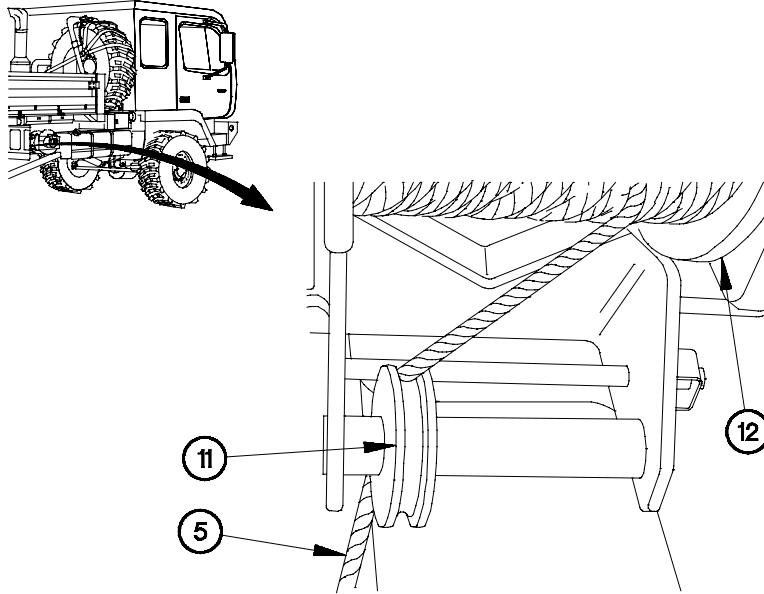
1B54B041

- (5) Remove cable (5) from front cable pulley (8).



1B54B051

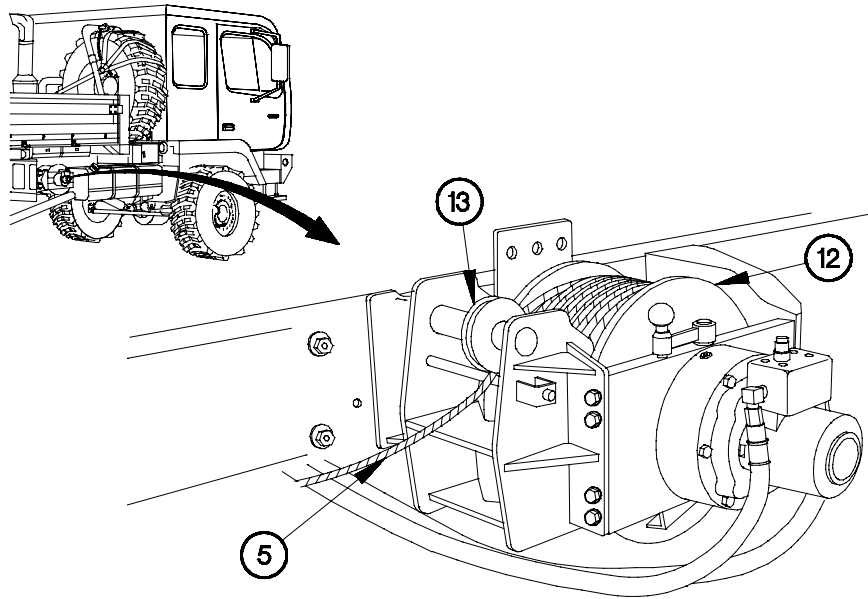
(6) Remove cable (5) from cable guide (9) behind fuel tank (10).



1B54B061

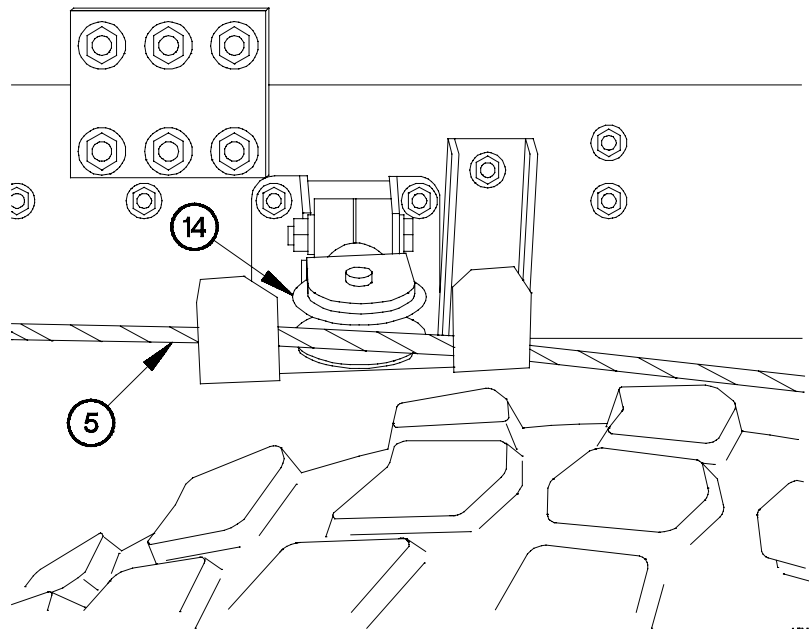
(7) Remove cable (5) from front cable guide (11) on 11K SRW (12).

2-54. 11K SELF-RECOVERY WINCH (SRW) OPERATION (CONT)



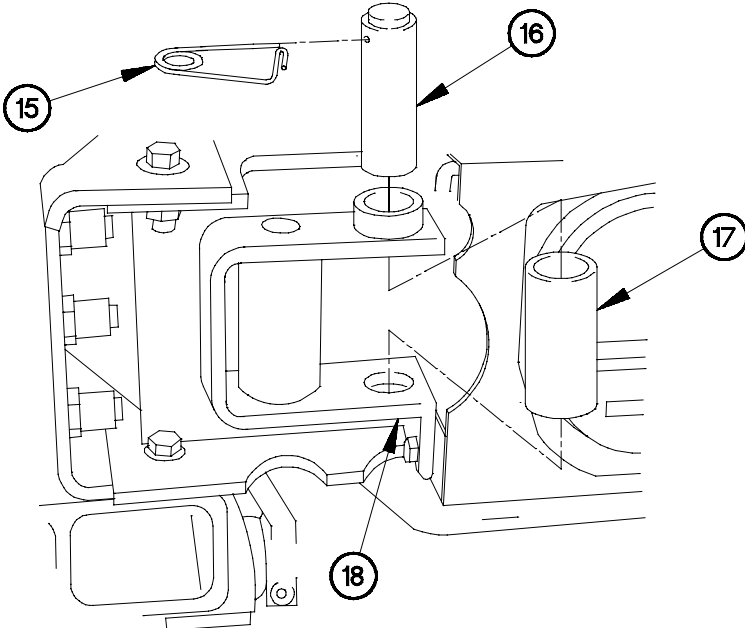
1B54B071

- (8) Position cable (5) toward rear of vehicle.
- (9) Install cable (5) through rear cable guide (13) on 11K SRW (12).



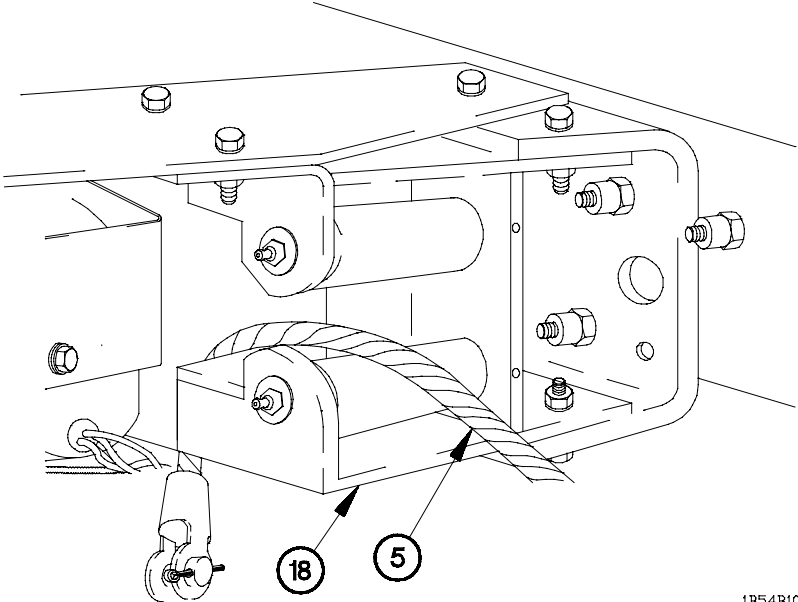
1B54B081

- (10) Install cable (5) through rear cable pulley (14).



1B54B091

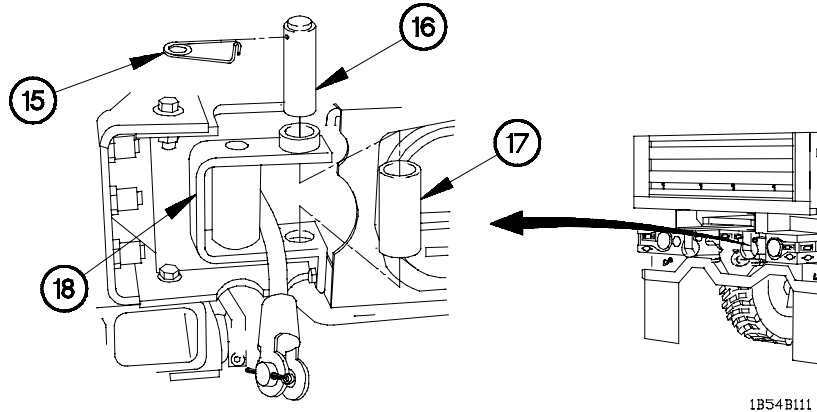
(11) Remove retaining pin (15), pin (16), and roller (17) from rear roller support (18).



1B54B101

(12) Install cable (5) through rear roller support (18).

2-54. 11K SELF-RECOVERY WINCH (SRW) OPERATION (CONT)



(13) Install roller (17) in rear roller support (18) with pin (16) and retaining pin (15).

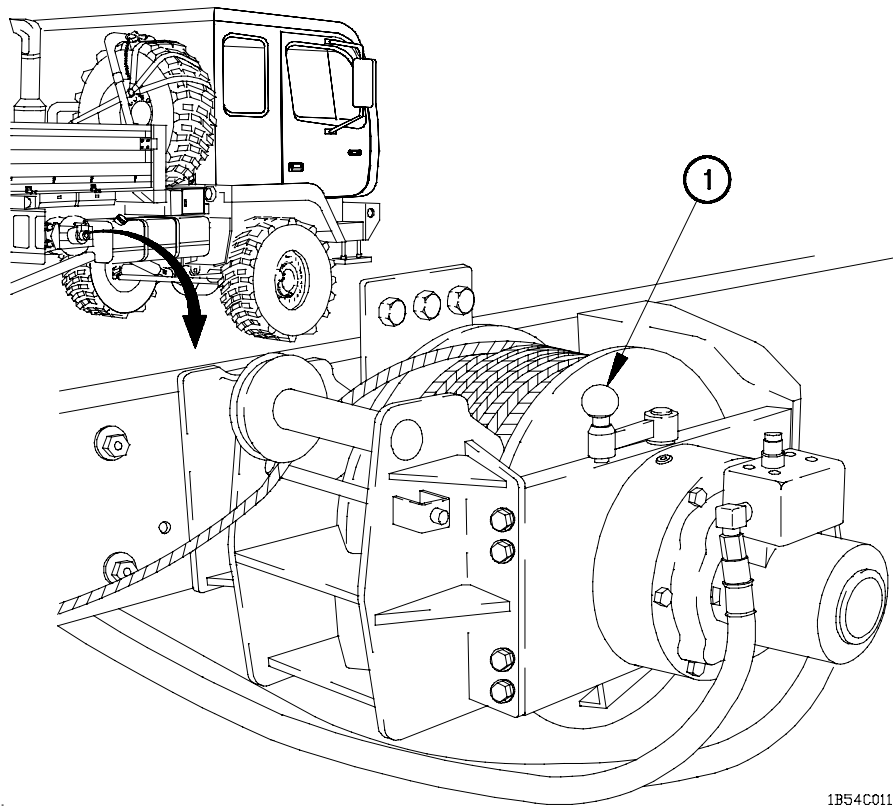
c. 11K SRW Operation.

WARNING

Ensure line pull does not exceed capacity of 11K Self-Recovery Winch (SWR). Failure to comply may result in serious injury or death to personnel.

Table 2-8. 11K Self-Recovery Winch (SRW) Pull Capacity

Cable Layer	Maximum Line Pull
Bottom Layer (five wraps)	11,000 lbs (48,928 N)
2nd Layer	9,970 lbs (44,347 N)
3rd Layer	9,110 lbs (40,521 N)
4th Layer	8,390 lbs (37,319 N)
5th Layer	7,780 lbs (34,605 N)
6th Layer	7,250 lbs (32,248 N)
Top Layer	6,780 lbs (30,157 N)



- (1) Shut down engine (para 2-21f).

WARNING

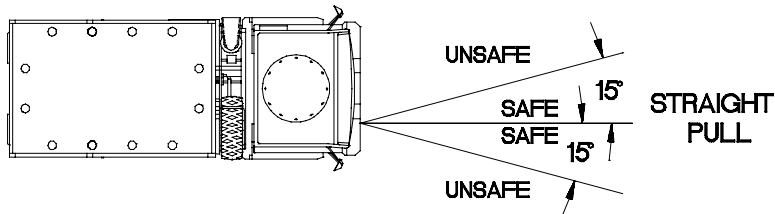
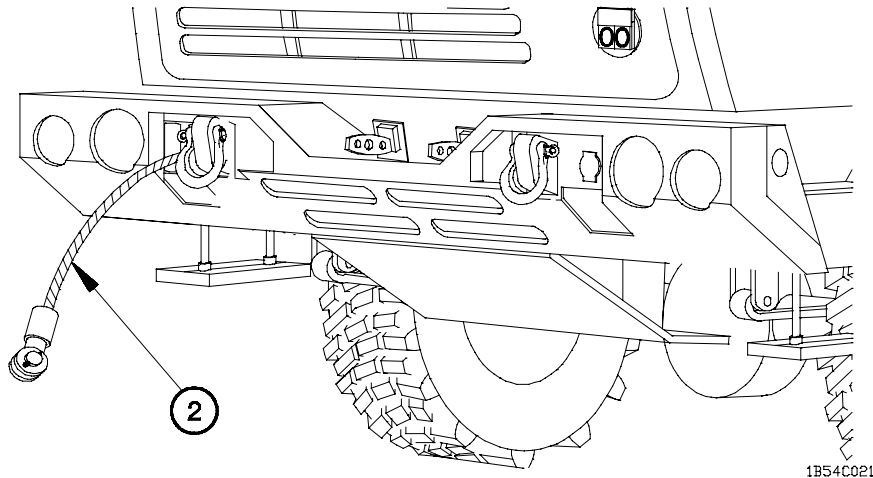
There must always be at least five wraps of cable on 11K Self-Recovery Winch (SRW). If load is applied with less than five wraps of cable on 11K SRW, cable may come loose on drum. Failure to comply may result in serious injury or death to personnel.

CAUTION

Do not attempt to pull load over 11K Self-Recovery Winch (SRW) capacity. Failure to comply may result in damage to equipment.

- (2) Place 11K SRW clutch control lever (1) in DISENGAGED position.

2-54. 11K SELF-RECOVERY WINCH (SRW) OPERATION (CONT)



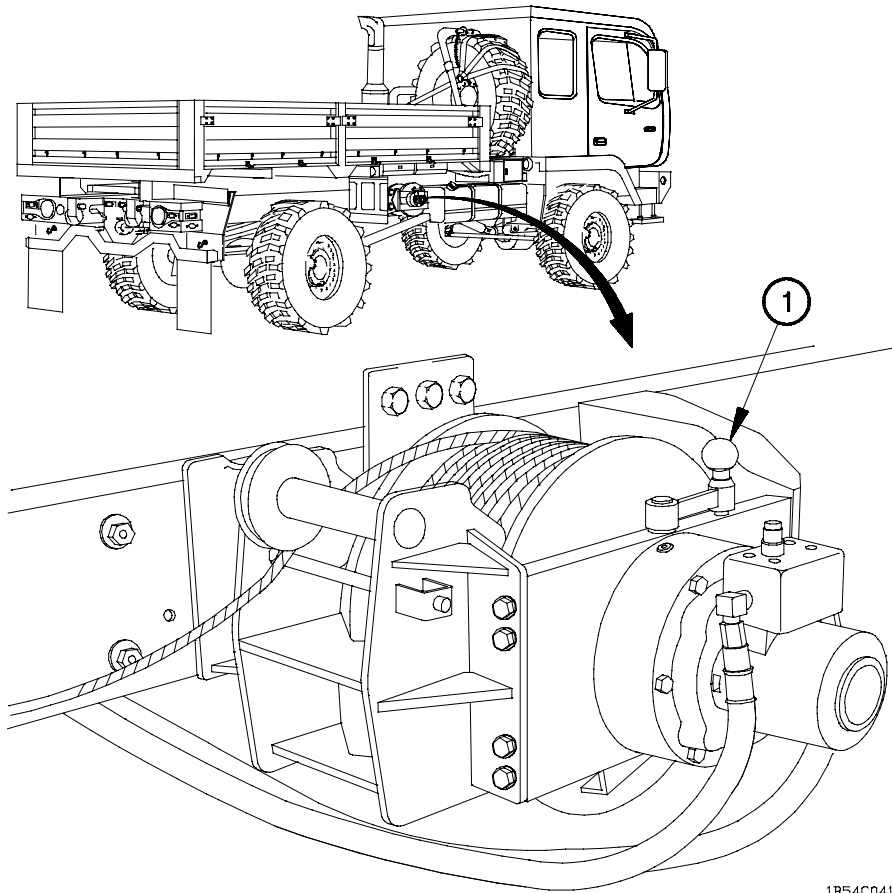
WARNING

Wear heavy leather-palmed work gloves when handling cable. Cables can become frayed or contain broken wires. Never let moving cable slide through hands, even when wearing gloves. Failure to comply may result in injury to personnel.

CAUTION

Do not attach cable to any object more than approximately 15 degrees away from a straight 11K Self-Recovery Winch (SRW) pull. Failure to comply may result in damage to equipment.

- (3) Pull out cable (2) and attach to secure object.



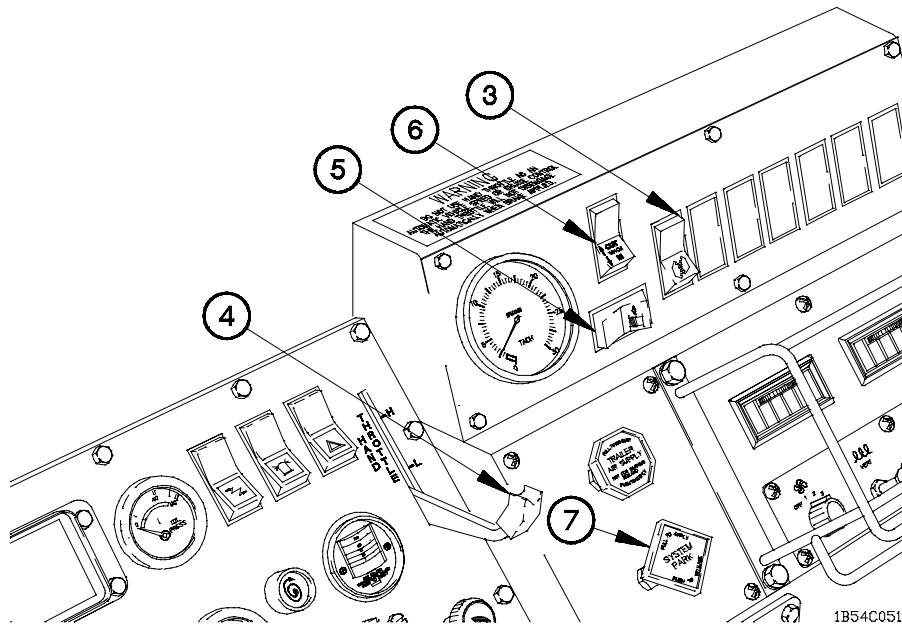
1B54C041

WARNING

Keep all personnel clear of area when tension is on cable. Failure to comply may result in serious injury or death to personnel.

- (4) Place 11K SRW clutch control lever (1) in the ENGAGED position.
- (5) Start engine (para 2-21a or b).

2-54. 11K SELF-RECOVERY WINCH (SRW) OPERATION (CONT)



- (6) Position PTO switch (3) to on.

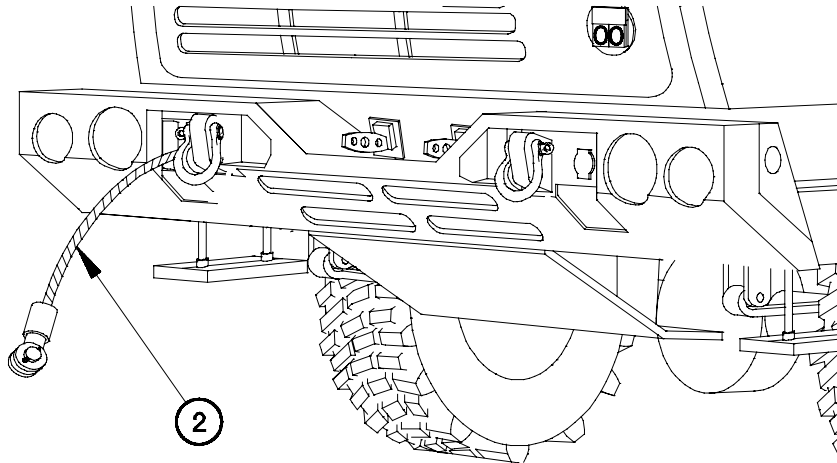
CAUTION

Keep tachometer within 1,250-1,450 rpm when Power Take-Off (PTO) is engaged. Failure to comply may result in damage to equipment.

NOTE

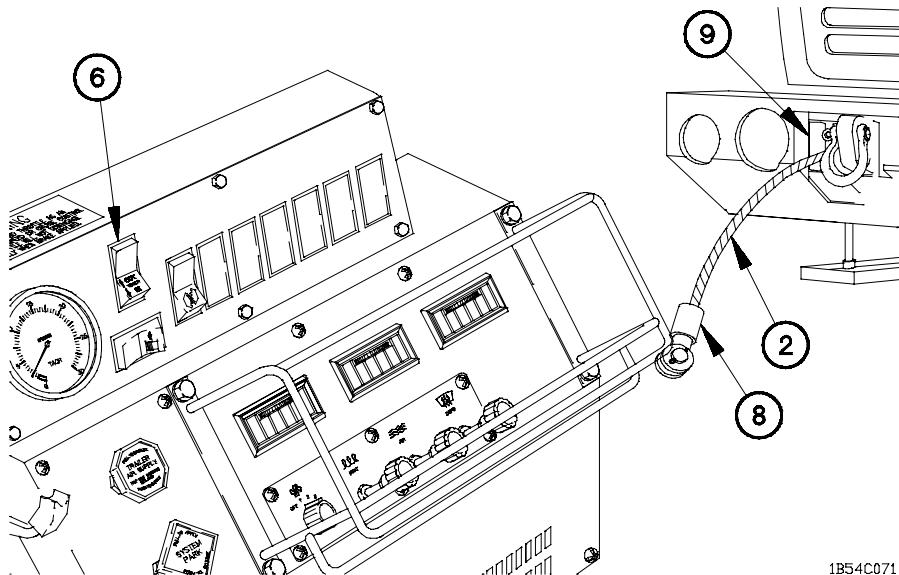
In the event of a tachometer failure a HAND THROTTLE lever positioned to L is approximately 1,250-1,450 rpm.

- (7) Set engine speed to 1,250-1,450 rpm or place HAND THROTTLE lever (4) to L.
- (8) Position winch switch (5) to on.
- (9) Hold WINCH IN/OUT switch (6) in the WINCH IN position until vehicle is recovered.
- (10) Release WINCH IN/OUT switch (6).
- (11) Pull out SYSTEM PARK control (7).



1B54C061

(12) Remove cable (2) from secure object.

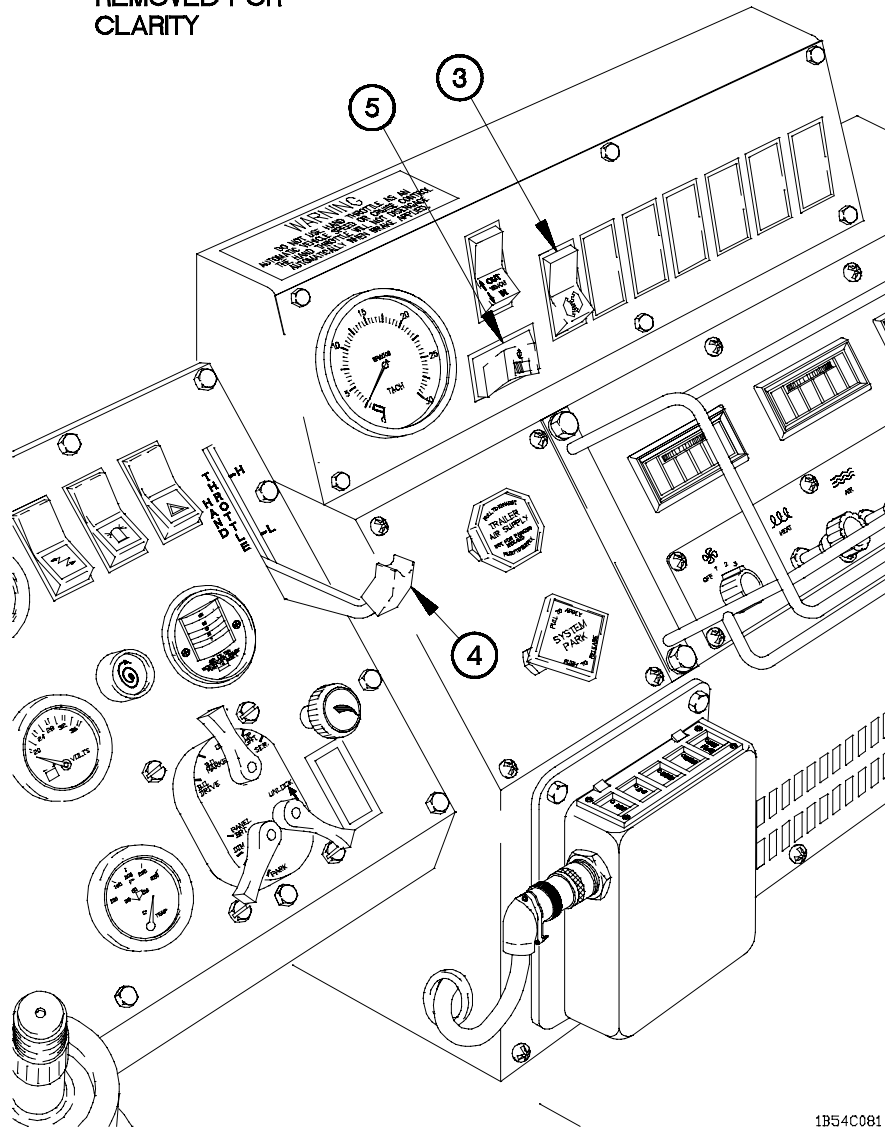


1B54C071

(13) Hold WINCH IN/OUT switch (6) in the WINCH IN position to reel in cable (2) until cable socket (8) contacts rollers (9).

2-54. 11K SELF-RECOVERY WINCH (SRW) OPERATION (CONT)

STEERING WHEEL
REMOVED FOR
CLARITY



1B54C081

- (14) Position winch switch (5) to off.
- (15) Set engine speed to idle (750 rpm) or decrease HAND THROTTLE lever (4) to full down position.
- (16) Position PTO switch (3) to off.

2-55. DELETED

a. Deleted.

All data on pages 2-347
through 2-354, including
pages 2-349 through 2-354 deleted.

Change 1

2-347/(2-348 Blank)

2-56. EMERGENCY PROCEDURES

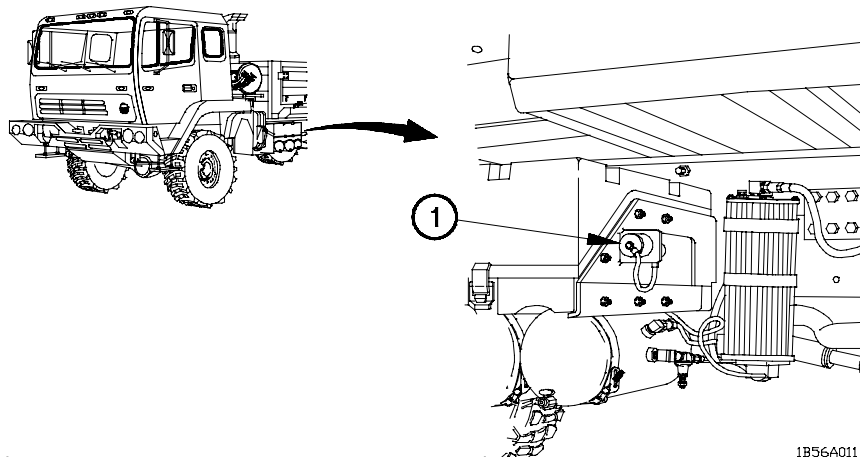
WARNING

- Remove rings, bracelets, wristwatches, neck chains, and any other jewelry before working around the vehicle. Jewelry may catch on equipment, or may short across an electrical circuit or battery terminal. Failure to comply may result in serious injury or death to personnel.
- Do not smoke, have open flame, or make sparks near batteries when starting vehicle. Batteries can explode. Failure to comply may result in serious injury or death to personnel.

a. Starting Disabled Vehicle.

NOTE

Notify Unit Maintenance if vehicle was started by another vehicle.



1B56A011

- (1) Position service vehicle next to disabled vehicle so NATO receptacles (1) are facing each other.

WARNING

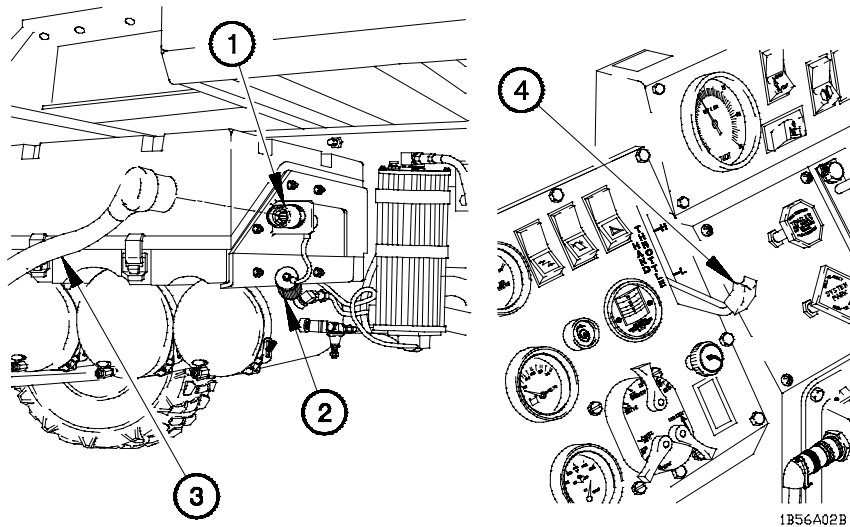
Ensure master power switch on both vehicles is turned off before connecting NATO power cable. Ensure vehicles are not touching each other. Failure to comply may result in electrical shock.

- (2) Shut down engine (para 2-21f).

2-56. EMERGENCY PROCEDURES (CONT)

CAUTION

Always connect NATO power cable to disabled vehicle before connecting it to service vehicle. Failure to comply may result in damage to batteries or cable.

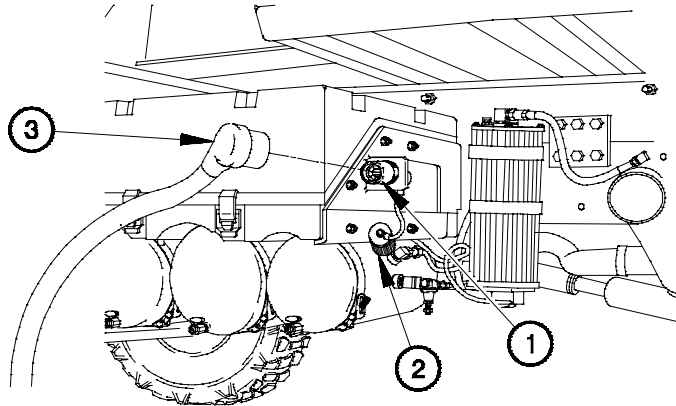


- (3) Remove cap (2) from NATO receptacle (1) on disabled vehicle.
- (4) Install NATO power cable (3) on NATO receptacle (1) on disabled vehicle.
- (5) Remove cap (2) from NATO receptacle (1) on service vehicle.
- (6) Install NATO power cable (3) on NATO receptacle (1) on service vehicle.

NOTE

Steps (7) through (9) require the aid of an assistant.

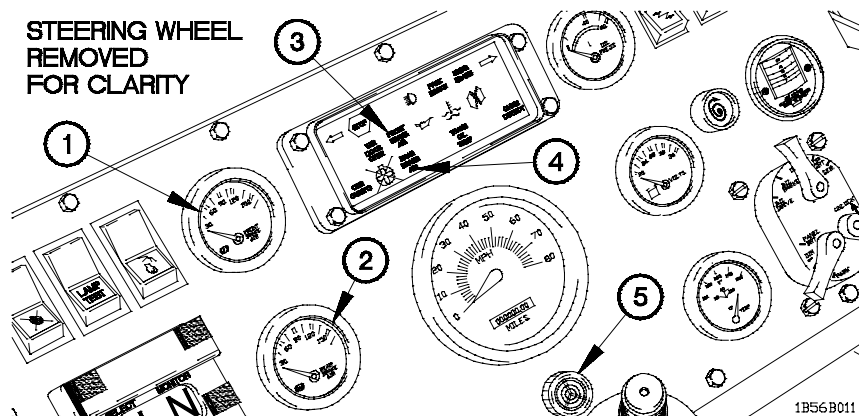
- (7) Start engine (para 2-21a or b) on service vehicle.
- (8) Set engine speed to 1,250 to 1,450 rpm by placing HAND THROTTLE lever (4) to L.
- (9) Start engine of disabled vehicle (para 2-21a or b).



1B56A03B

- (10) Remove NATO power cable (3) from NATO receptacle (1) on disabled vehicle.
- (11) Install cap (2) on NATO receptacle (1) on disabled vehicle.
- (12) Remove NATO power cable (3) from NATO receptacle (1) on service vehicle.
- (13) Install cap (2) on NATO receptacle (1) on service vehicle.
- (14) Stow NATO power cable (3) in stowage box.

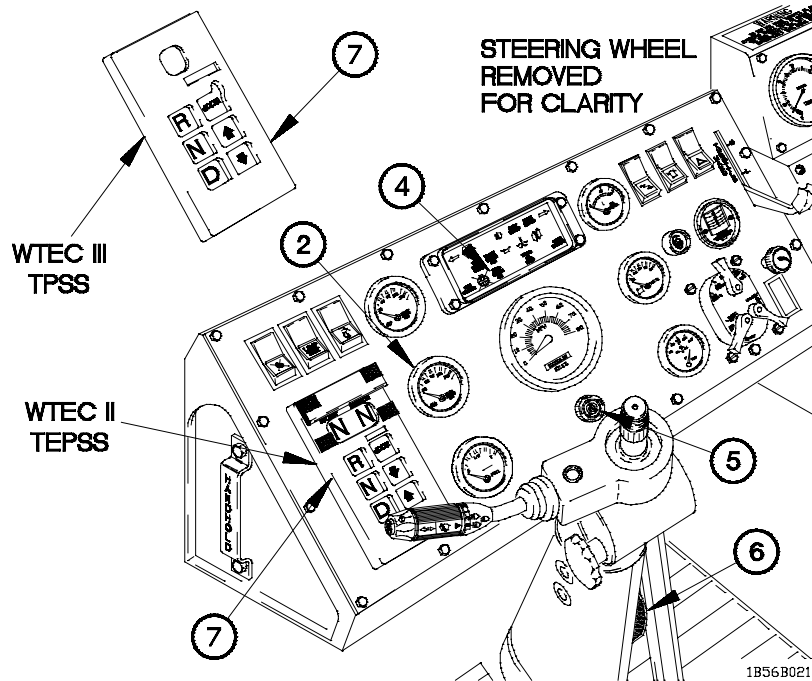
b. Loss in Air Pressure.



1B56B011

- (1) Check FRONT BRAKE AIR and REAR BRAKE AIR pressure gages (1 and 2) if FRONT BRAKE AIR or REAR BRAKE AIR indicator(s) (3 and 4) illuminate and audible alarm (5) sounds while driving vehicle.

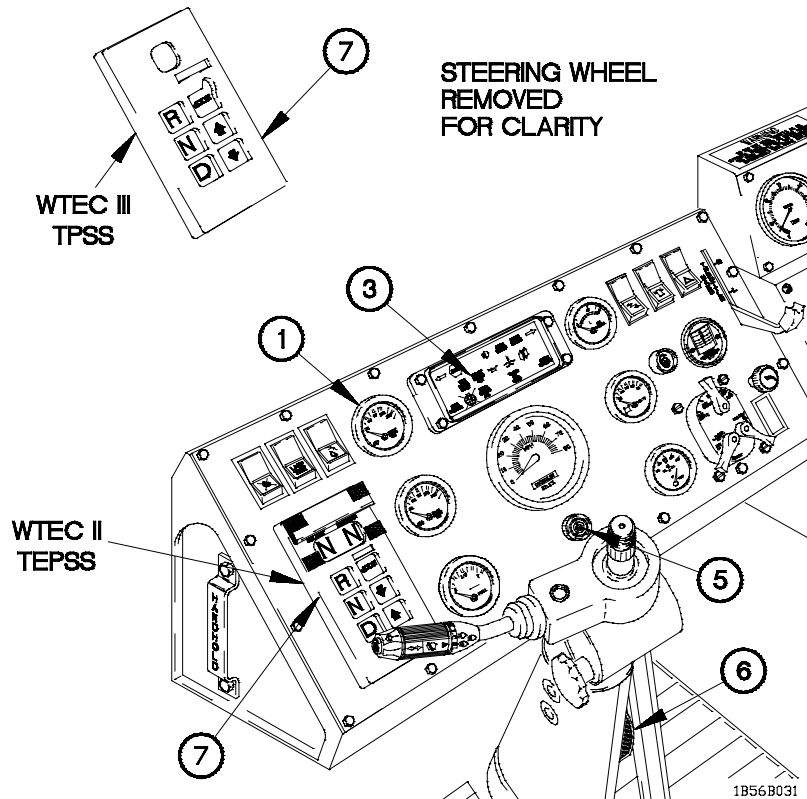
2-56. EMERGENCY PROCEDURES (CONT)



WARNING

Rear axle service brakes will not operate if REAR BRAKE AIR pressure gage reads below 65 psi (448 kPa). Rear axle braking will be provided by rear spring brakes for a limited time. Allow greater stopping distance. Discontinue vehicle operation as soon as possible. Failure to comply may result in serious injury or death to personnel.

- (2) If REAR BRAKE AIR pressure gage (2) reads below 65 psi (448 kPa), REAR BRAKE AIR indicator (4) illuminates, and audible alarm (5) sounds:
 - (a) Leave additional distance between vehicles.
 - (b) Apply brake pedal (6) earlier than usual when slowing vehicle.
 - (c) Downshift to lower gear range using WTEC II TEPSS (7) or WTEC III TPSS (7).
 - (d) Notify Unit Maintenance as soon as possible.

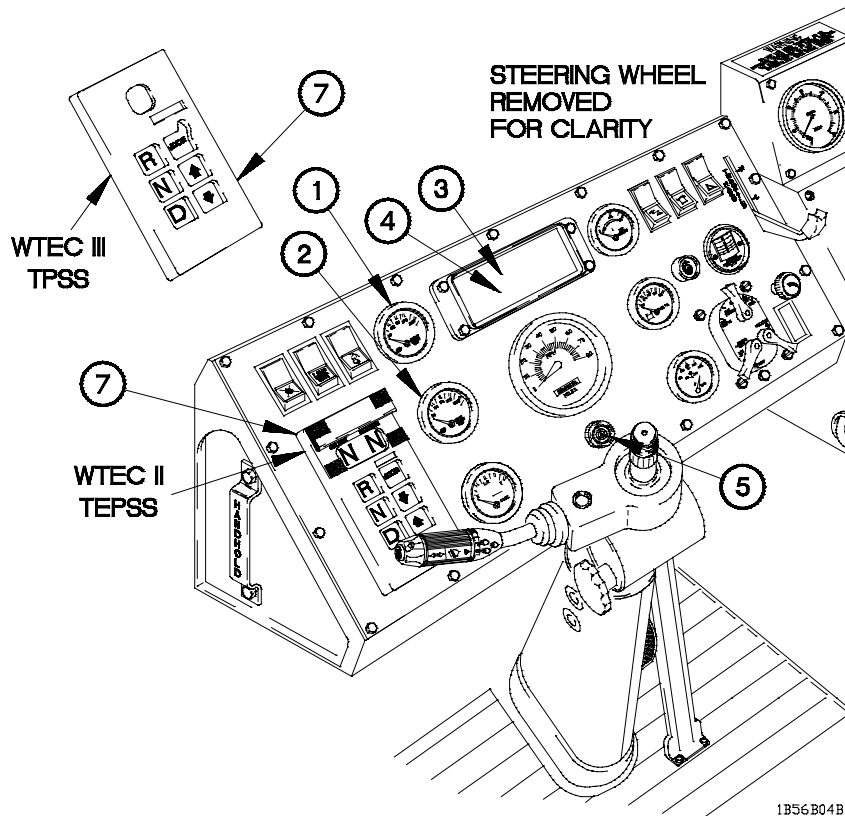


WARNING

Front axle service brakes will not operate if FRONT BRAKE AIR pressure gage reads below 65 psi (448 kPa). Allow greater stopping distance. Discontinue vehicle operation as soon as possible. Failure to comply may result in serious injury or death to personnel.

- (3) If FRONT BRAKE AIR pressure gage (1) reads below 65 psi (448 kPa), FRONT BRAKE AIR indicator (3) illuminates and audible alarm (5) sounds:
 - (a) Leave additional distance between vehicles.
 - (b) Apply brake pedal (6) earlier than usual when slowing vehicle.
 - (c) Downshift to lower gear range using WTEC II TEPSS (7) or WTEC III TPSS (7).
 - (d) Notify Unit Maintenance as soon as possible.

2-56. EMERGENCY PROCEDURES (CONT)



(4) If FRONT BRAKE AIR pressure gage (1) or REAR BRAKE AIR pressure gage (2) read below 65 psi (448 kPa), FRONT BRAKE AIR indicator (3) or REAR BRAKE AIR indicator (4) illuminate, and audible alarm (5) sounds:

- (a) Look for place to stop vehicle without blocking other traffic.
- (b) Downshift to lower gear range using WTEC II TEPSS (7) or WTEC III TPSS (7) to control vehicle speed until place to stop is found.
- (c) Stop vehicle.
- (d) Notify Unit Maintenance.

c. Nuclear, Biological, and Chemical (NBC) Decontamination.

Refer to TB 700-4 for nuclear, biological, and chemical (NBC) defense procedures. Refer to FM 3-5 for chemical, biological, and radiological (CBR) decontamination procedures.

2-57. PREPARATION FOR SHIPMENT

WARNING

- Heavy objects/loads, such as tool boxes and heavy parts, must always be carried on the floor with the weight distributed as equally as possible between left and right sides of M1079 van. Failure to comply decreases the stability of the M1079 van and will increase the likelihood of a rollover.
- Heavy cabinets must always be mounted as low as possible with the weight distributed as equally as possible between left and right sides of M1079 van. Remember to consider the weight of the items that will be stored in the cabinets. Failure to comply decreases the stability of the M1079 van and will increase the likelihood of a rollover.
- Always keep in mind, when placing items inside the M1079 van, that heavier items must always be positioned as low as possible and the weight distributed as equally as possible between left and right sides of M1079 van. Failure to comply decreases the stability of the M1079 van and will increase the likelihood of a rollover.

a. Land, Sea, and Air Shipment.

Instructions for shipment of the vehicle by land, sea, and air are contained in the following publications:

MTMCTEA Pam 56-1	Marine Terminal Lifting Guidance
MTMCTEA Pam 55-19	Tiedown Handbook for Rail Movements
MTMCTEA Ref 92-55-20	Tiedown Handbook for Truck Movements
FM 10-520	Airdrop of Supplies and Equipment: Rigging 2 1/2-Ton Trucks
FM 55-450-3	Multi-service Helicopter External Air Transport: Basic Operations and Equipment
FM 55-450-4	Multi-service Helicopter External Air Transport: Single-Point Load Rigging Procedures
FM 55-450-5	Multi-service Helicopter External Air Transport: Dual-Point Load Rigging Procedures
TB 55-46-1	Standard Characteristics (Dimensions, Weight, and Cube) for Transportability of Military Vehicles and Other Outsize/Overweight Equipment (in TOE Line Item Number Sequence)

2-57. PREPARATION FOR SHIPMENT (CONT)

b. Preparation of Internal Air Transport Procedure.

The Preparation for Internal Air Transport procedure for reducing cab height is contained in para 2-58.

c. Tie Down and Helicopter-Lift.

Vehicle Tie Down and Helicopter-Lift instructions are contained on Model Weight and Dimensional Data Plates (para 2-42).

d. Preparation for Air Drop.

Perform M1081 Air Drop Preparation (para 3-10).

e. Preparation for Highway or Rail Shipment.

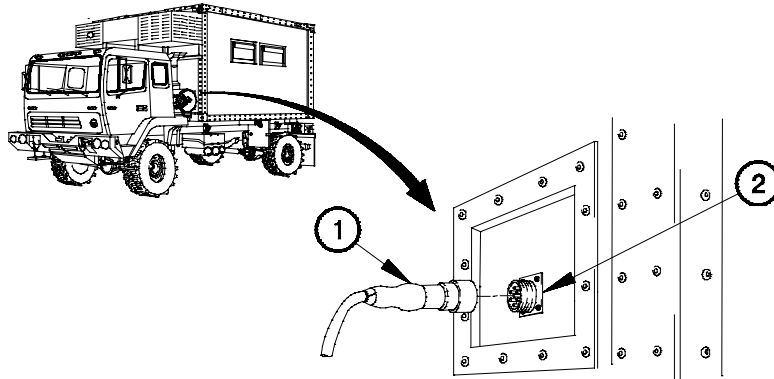
Cab air springs must be deflated and pinned for shipment (para 2-58b). Upon arrival at destination cab air springs must be unpinned and inflated (para 2-58g). Two drain plugs must be loosened on M1079 Van prior to shipment.

2-58. PREPARATION FOR INTERNAL AIR TRANSPORT, HIGHWAY, OR RAIL SHIPMENT

WARNING

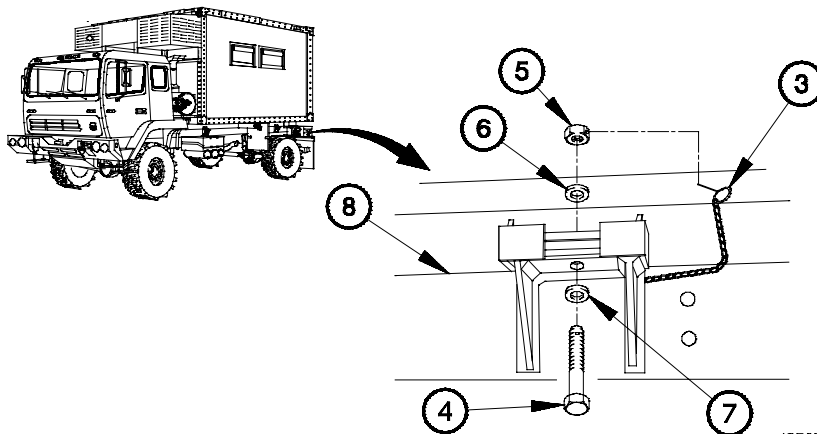
- **Heavy objects/loads, such as tool boxes and heavy parts, must always be carried on the floor with the weight distributed as equally as possible between left and ride sides of M1079 van. Failure to comply decreases the stability of the M1079 van and will increase the likelihood of a rollover.**
- **Heavy cabinets must always be mounted as low as possible with the weight distributed as equally as possible between left and right sides of M1079 van. Remember to consider the weight of the items that will be stored in the cabinets. Failure to comply decreases the stability of the M1079 van and will increase the likelihood of a rollover.**
- **Always keep in mind, when placing items inside the M1079 van, that heavier items must always be positioned as low as possible and the weight distributed as equally as possible between left and right sides of M1079 van. Failure to comply decreases the stability of the M1079 van and will increase the likelihood of a rollover.**

a. Van Body Removal.



1B58R01B

- (1) Disconnect connector P173 (1) from connector J173 (2).



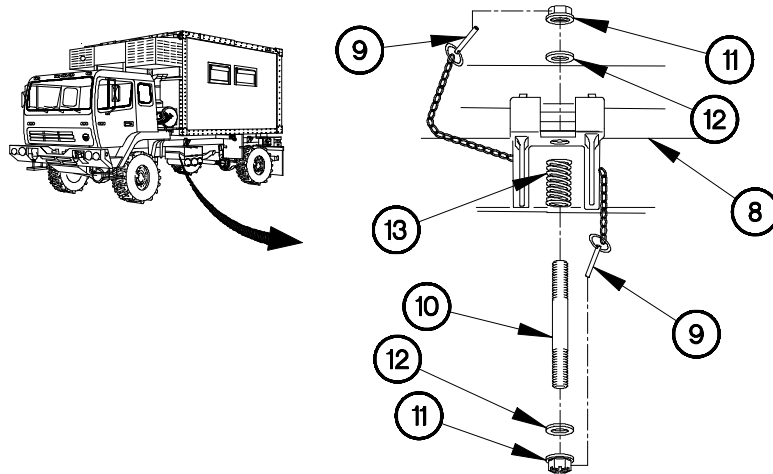
1B58R02B

NOTE

Left and right van body mounting hardware is removed the same way.
Left side shown.

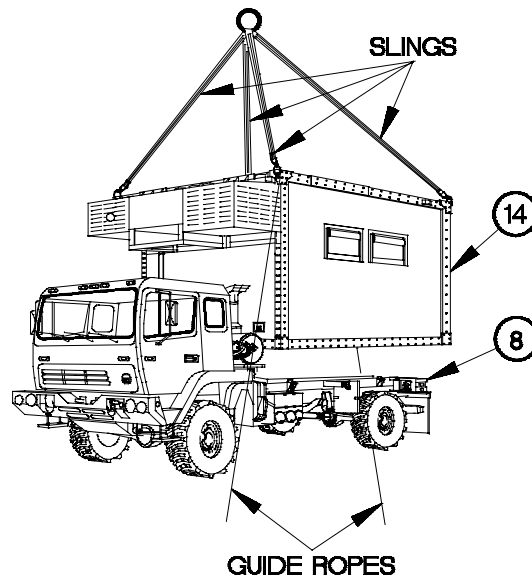
- (2) Remove lynch pin (3) from bolt (4).
 (3) Remove slotted nut (5), washer (6), bolt (4), and washer (7) from subframe (8).

**2-58. PREPARATION FOR INTERNAL AIR TRANSPORT,
HIGHWAY OR RAIL SHIPMENT (CONT)**



1B58R03B

- (4) Remove two lynch pins (9) from stud (10).
- (5) Remove two slotted nuts (11), washers (12), stud (10), and spring (13) from subframe (8).
- (6) Perform steps (2) through (5) on right side of van body.



1B59R04B

WARNING

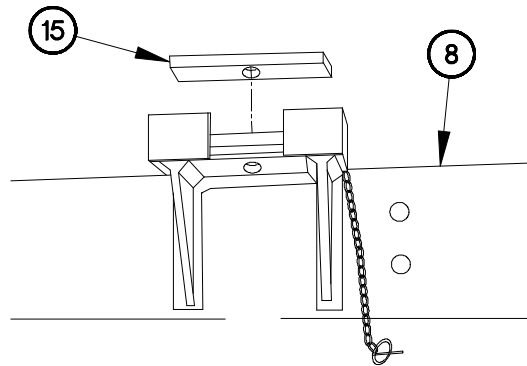
- Van body weighs approximately 3360 lbs (1525 kgs) empty. Attach a suitable lifting device prior to removal. Failure to comply may result in injury or death to personnel.
- Guide ropes must be attached at opposite corners of van body to aid in controlling van body during removal. Failure to comply may result in serious injury or death to personnel.
- Center of gravity will change depending on equipment installed in van body. Attach and adjust lifting device so that van body lifts level. Failure to comply may result in serious injury or death to personnel or damage to equipment.

NOTE

Step (7) requires the aid of two assistants.

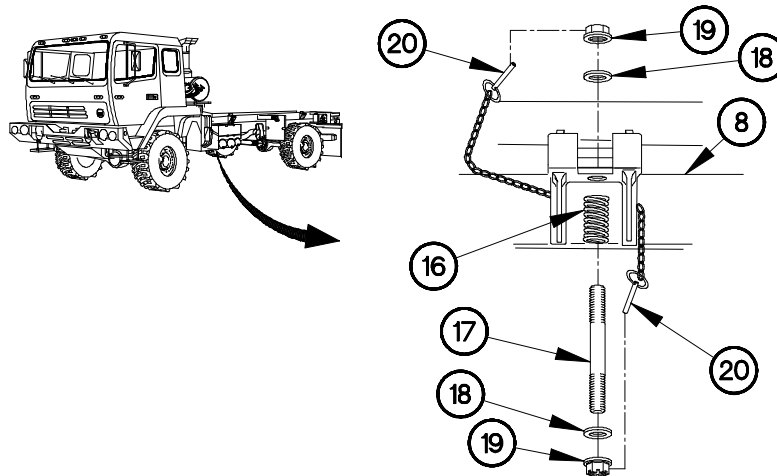
(7) Remove van body (14) from subframe (8).

**2-58. PREPARATION FOR INTERNAL AIR TRANSPORT,
HIGHWAY OR RAIL SHIPMENT (CONT)**



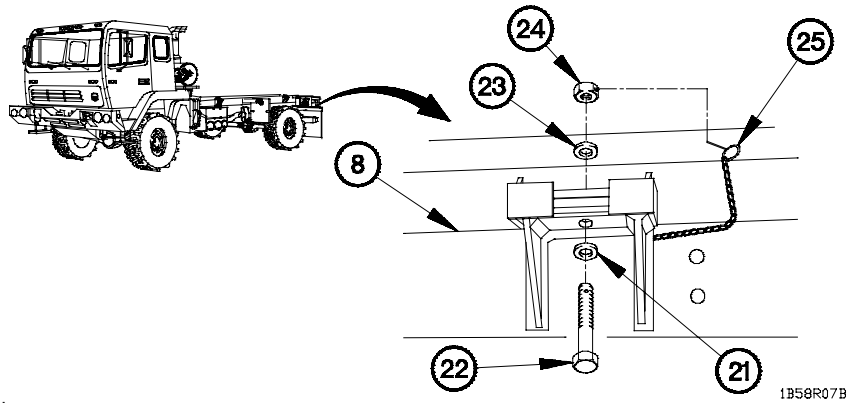
1B58R05B

- (8) Remove four cushioning pads (15) from subframe (8) and store in tool box.



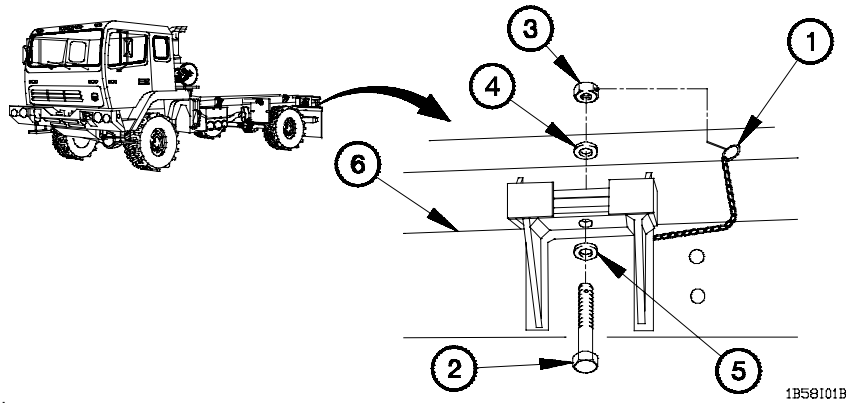
1B58R06B

- (9) Install spring (16), stud (17), and two washers (18) in subframe (8) with two slotted nuts (19).
- (10) Install two lynch pins (20) in stud (17).
- (11) Perform steps (9) and (10) on opposite side of subframe (8).



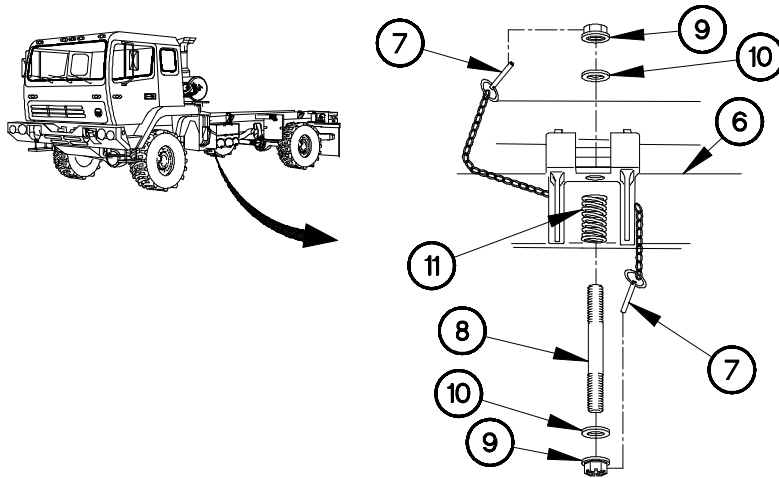
- (12) Install washer (21), bolt (22), and washer (23) in subframe (8) with slotted nut (24).
- (13) Install lynch pin (25) in bolt (22).
- (14) Perform steps (12) and (13) on opposite side of subframe (8).

b. Van Body Installation.



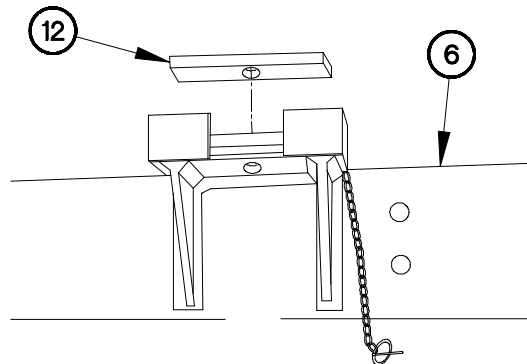
- (1) Remove lynch pin (1) from bolt (2).
- (2) Remove slotted nut (3), washer (4), and washer (5) from subframe (6).
- (3) Perform steps (1) and (2) on opposite side of subframe (6).

**2-58. PREPARATION FOR INTERNAL AIR TRANSPORT,
HIGHWAY OR RAIL SHIPMENT (CONT)**



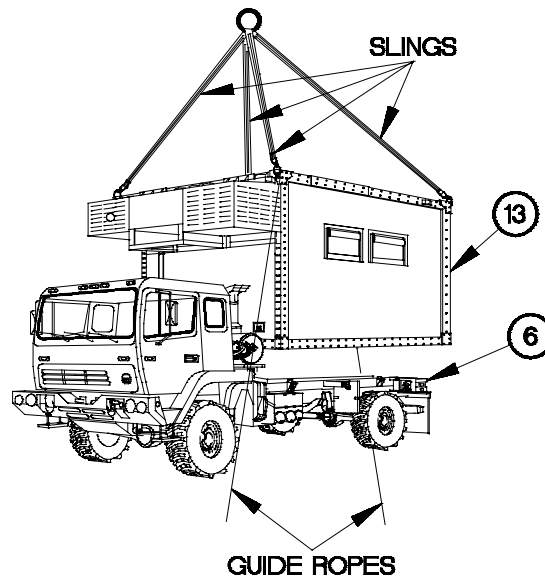
1B58i02B

- (4) Remove two lynch pins (7) from stud (8).
- (5) Remove two slotted nuts (9), washers (10), stud (8), and spring (11) from subframe (6).
- (6) Perform steps (4) and (5) on opposite side of subframe (6).



1B58i03B

- (7) Remove four cushioning pads (12) from tool box and place on subframe (6).



1B58104B

WARNING

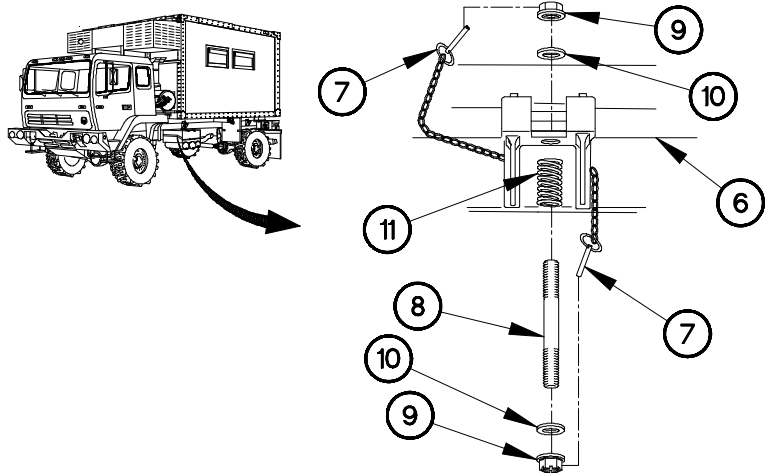
- Van body weighs approximately 3360 lbs (1525 kgs) empty. Attach a suitable lifting device prior to installation. Failure to comply may result in injury or death to personnel.
- Guide ropes must be attached at opposite corners of van body to aid in controlling van body during installation. Failure to comply may result in serious injury or death to personnel.
- Center of gravity will change depending on equipment installed in van body. Attach and adjust lifting device so that van body lifts level. Failure to comply may result in serious injury or death to personnel or damage to equipment.

NOTE

Step (8) requires the aid of two assistants.

- (8) Position van body (13) on subframe (6).

**2-58. PREPARATION FOR INTERNAL AIR TRANSPORT,
HIGHWAY OR RAIL SHIPMENT (CONT)**

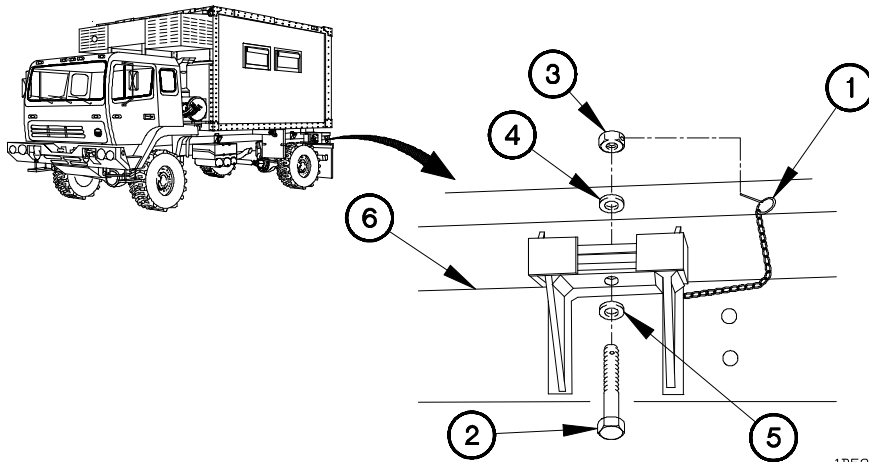


1B58I05B

NOTE

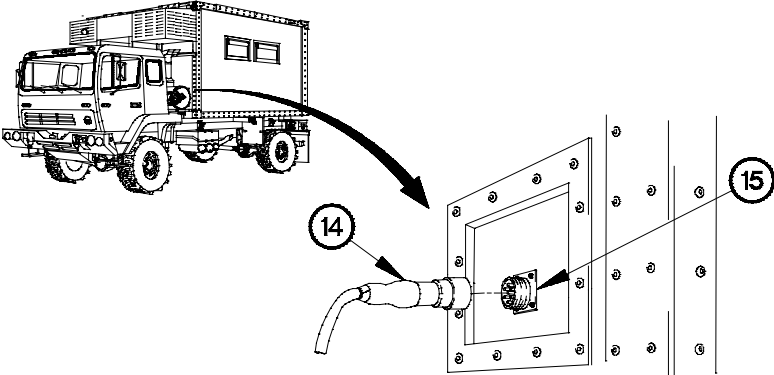
Left and right van body mounting hardware is installed the same way.
Left side shown.

- (9) Install spring (11), stud (8), two washers (10), and slotted nuts (9) in subframe (6).
- (10) Install two lynch pins (7) in stud (8).



1B58I06B

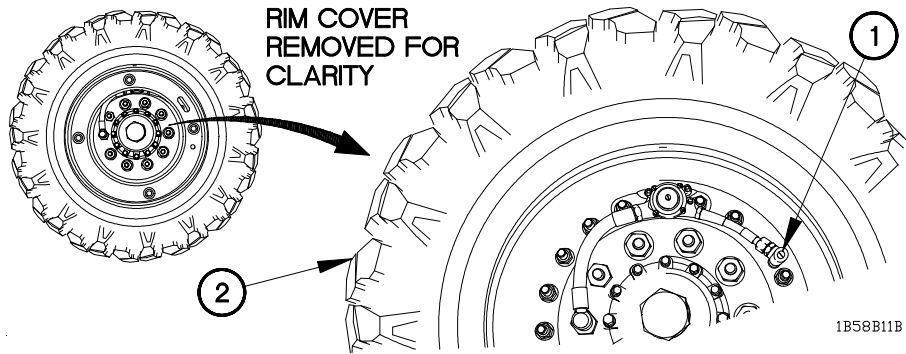
- (11) Install washer (5), bolt (2), washer (4), and slotted nut (3) in subframe (6).
- (12) Install lynch pin (1) in bolt (2).
- (13) Perform steps (9) through (12) on right side of van body.



1B58107B

(14) Connect connector P173 (14) to connector J173 (15).

b.1. Front Tire Deflation.

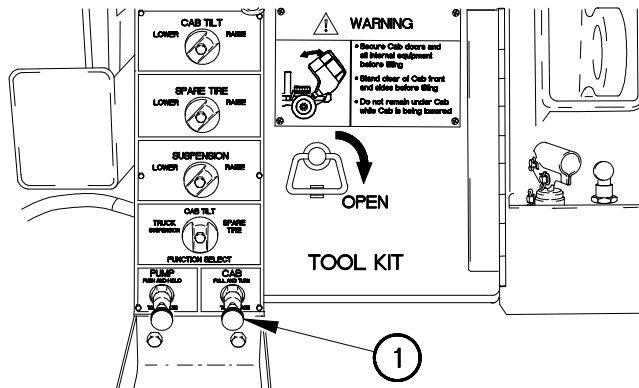


NOTE

- Left and right front tires are deflated the same way. Left front tire shown.
- Tires will deflate until approximately 10 psi (690 kPa) remains in tire.
- Some resistance may be felt when turning kneeling valve. Valve will not operate properly if it is not turned 1/2 turn (180 degrees).

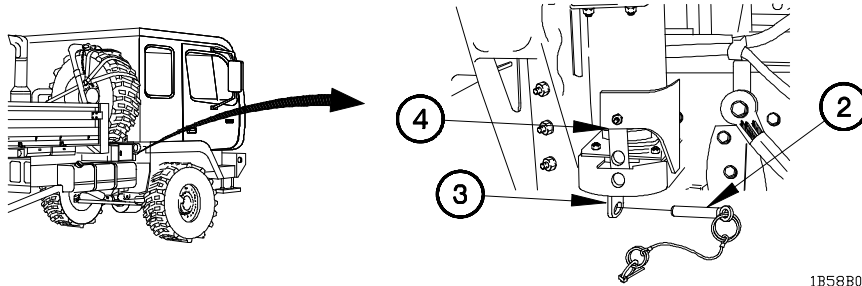
- (1) Depress emergency (EMER) on CTIS ECU (para 2-23).
- (2) Turn kneeling valve (1) 1/2 turn to left (180 degrees) to release air from front tire (2).

b.2. Cab Air Spring Deflation.



- (1) Turn CAB knob (1) to the left and pull out.

**2-58. PREPARATION FOR INTERNAL AIR TRANSPORT,
HIGHWAY OR RAIL SHIPMENT (CONT)**

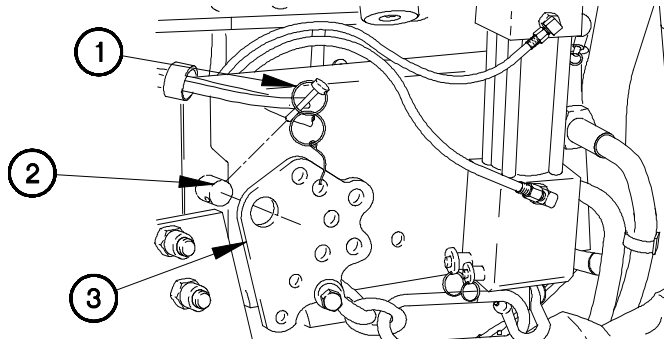


NOTE

Left and right side cab air springs are deflated the same way. Right side cab air spring shown.

- (2) Remove quick release pin (2) from bracket (3).
- (3) Install quick release pin (2) in cab air spring bracket (4).
- (4) Perform steps (2) and (3) on left side of vehicle.

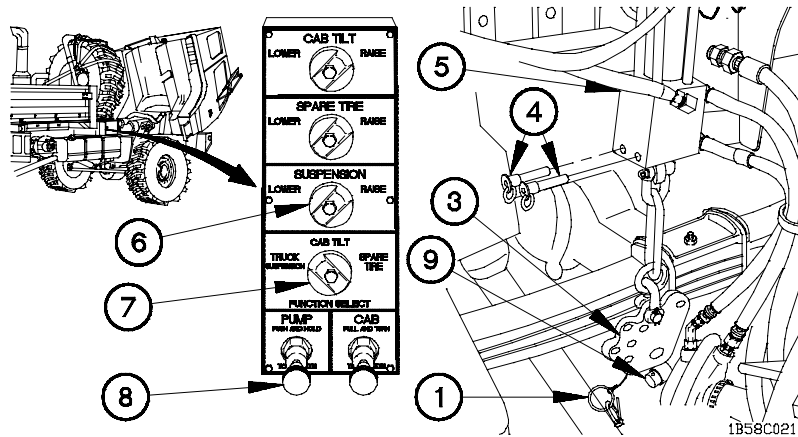
c. Compressing Suspension.



NOTE

Left and right side suspension compression plates are removed the same way. Right side suspension compression plate shown.

- (1) Start engine (para 2-21a or b).
- (2) Raise cab (para 2-22a).
- (3) Remove retaining pin (1) from stud (2).
- (4) Remove suspension compression plate (3) from stud (2).



- (5) Remove two safety pins (4) from compression cylinder (5).
- (6) Perform steps (3) through (5) on left side of vehicle.
- (7) Turn SUSPENSION knob (6) to the RAISE position.
- (8) Turn FUNCTION SELECT knob (7) to the TRUCK SUSPENSION position.

NOTE

Use back-up hydraulic pump (para 2-41) if pressing PUMP knob does not accomplish step (9).

- (9) Press and hold PUMP knob (8) until suspension compression plate (3) can be installed on axle stud (9).

WARNING

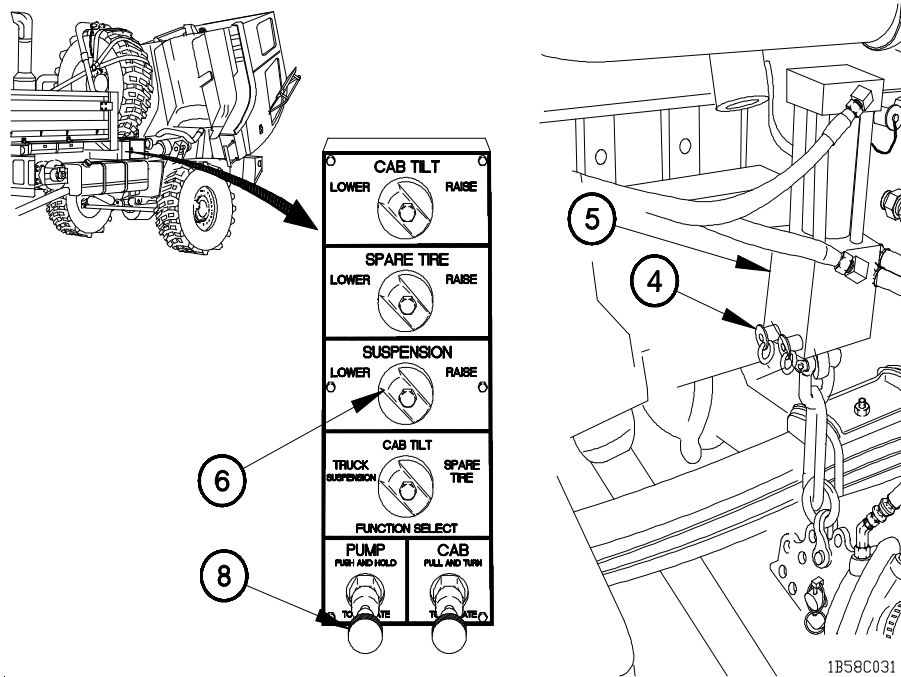
Both suspension compression plates must be installed on axle studs. Failure to comply may result in serious injury or death to personnel.

NOTE

Left and right side suspension compression plates are installed on axle studs the same way. Right side shown.

- (10) Install suspension compression plate (3) on axle stud (9).
- (11) Install pin (1) in axle stud (9).
- (12) Perform steps (10) and (11) on left side of vehicle.

**2-58. PREPARATION FOR INTERNAL AIR TRANSPORT,
HIGHWAY OR RAIL SHIPMENT (CONT)**

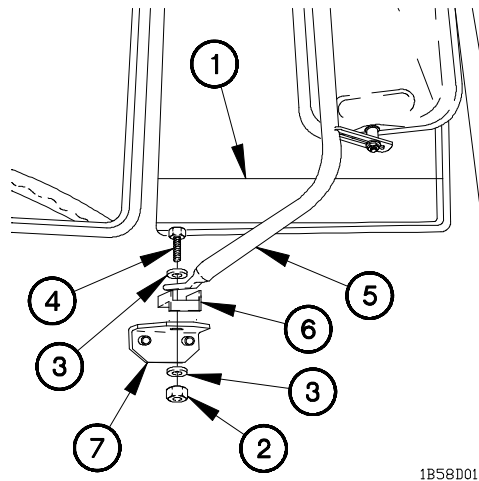


NOTE

- Suspension is fully compressed when cylinder rod is fully retracted and safety pins can be installed in compression cylinder.
- Use back-up hydraulic pump (para 2-41) if pressing PUMP knob does not accomplish step (14).

- (13) Turn SUSPENSION knob (6) to the LOWER position.
- (14) Press and hold PUMP knob (8) until suspension is fully compressed.
- (15) Install two safety pins (4) in compression cylinder (5).
- (16) Perform step (15) on left side of vehicle.
- (17) Lower cab (para 2-22 b).
- (18) Shut down engine (para 2-21f).

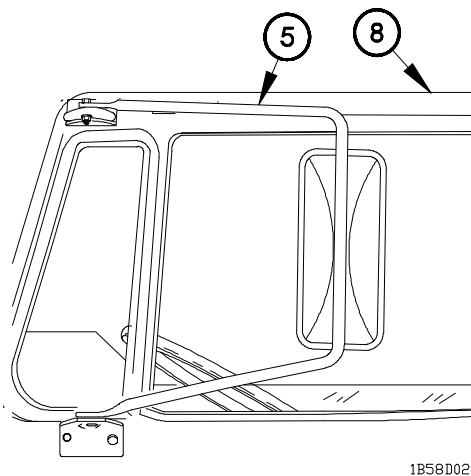
d. Folding Mirrors.



NOTE

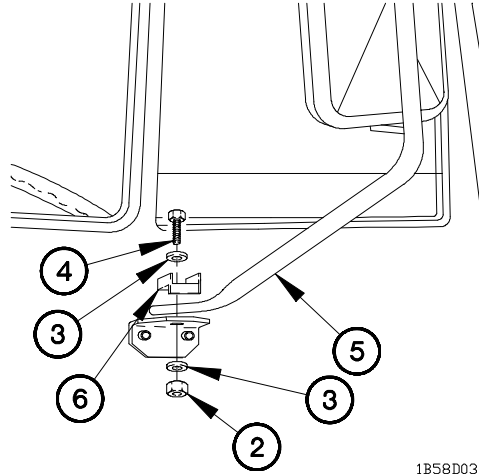
- Left and right side mirrors are folded the same way. Left side mirror shown.
- Perform steps (1) through (6) on Vehicle S/N 15,675 or lower.

- (1) Roll window (1) down completely.
- (2) Remove nut (2), two washers (3), and screw (4) from mirror assembly (5).
- (3) Remove clip (6) from bracket (7).



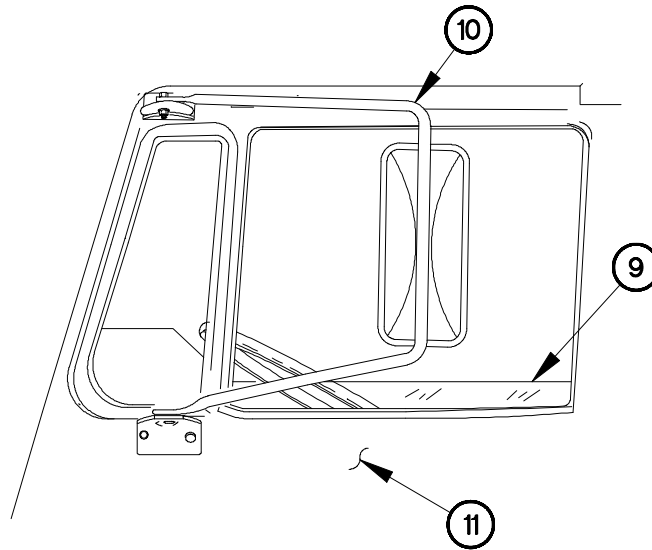
- (4) Fold mirror assembly (5) in toward door (8).

**2-58. PREPARATION FOR INTERNAL AIR TRANSPORT,
HIGHWAY OR RAIL SHIPMENT (CONT)**



1B58D031

- (5) Install clip (6), two washers (3), screw (4), and nut (2) on mirror assembly (5).
- (6) Perform steps (1) through (5) on right side of vehicle.



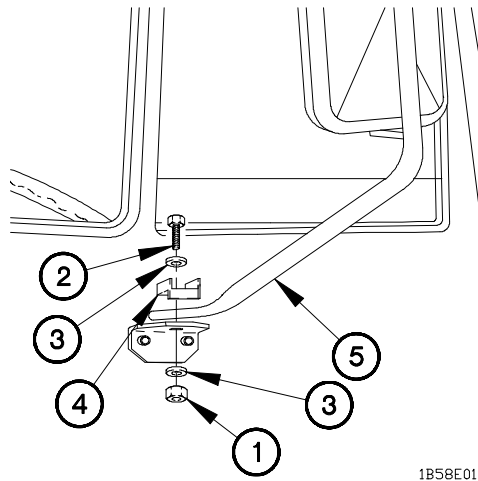
1B58D041

NOTE

Perform steps (7) through (9) on Vehicle S/N 15,676 or higher.

- (7) Roll window (9) down completely.
- (8) Fold mirror assembly (10) toward door (11).
- (9) Perform steps (7) and (8) on right side of vehicle.

e. Unfolding Mirrors.

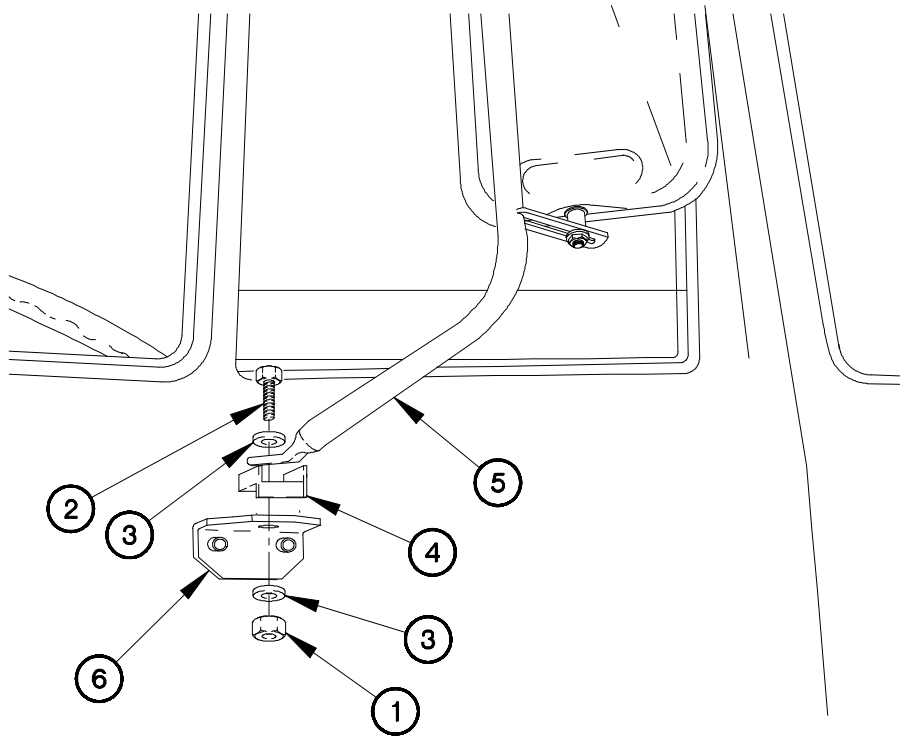


NOTE

- Left and right side mirrors are unfolded the same way. Left side mirror shown.
- Perform steps (1) through (5) on Vehicle S/N 15,675 or lower.

- (1) Remove nut (1), screw (2), two washers (3), and clip (4) from mirror assembly (5).
- (2) Unfold mirror assembly (5).

**2-58. PREPARATION FOR INTERNAL AIR TRANSPORT,
HIGHWAY OR RAIL SHIPMENT (CONT)**



1B58E021

- (3) Install clip (4) between mirror assembly (5) and bracket (6).

NOTE

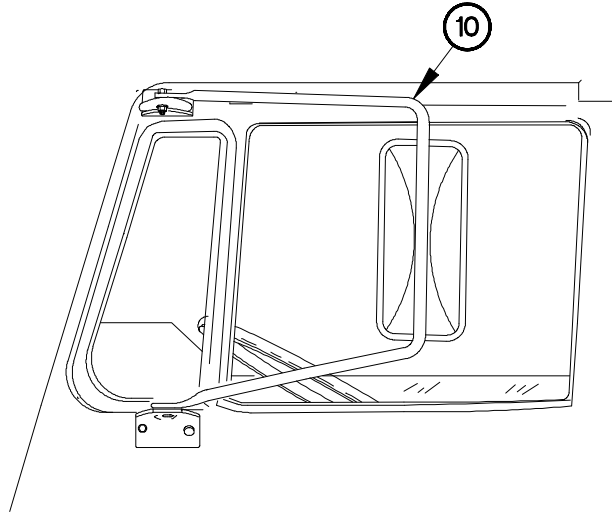
Notify Unit Maintenance to tighten nuts to 21-27 lb-ft (29-37 N·m).

- (4) Install two washers (3), screw (2), and nut (1).
(5) Perform steps (1) through (4) on right side of vehicle.

NOTE

Perform step (6) on Vehicle S/N 15,676 or higher.

(6) Unfold mirror assembly (10).



1B58E031

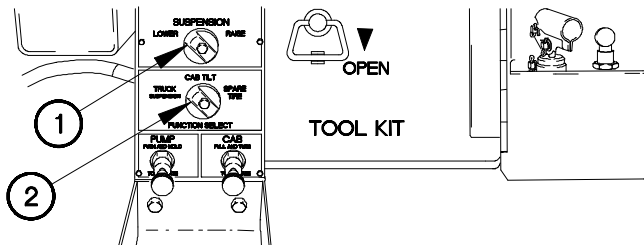
f. Decompressing Suspension.

- (1) Start engine (para 2-21a or b).
- (2) Raise cab (para 2-22a).

**2-58. PREPARATION FOR INTERNAL AIR TRANSPORT,
HIGHWAY OR RAIL SHIPMENT (CONT)**

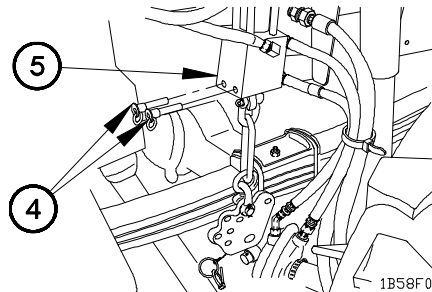
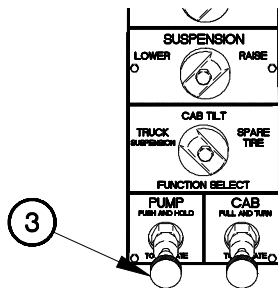
CAUTION

- Ensure area above cab is adequate before raising suspension. Failure to comply may result in damage to equipment.
- Do not operate vehicle off road without both air springs unpinned and deflated. Failure to comply may result in damage to equipment.



1B58F011

- (3) Turn SUSPENSION knob (1) to the LOWER position.
- (4) Turn FUNCTION SELECT knob (2) to the TRUCK SUSPENSION position.



1B58F021

NOTE

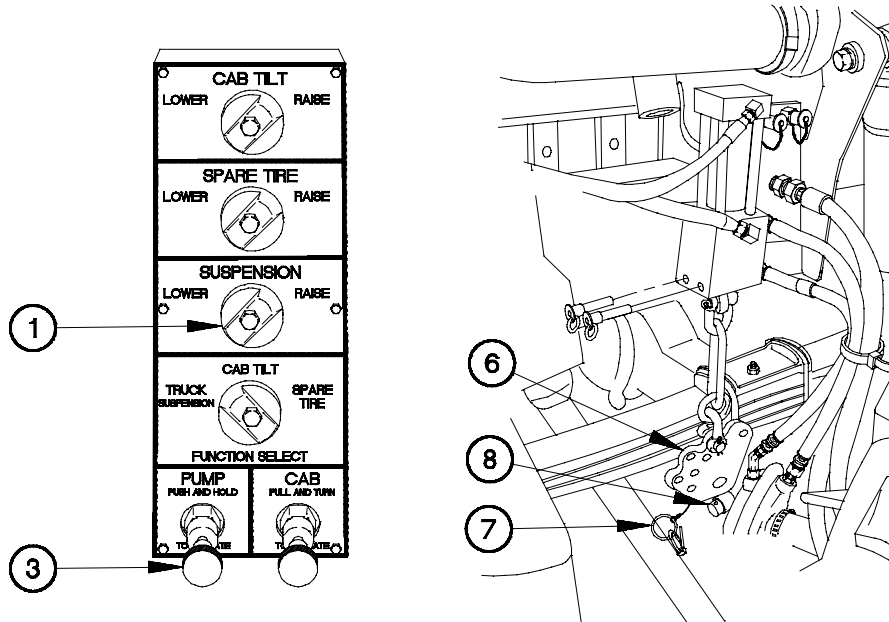
Use back-up hydraulic pump (para 2-41) if pressing PUMP knob does not accomplish step (5).

- (5) Press and hold PUMP knob (3) until two safety pins (4) can be removed from compression cylinder (5).

NOTE

Left and right side safety pins are removed from compression cylinders the same way. Right side safety pins shown.

- (6) Remove two safety pins (4) from compression cylinder (5).



1B58F031

- (7) Turn SUSPENSION knob (1) to the RAISE position.

NOTE

Use back-up hydraulic pump (para 2-41) if pressing PUMP knob does not accomplish step (8).

- (8) Press and hold PUMP knob (3) until vehicle returns to normal height and suspension compression plate (6) is loose.
- (9) Remove pin (7) from axle stud (8).

WARNING

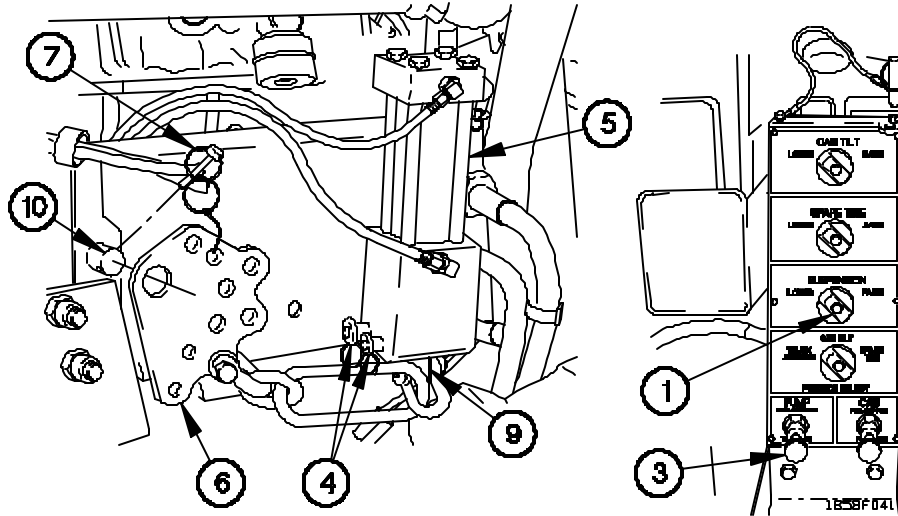
Both suspension compression plates must be installed on axle studs. Failure to comply may result in serious injury or death to personnel.

NOTE

Left and right side suspension compression plates are removed the same way. Right side suspension compression plate shown.

- (10) Remove suspension compression plate (6) from axle stud (8).

**2-58. PREPARATION FOR INTERNAL AIR TRANSPORT,
HIGHWAY OR RAIL SHIPMENT (CONT)**



(11) Turn SUSPENSION knob (1) to the LOWER position.

NOTE

Use back-up hydraulic pump (para 2-41) if pressing PUMP knob does not accomplish step (12).

(12) Press PUMP knob (3) until cylinder rod (9) is fully retracted and two safety pins (4) can be inserted in compression cylinder (5).

NOTE

Left and right side suspension compression plates are installed the same way. Right side suspension compression plate shown.

(13) Install two safety pins (4) in compression cylinder (5).

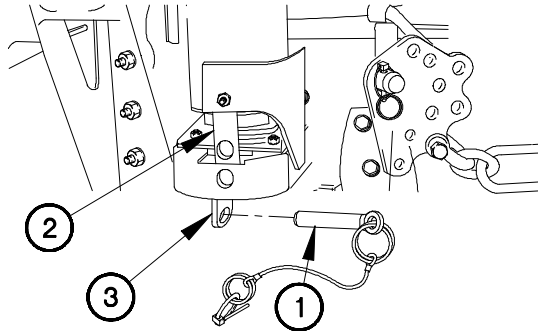
(14) Install suspension compression plate (6) on stud (10).

(15) Install retaining pin (7) in stud (10).

(16) Lower cab (para 2-22b).

(17) Shut down engine (para 2-21f).

g. Cab Air Spring Inflation.



1B58G011

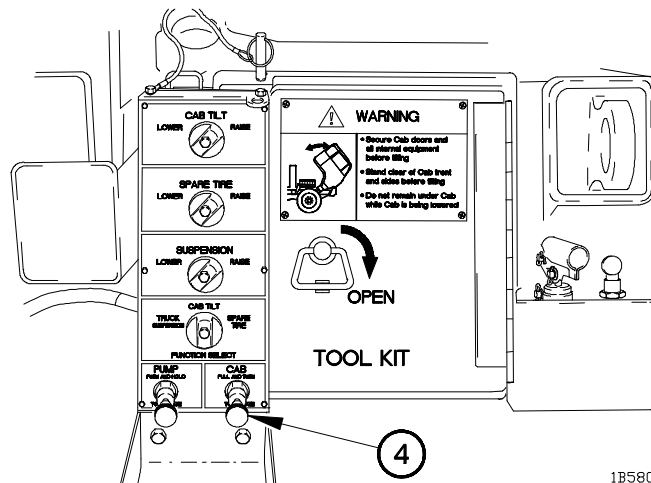
CAUTION

After vehicle is removed from aircraft, both cab air springs must be unpinned and inflated before vehicle is operated. Failure to comply may result in damage to equipment.

NOTE

Left and right side cab air springs are inflated the same way. Right side cab air spring shown.

- (1) Remove quick release pin (1) from air spring (2).
- (2) Install quick release pin (1) in air spring bracket (3).
- (3) Perform steps (1) and (2) on left side of vehicle.

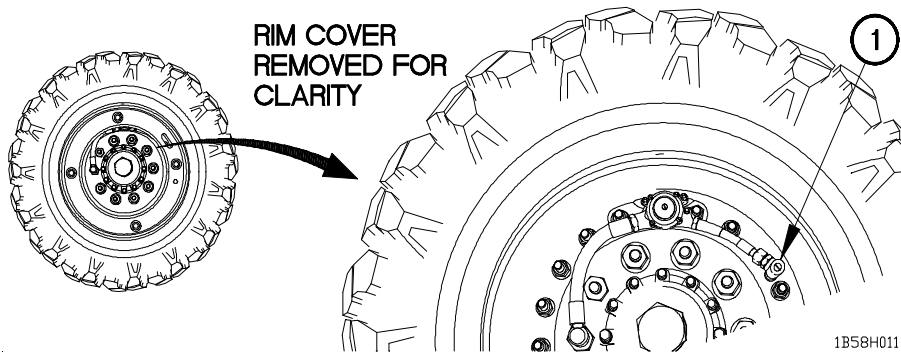


1B58G021

- (3) Press and turn CAB knob (4) to the right.

**2-58. PREPARATION FOR INTERNAL AIR TRANSPORT,
HIGHWAY OR RAIL SHIPMENT (CONT)**

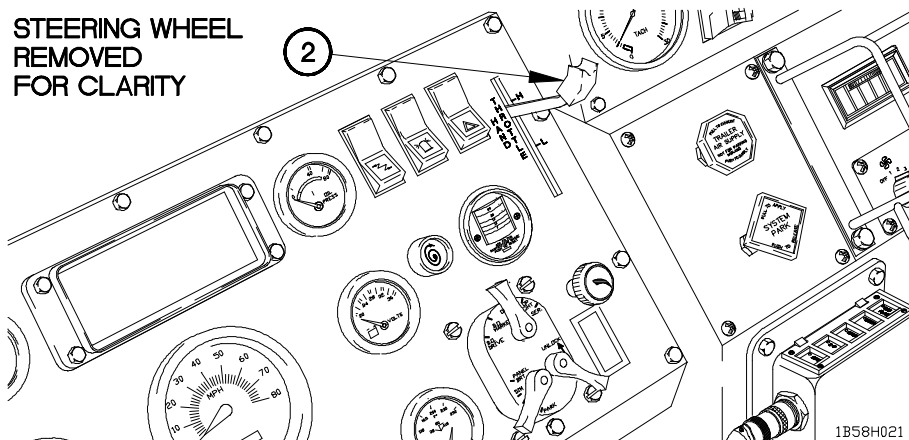
h. Front Tire Inflation.



NOTE

- Drive vehicle clear of aircraft before performing this procedure.
- Left and right front tires are inflated the same way. Left front tire shown.

(1) Turn kneeling valve (1) 1/2 turn to right to fully close valve.

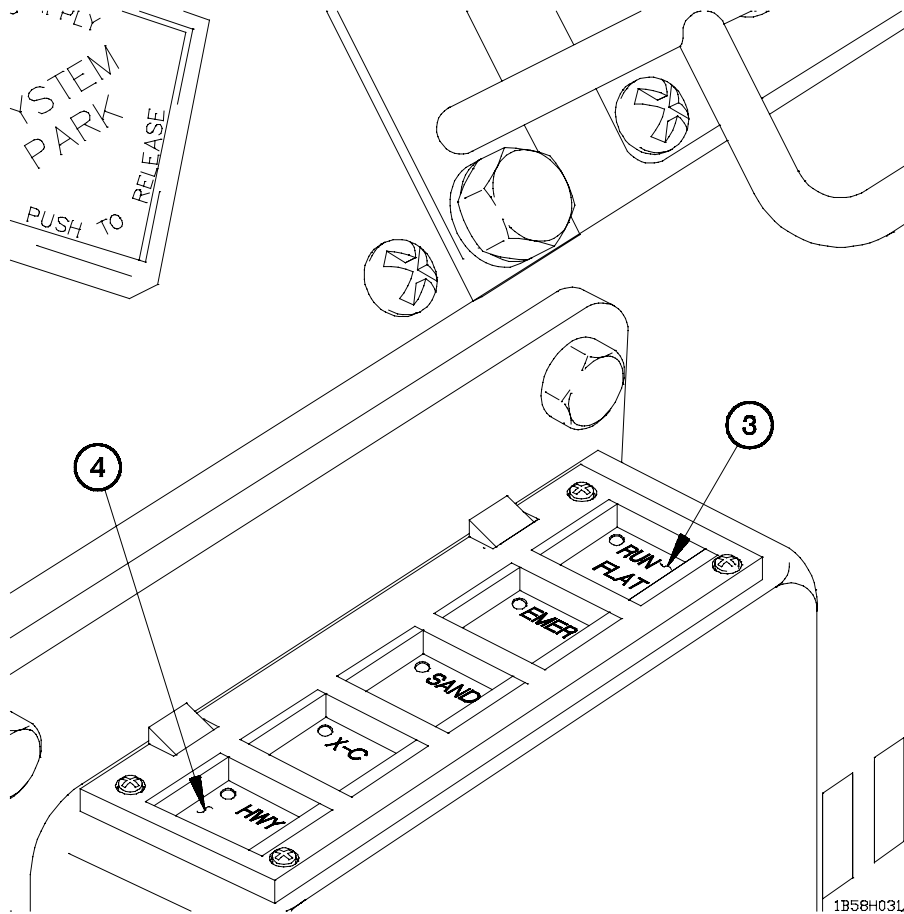


(2) Start engine (para 2-21a or b).

NOTE

In the event of a tachometer failure a HAND THROTTLE lever positioned to H is approximately 2,000-2,200 rpm.

(3) Set engine speed to 2,000-2,200 rpm or place HAND THROTTLE lever (2) to H.



CAUTION

Vehicle may be driven while tires are inflating, but is restricted to first gear and on smooth surfaces. Failure to comply may result in damage to equipment.

NOTE

After one minute of inflation any gear range/speed may be selected and no terrain restriction exists.

- (4) Press RUN FLAT (3) and HIGHWAY (4) modes at same time (para 2-23c).

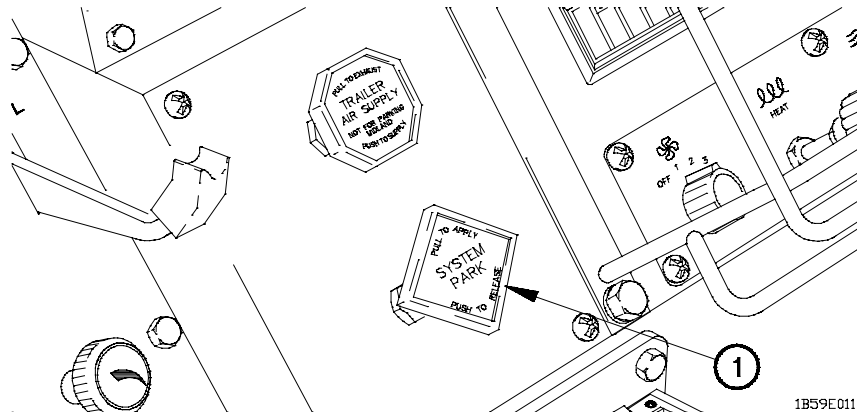
2-59. RAPID ENGINE WARM-UP

WARNING

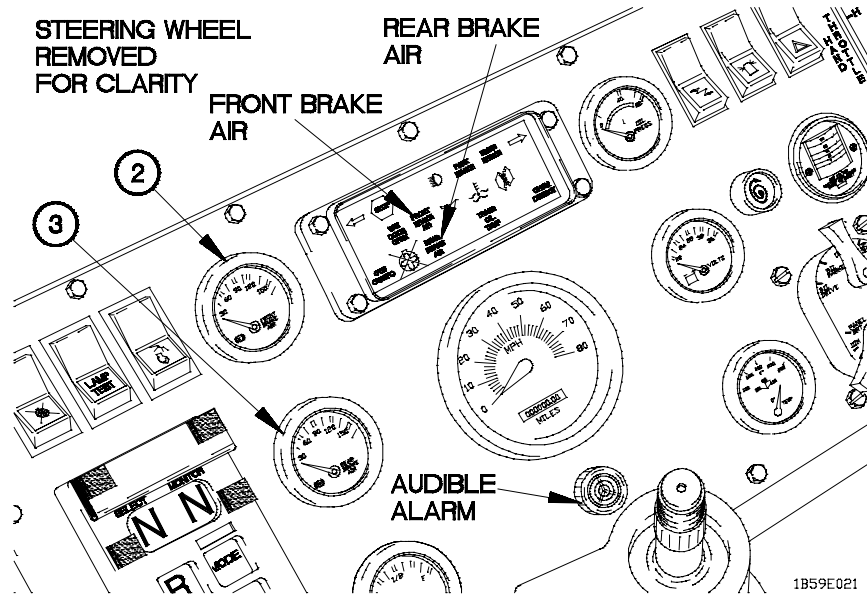
Wear arctic clothing when cab temperatures fall and remain below 30°F (-1°C). Cold stress preventative measures in FM 21-10 should be applied when vehicle cab temperatures fall and remain below 30°F (-1°C). Failure to comply may result in serious injury or death to personnel.

CAUTION

This procedure is intended for use under extreme or unusual conditions, such as heavy windshield frost or when it is difficult to achieve normal operating temperatures. Failure to comply may result in damage to equipment.



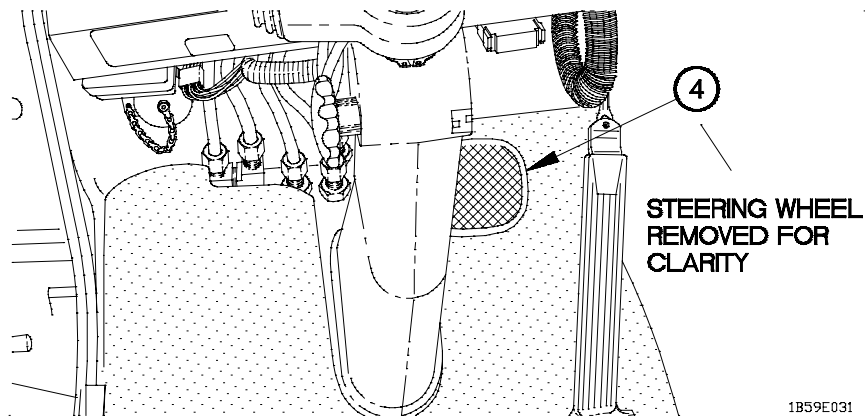
- (1) Install wheel chocks (para 2-21h).
- (2) Pull out SYSTEM PARK control (1).



NOTE

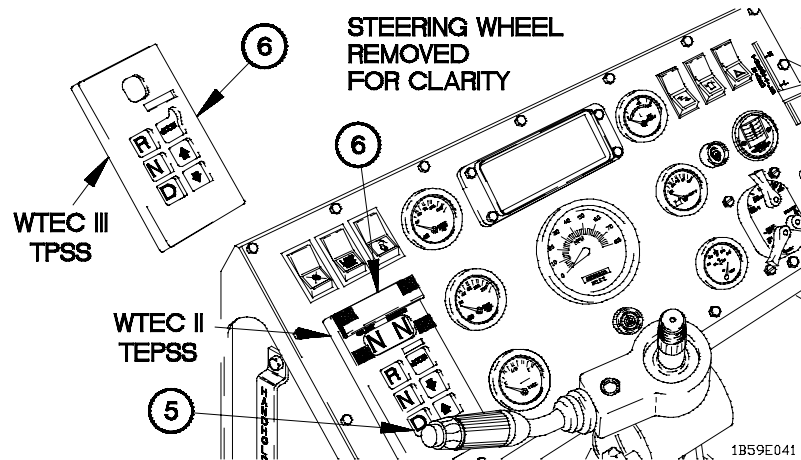
FRONT BRAKE AIR indicator and REAR BRAKE AIR indicator illuminate (red) and audible alarm will sound until FRONT BRAKE AIR and REAR BRAKE AIR pressure gages reach approximately 65 psi (448 kPa).

- (3) Check that FRONT BRAKE AIR pressure gage (2) and REAR BRAKE AIR pressure gage (3) read between 65-120 psi (448-827 kPa).



- (4) Depress brake pedal (4).

2-59. RAPID ENGINE WARM-UP (CONT)



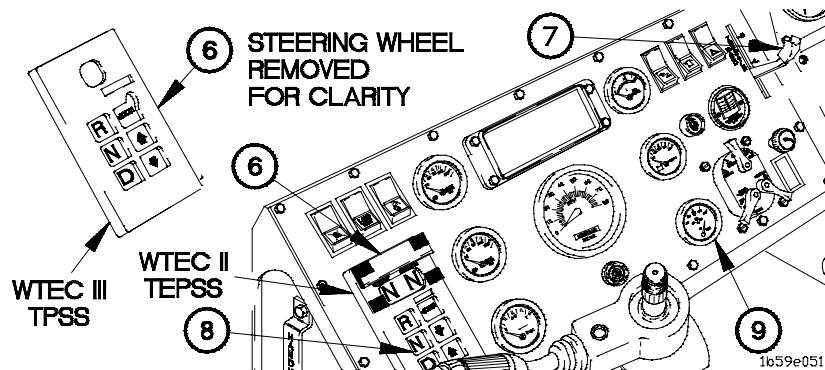
WARNING

- Do not leave vehicle without first returning HAND THROTTLE lever to full down position and placing transmission in Neutral. Failure to comply may result in serious injury or death to personnel.
- Brake pedal must be held down and personnel kept clear of vehicle path while WTEC II Transmission ECU Pushbutton Shift Selector (TEPSS) or WTEC III Transmission Pushbutton Shift Selector (TPSS) is in DRIVE. Transmission will sometimes shift into third gear when in cold operation. Transmission will shift into second when engine reaches operating temperature 165° F (74°C) on WATER TEMP gage) causing the vehicle to lurch or move forward. The vehicle cannot move if SYSTEM PARK is engaged and the brake pedal is held down. Failure to comply may result in serious injury or death to personnel.

CAUTION

If TRANS OIL TEMP indicator illuminates during engine warmup, shut down engine immediately. Failure to comply may result in damage to equipment.

- (5) Select D for DRIVE (5) on WTEC II TEPSS (6) or WTEC III TPSS (6).



CAUTION

Time limits must be followed to prevent overheating. Failure to comply may result in damage to equipment.

NOTE

In the event of a tachometer failure a HAND THROTTLE lever positioned to L is approximately 1,250 to 1,450 rpm.

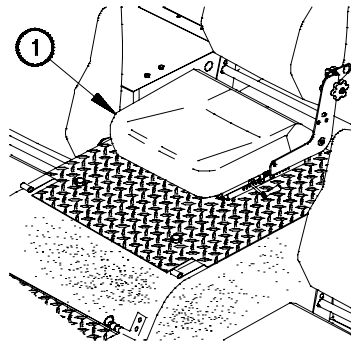
- (6) Set engine speed to 1,250 to 1,450 rpm or place HAND THROTTLE lever (7) to L for two minutes maximum.
- (7) Set engine speed to idle (750 rpm) or place HAND THROTTLE lever (7) to full down position.
- (8) Select N for NEUTRAL (8) on WTEC II TEPSS (6) or WTEC III TPSS (6) and allow engine to idle (750 rpm) for two minutes minimum.

NOTE

- Vehicle performance, including heater/defroster, will be reduced when engine operating temperature is between 100° F to 165° F (38° C to 74° C). Avoid conditions requiring maximum performance until WATER TEMP gage reaches 165° F (74° C).
 - If WATER TEMP gage does not show 165° F (74° C) within 20 minutes, notify Unit Maintenance.
- (9) Repeat steps (5) through (8) until WATER TEMP gage (9) reaches 165° F (74° C) maximum, or 100° F (38° C) minimum to begin driving.

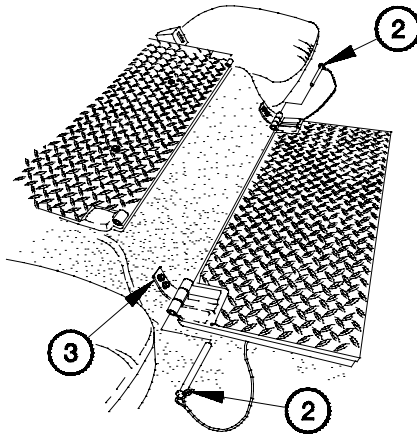
2-60. PREPARATION FOR MACHINE GUN OPERATION

a. Raise Machine Gun Platform.



1B60A01B

(1) Fold center seat (1) up.



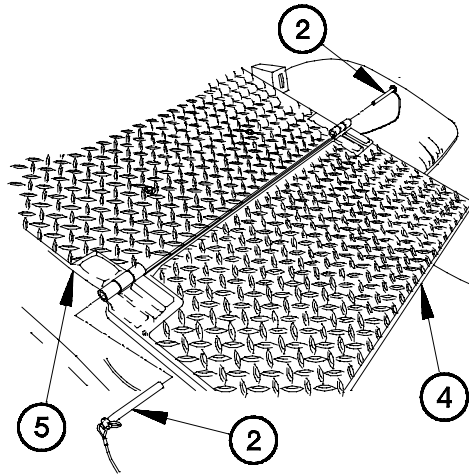
1B60A021

CAUTION

Lower platform must be securely pinned to stowage bracket or upper platform. Failure to comply may result in damage to equipment.

(2) Disconnect two quick release pins (2) from storage brackets (3).

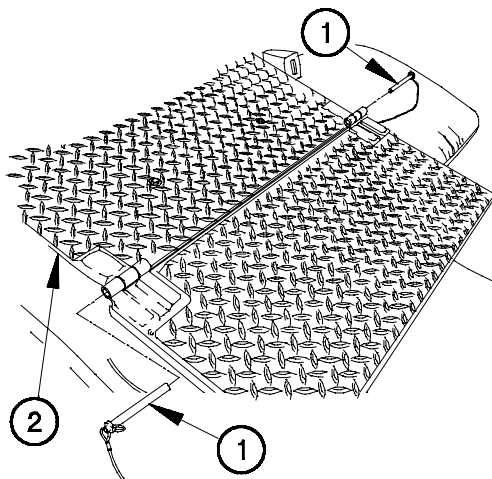
2-60. PREPARATION FOR MACHINE GUN OPERATION (CONT)



1B60A031

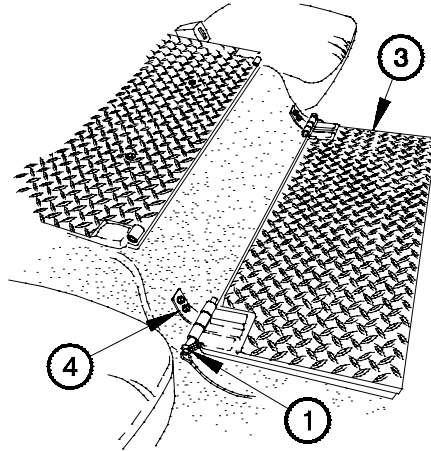
(3) Connect lower platform (4) to upper platform (5) with two quick release pins (2).

b. Stow Machine Gun Ring Platform.



1B60B011

(1) Disconnect two quick release pins (1) from upper platform (2).

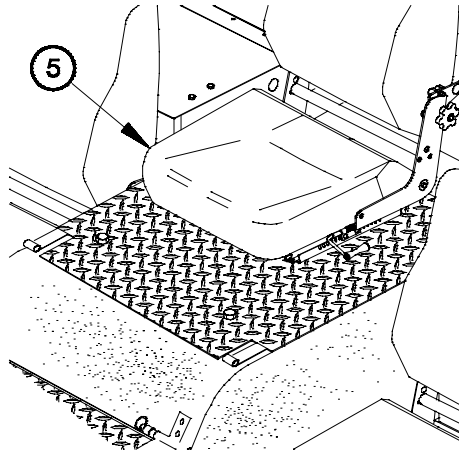


1B60B021

CAUTION

Ensure that quick release pins go completely through lower platform and stowage brackets. Failure to comply may result in damage to equipment.

- (2) Connect lower platform (3) to storage brackets (4) with two quick release pins (1).

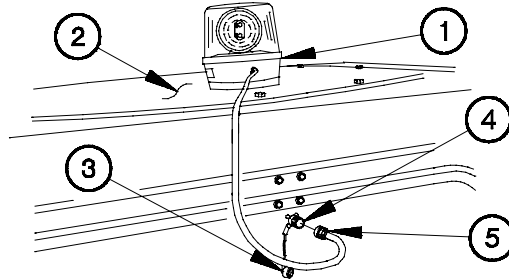


1B60B031

- (3) Fold center seat (5) down. ■

2-61. AMBER WARNING LIGHT KIT INSTALLATION/REMOVAL

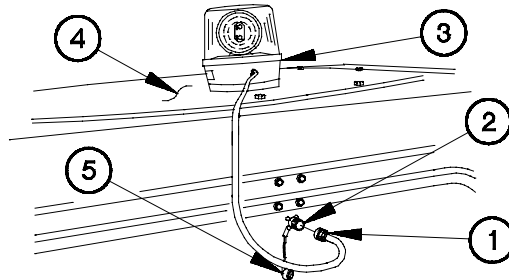
a. Install Amber Warning Light.



1B61A011

- (1) Position amber warning light (1) on cab (2).
- (2) Remove cap (3) from connector (4).
- (3) Connect amber warning light plug (5) to connector (4).

b. Remove Amber Warning Light.



1B61B011

- (1) Disconnect amber warning light plug (1) from connector (2).
- (2) Remove amber warning light (3) from cab (4).
- (3) Install cap (5) on connector (2).

2-62. STARTING ON HILL OPERATION

- (1) Start engine (para 2-21a or b).
- (2) Apply service brakes (para 2-21d).
- (3) Select the desired gear (para 2-21e).
- (4) Increase engine speed and slowly release service brakes.

2-63. TIRE CHAINS INSTALLATION/REMOVAL

a. Rear Axle Tire Chain Installation.

WARNING

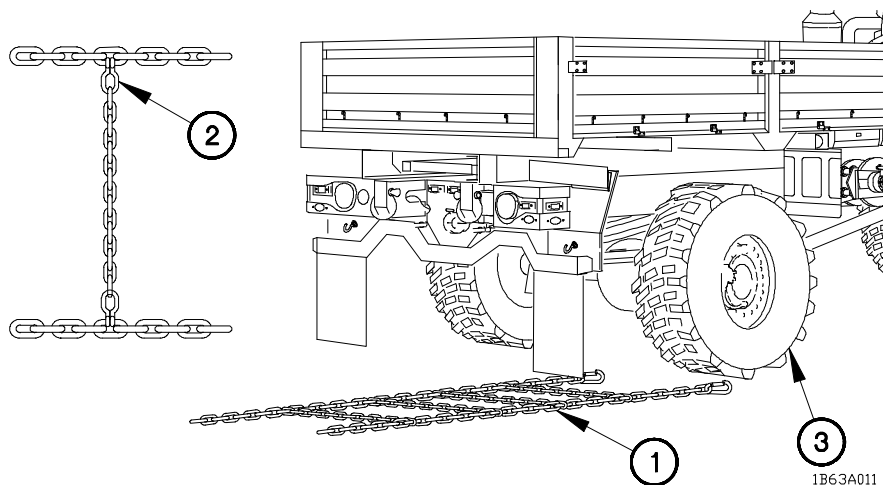
Do not change tire pressure with tire chains installed. Changing tire pressure with tire chains installed could result in chain slippage. Failure to comply may result in serious injury to personnel or damage to equipment.

CAUTION

- When installing tire chains on vehicle rear wheels, ensure CTIS is in HIGHWAY Mode at all times and maximum speed is 10 mph (16 km/h). Failure to comply may result in damage to equipment.
- Tire chains must not be used when driving on hard surfaces where there is no wheel slippage. Failure to comply may result in damage to equipment.

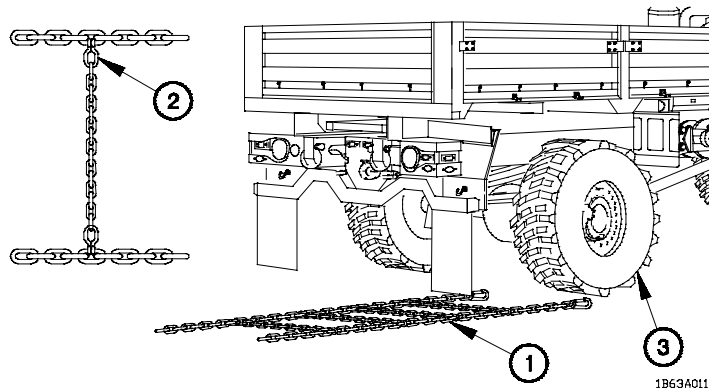
NOTE

Maximum speed limit for vehicles with tire chains on highways is 10 mph (16 km/h). Maximum speed limit for vehicles with tire chains off highway is 15 mph (24 km/h).



- (1) Place tire chain (1) on ground with cross chain connecting links (2) facing down.
- (2) Start engine (para 2-21a or b).

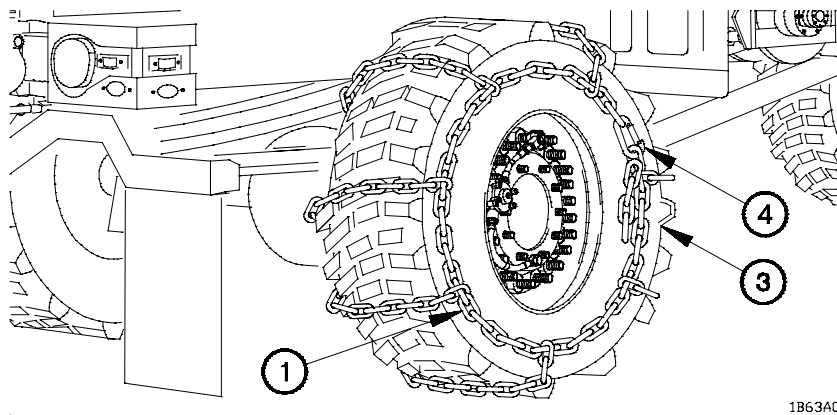
2-63. TIRE CHAINS INSTALLATION/REMOVAL (CONT)



WARNING

Do not back up vehicle without an assistant. Operator has limited vision while backing vehicle. Failure to comply may result in serious injury or death to personnel or damage to equipment.

- (3) Back vehicle onto tire chain (1) so tire (3) is about one-third of the way on tire chain.
- (4) Shut down engine (para 2-21f).



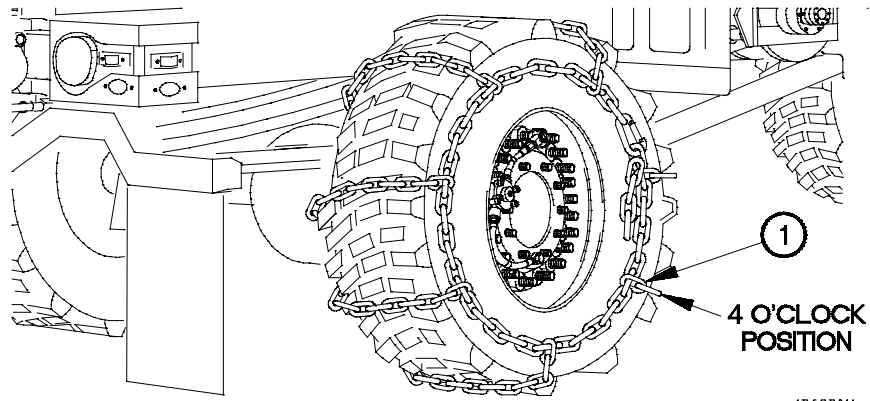
- (5) Wrap tire chain (1) around tire (3).

NOTE

Inside and outside clamps are connected the same way. Outside clamp shown.

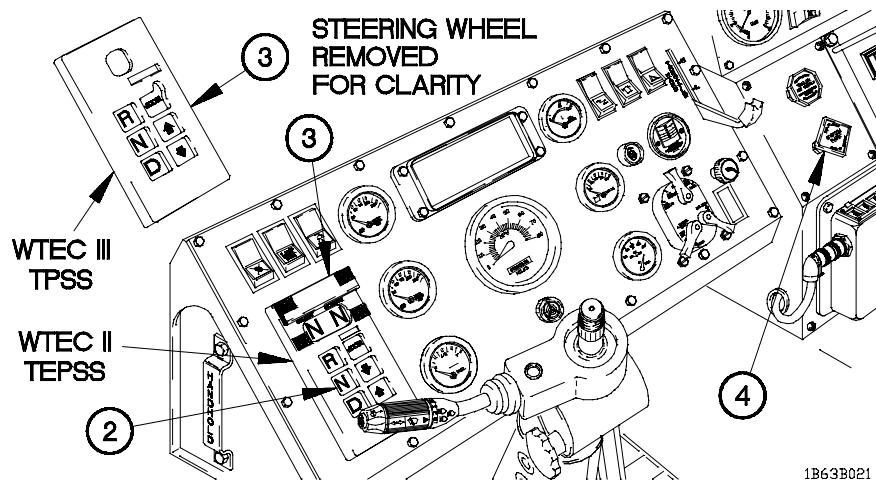
- (6) Connect inside and outside clamps (4) so tire chain (1) is tight around tire (3).

b. Rear Axle Tire Chain Removal.

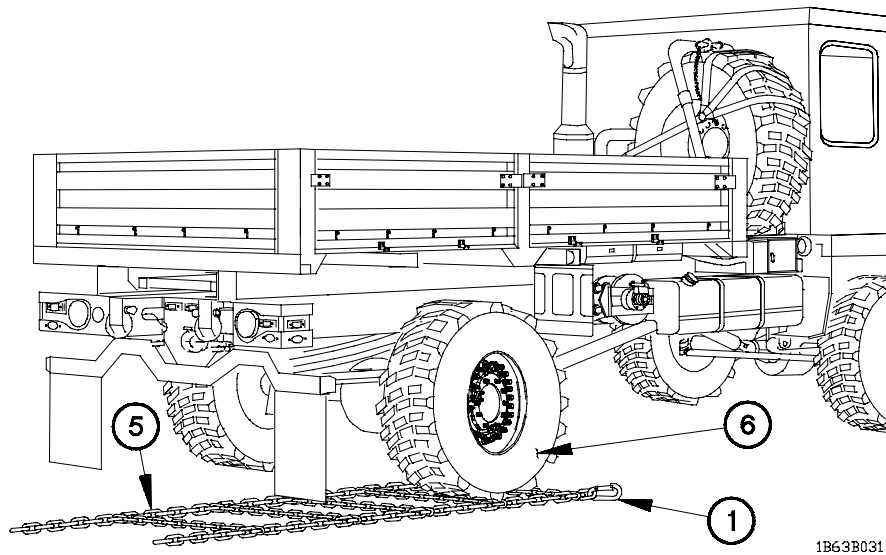


1B63B011

- (1) Start engine (para 2-21a or b).
- (2) Move vehicle until tire chain clamps (1) to be removed are at the 4 o'clock position.

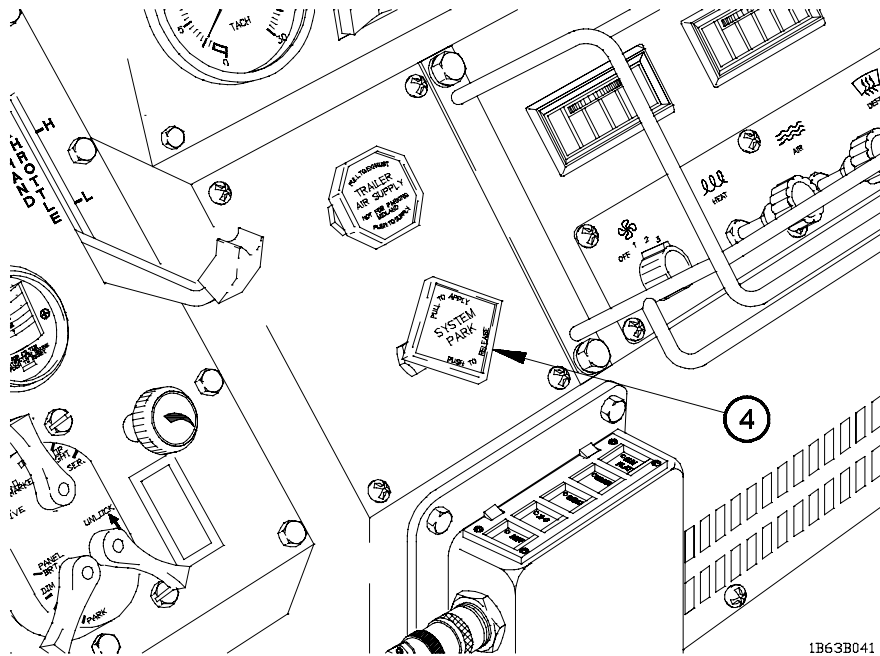


- (3) Press N (Neutral) button (2) on WTEC II TEPSS (3) or WTEC III TPSS (3).
- (4) Pull out SYSTEM PARK control (4).

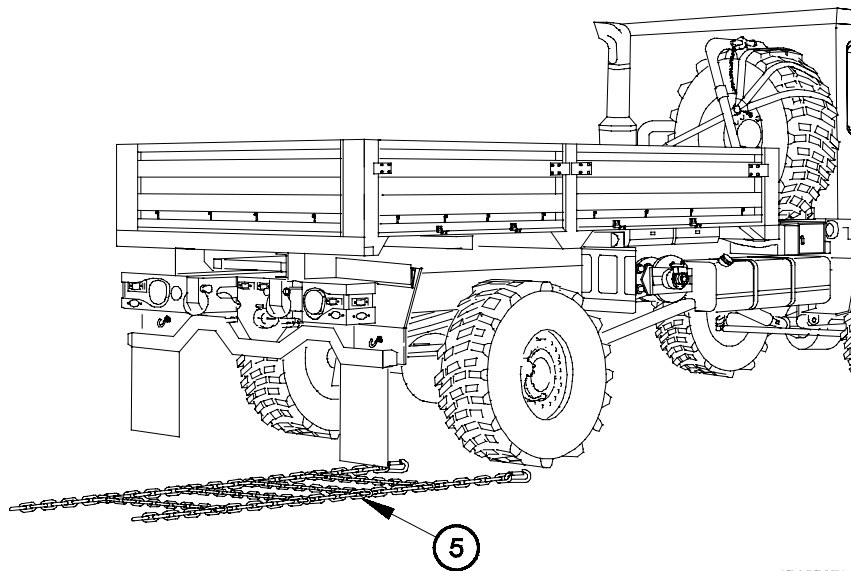


- (5) Disconnect tire chain clamps (1) on tire chain (5).
- (6) Unwrap tire chain (5) from tire (6) and spread tire chain on ground.

2-63. TIRE CHAINS INSTALLATION/REMOVAL (CONT)



(7) Push in SYSTEM PARK control (4).



(8) Drive vehicle forward off tire chain (5).

(9) Shut down engine (para 2-21f).

**2-64. VEHICLE OPERATION IN COLD ENVIRONMENT 32°F TO
-25°F, (0°C TO -32°C)****a. Cold Environment Operations.****WARNING**

Wear arctic clothing when cab temperatures fall and remain below 30° F (-1° C). Cold stress preventative measures in FM 21-10 should be applied when vehicle cab temperatures fall and remain below 30° F (-1° C). Failure to comply may result in serious injury or death to personnel.

CAUTION

- Before operating ensure the vehicle has been prepared for cold weather environment in accordance with FM 9-207. Refer to FM 31-70, FM 31-71, and FM 21-305 for additional information on operation in cold environment. Failure to comply may result in damage to equipment.
- Monitor instrument panel gauges closely. If there are any unusual readings, stop vehicle and shut off engine. Check for cause immediately. Failure to comply may result in damage to equipment.
- Park in shelter when possible. If shelter is not available, park so vehicle does not face into wind. Follow procedures in FM 9-207 to prevent vehicle from freezing in place. Failure to comply may result in damage to equipment.
- Fuel filter should be drained before topping off fuel tank. Keep fuel tank as full as possible during cold weather operations. Moisture will form in fuel tank as it cools. Moisture will freeze and block fuel supply to engine. Failure to comply may result in damage to equipment.
- All snow and ice should be removed from vehicle as soon as possible. Snow and ice may slow or prevent movement of equipment. Failure to comply may result in damage to equipment.
- When operating vehicle in snowy or icy conditions, apply brake pedal momentarily, every few miles. This will ensure that brake linings do not become encrusted with snow or ice. Failure to comply may result in injury to personnel or damage to equipment.

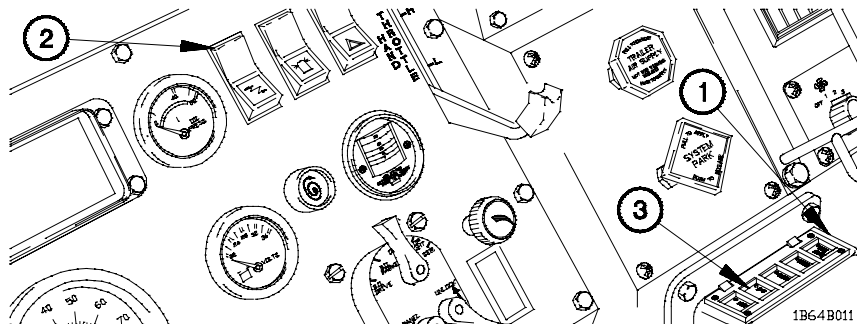
2-64. VEHICLE OPERATION IN COLD ENVIRONMENT, 32°F TO -25°F (0°C TO -32°C) (CONT)

- (1) Notify Unit Maintenance to install cold weather radiator cover.
- (2) Install tire chains, as required (para 2-63).
- (3) Start engine (para 2-21a or b).

b. CTIS Cold Weather Operation.

NOTE

When temperatures are below -15°F (-26°C), CTIS air leaks may occur when the vehicle is started. This is indicated by four or five flashing mode lights on the CTIS ECU. When CTIS seals warm up and air leakage stops, the CTIS ECU should automatically reset and the CTIS ECU selected mode light will light steady. When four or five mode lights are flashing perform step (1).



- (1) Drive vehicle for approximately 15-30 minutes or until CTIS ECU (1) resets.

NOTE

If CTIS ECU does not reset, perform steps (2) through (5). If CTIS ECU does not reset after performing steps (2) through (4), notify Unit Maintenance.

- (2) Position master power switch (2) to off.
- (3) Position master power switch (2) to on.
- (4) Depress cross-country mode (XC) (3) on CTIS ECU (1).

2-65. DELETED

CHAPTER 3 MAINTENANCE INSTRUCTIONS

Section I. LUBRICATION INSTRUCTIONS	3-1
3-1. LUBRICATION	3-1
Section II. TROUBLESHOOTING INSTRUCTIONS	3-2
3-2. INTRODUCTION	3-2
3-3. TROUBLESHOOTING PROCEDURES	3-2
Section III. MAINTENANCE PROCEDURES	3-72
3-4. INTRODUCTION	3-72
3-5. CHANGING TIRE	3-72
3-6. SERVICING TIRES	3-87
3-7. CLEANING VEHICLE	3-92
3-8. OPENING BATTERY BOX/TESTING BATTERIES	3-98
3-9. SERVICING AIR FILTER (EMERGENCY PROCEDURE)	3-102
3-10. M1081 AIR DROP PREPARATION	3-105
3-11. M1081 AIR DROP RECOVERY OPERATIONS	3-126
3-12. TROOPSEAT KIT INSTALLATION/REMOVAL	3-147
3-13. POWER DISTRIBUTION PANEL (PDP) COVER REMOVAL/INSTALLATION	3-156
3-14. REAR SPRING BRAKE CAGING	3-157

Section I. LUBRICATION INSTRUCTIONS

3-1. LUBRICATION

Lubrication instructions are in Appendix F of this TM. All lubrication instructions are mandatory.

Section II. TROUBLESHOOTING INSTRUCTIONS

3-2. INTRODUCTION

Table 3-1 lists common malfunctions you may find with your equipment. Perform the tests, inspections, and corrective actions in the order they appear in the table.

Table 3-1 cannot list all malfunctions that may occur, all tests or inspections needed to find the fault, or all corrective actions needed to correct the fault. If a malfunction is not listed, or actions listed do not correct the fault, notify Unit Maintenance.

3-3. TROUBLESHOOTING PROCEDURES

To quickly find the required troubleshooting procedure, use the Malfunction Index.

Table 3-1. Malfunction Index

<u>Malfunction</u>	<u>Troubleshooting Procedure</u>
a. ENGINE SYSTEM	
a1. Engine Does Not Crank	3-15
a2. Engine Cranks But Does Not Start	3-15
a3. Low Engine Oil Pressure	3-15
a4. Engine Stalls At Low RPM	3-16
a5. Engine Overspeeds On Start	3-16
a6. Too Much Vibration In Engine	3-16
a7. Coolant In Engine Oil	3-17
a8. Excessive Engine Oil Consumption	3-17
a9. Engine Overheats	3-17
a10. Excessive Black Or Gray Exhaust Smoke	3-17
a11. White Exhaust Smoke	3-18
a12. Engine Speed Is Not Stable	3-18

Malfunction

Troubleshooting
Procedure

a. ENGINE SYSTEM (CONT)

- a13. Engine Starts But Misfires, Runs Rough, Or Lacks Power 3-18
- a14. Blue Exhaust Smoke 3-19
- a15. Low Engine Power 3-19

b. FUEL SYSTEM

- b1. Engine Cranks But Does Not Start Or Engine Stalls After Starting 3-20
- b2. Ether Starting Aid Does Not Operate 3-20
- b3. Fuel Consumption Too High 3-21
- b4. Accelerator Pedal Sticks 3-21

c. EXHAUST SYSTEM

- c1. Exhaust System Unusually Noisy Or Vibrates Excessively During Engine Operation 3-21
- c2. Exhaust Fumes In Cab 3-21

d. COOLING SYSTEM

- d1. Engine Overheats 3-22
- d2. Oil In Cooling System 3-23
- d3. Loss Of Coolant 3-23

e. ELECTRICAL SYSTEM

- e1. Engine Does Not Crank 3-27
- e2. 12 VDC And/Or 24 VDC Circuits Do Not Operate 3-28
- e3. 24 VDC Circuits Do Not Operate 3-28
- e4. Deleted.
- e5. Engine Cranks But Does Not Start 3-28
- e6. FUEL Gage Does Not Operate Or Is Inaccurate 3-29

e. ELECTRICAL SYSTEM (CONT)

e7. WATER TEMP Gage Does Not Operate Or Is Inaccurate 3-29

e8. REAR BRAKE AIR PRESSURE Gage Does Not Operate Or Is Inaccurate 3-29

e9. FRONT BRAKE AIR PRESSURE Gage Does Not Operate Or Is Inaccurate 3-30

e10. Engine Oil Pressure Gage Does Not Operate Or Is Inaccurate 3-31

e11. Speedometer Does Not Operate Or Is Inaccurate 3-31

e12. VOLTS Gage Does Not Operate Or Is Inaccurate 3-31

e13. Tachometer Does Not Operate Or Is Inaccurate 3-32

e14. Single Tone Audible Alarm Does Not Operate (All Models Except M1078/M1081) 3-32

e14a. Troop Transport Audible Alarm Does Not Operate 3-32.1

e14b. Master Power Switch Does Not Shut Down Engine 3-32.1

e15. Lamp Test Switch Does Not Illuminate 3-32.1

e16. Radiator Fan OFF Switch Does Not Illuminate 3-33

e16a. Ether Start Switch Does Not Operate 3-33

e16b. Hazard Lights Switch Does Not Illuminate 3-33

e16c. Amber Warning Light Switch Does Not Illuminate 3-34

e16d. Master Power Switch Does Not Illuminate 3-34

e17. Rear Brake Air Gage Does Not Illuminate 3-34

e17a. Fuel Gage Does Not Illuminate 3-35

e17b. Front Brake Air Gage Does Not Illuminate 3-35

e17c. Speedometer Does Not Illuminate 3-35

Malfunction

e. ELECTRICAL SYSTEM (CONT)

e17d. VOLTS Gage Does Not Illuminate 3-36

e17e. WATER TEMP Gage Does Not Illuminate 3-36

e17f. OIL PRESS Gage Does Not Illuminate 3-37

e18. Auxiliary Panel, Personnel Heater, And
Instrument Panel Do Not Illuminate 3-37

e19. Tachometer Does Not Illuminate 3-38

e20. Auxiliary Panel Switch Does Not Illuminate 3-38

e21. Auxiliary Panel Does Not Illuminate 3-38

e22. High Engine Temperature Indicator Does Not Illuminate 3-38.1

e22a. High Engine Temperature Indicator Illuminates 3-38.1

e23. Central Tire Inflation System (CTIS) Overspeed Indicator
Does Not Illuminate 3-38.1

e24. Chemical Detector Indicator Does Not Illuminate 3-39

e25. Left Turn Signal Indicator Does Not Illuminate 3-40

e26. Right Turn Signal Indicator Does Not Illuminate 3-40

e27. Turn Signal Indicators And High Beams On Indicator
Do Not Illuminate 3-41

e28. High Beams On Indicator Does Not Illuminate 3-41

e29. Parking Brake Indicator And/Or Emergency Brake Indicator
Does Not Illuminate 3-41

e30. Power Take-Off (PTO) Indicator Does Not Illuminate 3-41

e31. Fan Off Indicator Does Not Illuminate 3-42

e32. Transmission Temperature Indicator Does Not Illuminate 3-42

<u>Malfunction</u>	<u>Troubleshooting Procedure</u>
e. ELECTRICAL SYSTEM (CONT)	
e33. Front Brake Air Indicator Does Not Illuminate When Air Pressure Is Below 65 PSI	3-43
e34. Rear Brake Air Indicator Does Not Illuminate When Air Pressure Is Below 65 PSI	3-43
e35. Engine Oil Pressure Indicator Does Not Illuminate	3-44
e36. Master Stop Indicator Does Not Illuminate	3-44
e37. One Or Both Headlights (High And Low Beam) Do Not Illuminate	3-44
e38. One Or Both Headlight Low Beams Do Not Illuminate	3-45
e39. One Or Both Headlight High Beams Do Not Illuminate	3-45
e40. Parking Lights Do Not Illuminate	3-45
e41. LH Door And/Or LH Front Marker Lights Do Not Illuminate	3-45
e42. RH Door And/Or RH Front Marker Lights Do Not Illuminate	3-46
e43. One Or More Cab Top Marker Lights Do Not Illuminate	3-46
e44. Side And/Or Rear Marker Light(s) Do Not Illuminate	3-46
e44a. All Marker Lights Do Not Operate In Normal Mode	3-46
e45. One Or Both Composite Taillights Do Not Illuminate	3-46
e46. One Or Both Front Blackout Marker Lights Do Not Illuminate	3-47
e47. Blackout Drive Light Does Not Illuminate	3-47
e48. One Or Both Rear Blackout Marker Lights Do Not Illuminate	3-48
e49. Warning Light Does Not Illuminate	3-48
e50. Backup Light Does Not Illuminate	3-49
e51. Blackout Marker Lights Do Not Illuminate	3-49
e51a. Front Hazard Lights Do Not Illuminate	3-50

Malfunction

Troubleshooting
Procedure

e. ELECTRICAL SYSTEM (CONT)

e52. Rear Hazard Lights Do Not Illuminate 3-50

e53. Front And Rear Hazard Lights Do Not Illuminate 3-50

e54. Front And Rear Turn Signals Do Not Illuminate 3-51

e55. Left Or Right Front Turn Signal Does Not Illuminate 3-52

e56. One Or Both Stoplights Do Not Illuminate 3-52

e57. One Or Both Blackout Stoplights Do Not Illuminate 3-52

e58. Stoplights And Blackout Stoplights Do Not Illuminate 3-53

e59. Trailer Marker/Taillights Do Not Illuminate 3-53

e60. Trailer Right Stop/Turn Light Does Not Illuminate 3-53

e61. Trailer Left Stop/Turn Light Does Not Illuminate 3-53

e62. Trailer Blackout Marker Lights Do Not Illuminate 3-54

e63. Trailer Blackout Stoplights Do Not Illuminate 3-54

e64. Intervehicle Clearance Lights Do Not Illuminate 3-54

e65. Intervehicle Left Turn Signal Does Not Illuminate 3-54

e66. Intervehicle Right Turn Signal Does Not Illuminate 3-54

e67. Intervehicle Stoplights Do Not Illuminate 3-54

e68. Intervehicle Taillights Do Not Illuminate 3-54

e69. Personnel Heater Control Illumination Does Not Operate 3-54

e70. Personnel Heater Fan Does Not Operate 3-55

e71. Windshield Washer Does Not Operate 3-55

e72. Windshield Wiper Does Not Operate On Low Speed 3-55

<u>Malfunction</u>	<u>Troubleshooting Procedure</u>
e. ELECTRICAL SYSTEM (CONT)	
e73. All Windshield Wiper Speeds Do Not Operate	3-56
e74. Windshield Wiper Does Not Operate On Intermittent Speed	3-56
e75. Windshield Wiper Does Not Operate On High Speed	3-57
e76. Horn does not operate	3-57
e77. Chemical Alarm Does Not Operate	3-57
e78. Chemical Detector Does Not Operate	3-58
e79. Central Tire Inflation System (CTIS) Does Not Operate	3-58
e80. Central Tire Inflation System (CTIS) Does Not Inflate Tires	3-58
e81. Central Tire Inflation System (CTIS) Does Not Deflate Tires	3-59
e82. 11K Self-Recovery Winch (SRW) Does Not Reel In Or Pay Out	3-59
e83. 11K Self-Recovery Winch (SRW) Does Not Reel In	3-60
e84. 11K Self-Recovery Winch (SRW) Does Not Pay Out	3-60
e85. Power Take-Off (PTO) Does Not Operate	3-61
e86. Electrical System Does Not Maintain A Charge	3-61
e87. WTEC II Transmission ECU Pushbutton Shift Selector (TEPSS) Illumination Does Not Dim	3-62
e88. Engine Fan Runs Constantly	3-62
e89. Engine Fan Does Not Turn Off Using Radiator Fan Off Switch	3-63
e90. Ether Start Does Not Operate	3-63
e91. Excessive Condensation In Fuel	3-63
e92. Radio Does Not Operate	3-64
e93. Start Inhibit Pushbutton Switch Does Not Operate	3-64

Malfunction

e. ELECTRICAL SYSTEM (CONT)

e94. Air Dryer Does Not Operate..... 3-64

e95. Battery Tester Does Not Operate 3-64

e96. M1079 Fan Does Not Operate 3-64

e97. All M1079 Van Body Marker Lights Do Not Illuminate 3-65

e98. M1079 Van Body Marker Light Does Not Illuminate 3-65

e99. All M1079 Fluorescent Lights Do Not Illuminate..... 3-65

e100. M1079 Fluorescent Light(s) DS80 And/Or DS81 Do Not
Illuminate..... 3-65

e101. M1079 Fluorescent Light(s) DS82 And/Or DS83 Do Not
Illuminate..... 3-65

e102. M1079 110 VAC Outlet J233 Does Not Operate 3-65

e103. M1079 110 VAC Outlet J234 Does Not Operate 3-65

e104. M1079 110 VAC Outlet J235 Does Not Operate 3-66

e105. M1079 110 VAC Outlet J232 Does Not Operate In Normal Mode..... 3-66

e106. M1079 110 VAC Outlet J232 And J233 Do Not Operate
In Blackout Override Mode 3-66

e107. M1079 110 VAC Outlet J231 Does Not Operate 3-66

e108. M1079 110 VAC Outlet J230 Does Not Operate 3-66.1

e109. M1079 Blackout Light(s) Does Not Illuminate 3-66.1

e110. One Or More M0179 Emergency Light(s) Do Not Illuminate 3-66.1

e111. M1079 Field Phone 1 And/Or 2 Binding Post Does Not Operate 3-67

e112. M1079 Air Conditioner Does Not Operate..... 3-67

e113. M1079 Heater Does Not Operate 3-68

e. ELECTRICAL SYSTEM (CONT)

e114. M1079 24 VDC Binding Post(s) Does Not Operate 3-68

e115. M1079 Van Door Open Light Does Not Illuminate And Audible Alarm Does Not Operate 3-68

e116. M1079 110 VAC Power Does Not Operate 3-68

e117. M1079 Fluorescent Lights Do Not Illuminate In Blackout Override Mode 3-68

f. TRANSMISSION SYSTEM

f1. WTEC II Transmission ECU Pushbutton Shift Selector (TEPSS) Emits Eight Seconds Of Beeps And/Or Transmission Does Not Shift Gears 3-68

f1a. WTEC II Transmission ECU Pushbutton Shift Selector (TEPSS) Does Not Illuminate 3-68 1

f2. Transmission Unusually Noisy When Operating 3-68.2

f3. WTEC III Transmission Pushbutton Shift Selector (TPSS) Displays "--" And/Or Transmission Does Not Shift Gears 3-68.3

f4. WTEC III Transmission Pushbutton Shift Selector (TPSS) Does Not Illuminate 3-68.4

g. PROPELLER SHAFT

g1. Propeller Shafts Or Universal Joints Unusually Noisy When Operating 3-69

h. POWER TAKE-OFF (PTO)

h1. Power Take-Off (PTO) Does Not Engage 3-69

i. BRAKE SYSTEM

i1. Excessive Braking Distance 3-69

Malfunction

i. BRAKE SYSTEM (CONT)

i2.	Rear Brakes Do Not Apply	3-69
i3.	Parking Brake(s) Will Not Release	3-70
i4.	Front Brakes Overheat And/Or Do Not Release	3-70
i5.	Vehicle Brakes Unevenly, Brakes Pull To One Side Or Grab	3-70.2
i6.	Front Brakes Do Not Apply.....	3-70.2
i7.	Rear Brakes Overheat	3-70.2
i8.	Parking Brakes Do Not Apply	3-70.2
i9.	Brake System Loses Air When Service Brakes Are Applied	3-70.2

j. AIR SYSTEM

j1.	Air System Loses Pressure During Operation/Slow, No, Or Incorrect Air Pressure Buildup	3-70.3
j2.	Large Quantity Of Moisture Expelled From Air Reservoirs	3-70.3
j3.	Air Dryer Purges Continually.....	3-70.3
j4.	No Air Pressure Present At Rear Gladhand(s).....	3-70.3
j5.	Air System Pressure Builds Up More Than 120 psi (827 kPa) (Compressor Fails To Unload).....	3-70.3
j6.	Noisy Air Compressor Operation	3-70.3

k. WHEEL

k1.	Tires Wear Unevenly Or Excessively	3-70.4
k2.	Wheel Wobbles Or Shimmies	3-70.4

I. HYDRAULIC SYSTEM

I1.	Loss Of Hydraulic Pressure (Single Stage Pump).....	3-70.5
-----	---	--------

<u>Malfunction</u>	<u>Troubleshooting Procedure</u>
m. CENTRAL TIRE INFLATION SYSTEM (CTIS)	
m1. Two Steady Mode Lights Illuminate On Central Tire Inflation System (CTIS) ECU	3-70.5
m2. Four Central Tire Inflation System (CTIS) ECU Indicator Lights Flashing	3-70.5
m3. Five Central Tire Inflation System (CTIS) ECU Indicator Lights Flashing	3-70.5
m4. Central Tire Inflation System (CTIS) Repeatedly Resumes Cycling 30 Seconds After Indicator Lights Stop Flashing	3-70.5
m5. Central Tire Inflation System (CTIS) ECU Indicates No Fault Code But System Fails To Inflate Or Deflate	3-70.5
m6. No Overspeed Warning Light And/Or Overspeed Pressure Change	3-70.6
n. AXLE	
n1. Axle Differential(s) Noisy	3-70.6
p. STEERING SYSTEM	
p1. Hard To Steer	3-70.6
p2. Wanders, Pulls To One Side, Or Shimmies	3-70.7
p3. Excessive Play When Turning Steering Wheel	3-70.8
p4. No Response When Turning Steering Wheel	3-70.8
q. SUSPENSION SYSTEM	
q1. Wanders, Pulls To One Side, Or Shimmies	3-70.8
q2. Leans To One Side, Or Rear Of Vehicle Sags	3-70.8
r. 11K SELF-RECOVERY WINCH (SRW) SYSTEM	
r1. 11K Self-Recovery Winch (SRW) Does Not Operate	3-70.9

Malfunction

s. STEERING HYDRAULIC SYSTEM

- s1. Steering Hard Or Does Not Operate 3-70.10

t. AIR TRANSPORT SYSTEM

- t1. Cab Tilt, Spare Tire Retainer, And Suspension Compression Do Not Operate 3-70.10
- t2. Suspension Does Not Compress Or Return To Normal Properly 3-70.10
- t3. Cab Leveling Air Springs Do Not Operate Properly 3-70.11

u. SPECIAL PURPOSE KIT

- u1. No Power to Digitization Rack 3-70.11
- u2. No Power to Mobile Tracking System (MTS) Sense 3-70.11
- u3. No Power to Enhanced Position Location Reporting System (EPLRS) 3-70.13
- u4. No Power to Precision Lightweight Global Positioning System Receiver (PLGR) 3-70.14
- u5. No Power to Driver Visual Enhancement (DVE) 3-70.15
- u6. No Power to SINGGAR/ Force XXI Battle Command Brigade and Below (FBCB) 3-70.17
- u7. No Power to Mobile Tracking System (MTS) 3-70.18
- u8. Deleted
- u9. Deleted
- u10. Deleted
- u11. Deleted
- u12. Deleted
- u13. Deleted
- u14. Deleted
- u15. Deleted

Malfunction

u. SPECIAL PURPOSE KIT (CONT)

- u16. Deleted
- u17. Troop Transport Alarm Does Not Operate 3-70.12
- u18. Light Material Handling Crane (LMHC) Does Not Operate 3-70.20
- u19. Light Material Handling Crane (LMHC) Hoist IN Does Not Operate 3-70.20
- u20. Light Material Handling Crane (LMHC) Hoist OUT Does
Not Operate 3-70.20

v. CAB TILT AND SPARE TIRE RETAINER

- v1. Cab Does Not Raise 3-70.20
- v2. Cab Does Not Lower 3-70.20
- v3. Spare Tire Retainer Does Not Raise 3-70.20
- v4. Spare Tire Retainer Does Not Lower 3-71

w. FRAME TROUBLESHOOTING

- w1. Tires Continue To Wear After Front End Alignment And/Or Vehicle
Drives Sideways Down Road 3-71

Table 3-2. Troubleshooting

MALFUNCTION TEST OR INSPECTION CORRECTIVE ACTION
<p>NOTE</p> <p>If corrective action does not correct malfunction, notify Unit Maintenance.</p> <p>a. ENGINE SYSTEM</p> <p>a1. ENGINE DOES NOT CRANK.</p> <p>Step 1. Check to see if battery cables and terminal posts are OK.</p> <p>(a) Remove battery box cover (para 3-8a).</p> <p>(b) Check battery cables for damage and corrosion.</p> <p style="padding-left: 40px;">If corrosion is present or battery cables are damaged, notify Unit Maintenance.</p> <p>(c) Check terminal posts for corrosion.</p> <p style="padding-left: 40px;">If corrosion is present, notify Unit Maintenance.</p> <p>Step 2. Check fluid level in battery cells (para 3-8b).</p> <p style="padding-left: 40px;">If fluid level is low, notify Unit Maintenance.</p> <p style="padding-left: 40px;">If fluid level is not low, notify Unit Maintenance.</p> <p>(a) Install battery box cover (para 3-8c).</p> <p>a2. ENGINE CRANKS BUT DOES NOT START.</p> <p>Step 1. Check fuel level.</p> <p>(a) Position master power switch to on (para 2-1a).</p> <p style="padding-left: 40px;">If fuel gage shows fuel level at or below E (empty), fuel vehicle (para 2-20a).</p> <p>(b) Position master power switch to off (para 2-1a).</p> <p>Step 2. Is fuel/water separator primed?</p> <p>(a) Raise cab (2-22a).</p> <p>(b) Depress button on fuel/water separator as many times as necessary until button is tight.</p> <p>(c) Attempt to start engine (para 2-21a or b).</p> <p style="padding-left: 40px;">If engine cranks but does not start, notify Unit Maintenance.</p> <p>(d) Lower cab (para 2-22b).</p> <p>a3. LOW ENGINE OIL PRESSURE.</p> <p>Step 1. Check for proper engine oil level.</p> <p>(a) Raise cab (para 2-22a).</p>

Table 3-2. Troubleshooting (Cont)

MALFUNCTION
TEST OR INSPECTION
CORRECTIVE ACTION
a. ENGINE SYSTEM (CONT)
<p>a3. LOW ENGINE OIL PRESSURE (CONT).</p> <ul style="list-style-type: none"> (b) Check engine oil level (para 2-15, item 34). (c) If engine oil level is low, add engine oil (Appendix F). <p>Step 2. Check engine oil for contamination.</p> <ul style="list-style-type: none"> (a) If engine oil is contaminated, notify Unit Maintenance. (b) Lower cab (para 2-22b). (c) If engine oil pressure is still low, notify Unit Maintenance. <p>a4. ENGINE STALLS AT LOW RPM.</p> <p>Step 1. Check for restricted air filter (para 2-21a or b).</p> <ul style="list-style-type: none"> (a) If restricted, clean air filter element (para 3-9). (b) If air filter element will not clean, notify Unit Maintenance. <p>Step 2. Check air cleaner hoses and pipe for kinks and damage.</p> <ul style="list-style-type: none"> (a) Check air particle restriction hose for kinks and damage. (b) Raise cab (para 2-22a). (c) Check air cleaner to turbocharger pipe and hose for kinks or damage. (d) If pipe or hose(s) are damaged or kinked, notify Unit Maintenance. (e) Lower cab (para 2-22b). (f) If engine stalls at low rpm, notify Unit Maintenance. <p>a5. ENGINE OVERSPEEDS ON START.</p> <p>Notify Unit Maintenance.</p> <p>a6. TOO MUCH VIBRATION IN ENGINE.</p> <p>Step 1. Check for restricted air filter (para 2-21a or b).</p> <ul style="list-style-type: none"> (a) If restricted, clean air filter element (para 3-9). (b) If air filter element will not clean, notify Unit Maintenance. <p>Step 2. Check for loose vibration damper and/or missing bolts and damage.</p> <ul style="list-style-type: none"> (a) Raise cab (para 2-22a). (b) Visually check vibration damper for loose and/or missing bolts and damage. (c) If vibration damper bolts are loose or missing or vibration damper is damaged, notify Unit Maintenance.

Table 3-2. Troubleshooting (Cont)

MALFUNCTION
TEST OR INSPECTION
CORRECTIVE ACTION
<p>a6. TOO MUCH VIBRATION IN ENGINE (CONT).</p>
<p>(d) Lower cab (para 2-22b).</p>
<p>(e) If engine still vibrates too much, notify Unit Maintenance.</p>
<p>a7. COOLANT IN ENGINE LUBRICATION OIL.</p>
<p>Notify Unit Maintenance.</p>
<p>a8. EXCESSIVE ENGINE OIL CONSUMPTION.</p>
<p>Step 1. Check for proper engine oil level.</p>
<p>(a) Raise cab (para 2-22a).</p>
<p>(b) Check engine oil level (para 2-15, item 34).</p>
<p>(c) If engine oil level is low, add engine oil (Appendix F).</p>
<p>(d) If engine oil level is high, notify Unit Maintenance.</p>
<p>Step 2. Check for Class II and Class III oil leaks.</p>
<p>(a) Visually check oil lines, engine block, and oil filter for Class II and Class III oil leaks.</p>
<p>(b) If Class II and/or Class III oil leaks are found, notify Unit Maintenance.</p>
<p>(c) Lower cab (para 2-22b).</p>
<p>(d) If oil consumption is still excessive, notify Unit Maintenance.</p>
<p>a9. ENGINE OVERHEATS.</p>
<p>Perform Cooling System Troubleshooting (d1. Engine Overheats).</p>
<p>a10. EXCESSIVE BLACK OR GRAY EXHAUST SMOKE.</p>
<p>Step 1. Check for restricted air filter (para 2-21a or b).</p>
<p>(a) If restricted, clean air filter element (para 3-9).</p>
<p>(b) If air filter element will not clean, notify Unit Maintenance.</p>
<p>Step 2. Check air cleaner hoses and pipe for kinks and damage.</p>
<p>(a) Check air particle restriction hose for kinks and damage.</p>
<p>(b) Raise cab (para 2-22a).</p>
<p>(c) Check air cleaner to turbocharger pipe and hose for kinks or damage.</p>
<p>(d) If pipe or hose(s) is damaged or kinked, notify unit Maintenance.</p>
<p>(e) Lower cab (para 2-22b).</p>
<p>(f) If excessive black or gray smoke is still seen from engine, notify Unit Maintenance.</p>

Table 3-2. Troubleshooting (Cont)

**MALFUNCTION
TEST OR INSPECTION
CORRECTIVE ACTION**

a. ENGINE SYSTEM (CONT)

a11. WHITE EXHAUST SMOKE.

Check for restricted air filter (para 2-21a or b).

- (a) If restricted, clean air filter element (para 3-9).
- (b) If air filter element will not clean, notify Unit Maintenance.
- (c) If white exhaust smoke is still seen from engine, notify Unit Maintenance.

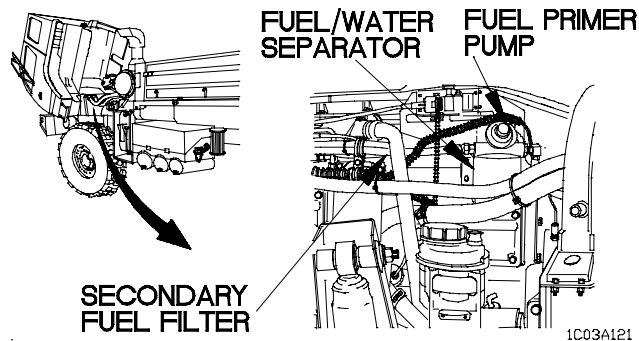
a12. ENGINE SPEED IS NOT STABLE.

Step 1. Check for restricted air filter (para 2-21a or b).

- (a) If restricted, clean air filter element (para 3-9).
- (b) If air filter element will not clean, notify Unit Maintenance.

Step 2. Check for fuel leaks.

- (a) Raise cab (para 2-22a).



- (b) Check secondary fuel filter, fuel lines, fuel fittings, draincocks, fuel tank lines and tank, and other lines that hold fuel for leaks.
- (c) If any fuel leaks are found, notify Unit Maintenance.
- (d) Lower cab (para 2-22b).
- (e) If engine speed is still not stable, notify Unit Maintenance.

a13. ENGINE STARTS BUT MISFIRES, RUNS ROUGH, OR LACKS POWER.

Step 1. Check for restricted air filter (para 2-21a or b).

- (a) If restricted, clean air filter element (para 3-9).
- (b) If air filter element will not clean, notify Unit Maintenance.

Table 3-2. Troubleshooting (Cont)

MALFUNCTION
TEST OR INSPECTION
CORRECTIVE ACTION
<p>a13. ENGINE STARTS BUT MISFIRES, RUNS ROUGH, OR LACKS POWER (CONT).</p> <p>Step 2. Check for fuel leaks.</p> <p>(a) Raise cab (para 2-22a).</p> <div data-bbox="537 600 1073 997" data-label="Image"> <p>The diagram shows a side view of the engine compartment of a vehicle. Three components are labeled with lines pointing to them: 'FUEL/WATER SEPARATOR' at the top, 'FUEL PRIMER PUMP' to its right, and 'SECONDARY FUEL FILTER' at the bottom left. An arrow points from the cab area towards the engine compartment.</p> </div> <p style="text-align: right; margin-right: 100px;">1C03A131</p>
<p>(b) Check secondary fuel filter, fuel lines, fuel fittings, draincocks, fuel tank lines and tank, and other lines that hold fuel for leaks.</p> <p>(c) If any fuel leaks are found, notify Unit Maintenance.</p> <p>(d) Lower cab (para 2-22b).</p> <p>(e) If engine starts but misfires, runs rough, or lacks power, notify Unit Maintenance.</p>
<p>a14. BLUE EXHAUST SMOKE.</p>
<p>Check for proper engine oil level.</p>
<p>(a) Raise cab (para 2-22a).</p> <p>(b) Check engine oil level (para 2-15, item 34).</p> <p>(c) If engine oil level is low, add engine oil (Appendix F).</p> <p>(d) If engine oil level is high, notify Unit Maintenance.</p> <p>(f) Lower cab (para 2-22b).</p> <p>(g) If blue exhaust smoke is still seen from engine, notify Unit Maintenance.</p>
<p>a15. LOW ENGINE POWER.</p>
<p>Step 1. Check fuel tank contamination.</p>
<p>If fuel tank contains contamination in fuel, notify Unit Maintenance.</p>

Table 3-2. Troubleshooting (Cont)

MALFUNCTION	TEST OR INSPECTION	CORRECTIVE ACTION
a. ENGINE SYSTEM (CONT)		
a15. LOW ENGINE POWER (CONT).		
	Step 2. Check for proper engine oil level.	
	(a) Raise cab (para 2-22a).	
	(b) Check engine oil level (para 2-18, item 34).	
	(c) If engine oil level is low, add engine oil (Appendix F).	
	(d) If engine oil level is high, notify Unit Maintenance.	
	Step 3. Check for restricted air filter (para 2-21a or b).	
	(a) If restricted, clean air filter element (para 3-9).	
	(b) If air filter element will not clean, notify Unit Maintenance.	
	Step 4. Check air cleaner hoses and pipe for kinks and damage.	
	(a) Check air particle restriction hose for kinks and damage.	
	(b) Check air cleaner to turbocharger pipe and hose for kinks or damage.	
	(c) If pipe or hose(s) are damaged or kinked, notify Unit Maintenance.	
	(d) Lower cab (para 2-22b).	
	(e) If engine has low power, notify Unit Maintenance.	
b. FUEL SYSTEM		
b1. ENGINE CRANKS BUT DOES NOT START OR ENGINE STALLS AFTER STARTING.		
	Step 1. Perform Engine System Troubleshooting (a2. Engine Cranks But Does Not Start).	
	Step 2. Check to see if fuel tank is empty.	
	(a) If fuel tank is empty, fill fuel tank (para 2-20a).	
	(b) If engine still cranks but does not start, perform Electrical System Troubleshooting (e5. Engine Cranks But Does Not Start).	
b2. ETHER STARTING AID DOES NOT OPERATE.		
	Notify Unit Maintenance.	

Table 3-2. Troubleshooting (Cont)

MALFUNCTION
TEST OR INSPECTION
CORRECTIVE ACTION
<p>b3. FUEL CONSUMPTION TOO HIGH.</p>
<p>Check for fuel leaks.</p>
<p>(a) Raise cab (para 2-22a).</p>
<p>The diagram shows a side view of the engine compartment of a vehicle. Three components are labeled with lines pointing to them: 'FUEL/WATER SEPARATOR' at the top, 'FUEL PRIMER PUMP' to its right, and 'SECONDARY FUEL FILTER' at the bottom left. An arrow originates from the cab area on the left and points towards the engine compartment.</p>
<p>1C03B031</p>
<p>(b) Check secondary fuel filter, fuel lines, fuel fittings, draincocks, fuel tank lines and tank, and other lines that hold fuel for leaks.</p>
<p>(c) If any fuel leaks are found, notify Unit Maintenance.</p>
<p>(d) If fuel consumption is still too high, notify Unit Maintenance.</p>
<p>(e) Lower cab (para 2-22b).</p>
<p>b4. ACCELERATOR PEDAL STICKS.</p>
<p>Notify Unit Maintenance.</p>
<p>c. EXHAUST SYSTEM</p>
<p>c1. EXHAUST SYSTEM UNUSUALLY NOISY OR VIBRATES EXCESSIVELY DURING ENGINE OPERATION.</p>
<p>Notify Unit Maintenance.</p>
<p>c2. EXHAUST FUMES IN CAB.</p>
<p>Notify Unit Maintenance.</p>

Table 3-2. Troubleshooting (Cont)

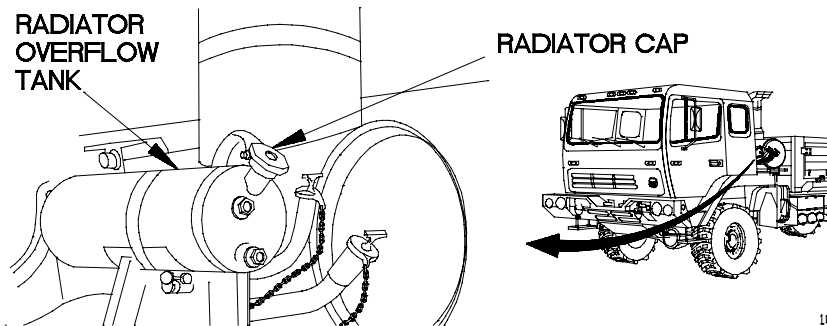
MALFUNCTION
TEST OR INSPECTION
CORRECTIVE ACTION

d. COOLING SYSTEM

d1. ENGINE OVERHEATS.

WARNING

Extreme care should be taken when removing coolant fill cap if temperature gage reads above 180°F (82°C). Contact with steam or hot coolant under pressure may result. Failure to comply may result in injury to personnel.



1C03D011

- Step 1. Check coolant level at radiator overflow tank.
 - If low, add coolant as required (Appendix F).
- Step 2. Check radiator cap for leakage and damage.
 - If leaking or damaged, notify Unit Maintenance.
- Step 3. Check radiator overflow tank and hoses for leaks and damage.
 - If leaking or damaged, notify Unit Maintenance.
- Step 4. Check outside of radiator core for obstructions.
 - (a) Raise cab (para 2-22a).
 - (b) Check radiator fins for obstructions.
 - (c) If clogged, remove debris.
- Step 5. Check for leakage from radiator hoses and hose connections.
 - (a) If loose, tighten.
 - (b) If damaged, notify Unit Maintenance.

Table 3-2. Troubleshooting (Cont)

MALFUNCTION	TEST OR INSPECTION	CORRECTIVE ACTION
d1. ENGINE OVERHEATS (CONT).	Step 6. Check for leakage from radiator hoses and hose connections.	<ul style="list-style-type: none"> (a) Lower cab (para 2-22b). (b) If engine continues to overheat, notify Unit Maintenance.
d2. OIL IN COOLING SYSTEM.	Notify Unit Maintenance.	
d3. LOSS OF COOLANT.		
WARNING		
Extreme care should be taken when removing coolant fill cap if temperature gage reads above 180°F (82°C). Contact with steam or hot coolant under pressure may result. Failure to comply may result in injury to personnel.		
	Step 1. Check radiator cap for leakage and damage.	If leaking or damaged, notify Unit Maintenance.
	Step 2. Check radiator overflow tank and hoses for leaks and damage.	If leaking or damaged, notify Unit Maintenance.
	Step 3. Check radiator fins for obstructions.	<ul style="list-style-type: none"> (a) Raise cab (para 2-22a). (b) Check radiator fins for obstructions. (c) If clogged, remove debris.
	Step 4. Check all hoses and connections for visual signs of leakage.	<ul style="list-style-type: none"> (a) If loose, tighten. (b) If damaged, notify Unit Maintenance. (c) Lower cab (para 2-22b). (d) If coolant loss is still seen, notify Unit Maintenance.

Table 3-2. Troubleshooting (Cont)

MALFUNCTION TEST OR INSPECTION CORRECTIVE ACTION			
e. ELECTRICAL SYSTEM			
NOTE			
This table is used to identify circuit breakers for electrical system troubleshooting.			
Reference Designator	Function	CB Amps	Circuit Voltage
CB1	Van AC Power	200	110/206
CB2	Van Air Conditioning Power	30	206
CB3	Van VAC Power	50	110/206
CB5	Van 110 VAC Outlets, Forward	20	110
CB6	Van AC Lighting	15	110
CB7	Van 110 VAC Outlets, Middle	20	110
CB8	Van Heater/Fan	15	110
CB9	Van 110 VAC Outlets, Rear	20	110
CB10	Van Blackout Lights	5	24
CB11	Van 24 VDC Outlets	20	24
CB20	Cab Radio	25	24
CB21	Air Dryer, Frequency Divider, and Starter Pushbutton Switch	15	24
CB22	Engine Fan Off Switch, Ether Start Solenoid, Ether Start Switch, Ether Sensor, Fan Solenoid, and Water Temperature Switch (fan)	10	24
CB23	Personnel Heater	15	24
CB30	Chemical Alarm, Chemical Detector, and Chemical Detector Indicator Light	10	24
CB35	WTEC II TEPSS and WTEC II VIM	15	12
CB36	Horn	20	24
CB37	Windshield Wiper ECU and Wiper Motor	20	24
CB38	Rotating Warning Light	20	12
CB39	24 VDC Intervehicular Blackout Stop Light	10	24
CB40	CTIS, CTIS Air Pressure Switch, CTIS Overspeed Indicator Light	10	24
CB41	24 VDC Intervehicular Clearance and Rear Light	15	24
CB42	24 VDC Intervehicular Blackout Clearance, Left Blackout Marker, and Right Blackout Marker	10	24
CB43	(WTEC II) 24 VDC Intervehicular Left Turn and Stoplight/(WTEC III) Transmission ECU	15	24

Table 3-2. Troubleshooting (Cont)

MALFUNCTION TEST OR INSPECTION CORRECTIVE ACTION			
Reference Designator	Function	CB Amps	Circuit Voltage
CB44	(WTEC II) 24 VDC Intervehicular Right Turn and Stoplight/ (WTEC III) (WTEC II) 24 VDC Intervehicular Left and Right Turn Signals and Stoplights	15	24
CB49	Fuel Water Separator, PTO Solenoid, PTO Switch, Winch In Solenoid, Winch In/Out Switch, Winch Out Solenoid, and Winch Switch	15	24
CB50	Van Door Switch	15	24
CB54	Blackout Drive Light	8	12
CB65	Front Left and Right Parking Lights	8	12
CB66	Front Left Blackout Marker, Front Right Blackout Marker, Rear LH Blackout Marker, Rear RH Blackout Marker, Blackout Signal to Van Body, and WTEC II/WTEC III TPSS Dimmer Module	8	12
CB67	12 VDC Intervehicular Marker Lights and All Marker Lights	25	12
CB68	M1088/M1089 Auxiliary Oil Coolers Fan Motors	25	24
CB70	Circuit Breaker CB54, Circuit Breaker CB65, Circuit Breaker CB66, Circuit Breaker CB74, Circuit Breaker CB76, Dimmer Module, Instrument and Auxiliary Panel Rocker Switch Lights, Instrument Panel and Auxiliary Panel Gage Lights, Main Light Switch, Master Power Switch, Personnel Heater Lights, Rotating Warning Light Switch and Headlight HI/LO Switch	20	12
CB71	Hazard Warning Switch and Turn Signal Flasher	15	12
CB72	Blackout Override Switch	15	12
CB73	Backup Light	8	12
CB74	Turn Signal Flasher ECU	10	12
CB76	12 VDC Intervehicular Left Turn Signal, Right Turn Signal, and Stoplight, 24 VDC Intervehicular Auxiliary, Front Left Turn Signal, Front Right Turn Signal, Hazard Warning Switch, Left Blackout Stoplight, Left Turn Signal Indicator Light, Rear Left Composite Lamp Turn Signal, Rear Right Composite Lamp Turn Signal, Right Blackout Stoplight, Right Turn Signal Indicator Light, and Stoplight Switch (A) and (B)	15	12

Table 3-2. Troubleshooting (Cont)

MALFUNCTION TEST OR INSPECTION CORRECTIVE ACTION			
e. ELECTRICAL SYSTEM (CONT)			
Reference Designator	Function	CB Amps	Circuit Voltage
CB77	Instrument and Auxiliary Panel Gages, Audible Alarm, Emergency Brake Indicator Light, Engine Fan Off Indicator Light, Engine Fan Off Switch, Engine Oil Pressure Indicator Light, Engine Oil Pressure Sensor, Engine Oil Pressure Switch, Front Brake Air Indicator Light, Front Brake Air Indicator Light Switch, Front Brake Air Pressure Transmitter, Magnetic Pickup, Master Stop Indicator, Parking Brake Indicator Light, Parking Brake Switch, PTO Indicator Light, PTO Pressure Switch, Rear Brake Air Indicator Light, Rear Brake Air Pressure Transmitter, Transmission Temperature Indicator Light, Troop Transport Alarm Switch, Water Temperature Indicator Light, Water Temperature Sensor, Van Door Indicator Light, Water Temperature Switch, and Fuel Level Sensor	10	12
CB78	Left and Right Headlight	15	12
CB79	WTEC II 10 AMP Fuse TEPSS, Fuel Solenoid, Start Inhibit Pushbutton Switch, and WTEC III Transmission ECU	15	24
CB80	12 VDC Intervehicular Taillight, Left Rear Composite Lamp Taillight, and Right Rear Composite Lamp Taillight	25	12

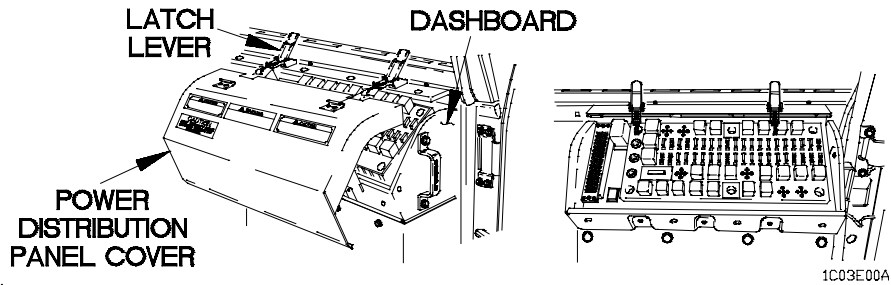


Table 3-2. Troubleshooting (Cont)

MALFUNCTION
TEST OR INSPECTION
CORRECTIVE ACTION
<p>e1. ENGINE DOES NOT CRANK.</p>
<p>NOTE</p>
<p>Perform a1. ENGINE DOES NOT CRANK, before beginning step (1).</p>
<p>Step 1. Check to see if service lights illuminate.</p>
<p>(a) Position main light switch to SER DRIVE (para 2-21c).</p>
<p>If service lights illuminate, perform step 2 of this fault.</p>
<p>If service lights do not illuminate, perform Electrical System Troubleshooting (e2. 12 VDC AND 24 VDC CIRCUITS DO NOT OPERATE).</p>
<p>(b) Position main light switch to OFF (para 2-21c).</p>
<p>Step 2. Check to see if windshield wipers operate.</p>
<p>(a) Position master power switch to on (para 2-21a or b).</p>
<p>(b) Position windshield wiper switch to "I" (para 2-4).</p>
<p>If windshield wipers operate, perform step 3 of this fault.</p>
<p>If windshield wipers do not operate, perform Electrical System Troubleshooting (e3. 24 VDC CIRCUITS DO NOT OPERATE).</p>
<p>(c) Position windshield wiper switch to "O" (para 2-4).</p>
<p>(d) Position master power switch to off (para 2-21f).</p>
<p>Step 3. Check to see if WTEC II Transmission ECU Pushbutton Shift Selector (TEPSS) or WTEC III Transmission Pushbutton Shift Selector (TPSS) is neutral (N).</p>
<p>(a) Position master power switch to on (para 2-21a or b).</p>
<p>If WTEC II TEPSS or WTEC III TPSS is blank, perform Transmission Troubleshooting (f4. TRANSMISSION PUSHBUTTON SHIFT SELECTOR DOES NOT OPERATE).</p>
<p>(b) If WTEC II TEPSS or WTEC III TPSS displays any other setting than neutral (N), press N on WTEC II TEPSS or WTEC III TPSS.</p>
<p>If WTEC II TEPSS or WTEC III TPSS is in neutral (N), perform step 4 of this fault.</p>
<p>If WTEC II TEPSS or WTEC III TPSS will not go into neutral (N), beeps or displays "--", perform Transmission System Troubleshooting (f1. WTEC II TEPSS EMITS EIGHT SECONDS OF BEEPS AND/OR TRANSMISSION DOES NOT SHIFT GEARS or f3. WTEC III TPSS DISPLAYS "--" AND/OR TRANSMISSION DOES NOT SHIFT GEARS).</p>
<p>(c) Position master power switch to off (para 2-21f).</p>
<p>Step 4. Check circuit breakers (CB21 and CB77) in Power Distribution Panel (PDP) to see if either is tripped.</p>
<p>(a) Remove PDP cover (para 3-13a).</p>
<p>(b) Check circuit breakers (CB21 and CB77) to see if either is tripped.</p>

Table 3-2. Troubleshooting (Cont)

MALFUNCTION	TEST OR INSPECTION	CORRECTIVE ACTION
e. ELECTRICAL SYSTEM (CONT)		
e1.	ENGINE DOES NOT CRANK.	<p>If either circuit breaker (CB21 or CB77) is tripped, push in to reset.</p> <p>(c) Attempt to start engine (para 2-21a or b).</p> <p>(d) If engine still does not crank, check circuit breakers (CB21 and CB77) to see if either is tripped.</p> <p>If either circuit breaker (CB21 or CB77) is tripped or engine does not crank, Notify Unit Maintenance.</p> <p>(e) Install PDP cover (para 3-13b).</p> <p>(f) Position master power switch to off (para 2-21f).</p>
e2.	12 VDC AND/OR 24 VDC CIRCUITS DO NOT OPERATE.	<p>Step 1. Check circuit breaker (CB70) in Power Distribution Panel (PDP) to see if it is tripped.</p> <p>(a) Remove PDP cover (para 3-13a).</p> <p>(b) Check circuit breaker (CB70) to see if it is tripped.</p> <p>If circuit breaker (CB70) is tripped, push in to reset.</p> <p>Step 2. Check to see if service lights illuminate.</p> <p>(a) Position main light switch to SER DRIVE (para 2-21c).</p> <p>If service lights do not illuminate, Notify Unit Maintenance.</p> <p>(b) Position main light switch to OFF (para 2-21c).</p> <p>(c) Install PDP cover (para 3-13b).</p>
e3.	24 VDC CIRCUITS DO NOT OPERATE.	<p style="text-align: center;">NOTE</p> <p>Perform a1. ENGINE DOES NOT CRANK, prior to beginning this task.</p> <p>Notify Unit Maintenance.</p>
e4.	Deleted.	Deleted.
e5.	ENGINE CRANKS BUT DOES NOT START.	<p style="text-align: center;">NOTE</p> <p>Perform Engine System Troubleshooting Task (a2. Engine Cranks But Does Not Start before performing this task).</p> <p>Notify Unit Maintenance.</p>

Table 3-2. Troubleshooting (Cont)

MALFUNCTION
TEST OR INSPECTION
CORRECTIVE ACTION
<p>e6. FUEL GAGE DOES NOT OPERATE OR IS INACCURATE.</p> <p>Step 1. Fill fuel tank.</p> <p>If FUEL gage shows less than full, notify Unit Maintenance.</p> <p>Step 2. Check circuit breaker (CB77) in PDP to see if it is tripped.</p> <ul style="list-style-type: none"> (a) Remove PDP cover (para 3-13a). (b) Position master power switch to off (para 2-21f). (c) If circuit breaker is tripped, push in to reset. (c) Position master power switch to on (para 2-21a or b). (d) Check circuit breaker to see if it tripped again. If circuit breaker is tripped again, notify Unit Maintenance. (e) Position master power switch to off (para 2-21f). (f) Install PDP cover (para 3-13b). (g) If FUEL gage still does not operate or is inaccurate, notify Unit Maintenance. <p>e7. WATER TEMP GAGE DOES NOT OPERATE OR IS INACCURATE.</p> <p>Check circuit breaker (CB77) in PDP to see if it is tripped.</p> <ul style="list-style-type: none"> (a) Remove PDP cover (para 3-13a). (b) Position master power switch to off (para 2-21f). (c) If circuit breaker is tripped, push in to reset. (d) Position master power switch to on (para 2-21a or b). (e) Check circuit breaker in electrical panel to see if it tripped. If circuit breaker tripped again, notify Unit Maintenance. (f) Position master power switch to off (para 2-21f). (g) Install PDP cover (para 3-13b). (h) If WATER TEMP gage still does not operate or is inaccurate, notify Unit Maintenance. <p>e8. REAR BRAKE AIR PRESSURE GAGE DOES NOT OPERATE OR IS INACCURATE.</p> <p>Step 1. Check to see if there is air in air tanks.</p> <ul style="list-style-type: none"> (a) Start engine (para 2-21a or b). (b) Allow vehicle to idle for approximately two minutes. (c) Shut down engine (para 2-21f).

Table 3-2. Troubleshooting (Cont)

MALFUNCTION	TEST OR INSPECTION	CORRECTIVE ACTION
e. ELECTRICAL SYSTEM (CONT)		
e8.	REAR BRAKE AIR PRESSURE GAGE DOES NOT OPERATE OR IS INACCURATE (CONT).	<div style="text-align: center; border: 1px solid black; padding: 5px; width: fit-content; margin: 0 auto;">WARNING</div> <p>Wear protective goggles to protect against possible injury from release of high pressure air. Failure to comply may result in injury to personnel.</p> <p>(d) Open drain valve on primary air tank.</p> <p>If air pressure is not present, perform Air System Troubleshooting (j1. Air System Loses Pressure During Operation/Slow Air Pressure Buildup).</p> <p>Step 2. Check to see if the FRONT BRAKE AIR pressure gage is operating.</p> <p>(a) Start engine (para 2-21a or b).</p> <p>(b) Allow vehicle to idle for approximately two minutes.</p> <p>If FRONT BRAKE pressure gage is not operating, notify Unit Maintenance.</p> <p>If FRONT BRAKE AIR pressure gage is not operating, perform Electrical System Troubleshooting (e9. FRONT AIR PRESSURE GAGE DOES NOT OPERATE OR IS INACCURATE).</p> <p>(c) Shut down engine (para 2-21f).</p>
e9.	FRONT BRAKE AIR PRESSURE GAGE DOES NOT OPERATE OR IS INACCURATE.	<p>Step 1. Check to see if there is air in air tanks.</p> <p>(a) Start engine (para 2-21a or b).</p> <p>(b) Allow vehicle to idle for approximately two minutes.</p> <p>(c) Shut down engine (para 2-21f).</p> <div style="text-align: center; border: 1px solid black; padding: 5px; width: fit-content; margin: 10px auto;">WARNING</div> <p>Wear protective goggles to protect against possible injury from release of high pressure air. Failure to comply may result in injury to personnel.</p> <p>(d) Open drain valve on primary air tank.</p> <p>If air pressure is not present, perform Air System Troubleshooting task (j1. Air System Loses Pressure During Operation/Slow Air Pressure Buildup).</p> <p>(e) Close drain valve on primary air tank.</p> <p>Step 2. Check to see if the FUEL gage is operating.</p> <p>(a) Position master power switch to on (para 2-21a or b).</p> <p>If FUEL gage is operating, Notify Unit Maintenance.</p>

Table 3-2. Troubleshooting (Cont)

MALFUNCTION
TEST OR INSPECTION
CORRECTIVE ACTION
<p>e9. FRONT BRAKE AIR PRESSURE GAGE DOES NOT OPERATE OR IS INACCURATE (CONT).</p>
<p>If FUEL gage is not operating, perform Electrical System Troubleshooting (e6. FUEL GAGE DOES NOT OPERATE OR IS INACCURATE).</p>
<p>(b) Position master power switch to off (para 2-21f).</p>
<p>e10. OIL PRESSURE GAGE DOES NOT OPERATE OR IS INACCURATE.</p>
<p>Step 1. Check to see if VOLTS gage is operating.</p>
<p>If VOLTS gage does not operate, perform Electrical System Troubleshooting (e12 VOLTS Gage Does Not Operate or is Inaccurate).</p>
<p>If VOLTS gage does operate, go to step 2 of this malfunction.</p>
<p>Step 2. Check for proper engine oil level.</p>
<p>(a). Raise cab (para 2-22a).</p>
<p>(b). Check engine oil level (para 2-18, Item 34).</p>
<p>If engine oil level is low, add engine oil (Appendix F).</p>
<p>If engine oil level is high, notify Unit Maintenance.</p>
<p>If engine oil level is within the full range, go to step 3 of this fault.</p>
<p>(c). Lower cab (para 2-22b).</p>
<p>Step 3. Check to see if engine oil pressure indicator goes out after engine starts.</p>
<p>(a). Start engine (para 2-21a or b).</p>
<p>(b). Check to see if engine oil pressure indicator goes out after engine starts.</p>
<p>If engine oil pressure indicator does not go out after engine starts, perform Engine System Troubleshooting (a3. Low or High Engine Oil Pressure).</p>
<p>If engine oil pressure indicator does go out after engine starts, notify Unit Maintenance.</p>
<p>(c). Shut down engine (para 2-21f).</p>
<p>e11. SPEEDOMETER DOES NOT OPERATE OR IS INACCURATE.</p>
<p>Check to see if WATER TEMP gage is operating.</p>
<p>If WATER TEMP gage is operating, notify Unit Maintenance.</p>
<p>If WATER TEMP gage is not operating, perform Electrical System Troubleshooting (e7. WATER TEMP Gage Does Not Operate or Is Inaccurate).</p>
<p>e12. VOLTS GAGE DOES NOT OPERATE OR IS INACCURATE.</p>
<p>Check circuit breaker (CB77) in PDP to see if it is tripped.</p>
<p>(a) Position master power switch to off (para 2-21f).</p>
<p>(b) Remove PDP cover (para 3-13a).</p>
<p>(c) If circuit breaker is tripped, push in to reset.</p>

Table 3-2. Troubleshooting (Cont)

MALFUNCTION	TEST OR INSPECTION	CORRECTIVE ACTION
e. ELECTRICAL SYSTEM (CONT)		
e12.	VOLTS GAGE DOES NOT OPERATE OR IS INACCURATE (Cont).	<ul style="list-style-type: none"> (d) Install PDP cover (para 3-13b). (e) Position master power switch to on (para 2-21a or b). (f) If VOLTS gage still does not operate or is inaccurate, notify Unit Maintenance. (c) Position master power switch to off (para 2-21f).
e13.	TACHOMETER DOES NOT OPERATE OR IS INACCURATE.	<p>Check to see if tachometer illuminates.</p> <ul style="list-style-type: none"> (a) Position main light switch main selector lever to SER DRIVE (para 2-21c). (b) Position main light switch auxiliary lever PNL BRT (para 2-21c). (c) Observe if tachometer illuminates. (d) Position main light switch auxiliary lever to OFF (para 2-21c). (e) Position main light switch main selector lever to OFF (para 2-21c). <p>If tachometer does not illuminate, notify Unit Maintenance.</p> <p>Check to see if VOLTS gage is operating.</p> <p>If VOLTS gage is operating, notify Unit Maintenance.</p> <p>If VOLTS gage is not operating, perform Electrical System Troubleshooting (e12. VOLTS Gage Does Not Operate or Is Inaccurate).</p>
e14.	SINGLE TONE AUDIBLE ALARM DOES NOT OPERATE (ALL MODELS EXCEPT M1078/M1081).	<p>Check to see if any lights on Lighted Indicator Display (LID) operate.</p> <ul style="list-style-type: none"> (a) Position master power switch to on (para 2-21a or b). (b) If any lights operate on LID, notify Unit Maintenance. (c) If no lights operate on LID, perform Electrical System Troubleshooting (e37. Master STOP Indicator Does Not Operate). (d) Position master power switch to off (para 2-21f).
e14a.	TROOP TRANSPORT AUDIBLE ALARM DOES NOT OPERATE.	<p>Check to see if steady tone audible alarm operates.</p> <ul style="list-style-type: none"> (a) Start engine (para 2-21a or b). (b) Depress brake pedal, fully to the floor, five or six times. (c) If steady tone audible alarm operates, notify Unit Maintenance. (d) If steady tone audible alarm does not operate, perform Electrical System Troubleshooting (e14. Audible Alarm Does Not Operate).

Table 3-2. Troubleshooting (Cont)

MALFUNCTION	TEST OR INSPECTION	CORRECTIVE ACTION
e14a. TROOP TRANSPORT AUDIBLE ALARM DOES NOT OPERATE(Cont).	(e) Shut down engine (para 2-21f).	
e14b. MASTER POWER SWITCH DOES NOT SHUT DOWN ENGINE.	Shut down engine using start inhibit switch.	
	(a) Position master power switch to off (para 2-21f).	
	(b) Remove PDP cover (para 3-13a).	
	(c) Press start inhibit switch.	
	(d) Install PDP cover (para 3-13b).	
	(e) Notify Unit Maintenance.	
e15. LAMP TEST SWITCH DOES NOT ILLUMINATE.	Check to see if radiator fan off switch illuminates.	

Table 3-2. Troubleshooting (Cont)

MALFUNCTION	TEST OR INSPECTION	CORRECTIVE ACTION
e15. LAMP TEST SWITCH DOES NOT ILLUMINATE (CONT).	<ul style="list-style-type: none"> (a) Position main light switch main selector lever to SER DRIVE (para 2-21c). (b) Position main light switch auxiliary lever to PNL BRT (para 2-21c) and observe if radiator fan off switch illuminates. (c) Position main light switch auxiliary lever to OFF (para 2-21c). (d) Position main light switch main selector to OFF (para 2-21c). 	<p>If radiator fan off switch illuminates, notify Unit Maintenance.</p> <p>If radiator fan off switch does not illuminate, perform Electrical System Troubleshooting (e16. Radiator Fan Off Switch Does Not Illuminate).</p>
e16. RADIATOR FAN OFF SWITCH DOES NOT ILLUMINATE.	<p>Check to see if REAR BRAKE AIR gage illuminates.</p> <ul style="list-style-type: none"> (a) Position main light switch main selector lever to SER DRIVE (para 2-21c). (b) Position main light switch auxiliary lever to PNL BRT (para 2-21c) and observe if REAR BRAKE AIR gage illuminates. (c) Position main light switch auxiliary lever to OFF (para 2-21c). (d) Position main light switch main selector lever to OFF (para 2-21c). 	<p>If REAR BRAKE AIR gage illuminates, notify Unit Maintenance.</p> <p>If REAR BRAKE AIR gage does not illuminate, perform Electrical System Troubleshooting (e17. REAR BRAKE AIR Gage Does Not Illuminate).</p>
e16a. ETHER START SWITCH DOES NOT ILLUMINATE.	<p>Check to see if FUEL gage illuminates.</p> <ul style="list-style-type: none"> (a) Position main light switch main selector lever to SER DRIVE (para 2-21c). (b) Position main light switch auxiliary lever to PNL BRT (para 2-21c) and observe if FUEL gage illuminates). (c) Position main light switch auxiliary lever to OFF (para 2-21c). (d) Position main light switch main selector lever to OFF (para 2-21c). 	<p>If FUEL gage illuminates, notify Unit Maintenance.</p> <p>If FUEL gage does not illuminate, perform Electrical System Troubleshooting (e17a. FUEL Gage Does Not Illuminate).</p>
e16b. HAZARD LIGHTS SWITCH DOES NOT ILLUMINATE.	<p>Check to see if amber warning light switch illuminates.</p> <ul style="list-style-type: none"> (a) Position main light switch main selector lever to SER DRIVE (para 2-21c). (b) Position main light switch auxiliary lever to PNL BRT (para 2-21c) and observe if amber warning light switch illuminates. 	

Table 3-2. Troubleshooting (Cont)

MALFUNCTION	TEST OR INSPECTION	CORRECTIVE ACTION
e. ELECTRICAL SYSTEM (CONT)		
e16b. HAZARD LIGHTS SWITCH DOES NOT ILLUMINATE (CONT).	<ul style="list-style-type: none"> (c) Position main light switch auxiliary lever to OFF (para 2-21c). (d) Position main light switch main selector lever to OFF (para 2-21c). 	<p>If amber warning light switch illuminates, notify Unit Maintenance.</p> <p>If amber warning light switch does not illuminate, perform Electrical System Troubleshooting (e16c. Amber Warning Light Switch Does Not Illuminate).</p>
e16c. AMBER WARNING LIGHT SWITCH DOES NOT ILLUMINATE.	<p>Check to see if master power switch illuminates.</p> <ul style="list-style-type: none"> (a) Position main light switch main selector to SER DRIVE (para 2-21c). (b) Position main light switch auxiliary lever to PNL BRT (para 2-21c) and observe if master power switch illuminates. (c) Position main light switch auxiliary lever to OFF (para 2-21c). (d) Position main light switch main selector lever to OFF (para 2-21c). 	<p>If master power switch illuminates, notify Unit Maintenance.</p> <p>If master power switch does not illuminate, perform Electrical System Troubleshooting (e16d. Master Power Switch Does Not Illuminate).</p>
e16d. MASTER POWER SWITCH DOES NOT ILLUMINATE.	<p>Check to see if OIL PRESS gage illuminates.</p> <ul style="list-style-type: none"> (a) Position main light switch main selector lever to SER DRIVE (para 2-21c). (b) Position main light switch auxiliary lever to PNL BRT (para 2-21c) and observe if oil PRESS gage illuminates. (c) Position main light switch auxiliary lever to OFF (para 2-21c). (d) Position main light switch main selector lever to OFF (para 2-21c). 	<p>If OIL PRESS gage illuminates, notify Unit Maintenance.</p> <p>If OIL PRESS gage does not illuminate, perform Electrical System Troubleshooting (e17f. OIL PRESS Gage Does Not Illuminate).</p>
e17. REAR BRAKE AIR GAGE DOES NOT ILLUMINATE.	<p>Check to see if ether start switch illuminates.</p> <ul style="list-style-type: none"> (a) Position main light switch main selector lever to SER DRIVE (para 2-21c). (b) Position main light switch auxiliary lever to PNL BRT (para 2-21c) and observe if ether start switch illuminates. (c) Position main light switch auxiliary lever to OFF (para 2-21c). 	

Table 3-2. Troubleshooting (Cont)

MALFUNCTION	TEST OR INSPECTION	CORRECTIVE ACTION
e17. REAR BRAKE AIR GAGE DOES NOT ILLUMINATE (CONT).	(d) Position main light switch main selector lever to OFF (para 2-21c).	<p>If ether start switch illuminates, notify Unit Maintenance.</p> <p>If ether start switch does not illuminate, perform Electrical System Troubleshooting (e16a. Ether Start Switch Does Not Illuminate).</p>
e17a. FUEL GAGE DOES NOT ILLUMINATE.	Check to see if FRONT BRAKE AIR gage illuminates.	<p>(a) Position main light switch main selector lever to SER DRIVE (para 2-21c).</p> <p>(b) Position main light switch auxiliary lever to PNL BRT (para 2-21c) and observe if FRONT BRAKE AIR gage illuminates.</p> <p>(c) Position main light switch auxiliary lever to OFF (para 2-21c).</p> <p>(d) Position main light switch main selector lever to OFF (para 2-21c).</p> <p>If FRONT BRAKE AIR gage illuminates, notify Unit Maintenance.</p> <p>If FRONT BRAKE AIR gage does not illuminate, perform Electrical System Troubleshooting (e17b. FRONT BRAKE AIR Gage Does Not Illuminate).</p>
e17b. FRONT BRAKE AIR GAGE DOES NOT ILLUMINATE.	Check to see if speedometer illuminates.	<p>(a) Position main light switch main selector lever to SER DRIVE (para 2-21c).</p> <p>(b) Position main light switch auxiliary lever to PNL BRT (para 2-21c) and observe if speedometer illuminates.</p> <p>(c) Position main light switch auxiliary lever to OFF (para 2-21c).</p> <p>(d) Position main light switch main selector lever to OFF (para 2-21c).</p> <p>If speedometer illuminates, notify Unit Maintenance.</p> <p>If speedometer does not illuminate, perform Electrical System Troubleshooting (e17c. Speedometer Does Not Illuminate).</p>
e17c. SPEEDOMETER DOES NOT ILLUMINATE.	Check to see if VOLTS gage illuminates.	<p>(a) Position main light switch main selector lever to SER DRIVE (para 2-21c).</p> <p>(b) Position main light switch auxiliary lever to PNL BRT (para 2-21c) and observe if VOLTS gage illuminates.</p> <p>(c) Position main light switch auxiliary lever to OFF (para 2-21c).</p> <p>(d) Position main light switch main selector lever to OFF (para 2-21c).</p>

Table 3-2. Troubleshooting (Cont)

MALFUNCTION	TEST OR INSPECTION	CORRECTIVE ACTION
e. ELECTRICAL SYSTEM (CONT)		
e17c. SPEEDOMETER DOES NOT ILLUMINATE (CONT).	If VOLTS gage illuminates, notify Unit Maintenance.	If VOLTS gage does not illuminate, perform Electrical System Troubleshooting (e17d. VOLTS Gage Does Not Illuminate).
e17d. VOLTS GAGE DOES NOT ILLUMINATE.	Check to see if WATER TEMP gage illuminates.	<ul style="list-style-type: none"> (a) Position main light switch main selector lever to SER DRIVE (para 2-21c). (b) Position main light switch auxiliary lever to PNL BRT (para 2-21c) and observe if WATER TEMP gage illuminates. (c) Position main light switch auxiliary lever to OFF (para 2-21c). (d) Position main light switch main selector lever to OFF (para 2-21c). If WATER TEMP gage illuminates, notify Unit Maintenance. If WATER TEMP gage does not illuminate, perform Electrical System Troubleshooting (e17e. WATER TEMP Gage Does Not Illuminate).
e17e. WATER TEMP GAGE DOES NOT ILLUMINATE.	Check to see if OIL PRESS gage illuminates.	<ul style="list-style-type: none"> (a) Position main light switch main selector lever to SER DRIVE (para 2-21c). (b) Position main light switch auxiliary lever to PNL BRT (para 2-21c) and observe if OIL PRESS gage illuminates. (c) Position main light switch auxiliary lever to OFF (para 2-21c). (d) Position main light switch main selector lever to OFF (para 2-21c). If OIL PRESS gage illuminates, notify Unit Maintenance. If OIL PRESS gage does not illuminate, check circuit breaker (CB70) on PDP to see if it is tripped. <ul style="list-style-type: none"> (a) Remove PDP cover (para 3-13a). (b) If circuit breaker is tripped, push in to reset. (c) Install PDP cover (para 3-13b). (d) Position main light switch main selector lever to SER DRIVE (para 2-21c). (e) Position main light switch auxiliary lever to PNL BRT (para 2-21c) and observe if WATER TEMP gage illuminates. (f) If WATER TEMP gage does not illuminate, notify Unit Maintenance.

Table 3-2. Troubleshooting (Cont)

MALFUNCTION
TEST OR INSPECTION
CORRECTIVE ACTION
<p>e17e. WATER TEMP GAGE DOES NOT ILLUMINATE (CONT).</p> <ul style="list-style-type: none"> (g) Position main light switch auxiliary lever to OFF (para 2-21c). (h) Position main light switch main selector lever to OFF (para 2-21c). <p>e17f. OIL PRESS GAGE DOES NOT ILLUMINATE.</p> <p>Check to see if WATER TEMP gage illuminates.</p> <ul style="list-style-type: none"> (a) Position main light switch main selector lever to SER DRIVE (para 2-21c). (b) Position main light switch auxiliary lever to PNL BRT (para 2-21c) and observe if WATER TEMP gage illuminates. (c) Position main light switch auxiliary lever to OFF (para 2-21c). (d) Position main light switch main selector lever to OFF (para 2-21c). <p>If WATER TEMP gage illuminates, notify Unit Maintenance.</p> <p>If WATER TEMP gage does not illuminate, check circuit breaker (CB70) on PDP to see if it is tripped.</p> <ul style="list-style-type: none"> (a) Remove PDP cover (para 3-13a). (b) If circuit breaker is tripped, push in to reset. (c) Install PDP cover (para 3-13b). (d) Position main light switch main selector lever to SER DRIVE (para 2-21c). (e) Position main light switch auxiliary lever to PNL BRT (para 2-21c) and observe if OIL PRESS gage illuminates. (f) If OIL PRESS gage does not illuminate, notify Unit Maintenance. (g) Position main light switch auxiliary lever to OFF (para 2-21c). (h) Position main light switch selector lever to OFF (para 2-21c). <p>e18. AUXILIARY PANEL, PERSONNEL HEATER, AND INSTRUMENT PANEL DO NOT ILLUMINATE.</p> <p>Check circuit breaker (CB23) in PDP to see if it is tripped.</p> <ul style="list-style-type: none"> (a) Remove PDP cover (para 3-13a). (b) Position main light switch to OFF (para 2-21c). (c) If circuit breaker is tripped, push in to reset. (d) Position main light switch to SER DRIVE (para 2-21c). (e) Check circuit breaker to see if it tripped. If circuit breaker is tripped, notify Unit Maintenance. (f) Position main light switch to OFF (para 2-21c). (g) Install PDP cover (para 3-13b).

Table 3-2. Troubleshooting (Cont)

MALFUNCTION	TEST OR INSPECTION	CORRECTIVE ACTION
e. ELECTRICAL SYSTEM (CONT)		
e18.	AUXILIARY PANEL, PERSONNEL HEATER, AND INSTRUMENT PANEL DO NOT ILLUMINATE (CONT).	(h) If auxiliary panel, personnel heater, and instrument panel still do not illuminate, notify Unit Maintenance.
e19.	TACHOMETER DOES NOT ILLUMINATE.	<p>Check to see if hazard lights switch illuminates.</p> <p>(a) Position main light switch main selector lever to SER DRIVE (para 2-21c).</p> <p>(b) Position main light switch auxiliary lever to PNL BRT (para 2-21c) and observe if hazard lights switch illuminates.</p> <p>(c) Position main light switch auxiliary lever to OFF (para 2-21c).</p> <p>(d) Position main light switch main selector lever to OFF (para 2-21c).</p> <p>If hazard lights switch illuminates, notify Unit Maintenance.</p> <p>If hazard lights switch does not illuminate, perform Electrical System Troubleshooting (e16b. Hazard Lights Switch Does Not Illuminate).</p>
e20.	AUXILIARY PANEL SWITCH DOES NOT ILLUMINATE.	<p>Check circuit breaker (CB23) in PDP to see if it is tripped.</p> <p>(a) Remove PDP cover (para 3-13a).</p> <p>(b) Position main light switch to OFF (para 2-21c).</p> <p>(c) If circuit breaker is tripped, push in to reset.</p> <p>(d) Position main light switch to SER DRIVE (para 2-21c).</p> <p>(e) Check circuit breaker to see if it tripped. If circuit breaker is tripped, notify Unit Maintenance.</p> <p>(f) Position main light switch to OFF (para 2-21c).</p> <p>(g) Install PDP cover (para 3-13b).</p> <p>(h) If auxiliary panel switch still does not illuminate, notify Unit Maintenance.</p>
e21.	AUXILIARY PANEL DOES NOT ILLUMINATE.	<p>Check circuit breaker (CB23) in PDP to see if it is tripped.</p> <p>(a) Remove PDP cover (para 3-13a).</p> <p>(b) Position main light switch to OFF (para 2-21c).</p> <p>(c) If circuit breaker is tripped, push in to reset.</p> <p>(d) Position main light switch to SER DRIVE (para 2-21c).</p>

Table 3-2. Troubleshooting (Cont)

MALFUNCTION	TEST OR INSPECTION	CORRECTIVE ACTION
e21.	AUXILIARY PANEL DOES NOT ILLUMINATE (CONT).	<ul style="list-style-type: none"> (e) Check circuit breaker to see if it tripped. If circuit breaker is tripped, notify Unit Maintenance. (f) Position main light switch to OFF (para 2-21c). (g) Install PDP cover (para 3-13b). (h) If auxiliary panel still does not illuminate, notify Unit Maintenance.
e22.	HIGH ENGINE TEMPERATURE INDICATOR DOES NOT ILLUMINATE.	<p>Check circuit breaker (CB77) in PDP to see if it is tripped.</p> <ul style="list-style-type: none"> (a) Remove PDP cover (para 3-13a). (b) Position main light switch to OFF (para 2-21c). (c) If circuit breaker is tripped, push in to reset. (d) Position main light switch to SER DRIVE (para 2-21c). (e) Check circuit breaker to see if it tripped. If circuit breaker is tripped, notify Unit Maintenance. (f) Position main light switch to OFF (para 2-21c). (g) Install PDP cover (para 3-13b). (h) If high engine temperature indicator still does not illuminate, notify Unit Maintenance.
e22a.	HIGH ENGINE TEMPERATURE INDICATOR ILLUMINATES	<p>Does WATER TEMP gage read below 216°F (102°C) when high engine temperature indicator illuminates?</p> <ul style="list-style-type: none"> (a) Start engine (para 2-21a or b). <ul style="list-style-type: none"> If WATER TEMP gage does not read above 216°F (102°C), notify Unit Maintenance. If WATER TEMP gage does read above 216°F (102°C), perform Cooling System Troubleshooting (d1. Engine Overheats). (b) Shut down engine (para 2-21f).
e23.	CENTRAL TIRE INFLATION SYSTEM (CTIS) OVERSPEED INDICATOR DOES NOT ILLUMINATE.	<p>Check circuit breaker (CB40) in PDP to see if it is tripped.</p> <ul style="list-style-type: none"> (a) Remove PDP cover (para 3-13a). (b) Position main light switch to OFF (para 2-21c). (c) If circuit breaker is tripped, push in to reset. (d) Position main light switch to SER DRIVE (para 2-21c).

Table 3-2. Troubleshooting (Cont)

MALFUNCTION
TEST OR INSPECTION
CORRECTIVE ACTION
<p>e23. CENTRAL TIRE INFLATION SYSTEM (CTIS) OVERSPEED INDICATOR DOES NOT ILLUMINATE (CONT).</p>
<p>(e) Check circuit breaker to see if it tripped. If circuit breaker is tripped, notify Unit Maintenance.</p>
<p>(f) Position main light switch to OFF (para 2-21c).</p>
<p>(g) Install PDP cover (para 3-13b).</p>
<p>(h) If CTIS overspeed indicator still does not illuminate, notify Unit Maintenance.</p>
<p>e24. CHEMICAL DETECTOR INDICATOR DOES NOT ILLUMINATE.</p>
<p>Check circuit breaker (CB30) in PDP to see if it is tripped.</p>
<p>(a) Remove PDP cover (para 3-13a).</p>
<p>(b) Position main light switch to OFF (para 2-21c).</p>

Table 3-2. Troubleshooting (Cont)

MALFUNCTION	TEST OR INSPECTION	CORRECTIVE ACTION
e. ELECTRICAL SYSTEM (CONT)		
e24.	CHEMICAL DETECTOR INDICATOR DOES NOT ILLUMINATE (CONT).	
	(c)	If circuit breaker is tripped, push in to reset.
	(d)	Position main light switch to SER DRIVE (para 2-21c).
	(e)	Check circuit breaker to see if it tripped. If circuit breaker is tripped, notify Unit Maintenance.
	(f)	Position main light switch to OFF (para 2-21c).
	(g)	Install PDP cover (para 3-13b).
	(h)	If chemical detector indicator still does not illuminate, notify Unit Maintenance.
e25.	LEFT TURN SIGNAL INDICATOR DOES NOT ILLUMINATE.	
	Step 1.	Check operation of turn signals (para 2-15, item 21). If turn signals do not illuminate, go to step 2. If turn signals are ok, notify Unit Maintenance.
	Step 2.	Check for illumination of high beam indicator (para 2-21c). If high beam indicator does not illuminate, perform Electrical System Troubleshooting (e27. Turn Signal Indicator And High Beam Indicator Do Not Illuminate).
	Step 3.	Check circuit breaker (CB74) in PDP to see if it is tripped.
	(a)	Remove PDP cover (para 3-13a).
	(b)	Position main light switch to OFF (para 2-21c).
	(c)	If circuit breaker is tripped, push in to reset.
	(d)	Position main light switch to SER DRIVE (para 2-21c).
	(e)	Check circuit breaker to see if it tripped. If circuit breaker is tripped, notify Unit Maintenance.
	(f)	Position main light switch to OFF (para 2-21c).
	(g)	Install PDP cover (para 3-13b).
	(h)	If left turn signal indicator still does not illuminate, notify Unit Maintenance.
e26.	RIGHT TURN SIGNAL INDICATOR DOES NOT ILLUMINATE.	
	Step 1.	Check operation of turn signals (para 2-15, item 21). If turn signals do not illuminate, go to step 2. If turn signals are ok, notify Unit Maintenance.
	Step 2.	Check circuit breaker (CB74) in PDP to see if it is tripped.
	(a)	Remove PDP cover (para 3-13a).
	(b)	Position main light switch to OFF (para 2-21c).

Table 3-2. Troubleshooting (Cont)

MALFUNCTION	TEST OR INSPECTION	CORRECTIVE ACTION
e26.	RIGHT TURN SIGNAL INDICATOR DOES NOT ILLUMINATE (CONT).	<ul style="list-style-type: none"> (c) If circuit breaker is tripped, push in to reset. (d) Position main light switch to SER DRIVE (para 2-21c). (e) Check circuit breaker to see if it tripped. If circuit breaker is tripped, notify Unit Maintenance. (f) Position main light switch to OFF (para 2-21c). (g) Install PDP cover (para 3-13b). (h) If right turn signal indicator still does not illuminate, notify Unit Maintenance.
e27.	TURN SIGNAL INDICATORS AND HIGH BEAMS ON INDICATOR DO NOT ILLUMINATE.	<p>Step 1. Check operation of turn signals and high beams (para 2-15, item 21 and 40).</p> <p>If turn signals and headlights are ok, notify Unit Maintenance.</p>
e28.	HIGH BEAMS ON INDICATOR DOES NOT ILLUMINATE.	<p>Step 1. Check operation of high beams (para 2-21c).</p> <p>If high beams do not illuminate, perform Electrical System Troubleshooting (e39. One Or Both Headlights High Beams Do Not Illuminate). If high beams illuminate, notify Unit Maintenance.</p>
e29.	PARKING BRAKE INDICATOR AND/OR EMERGENCY BRAKE INDICATOR DOES NOT ILLUMINATE.	<p>Step 1. Check operation of parking brake (para 2-15, item 19).</p> <p>If parking brakes do not operate, perform Brake System Troubleshooting (i8. Parking Brakes Do Not Apply).</p> <p>Step 2. Check circuit breaker (CB77) in PDP to see if it is tripped.</p> <ul style="list-style-type: none"> (a) Remove PDP cover (para 3-13a). (b) Position main light switch to OFF (para 2-21c). (c) If circuit breaker is tripped, push in to reset. (d) Position main light switch to SER DRIVE (para 2-21c). (e) Check circuit breaker to see if it tripped. If circuit breaker is tripped, notify Unit Maintenance. (f) Position main light switch to OFF (para 2-21c). (g) Install PDP cover (para 3-13b). (h) If parking brake indicator and/or emergency brake indicator still does not illuminate, notify Unit Maintenance.
e30.	POWER TAKE-OFF (PTO) INDICATOR DOES NOT ILLUMINATE.	<p>Step 1. If PTO indicator does not work, go to step 2. If PTO is ok, notify Unit Maintenance.</p>

Table 3-2. Troubleshooting (Cont)

MALFUNCTION	TEST OR INSPECTION	CORRECTIVE ACTION
e. ELECTRICAL SYSTEM (CONT)		
e30.	POWER TAKE-OFF (PTO) INDICATOR DOES NOT ILLUMINATE (CONT).	<p>Step 2. Check circuit breaker (CB49) in PDP to see if it is tripped.</p> <ul style="list-style-type: none"> (a) Remove PDP cover (para 3-13a). (b) Shut down engine (para 2-21f). (c) If circuit breaker is tripped, push in to reset. (d) Engage PTO (para 2-54). (e) Check circuit breaker to see if it tripped. If circuit breaker is tripped, notify Unit Maintenance. (f) Disengage PTO (para 2-54). (g) Install PDP cover (para 3-13b). (h) If PTO indicator still does not illuminate, notify Unit Maintenance.
e31.	FAN OFF INDICATOR DOES NOT ILLUMINATE.	<p>Check circuit breaker (CB22) in PDP to see if it is tripped.</p> <ul style="list-style-type: none"> (a) Remove PDP cover (para 3-13a). (b) Shut down engine (para 2-21f). (c) If circuit breaker is tripped, push in to reset. (d) Start engine (para 2-21a or b). (e) Check circuit breaker to see if it tripped. If circuit breaker is tripped, notify Unit Maintenance. (f) Shut down engine (para 2-21f). (g) Install PDP cover (para 3-13b). (h) If fan off indicator still does not illuminate, notify Unit Maintenance.
e32.	TRANSMISSION TEMPERATURE INDICATOR DOES NOT ILLUMINATE.	<p>Check circuit breaker (CB77) in PDP to see if it is tripped.</p> <ul style="list-style-type: none"> (a) Remove PDP cover (para 3-13a). (b) Shut down engine (para 2-21f). (c) If circuit breaker is tripped, push in to reset. (d) Start engine (para 2-21a or b) and road test vehicle. (e) Check circuit breaker to see if it tripped. If circuit breaker is tripped, notify Unit Maintenance.

Table 3-2. Troubleshooting (Cont)

MALFUNCTION	TEST OR INSPECTION	CORRECTIVE ACTION
e32. TRANSMISSION TEMPERATURE INDICATOR DOES NOT ILLUMINATE (CONT).	<ul style="list-style-type: none"> (f) Shut down engine (para 2-21f). (g) Install PDP cover (para 3-13b). (h) If transmission temperature indicator still does not illuminate, notify Unit Maintenance. 	
e33. FRONT BRAKE AIR INDICATOR DOES NOT ILLUMINATE WHEN AIR PRESSURE IS BELOW 65 PSI.	<p>Step 1. Check to see if other indicator lights illuminate.</p> <ul style="list-style-type: none"> (a) Position master power switch to on (para 2-21a or b). If other indicator lights illuminate then go to step 2 of this fault. If other indicator lights do not illuminate, notify Unit Maintenance. (b) Position master power switch to off (para 2-21f). <p>Step 2. Check operation of FRONT AIR BRAKE pressure gage.</p> <ul style="list-style-type: none"> (a) Start engine (para 2-21a or b) and allow vehicle to build air pressure. If FRONT BRAKE AIR pressure gage operates, notify Unit Maintenance. If FRONT BRAKE AIR pressure gage does not operate, perform Electrical System Troubleshooting (e9. Front Brake Air Pressure Gage Does Not Operate Or Is Inaccurate). (b) Shut down engine (para 2-21f). 	
e34. REAR BRAKE AIR INDICATOR DOES NOT ILLUMINATE WHEN AIR PRESSURE IS BELOW 65 PSI.	<p>Step 1. Check to see if other indicator lights illuminate.</p> <ul style="list-style-type: none"> (a) Position master power switch to on (para 2-21a or b). If other indicator lights illuminate then go to step 2 of this fault. If other indicator lights do not illuminate, notify Unit Maintenance. (b) Position master power switch to off (para 2-21f). <p>Step 2. Check operation of REAR AIR BRAKE pressure gage.</p> <ul style="list-style-type: none"> (a) Position master power switch to on (para 2-21a or b). (b) Start engine (para 2-21a or b) and allow vehicle to build air pressure. If REAR BRAKE AIR pressure gage operates, notify Unit Maintenance. If REAR BRAKE AIR pressure gage does not operate, perform Electrical System Troubleshooting (e8. Rear Brake Air Pressure Gage Does Not Operate Or Is Inaccurate). (c) Shut down engine (para 2-21f). 	

Table 3-2. Troubleshooting (Cont)

MALFUNCTION	TEST OR INSPECTION	CORRECTIVE ACTION
e. ELECTRICAL SYSTEM (CONT)		
e35. ENGINE OIL PRESSURE INDICATOR DOES NOT OPERATE.	Check circuit breaker (CB77) in PDP to see if it is tripped.	<ul style="list-style-type: none"> (a) Remove PDP cover (para 3-13a). (b) Shut down engine (para 2-21f). (c) If circuit breaker is tripped, push in to reset. (d) Start engine (2-21a or b). (e) Check circuit breaker to see if it tripped. If circuit breaker is tripped, notify Unit Maintenance. (f) Shut down engine (para 2-21f). (g) Install PDP cover (para 3-13b). (h) If engine oil pressure indicator still does not illuminate, notify Unit Maintenance.
e36. MASTER STOP INDICATOR DOES NOT ILLUMINATE.	Check circuit breaker (CB77) in PDP to see if it is tripped.	<ul style="list-style-type: none"> (a) Remove PDP cover (para 3-13a). (b) Shut down engine (para 2-21f). (c) If circuit breaker is tripped, push in to reset. (d) Start engine (para 2-21a or b). (e) Check circuit breaker to see if it tripped. If circuit breaker is tripped, notify Unit Maintenance. (f) Shut down engine (para 2-21f). (g) Install PDP cover (para 3-13b). (h) If master stop indicator still does not illuminate, notify Unit Maintenance.
e37. ONE OR BOTH HEADLIGHTS (HIGH AND LOW BEAMS) DO NOT ILLUMINATE.	<p>Step 1. Check operation of all vehicle lights (para 2-21c).</p> <p>If either light is not illuminating, notify Unit Maintenance.</p>	<p>Step 2. Check circuit breaker (CB78) in PDP to see if they are tripped.</p> <ul style="list-style-type: none"> (a) Remove PDP cover (para 3-13a). (b) Position main light switch to OFF (para 2-21c). (c) If circuit breakers are tripped, push in to reset.

Table 3-2. Troubleshooting (Cont)

MALFUNCTION	TEST OR INSPECTION	CORRECTIVE ACTION
e37. ONE OR BOTH HEADLIGHTS (HIGH AND LOW BEAMS) DO NOT ILLUMINATE (CONT).	<ul style="list-style-type: none"> (d) Position main light switch to SER DRIVE (para 2-21c). (e) Check circuit breakers to see if they tripped. If circuit breaker is tripped, notify Unit Maintenance. (f) Position main light switch to OFF (para 2-21c). (g) Install PDP cover (para 3-13b). (h) If one or both headlights still do not illuminate, notify Unit Maintenance. 	
e38. ONE OR BOTH HEADLIGHT LOW BEAMS DO NOT ILLUMINATE.	<p>Check operation of all vehicle lights (para 2-21c).</p> <p>If either light is not illuminating, notify Unit Maintenance.</p>	
e39. ONE OR BOTH HEADLIGHT HIGH BEAMS DO NOT ILLUMINATE.	<p>Check operation of all vehicle lights (para 2-21c).</p> <p>If either light is not illuminating, notify Unit Maintenance.</p>	
e40. PARKING LIGHTS DO NOT ILLUMINATE.	<p>Step 1. Check operation of all vehicle lights (para 2-21c).</p> <p>If either light is not illuminating, notify Unit Maintenance.</p> <p>Step 2. Check circuit breaker (CB65) in PDP to see if it is tripped.</p> <ul style="list-style-type: none"> (a) Remove PDP cover (para 3-13a). (b) Position main light switch to OFF (para 2-21c). (c) If circuit breaker is tripped, push in to reset. (d) Position main light switch to SER DRIVE (para 2-21c). (e) Check circuit breaker to see if it tripped. If circuit breaker is tripped, notify Unit Maintenance. (f) Position main light switch to OFF (para 2-21c). (g) Install PDP cover (para 3-13b). (h) If parking lights still do not illuminate, notify Unit Maintenance. 	
e41. LH DOOR AND/OR LH FRONT MARKER LIGHTS DO NOT ILLUMINATE.	<p>Check operation of all marker lights (para 2-21c)</p> <p>If all marker lights do not illuminate, perform Electrical System Troubleshooting (e44a. All Marker Lights Do Not Illuminate In Normal Model). If LH door and/or LH front marker lights do not illuminate, notify Unit Maintenance.</p>	

Table 3-2. Troubleshooting (Cont)

MALFUNCTION
TEST OR INSPECTION
CORRECTIVE ACTION
<p>e. ELECTRICAL SYSTEM (CONT)</p>
<p>e42. RH DOOR AND/OR RH FRONT MARKER LIGHTS DO NOT ILLUMINATE.</p>
<p>Check operation of all marker lights (para 2-21c).</p> <p>If all marker lights do not illuminate, perform Electrical System Troubleshooting (e44a. All Marker Lights Do Not Illuminate In Normal Model). If RH door and/or RH front marker lights do not illuminate, notify Unit Maintenance.</p>
<p>e43. ONE OR MORE CAB TOP MARKER LIGHTS DO NOT ILLUMINATE.</p>
<p>Check operation of all marker lights (para 2-21c).</p> <p>If all marker lights do not illuminate, perform Electrical System Troubleshooting (e44a. All Marker Lights Do Not Illuminate In Normal Model). If one or more cab top marker lights do not illuminate, notify Unit Maintenance.</p>
<p>e44. SIDE AND/OR REAR MARKER LIGHT(S) DO NOT ILLUMINATE.</p>
<p>Check operation of all marker lights (para 2-21c).</p> <p>If all marker lights do not illuminate, perform Electrical System Troubleshooting (e44a. All Marker Lights Do Not Illuminate In Normal Model). If side and/or rear marker lights do not illuminate, notify Unit Maintenance.</p>
<p>e44a. ALL MARKER LIGHTS DO NOT OPERATE IN NORMAL MODE.</p>
<p>Check circuit breaker (CB67) in Power Distribution Panel (PDP) to see if it is tripped.</p> <ul style="list-style-type: none"> (a) Remove PDP cover (para 3-13a). (b) Check circuit breaker (CB67) to see if it is tripped. If circuit breaker (CB67) is tripped, push in to reset. (c) Position main light switch to SER DRIVE (para 2-21c). (d) If all marker lights still do not illuminate, check circuit breaker (CB67) to see if it is tripped. If circuit breaker is tripped, notify Unit Maintenance. (e) Install PDP cover (para 3-13b). (f) Position main light switch to OFF (para 2-21c). (g) If all marker lights do not illuminate, notify Unit Maintenance.
<p>e45. ONE OR BOTH COMPOSITE TAILLIGHTS DO NOT ILLUMINATE.</p>
<p>Step 1. Check to see if other service light illuminates.</p> <p>If either light is not illuminating, notify Unit Maintenance.</p>

Table 3-2. Troubleshooting (Cont)

MALFUNCTION
TEST OR INSPECTION
CORRECTIVE ACTION
<p>e45. ONE OR BOTH COMPOSITE TAILLIGHTS DO NOT ILLUMINATE (CONT).</p> <p>Step 2. Check circuit breakers (CB43, CB44, and CB67) in PDP to see if they are tripped.</p> <ul style="list-style-type: none"> (a) Remove PDP cover (para 3-13c). (b) Position main light switch to OFF (para 2-21c). (c) If circuit breakers are tripped, push in to reset. (d) Position main light switch to SER DRIVE (para 2-21c). (e) Check circuit breakers to see if they are tripped. If circuit breaker is tripped, notify Unit Maintenance. (f) Position main light switch to OFF (para 2-21c). (g) Install PDP cover (para 3-13b). (h) If one or both composite taillights still do not illuminate, notify Unit Maintenance. <p>e46. ONE OR BOTH FRONT BLACKOUT MARKER LIGHTS DO NOT ILLUMINATE.</p> <p>Step 1. Check operation of all vehicle lights (para 2-21c).</p> <p>If either light is not illuminating, notify Unit Maintenance.</p> <p>Step 2. Check circuit breaker (CB66) in PDP to see if it is tripped.</p> <ul style="list-style-type: none"> (a) Remove PDP cover (para 3-13a). (b) Position main light switch to OFF (para 2-21c). (c) If circuit breaker is tripped, push in to reset. (d) Position main light switch to SER DRIVE (para 2-21c). (e) Check circuit breaker to see if it tripped. If circuit breaker is tripped, notify Unit Maintenance. (f) Position main light switch to OFF (para 2-21c). (g) Install PDP cover (para 3-13b). (h) If one or both front blackout marker lights still do not illuminate, notify Unit Maintenance. <p>e47. BLACKOUT DRIVE LIGHT DOES NOT ILLUMINATE.</p> <p>Step 1. Check operation of all vehicle lights (para 2-21c).</p> <p>If either light is not illuminating, notify Unit Maintenance.</p>

Table 3-2. Troubleshooting (Cont)

MALFUNCTION
TEST OR INSPECTION
CORRECTIVE ACTION
<p>e. ELECTRICAL SYSTEM (CONT)</p>
<p>e47. BLACKOUT DRIVE LIGHT DOES NOT ILLUMINATE (CONT).</p>
<p>Step 2. Check circuit breakers (CB54 and CB66) in PDP to see if they are tripped.</p>
<p>(a) Remove PDP cover (para 3-13a).</p>
<p>(b) Position main light switch to OFF (para 2-21c).</p>
<p>(c) If circuit breakers are tripped, push in to reset.</p>
<p>(d) Position main light switch to SER DRIVE (para 2-21c).</p>
<p>(e) Check circuit breakers to see if they tripped. If circuit breaker is tripped, notify Unit Maintenance.</p>
<p>(f) Position main light switch to OFF (para 2-21c).</p>
<p>(g) Install PDP cover (para 3-13b).</p>
<p>(h) If blackout drive light still does not illuminate, notify Unit Maintenance.</p>
<p>e48. ONE OR BOTH REAR BLACKOUT MARKER LIGHTS DO NOT ILLUMINATE.</p>
<p>Step 1. Check operation of all vehicle lights (para 2-21c).</p>
<p>If either light is not illuminating, notify Unit Maintenance.</p>
<p>Step 2. Check circuit breaker (CB66) in PDP to see if it is tripped.</p>
<p>(a) Remove PDP cover (para 3-13a).</p>
<p>(b) Position main light switch to OFF (para 2-21c).</p>
<p>(c) If circuit breaker is tripped, push in to reset.</p>
<p>(d) Position main light switch to SER DRIVE (para 2-21c).</p>
<p>(e) Check circuit breaker to see if it tripped. If circuit breaker is tripped, notify Unit Maintenance.</p>
<p>(f) Position main light switch to OFF (para 2-21c).</p>
<p>(g) Install PDP cover (para 3-13b).</p>
<p>(h) If one or more rear blackout marker lights still do not illuminate, notify Unit Maintenance.</p>
<p>e49. WARNING LIGHT DOES NOT ILLUMINATE.</p>
<p>Step 1. Check operation of all vehicle lights (para 2-21c).</p>
<p>If either light is not illuminating, notify Unit Maintenance.</p>

Table 3-2. Troubleshooting (Cont)

MALFUNCTION
TEST OR INSPECTION
CORRECTIVE ACTION
<p>e49. WARNING LIGHT DOES NOT ILLUMINATE (CONT).</p> <p>Step 2. Check circuit breaker (CB38) in PDP to see if it is tripped.</p> <ul style="list-style-type: none"> (a) Remove PDP cover (para 3-13a). (b) Position main light switch to OFF (para 2-21c). (c) If circuit breaker is tripped, push in to reset. (d) Position main light switch to SER DRIVE (para 2-21c). (e) Check circuit breaker to see if it tripped. If circuit breaker is tripped, notify Unit Maintenance. (f) Position main light switch to OFF (para 2-21c). (g) Install PDP cover (para 3-13b). (h) If warning light still does not illuminate, notify Unit Maintenance. <p>e50. BACKUP LIGHT DOES NOT ILLUMINATE.</p> <p>Step 1. Check operation of all vehicle lights (para 2-21c).</p> <p>If either light is not illuminating, notify Unit Maintenance.</p> <p>Step 2. Check circuit breakers (CB73 and CB70) in PDP to see if it is tripped.</p> <ul style="list-style-type: none"> (a) Remove PDP cover (para 3-13a). (b) Position main light switch to OFF (para 2-21c). (c) If circuit breaker(s) is tripped, push in to reset. (d) Position main light switch to SER DRIVE (para 2-21c). (e) Check circuit breaker(s) to see if they tripped. If circuit breaker(s) tripped, notify Unit Maintenance. (f) Position main light switch to OFF (para 2-21c). (g) Install PDP cover (para 3-13b). (h) If backup light still does not illuminate, notify Unit Maintenance. <p>e51. BLACKOUT MARKER LIGHTS DO NOT ILLUMINATE.</p> <p>Step 1. Check operation of all vehicle lights (para 2-21c).</p> <p>If either light is not illuminating, notify Unit Maintenance.</p> <p>Step 2. Check circuit breaker (CB66) in PDP to see if it is tripped.</p> <ul style="list-style-type: none"> (a) Remove PDP cover (para 3-13a). (b) Position main light switch to OFF (para 2-21c). (c) If circuit breaker is tripped, push in to reset.

Table 3-2. Troubleshooting (Cont)

MALFUNCTION	TEST OR INSPECTION	CORRECTIVE ACTION
e. ELECTRICAL SYSTEM (CONT)		
e51.	BLACKOUT MARKER LIGHTS DO NOT ILLUMINATE (CONT).	<ul style="list-style-type: none"> (d) Position main light switch to SER DRIVE (para 2-21c). (e) Check circuit breaker to see if it tripped. If circuit breaker is tripped, notify Unit Maintenance. (f) Position main light switch to OFF (para 2-21c). (g) Install PDP cover (para 3-13b). (h) If blackout marker lights still do not illuminate, notify Unit Maintenance.
e51a.	FRONT HAZARD LIGHTS DO NOT ILLUMINATE.	<p>Step 1. Check operation of front and rear turn signals (para 2-21c).</p> <p>If front and rear turn signals do not illuminate, perform Electrical System Troubleshooting (e53. Front and Rear hazard Lights Do Not Illuminate).</p> <p>Step 2. Check operation of rear hazard lights (para 2-21c).</p> <ul style="list-style-type: none"> (a) If rear hazard lights do not illuminate, perform Electrical System Troubleshooting (e53. Front and Rear Hazard Lights Do Not Illuminate). (b) If front hazard lights do not illuminate, notify Unit Maintenance.
e52.	REAR HAZARD LIGHTS DO NOT ILLUMINATE.	<p>Step 1. Check operation of all vehicle lights (para 2-21c).</p> <p>If either light does not illuminate, notify Unit Maintenance.</p> <p>Step 2. Check circuit breaker (CB71) in PDP to see if it is tripped.</p> <ul style="list-style-type: none"> (a) Remove PDP cover (para 3-13a). (b) Position main light switch to OFF (para 2-21c). (c) If circuit breaker is tripped, push in to reset. (d) Position main light switch to SER DRIVE (para 2-21c). (e) Check circuit breaker to see if it tripped. If circuit breaker is tripped, notify Unit Maintenance. (f) Position main light switch to OFF (para 2-21c). (g) Install PDP cover (para 3-13b). (h) If rear hazard lights still do not illuminate, notify Unit Maintenance.
e53.	FRONT AND REAR HAZARD LIGHTS DO NOT ILLUMINATE.	<p>Step 1. Check operation of front and rear turn signals (para 2-21c).</p>

Table 3-2. Troubleshooting (Cont)

MALFUNCTION	TEST OR INSPECTION	CORRECTIVE ACTION
e53. FRONT AND REAR HAZARD LIGHTS DO NOT ILLUMINATE (CONT).	<ul style="list-style-type: none"> (a) If front and rear turn signals do not illuminate, perform Electrical System Troubleshooting (e54. Front and Rear Turn Signals Do Not Illuminate). (b) If left or right front turn signal does not illuminate, perform Electrical System Troubleshooting (e55. Left Or Right Front Turn Signal Does Not Illuminate). (c) If turn signals illuminate, go to step 2 of this fault. 	<p>Step 2. Check circuit breakers (CB71 and CB74) in PDP to see if it is tripped.</p> <ul style="list-style-type: none"> (a) Position main light switch to OFF (para 2-21c). (b) Remove PDP cover (para 3-13a). (c) Check circuit breakers (CB71 and CB74) to see if they are tripped. (d) If circuit breaks (CB71 and CB74) are tripped, push in to reset. (e) Install PDP cover (para 3-13b). (f) Position main light switch to SER DRIVE (para 2-21c). (g) Position hazard lights switch to on (para 2-21c). (h) If front and rear hazard lights still do not illuminate, notify Unit Maintenance. (i) Position hazard lights switch to OFF (para 2-21c). (j) Position main light switch to OFF (para 2-21c).
e54. FRONT AND REAR TURN SIGNALS DO NOT ILLUMINATE.	<p>Step 1. Check operation of all vehicle lights (para 2-21c).</p> <p>If either light does not illuminate, notify Unit Maintenance.</p>	<p>Step 2. Check circuit breaker (CB74) in PDP to see if it is tripped.</p> <ul style="list-style-type: none"> (a) Remove PDP cover (para 3-13a). (b) Position main light switch to OFF (para 2-21c). (c) If circuit breaker is tripped, push in to reset. (d) Position main light switch to SER DRIVE (para 2-21c). (e) Check circuit breaker to see if it tripped. If circuit breaker is tripped, notify Unit Maintenance. (f) Position main light switch to OFF (para 2-21c). (g) Install PDP cover (para 3-13b). (h) If front and rear turn signals still do not illuminate, notify Unit Maintenance.

Table 3-2. Troubleshooting (Cont)

MALFUNCTION
TEST OR INSPECTION
CORRECTIVE ACTION
e. ELECTRICAL SYSTEM (CONT)
<p>e55. LEFT OR RIGHT FRONT TURN SIGNAL DOES NOT ILLUMINATE.</p> <p>Step 1. Check operation of all vehicle lights (para 2-21c).</p> <p style="padding-left: 20px;">If either light does not illuminate, notify Unit Maintenance.</p> <p>Step 2. Check circuit breaker (CB74) in PDP to see if it is tripped.</p> <ul style="list-style-type: none"> (a) Remove PDP cover (para 3-13a). (b) Position main light switch to OFF (para 2-21c). (c) If circuit breaker is tripped, push in to reset. (d) Position main light switch to SER DRIVE (para 2-21c). (e) Check circuit breaker to see if it tripped. If circuit breaker is tripped, notify Unit Maintenance. (f) Position main light switch to OFF (para 2-21c). (g) Install PDP cover (para 3-13b). (h) If left or right front turn signal still does not illuminate, notify Unit Maintenance. <p>e56. ONE OR BOTH STOPLIGHTS DO NOT ILLUMINATE.</p> <p>Step 1. Check operation of all vehicle lights (para 2-21c).</p> <p style="padding-left: 20px;">If stoplights and blackout stoplights do not illuminate, perform Electrical System Troubleshooting (e58. Stoplights and Blackout Stoplights Do Not Illuminate). If both stoplights do not illuminate, notify Unit Maintenance.</p> <p>Step 2. Check circuit breakers (CB43, CB44, and CB76) in PDP to see if they are tripped.</p> <ul style="list-style-type: none"> (a) Remove PDP cover (para 3-13a). (b) Position main light switch to OFF (para 2-21c). (c) If circuit breakers are tripped, push in to reset. (d) Position main light switch to SER DRIVE (para 2-21c). (e) Check circuit breaker to see if it tripped. If circuit breaker is tripped, notify Unit Maintenance. (f) Position main light switch to OFF (para 2-21c). (g) Install PDP cover (para 3-13b). (h) If one or both stoplights do not illuminate, notify Unit Maintenance. <p>e57. ONE OR BOTH BLACKOUT STOPLIGHTS DO NOT OPERATE.</p> <p>Step 1. Check operation of all vehicle lights (para 2-21c).</p> <p style="padding-left: 20px;">If either light is not illuminating, notify Unit Maintenance.</p>

Table 3-2. Troubleshooting (Cont)

MALFUNCTION	TEST OR INSPECTION	CORRECTIVE ACTION
e57. ONE OR BOTH BLACKOUT STOPLIGHTS DO NOT OPERATE (CONT).	Step 2. Check circuit breaker (CB76) in PDP to see if it is tripped.	<ul style="list-style-type: none"> (a) Remove PDP cover (para 3-13a). (b) Position main light switch to OFF (para 2-21c). (c) If circuit breaker is tripped, push in to reset. (d) Position main light switch to SER DRIVE (para 2-21c). (e) Check circuit breaker to see if it tripped. If circuit breaker is tripped, notify Unit Maintenance. (f) Position main light switch to OFF (para 2-21c). (g) Install PDP cover (para 3-13b). (h) If one or both blackout stoplights still do not illuminate, notify Unit Maintenance.
e58. STOPLIGHTS AND BLACKOUT STOPLIGHTS DO NOT ILLUMINATE.	Step 1. Check operation of all vehicle lights (para 2-21c). If either light does not illuminate, notify Unit Maintenance.	
	Step 2. Check circuit breaker (CB76) in PDP to see if it is tripped.	<ul style="list-style-type: none"> (a) Remove PDP cover (para 3-13a). (b) Position main light switch to OFF (para 2-21c). (c) If circuit breaker is tripped, push in to reset. (d) Position main light switch to SER DRIVE (para 2-21c). (e) Check circuit breaker to see if it tripped. If circuit breaker is tripped, notify Unit Maintenance. (f) Position main light switch to OFF (para 2-21c). (g) Install PDP cover (para 3-13b). (h) If stoplights and blackout stoplights still do not illuminate, notify Unit Maintenance.
e59. TRAILER MARKER/TAILLIGHTS DO NOT ILLUMINATE.	Notify Unit Maintenance.	
e60. TRAILER RIGHT STOP/TURN LIGHT DOES NOT ILLUMINATE.	Notify Unit Maintenance.	
e61. TRAILER LEFT STOP/TURN LIGHT DOES NOT ILLUMINATE.	Notify Unit Maintenance.	

Table 3-2. Troubleshooting (Cont)

MALFUNCTION	TEST OR INSPECTION	CORRECTIVE ACTION
e. ELECTRICAL SYSTEM (CONT)		
e62.	TRAILER BLACKOUT MARKER LIGHTS DO NOT ILLUMINATE.	Notify Unit Maintenance.
e63.	TRAILER BLACKOUT STOPLIGHTS DO NOT ILLUMINATE.	Notify Unit Maintenance.
e64.	INTERVEHICLE CLEARANCE LIGHTS DO NOT ILLUMINATE.	Notify Unit Maintenance.
e65.	INTERVEHICLE LEFT TURN SIGNAL DOES NOT ILLUMINATE.	Notify Unit Maintenance.
e66.	INTERVEHICLE RIGHT TURN SIGNAL DOES NOT ILLUMINATE.	Notify Unit Maintenance.
e67.	INTERVEHICLE STOPLIGHTS DO NOT ILLUMINATE.	Notify Unit Maintenance.
e68.	INTERVEHICLE TAILLIGHTS DO NOT ILLUMINATE.	Notify Unit Maintenance.
e69.	PERSONNEL HEATER CONTROL ILLUMINATION DOES NOT OPERATE.	<p>Step 1. Check operation of all vehicle lights (para 2-21c).</p> <p>If either light is not illuminating, notify Unit Maintenance.</p> <p>Step 2. Check circuit breaker (CB23) in PDP to see if it is tripped.</p> <ul style="list-style-type: none"> (a) Remove PDP cover (para 3-13a). (b) Position main light switch to OFF (para 2-21c). (c) If circuit breaker is tripped, push in to reset. (d) Position main light switch to SER DRIVE (para 2-21c). (e) Check circuit breaker to see if it tripped. If circuit breaker is tripped, notify Unit Maintenance. (f) Position main light switch to OFF (para 2-21c). (g) Install PDP cover (para 3-13b). (h) If personnel heater control illumination still does not operate, notify Unit Maintenance.

Table 3-2. Troubleshooting (Cont)

MALFUNCTION
TEST OR INSPECTION
CORRECTIVE ACTION
<p>e70. PERSONNEL HEATER FAN DOES NOT OPERATE.</p> <p>Check circuit breaker (CB23) in PDP to see if it is tripped.</p> <ul style="list-style-type: none"> (a) Remove PDP cover (para 3-13a). (b) Position master power switch to off (para 2-21f). (c) If circuit breaker is tripped, push in to reset. (d) Position master power switch to on (para 2-21a or b). (e) Check circuit breaker in PDP to see if it is tripped. If circuit breaker is tripped, notify Unit Maintenance. (f) Position master power switch to off (para 2-21f). (g) Install PDP cover (para 3-13b). (h) If personnel heater fan still does not operate, notify Unit Maintenance. <p>e71. WINDSHIELD WASHER DOES NOT OPERATE.</p> <p>Check circuit breaker (CB37) in PDP to see if it is tripped.</p> <ul style="list-style-type: none"> (a) Remove PDP cover (para 3-13a). (b) Position master power switch to off (para 2-21f). (c) If circuit breaker is tripped, push in to reset. (d) Position master power switch to on (para 2-21a or b). (e) Check circuit breaker to see if it tripped. If circuit breaker is tripped, notify Unit Maintenance. (f) Position master power switch to off (para 2-21f). (g) Install PDP cover (para 3-13b). (h) If windshield washer still does not operate, notify Unit Maintenance. <p>e72. WINDSHIELD WIPER DOES NOT OPERATE ON LOW SPEED.</p> <p>Check circuit breaker (CB37) in PDP to see if it is tripped.</p> <ul style="list-style-type: none"> (a) Remove PDP cover (para 3-13a). (b) Position master power switch to off (para 2-21f). (c) If circuit breaker is tripped, push in to reset. (d) Position master power switch to on (para 2-21a or b). (e) Check circuit breaker to see if it tripped. If circuit breaker is tripped, notify Unit Maintenance.

Table 3-2. Troubleshooting (Cont)

MALFUNCTION	TEST OR INSPECTION	CORRECTIVE ACTION
e. ELECTRICAL SYSTEM (CONT)		
e72.	WINDSHIELD WIPER DOES NOT OPERATE ON LOW SPEED (CONT).	<ul style="list-style-type: none"> (f) Position master power switch to off (para 2-21f). (g) Install PDP cover (para 3-13b). (h) If windshield wiper still does not operate, notify Unit Maintenance.
e73.	ALL WINDSHIELD WIPER SPEEDS DO NOT OPERATE.	<p>Check circuit breaker (CB37) in PDP to see if it is tripped.</p> <ul style="list-style-type: none"> (a) Remove PDP cover (para 3-13a). (b) Position master power switch to off (para 2-21f). (c) If circuit breaker is tripped, push in to reset. (d) Position master power switch to on (para 2-21a or b). (e) Check circuit breaker to see if it tripped. If circuit breaker is tripped, notify Unit Maintenance. (f) Position master power switch to off (para 2-21f). (g) Install PDP cover (para 3-13b). (h) If all windshield wiper speeds still does not operate, notify Unit Maintenance.
e74.	WINDSHIELD WIPER SPEED DOES NOT OPERATE ON INTERMITTENT SPEED.	<p>Check circuit breaker (CB37) in PDP to see if it is tripped.</p> <ul style="list-style-type: none"> (a) Remove PDP cover (para 3-13a). (b) Position master power switch to off (para 2-21f). (c) If circuit breaker is tripped, push in to reset. (d) Position master power switch to on (para 2-21a or b). (e) Check circuit breaker to see if it tripped. If circuit breaker is tripped, notify Unit Maintenance. (f) Position master power switch to off (para 2-21f). (g) Install PDP cover (para 3-13b). (h) If windshield wiper speed still does not operate on intermittent speed, notify Unit Maintenance.

Table 3-2. Troubleshooting (Cont)

MALFUNCTION
TEST OR INSPECTION
CORRECTIVE ACTION
<p>e75. WINDSHIELD WIPER DOES NOT OPERATE ON HIGH SPEED.</p> <p>Check circuit breaker (CB37) in PDP to see if it is tripped.</p> <ul style="list-style-type: none"> (a) Remove PDP cover (para 3-13a). (b) Position master power switch to off (para 2-21f). (c) If circuit breaker is tripped, push in to reset. (d) Position master power switch to on (para 2-21a or b). (e) Check circuit breaker to see if it tripped. If circuit breaker is tripped, notify Unit Maintenance. (f) Position master power switch to off (para 2-21f). (g) Install PDP cover (para 3-13b). (h) If windshield wiper speed still does not operate on high speed, notify Unit Maintenance.
<p>e76. HORN DOES NOT OPERATE.</p> <p>Check circuit breaker (CB36) in PDP to see if it is tripped.</p> <ul style="list-style-type: none"> (a) Remove PDP cover (para 3-13a). (b) Position master power switch to off (para 2-21f). (c) If circuit breaker is tripped, push in to reset. (d) Position master power switch to on (para 2-21a or b). (e) Check circuit breaker to see if it tripped. If circuit breaker is tripped, notify Unit Maintenance. (f) Position master power switch to off (para 2-21f). (g) Install PDP cover (para 3-13b). (h) If horn still does not operate, notify Unit Maintenance.
<p>e77. CHEMICAL ALARM DOES NOT OPERATE.</p> <p>Check circuit breaker (CB30) in PDP panel to see if it is tripped.</p> <ul style="list-style-type: none"> (a) Remove PDP cover (para 3-13a). (b) Position master power switch to off (para 2-21f). (c) If circuit breaker is tripped, push in to reset. (d) Position master power switch to on (para 2-21a or b). (e) Check circuit breaker to see if it tripped. If circuit breaker is tripped, notify Unit Maintenance.

Table 3-2. Troubleshooting (Cont)

MALFUNCTION	TEST OR INSPECTION	CORRECTIVE ACTION
e. ELECTRICAL SYSTEM (CONT)		
e77.	CHEMICAL ALARM DOES NOT OPERATE (CONT).	<ul style="list-style-type: none"> (f) Install PDP cover (para 3-13b). (g) If chemical alarm still does not operate, notify Unit Maintenance.
e78.	CHEMICAL DETECTOR DOES NOT OPERATE.	<p>Check circuit breaker (CB30) in PDP to see if it is tripped.</p> <ul style="list-style-type: none"> (a) Remove PDP cover (para 3-13a). (b) Position master power switch to off (para 2-21f). (c) If circuit breaker is tripped, push in to reset. (d) Position master power switch to on (para 2-21a or b). (e) Check circuit breaker to see if it tripped. If circuit breaker is tripped, notify Unit Maintenance. (f) Position master power switch to off (para 2-21f). (g) Install PDP cover (para 3-13b). (h) If chemical detector still does not operate, notify Unit Maintenance.
e79.	CENTRAL TIRE INFLATION SYSTEM (CTIS) DOES NOT OPERATE.	<p>Check circuit breaker (CB40) in PDP to see if it is tripped.</p> <ul style="list-style-type: none"> (a) Remove PDP cover (para 3-13a). (b) Position master power switch to off (para 2-21f). (c) If circuit breaker is tripped, push in to reset. (d) Position master power switch to on (para 2-21a or b). (e) Check circuit breaker to see if it tripped. If circuit breaker is tripped, notify Unit Maintenance. (f) Position master power switch to off (para 2-21f). (g) Install PDP cover (para 3-13b). (h) If CTIS still does not operate, notify Unit Maintenance.
e80.	CENTRAL TIRE INFLATION SYSTEM (CTIS) DOES NOT INFLATE TIRES.	<p>Step 1. Check operation of CTIS to deflate tires (para 2-23).</p> <p>If CTIS does not deflate tires, notify Unit Maintenance.</p>

Table 3-2. Troubleshooting (Cont)

MALFUNCTION
TEST OR INSPECTION
CORRECTIVE ACTION
<p>e80. CENTRAL TIRE INFLATION SYSTEM (CTIS) DOES NOT INFLATE TIRES (CONT).</p>
<p>Step 2. Check circuit breaker (CB40) in PDP to see if it is tripped.</p>
<ul style="list-style-type: none"> (a) Remove PDP cover (para 3-13a). (b) Position master power switch to off (para 2-21f). (c) If circuit breaker is tripped, push in to reset. (d) Position master power switch to on (para 2-21a or b). (e) Check circuit breaker to see if it tripped. If circuit breaker is tripped, notify Unit Maintenance. (f) Position master power switch to off (para 2-21f). (g) Install PDP cover (para 3-13b). (h) If CTIS still does not inflate tires, notify Unit Maintenance.
<p>e81. CENTRAL TIRE INFLATION SYSTEM (CTIS) DOES NOT DEFLATE TIRES.</p>
<p>Step 1. Check operation of CTIS to inflate tires (para 2-23).</p>
<p>If CTIS does not inflate tires, notify Unit Maintenance.</p>
<p>Step 2. Check circuit breaker (CB40) in PDP to see if it is tripped.</p>
<ul style="list-style-type: none"> (a) Remove PDP cover (para 3-13a). (b) Position master power switch to off (para 2-21f). (c) If circuit breaker is tripped, push in to reset. (d) Position master power switch to on (para 2-21a or b). (e) Check circuit breaker to see if it tripped. If circuit breaker is tripped, notify Unit Maintenance. (f) Install PDP cover (para 3-13b). (g) Position master power switch to off (para 2-21f). (h) If CTIS still does not deflate tires, notify Unit Maintenance.
<p>e82. 11K SELF-RECOVERY WINCH (SRW) DOES NOT REEL IN OR PAY OUT.</p>
<p>Check circuit breaker (CB49) in PDP to see if it is tripped.</p>
<ul style="list-style-type: none"> (a) Remove PDP cover (para 3-13a). (b) Position master power switch to off (para 2-21f). (c) If circuit breaker is tripped, push in to reset. (d) Position master power switch to on (para 2-21a or b).

Table 3-2. Troubleshooting (Cont)

MALFUNCTION	TEST OR INSPECTION	CORRECTIVE ACTION
e. ELECTRICAL SYSTEM (CONT)		
e82.	11K SELF-RECOVERY WINCH (SRW) DOES NOT REEL IN OR PAY OUT (CONT).	<ul style="list-style-type: none"> (e) Check circuit breaker to see if it tripped. If circuit breaker is tripped, notify Unit Maintenance. (f) Position master power switch to off (para 2-21f). (g) Install PDP cover (para 3-13b). (h) If 11K SRW still does not reel in or pay out, notify Unit Maintenance.
e83.	11K SELF-RECOVERY WINCH (SRW) DOES NOT REEL IN.	<p>Check circuit breaker (CB49) in PDP to see if it is tripped.</p> <ul style="list-style-type: none"> (a) Remove PDP cover (para 3-13a). (b) Position master power switch to off (para 2-21f). (c) If circuit breaker is tripped, push in to reset. (d) Position master power switch to on (para 2-21a or b). (e) Check circuit breaker to see if it tripped. If circuit breaker is tripped, notify Unit Maintenance. (f) Position master power switch to off (para 2-21f). (g) Install PDP cover (para 3-13b). (h) If 11K SRW still does not reel in, notify Unit Maintenance.
e84.	11K SELF-RECOVERY WINCH (SRW) DOES NOT PAY OUT.	<p>Check circuit breaker (CB49) in PDP to see if it is tripped.</p> <ul style="list-style-type: none"> (a) Remove PDP cover (para 3-13a). (b) Position master power switch to off (para 2-21f). (c) If circuit breaker is tripped, push in to reset. (d) Position master power switch to on (para 2-21a or b). (e) Check circuit breaker to see if it tripped. If circuit breaker is tripped, notify Unit Maintenance. (f) Position master power switch to off (para 2-21f). (g) Install PDP cover (para 3-13b). (h) If 11K SRW still does not pay out, notify Unit Maintenance.

Table 3-2. Troubleshooting (Cont)

MALFUNCTION
TEST OR INSPECTION
CORRECTIVE ACTION
<p>e85. POWER TAKE-OFF (PTO) DOES NOT OPERATE.</p> <p>Check circuit breaker (CB49) in PDP to see if it is tripped.</p> <ul style="list-style-type: none"> (a) Remove PDP cover (para 3-13a). (b) Position master power switch to off (para 2-21f). (c) If circuit breaker is tripped, push in to reset. (d) Position master power switch to on (para 2-21a or b). (e) Check circuit breaker to see if it tripped. If circuit breaker is tripped, notify Unit Maintenance. (f) Position master power switch to off (para 2-21f). (g) Install PDP cover (para 3-13b). (h) If PTO still does not operate, notify Unit Maintenance. <p>e86. ELECTRICAL SYSTEM DOES NOT MAINTAIN A CHARGE.</p> <p>Step 1. Check to see if battery cables and terminal posts are OK.</p> <ul style="list-style-type: none"> (a) Remove battery box cover (para 3-8a). (b) Check battery cables for apparent damage and corrosion. If corrosion is present or battery cables are damaged, notify Unit Maintenance. (c) Check terminal posts for corrosion. If corrosion is present, notify Unit Maintenance. <p>Step 2. Check fluid level in battery cells (para 3-8b). If fluid level is low, notify Unit Maintenance.</p> <ul style="list-style-type: none"> (a) Install battery box cover (para 3-8c). <p>Step 3. Check to see if engine oil pressure indicator light illuminates.</p> <ul style="list-style-type: none"> (a) Position master power switch to on (para 2-21a or b). If engine oil pressure indicator light does not illuminate, notify Unit Maintenance. (b) Position master power switch to off (para 2-21f). <p>Step 4. Check to see if OIL PRESS. gage operates.</p> <ul style="list-style-type: none"> (a) Start engine (para 2-21a or b). If OIL PRESS. gage does not operate, notify Unit Maintenance. (b) Shut down engine (para 2-21f).

Table 3-2. Troubleshooting (Cont)

MALFUNCTION	TEST OR INSPECTION	CORRECTIVE ACTION
e. ELECTRICAL SYSTEM (CONT)		
e86.	ELECTRICAL SYSTEM DOES NOT MAINTAIN A CHARGE (CONT).	<p>Step 5. Check to see if alternator belts are tight and in good condition.</p> <p>(a) Raise cab (para 2-22a).</p> <p>(b) Check alternator belts for tension and visible damage. If alternator belts are loose or damaged, notify Unit Maintenance. If alternator belts are tight and free of damage, notify Unit Maintenance.</p> <p>(c) Lower cab (para 2-22b).</p>
e87.	WTEC II TRANSMISSION ECU PUSHBUTTON SHIFT SELECTOR (TEPSS) ILLUMINATION DOES NOT DIM.	<p>Check circuit breaker (CB77) in PDP to see if it is tripped.</p> <p>(a) Remove PDP cover (para 3-13a).</p> <p>(b) Position master power switch to off (para 2-21f).</p> <p>(c) If circuit breaker is tripped, push in to reset.</p> <p>(d) Position master power switch to on (para 2-21a or b).</p> <p>(e) Check circuit breaker to see if it tripped. If circuit breaker is tripped, notify Unit Maintenance.</p> <p>(f) Position master power switch to off (para 2-21f).</p> <p>(g) Install PDP cover (para 3-13b).</p> <p>(h) If WTEC II TEPSS illumination still does not dim, notify Unit Maintenance.</p>
e88.	ENGINE FAN RUNS CONSTANTLY.	<p>Check circuit breaker (CB22) in PDP to see if it is tripped.</p> <p>(a) Remove PDP cover (para 3-13a).</p> <p>(b) Shut down engine (para 2-21f).</p> <p>(c) If circuit breaker is tripped, push in to reset.</p> <p>(d) Start engine (para 2-21a or b).</p> <p>(e) Check circuit breaker to see if it tripped. If circuit breaker is tripped, notify Unit Maintenance.</p> <p>(f) Shut down engine (para 2-21f).</p> <p>(g) Install PDP cover (para 3-13b).</p> <p>(h) If engine fan still runs constantly, notify Unit Maintenance.</p>

Table 3-2. Troubleshooting (Cont)

MALFUNCTION
TEST OR INSPECTION
CORRECTIVE ACTION
<p>e89. ENGINE FAN DOES NOT TURN OFF USING RADIATOR FAN OFF SWITCH.</p>
<p>Check circuit breaker (CB22) in PDP to see if it is tripped.</p>
<ul style="list-style-type: none"> (a) Remove PDP cover (para 3-13a). (b) Shut down engine (para 2-21f). (c) If circuit breaker is tripped, push in to reset. (d) Start engine (para 2-21a or b). (e) Check circuit breaker to see if it tripped. If circuit breaker is tripped, notify Unit Maintenance. (f) Shut down engine (para 2-21f). (g) Install PDP cover (para 3-13b). (h) If engine fan still does not turn off using radiator fan off switch, notify Unit Maintenance.
<p>e90. ETHER START DOES NOT OPERATE.</p>
<p>Check circuit breaker (CB22) in PDP to see if it is tripped.</p>
<ul style="list-style-type: none"> (a) Remove PDP cover (para 3-13a). (b) Position master power switch to off (para 2-21f). (c) If circuit breaker is tripped, push in to reset. (d) Attempt to start engine (para 2-21a or b). (e) Check circuit breaker to see if it tripped. If circuit breaker is tripped, notify Unit Maintenance. (f) Position master power switch to off (para 2-21f). (g) Install PDP cover (para 3-13b). (h) If ether start still does not operate, notify Unit Maintenance.
<p>e91. EXCESSIVE CONDENSATION IN FUEL.</p>
<p>Check circuit breaker (CB79) in PDP to see if it is tripped.</p>
<ul style="list-style-type: none"> (a) Remove PDP cover (para 3-13a). (b) If circuit breaker is tripped, push in to reset. If circuit breaker is tripped or trips again, Notify Unit Maintenance. (c) Install PDP cover (para 3-13b). (d) If excessive condensation is still in fuel, notify Unit Maintenance.

Table 3-2. Troubleshooting (Cont)

MALFUNCTION	TEST OR INSPECTION	CORRECTIVE ACTION
e. ELECTRICAL SYSTEM (CONT)		
e92. RADIO DOES NOT OPERATE.	Check circuit breaker (CB20) in PDP to see if it is tripped.	<ul style="list-style-type: none"> (a) Remove PDP cover (para 3-13a). (b) Position radio to off. (c) Position master power switch to off (para 2-21f). (d) If circuit breaker is tripped, push in to reset. (e) Position master power switch to on (para 2-21a or b). (f) Position radio to on. (g) If circuit breaker is tripped or trips again, notify Unit Maintenance. (h) Position master power switch to off (para 2-21f). (i) Install PDP cover (para 3-13b). (j) If radio still does not operate, notify Unit Maintenance.
e93. START INHIBIT PUSHBUTTON DOES NOT OPERATE.	Check circuit breaker (CB79) in PDP to see if it is tripped.	<ul style="list-style-type: none"> (a) Remove PDP cover (para 3-13a). (b) Position master power switch to off (para 2-21f). (c) If circuit breaker is tripped, push in to reset. (d) Attempt to start engine (2-21a or b). (e) Position master power switch to on (para 2-21a or b). (f) Check circuit breaker to see if it tripped. If circuit breaker is tripped, notify Unit Maintenance.
e94. AIR DRYER DOES NOT OPERATE.	Notify Unit Maintenance.	
e95. BATTERY TESTER DOES NOT OPERATE.	Notify Unit Maintenance.	
e96. M1079 FAN DOES NOT OPERATE.	Check circuit breaker (CB8) in 110/208 VAC POWER DISTRIBUTION PANEL to see if it is tripped.	<ul style="list-style-type: none"> (a) Open 110/208 VAC POWER DISTRIBUTION PANEL cover (para 2-32). (b) If circuit breaker is tripped, position to ON to reset.

Table 3-2. Troubleshooting (Cont)

MALFUNCTION	TEST OR INSPECTION	CORRECTIVE ACTION
e96.	M1079 FAN DOES NOT OPERATE (CONT).	<ul style="list-style-type: none"> (c) Check to see if fan operates. (d) If fan does not operate, or circuit breaker trips again, notify Unit Maintenance.
e97.	ALL M1079 VAN BODY MARKER LIGHTS DO NOT ILLUMINATE.	Notify Unit Maintenance.
e98.	M1079 VAN BODY MARKER LIGHT DOES NOT ILLUMINATE.	Notify Unit Maintenance.
e99.	ALL M1079 FLUORESCENT LIGHTS DO NOT ILLUMINATE.	<p>Check circuit breaker (CB6) in 110/208 VAC POWER DISTRIBUTION PANEL to see if it is tripped.</p> <ul style="list-style-type: none"> (a) Open 110/208 VAC POWER DISTRIBUTION PANEL cover (para 2-32). (b) If circuit breaker is tripped, position to ON to reset. (c) Check to see if fluorescent lights operate. (d) If fluorescent lights do not operate, or circuit breaker trips again, notify Unit Maintenance.
e100.	M1079 FLUORESCENT LIGHT(S) DS80 AND/OR DS81 DO NOT ILLUMINATE.	Notify Unit Maintenance.
e101.	M1079 FLUORESCENT LIGHT(S) DS82 AND/OR DS83 DO NOT ILLUMINATE.	Notify Unit Maintenance.
e102.	M1079 110 VAC OUTLET J233 DOES NOT OPERATE.	<p>Check circuit breaker (CB5) in 110/208 VAC POWER DISTRIBUTION PANEL to see if it is tripped.</p> <ul style="list-style-type: none"> (a) Open 110/208 VAC POWER DISTRIBUTION PANEL cover (para 2-32). (b) If circuit breaker is tripped, position to ON to reset. (c) Check to see if 110 vac outlet J233 operates. (d) If 110 vac outlet J233 does not operate, or circuit breaker trips again, notify Unit Maintenance.
e103.	M1079 110 VAC OUTLET J234 DOES NOT OPERATE.	<p>Check circuit breaker (CB7) in 110/208 VAC POWER DISTRIBUTION PANEL to see if it is tripped.</p> <ul style="list-style-type: none"> (a) Open 110/208 VAC POWER DISTRIBUTION PANEL cover (para 2-32). (b) If circuit breaker is tripped, position to ON to reset.

Table 3-2. Troubleshooting (Cont)

MALFUNCTION	TEST OR INSPECTION	CORRECTIVE ACTION
e. ELECTRICAL SYSTEM (CONT)		
e103.	M1079 110 VAC OUTLET J234 DOES NOT OPERATE (CONT).	<ul style="list-style-type: none"> (c) Check to see if 110 vac outlet J234 operates. (d) If 110 vac outlet J234 does not operate, or circuit breaker trips again, notify Unit Maintenance.
e104.	M1079 110 VAC OUTLET J235 DOES NOT OPERATE.	<p>Check circuit breaker (CB9) in 110/208 VAC POWER DISTRIBUTION PANEL to see if it is tripped.</p> <ul style="list-style-type: none"> (a) Open 110/208 VAC POWER DISTRIBUTION PANEL cover (para 2-32). (b) If circuit breaker is tripped, position to ON to reset. (c) Check to see if 110 vac outlet J235 operates. (d) If 110 vac outlet J235 does not operate, or circuit breaker trips again, notify Unit Maintenance.
e105.	M1079 110 VAC OUTLET J232 DOES NOT OPERATE IN NORMAL MODE.	<p>Check circuit breaker (CB5) in 110/208 VAC POWER DISTRIBUTION PANEL to see if it is tripped.</p> <ul style="list-style-type: none"> (a) Open 110/208 VAC POWER DISTRIBUTION PANEL cover (para 2-32). (b) If circuit breaker is tripped, position to ON to reset. (c) Check to see if 110 vac outlet J232 operates. (d) If 110 vac outlet J232 does not operate, or circuit breaker trips again, notify Unit Maintenance.
e106.	M1079 110 VAC OUTLET J232 AND J233 DO NOT OPERATE IN BLACKOUT OVERRIDE MODE.	<p>Check circuit breaker (CB5) in 110/208 VAC POWER DISTRIBUTION PANEL to see if it is tripped.</p> <ul style="list-style-type: none"> (a) Open 110/208 VAC POWER DISTRIBUTION PANEL cover (para 2-32). (b) If circuit breaker is tripped, position to ON to reset. (c) Check to see if 110 vac outlets J232 and J233 operate. (d) If 110 vac outlets J232 and J233 do not operate, or circuit breaker trips again, notify Unit Maintenance.
e107.	M1079 110 VAC OUTLET J231 DOES NOT OPERATE.	<p>Check circuit breaker (CB7) in 110/208 VAC POWER DISTRIBUTION PANEL to see if it is tripped.</p> <ul style="list-style-type: none"> (a) Open 110/208 VAC POWER DISTRIBUTION PANEL cover (para 2-32).

Table 3-2. Troubleshooting (Cont)

MALFUNCTION	TEST OR INSPECTION	CORRECTIVE ACTION
e107. M1079 110 VAC OUTLET J231 DOES NOT OPERATE (CONT).		
	(b) If circuit breaker is tripped, position to ON to reset.	
	(c) Check to see if 110 vac outlet J231 operates.	
	(d) If 110 vac outlet J231 does not operate, or circuit breaker trips again, notify Unit Maintenance.	
e108. M1079 110 VAC OUTLET J230 DOES NOT OPERATE.		
	Check circuit breaker (CB9) in 110/208 VAC POWER DISTRIBUTION PANEL to see if it is tripped.	
	(a) Open 110/208 VAC POWER DISTRIBUTION PANEL cover (para 2-32).	
	(b) If circuit breaker is tripped, position to ON to reset.	
	(c) Check to see if 110 vac outlet J230 operates.	
	(d) If 110 vac outlet J230 does not operate, or circuit breaker trips again, notify Unit Maintenance.	
e109. M1079 BLACKOUT LIGHT(S) DOES NOT ILLUMINATE.		
	Step 1. Check circuit breakers (CB10 and CB11) on relay box to see if either is tripped.	
	(a) If circuit breakers (CB10 or CB11) are tripped, push in to reset.	
	(b) Check to see if blackout lights operate.	
	(c) Circuit breakers (CB10 or CB11) trips again, notify Unit Maintenance.	
	Step 2. Check to see if emergency lights illuminate (para 2-34).	
	If emergency lights do not illuminate, perform Electrical System Troubleshooting para e114. M1079 24 VDC Binding Post(s) Does Not Operate.	
	If emergency lights do illuminate, notify Unit Maintenance.	
e110. ONE OR MORE M1079 EMERGENCY LIGHTS DO NOT ILLUMINATE.		
	Step 1. Check circuit breakers (CB10 and CB11) on relay box to see if either is tripped.	
	(a) If circuit breakers (CB10 or CB11) are tripped, push in to reset.	
	(b) Check to see if emergency lights operate.	
	(c) Circuit breakers (CB10 or CB11) trip again, notify Unit Maintenance.	
	Step 2. Check to see if blackout lights illuminate (para 2-34).	
	If blackout lights do not illuminate, perform Electrical System troubleshooting para e114. M1079 24 VDC Binding Post(s) Does Not Operate.	
	If blackout lights illuminate, notify Unit Maintenance.	

Table 3-2. Troubleshooting (Cont)

MALFUNCTION
TEST OR INSPECTION
CORRECTIVE ACTION
<p>e. ELECTRICAL SYSTEM (CONT)</p>
<p>e111. M0179 FIELD PHONE 1 AND/OR 2 BINDING POST DOES NOT OPERATE.</p>
<p>Notify Unit Maintenance.</p>
<p>e112. M1079 AIR CONDITIONER DOES NOT OPERATE.</p>
<p>Check circuit breaker (CB2) in 110/208 VAC POWER DISTRIBUTION PANEL to see if it is tripped.</p>
<p>(a) Open 110/208 VAC POWER DISTRIBUTION PANEL cover (para 2-32).</p>

Table 3-2. Troubleshooting (Cont)

MALFUNCTION	TEST OR INSPECTION	CORRECTIVE ACTION
e. ELECTRICAL SYSTEM (CONT)		
e112.	M1079 AIR CONDITIONER DOES NOT OPERATE (CONT).	<ul style="list-style-type: none"> (b) If circuit breaker is tripped, position to ON to reset. (c) Check to see if air conditioner operates. (d) If air conditioner does not operate, or circuit breaker trips again, notify Unit Maintenance.
e113.	M1079 HEATER DOES NOT OPERATE.	<p>Check circuit breaker (CB8) in 110/208 VAC POWER DISTRIBUTION PANEL to see if it is tripped.</p> <ul style="list-style-type: none"> (a) Open 110/208 VAC POWER DISTRIBUTION PANEL cover (para 2-32). (b) If circuit breaker is tripped, position to ON to reset. (c) Check to see if heater operates. (d) If heater does not operate, or circuit breaker trips again, notify Unit Maintenance.
e114.	M1079 24 VDC BINDING POST(S) DOES NOT OPERATE.	<p>Check circuit breaker (CB10) on relay box to see if it is tripped.</p> <ul style="list-style-type: none"> (a) Check fuse in 12/24 volt cable. (b) If circuit breaker is tripped, push in to reset. (c) Check to see if 24 vdc binding post(s) operate. (d) If 24 vdc binding post(s) does not operate, or circuit breaker trips again, notify Unit Maintenance.
e115.	M1079 VAN DOOR OPEN LIGHT DOES NOT ILLUMINATE AND AUDIBLE ALARM DOES NOT OPERATE.	<p>Notify Unit Maintenance.</p>
e116.	M1079 110 VAC POWER DOES NOT OPERATE.	<p>Notify Unit Maintenance.</p>
e117.	M1079 FLUORESCENT LIGHTS DO NOT ILLUMINATE IN BLACKOUT OVERRIDE MODE.	<p>Notify Unit Maintenance.</p>
f. TRANSMISSION SYSTEM		
f1.	WTEC II TRANSMISSION ECU PUSHBUTTON SHIFT SELECTOR (TEPSS) EMITS EIGHT SECONDS OF BEEPS AND/OR TRANSMISSION DOES NOT SHIFT GEARS.	<p>Notify Unit Maintenance.</p>

Table 3-2. Troubleshooting (Cont)

MALFUNCTION	TEST OR INSPECTION	CORRECTIVE ACTION
f1a.	WTEC II TRANSMISSION ECU PUSHBUTTON SHIFT SELECTOR (TEPSS) DOES NOT ILLUMINATE.	<p style="text-align: center;">NOTE</p> <p>Perform Electrical System Troubleshooting (e1. Engine Does Not Crank), prior to beginning this task.</p> <p>Check circuit breaker (CB35 and CB79) in PDP to see if they are tripped.</p> <p>(a) Remove PDP cover (para 3-13a).</p> <p>(b) Position master power switch to off (para 2-21f).</p> <p>(c) If circuit breaker(s) is tripped, push in to reset.</p> <p>(d) Position master power switch to on (para 2-21a or b).</p> <p>(e) Check circuit breakers in PDP to see if they tripped again. If circuit breakers tripped again, notify Unit Maintenance.</p> <p>(f) Position master power switch to off (para 2-21f).</p> <p>(g) Install PDP cover (para 3-13b).</p> <p>(h) If WTEC II TEPSS still does not illuminate, notify Unit Maintenance.</p>
f2.	TRANSMISSION UNUSUALLY NOISY WHEN OPERATING.	<p>Step 1. Check transmission oil level (para 2-15, item 35).</p> <p>(a) If transmission oil level is low, add transmission oil (Appendix F).</p> <p>(b) If transmission oil level is high, notify Unit Maintenance.</p> <p>Step 2. Check transmission oil for contamination.</p> <p>(a) If transmission oil is contaminated, notify Unit Maintenance.</p> <p>(b) If transmission oil level is still unusually noisy when operating, notify Unit Maintenance.</p>
f3.	WTEC III TRANSMISSION PUSHBUTTON SHIFT SELECTOR (TPSS) DISPLAYS "--" AND/OR TRANSMISSION DOES NOT SHIFT GEARS.	<p>Notify Unit Maintenance.</p>
f4.	TRANSMISSION PUSHBUTTON SHIFT SELECTOR DOES NOT OPERATE.	<p style="text-align: center;">NOTE</p> <p>Perform Electrical System Troubleshooting (e1. Engine Does Not Crank), prior to beginning this task.</p> <p>Check circuit breaker (CB43 and CB79) in PDP to see if they are tripped.</p> <p>(a) Remove PDP cover (para 3-13a).</p>

Table 3-2. Troubleshooting (Cont)

MALFUNCTION	TEST OR INSPECTION	CORRECTIVE ACTION
f. TRANSMISSION SYSTEM (CONT)		
f4. TRANSMISSION PUSHBUTTON SHIFT SELECTOR DOES NOT OPERATE (CONT).		<ul style="list-style-type: none"> (b) Position master power switch to off (para 2-21f). (c) If circuit breaker(s) is tripped, push in to reset. (d) Position master power switch to on (para 2-21f). (e) Check circuit breaker(s) in PDP to see if they tripped again. If circuit breaker(s) tripped again, notify Unit Maintenance. (f) Position master power switch to off (para 2-21f). (g) Install PDP cover (para 3-13b). (h) If WTEC III TPSS still does not illuminate, notify Unit Maintenance.
g. PROPELLER SHAFT		
g1. PROPELLER SHAFTS OR UNIVERSAL JOINTS UNUSUALLY NOISY WHEN OPERATING.		Notify Unit Maintenance.
h. POWER TAKE-OFF (PTO)		
h1. POWER TAKE-OFF (PTO) DOES NOT ENGAGE.		Notify Unit Maintenance.
i. BRAKE SYSTEM		
i1. EXCESSIVE BRAKING DISTANCE.		<p>Check to see if air tanks are pressurized.</p> <ul style="list-style-type: none"> (a) Start engine (para 2-21a or b). (b) Allow engine to idle until 120 psi (827 kPa) is registered on FRONT BRAKE AIR and REAR BRAKE AIR pressure gages. (c) Shut down engine (para 2-21f). (d) If either FRONT BRAKE AIR or REAR BRAKE AIR pressure gages do not register 120 psi (827 kPa), notify Unit Maintenance. (e) If braking distance is still excessive, notify Unit Maintenance.
i2. REAR BRAKES DO NOT APPLY.		<p>Check to see if air tanks are pressurized.</p> <ul style="list-style-type: none"> (a) Start engine (para 2-21a or b). (b) Allow engine to idle until 120 psi (827 kPa) is registered on FRONT BRAKE AIR and REAR BRAKE AIR pressure gages. (c) Shut down engine (para 2-21f).

Table 3-2. Troubleshooting (Cont)

MALFUNCTION	TEST OR INSPECTION	CORRECTIVE ACTION
i2. REAR BRAKES DO NOT APPLY (CONT).	<ul style="list-style-type: none"> (d) If either FRONT BRAKE AIR or REAR BRAKE AIR pressure gages do not register 120 psi (827 kPa), notify Unit Maintenance. (e) If rear brakes still do not apply, notify Unit Maintenance. 	
i3. PARKING BRAKE(S) WILL NOT RELEASE.	<p>Step 1. Check to see if air tanks are pressurized.</p> <ul style="list-style-type: none"> (a) Start engine (para 2-21a or b). (b) Allow engine to idle until 120 psi (827 kPa) is registered on FRONT BRAKE AIR and REAR BRAKE AIR pressure gages. (c) Shut down engine (para 2-21f). <p>If either FRONT BRAKE AIR or REAR BRAKE AIR pressure gages do not register 120 psi (827 kPa), perform Air System troubleshooting (Air System Loses Pressure During Operation/Slow Air Pressure Build Up)..</p>	
	NOTE	
	<p>If FRONT BRAKE AIR and REAR BRAKE AIR pressure gages register 120 psi, then perform step 2 of this malfunction.</p>	
	<p>Step 2. Are front and rear gladhands secure and free from damage?</p> <ul style="list-style-type: none"> (a) Check front and rear gladhands are properly secure and free from damage. (b) Check front gladhands do not have clogged vent ports. <p>If gladhands are damaged or clogged, notify Unit Maintenance.</p> <p>If gladhands are undamaged and unclogged, perform step 3 of this malfunction.</p>	
	<p>Step 3. Does parking brake release?</p> <p>If parking brake still does not release, notify Unit Maintenance.</p>	
i4. FRONT BRAKES OVERHEAT AND/OR DO NOT RELEASE.	<p>Step 1. Check tires for proper inflation and damage (para 2-15, item 38).</p> <ul style="list-style-type: none"> (a) If tires are improperly inflated, start engine (2-21a or b) and select correct CTIS mode. (b) Shut down engine (para 2-21f). (c) Check for proper inflation. (d) If tires are damaged, notify Unit Maintenance. <p>Step 2. Inspect front gladhands.</p> <ul style="list-style-type: none"> (a) Check front gladhands for damage and air leaks. <p>If damage is present or air leaks are heard, notify Unit Maintenance.</p> <ul style="list-style-type: none"> (b) Remove dummy couplings and check for obstructions. 	

Table 3-2. Troubleshooting (Cont)

MALFUNCTION	TEST OR INSPECTION	CORRECTIVE ACTION
i4.	FRONT BRAKES OVERHEAT AND/OR DO NOT RELEASE (Cont).	<p>If gladhands are obstructed, clean gladhands.</p> <ul style="list-style-type: none"> (c) Inspect and lubricate coupler seals (Appendix F) (d) Ensure that dummy couplings are properly installed. (e) If front brakes still overheat, notify Unit Maintenance.

Table 3-2. Troubleshooting (Cont)

MALFUNCTION	TEST OR INSPECTION	CORRECTIVE ACTION
i. BRAKE SYSTEM (CONT)		
i5. VEHICLE BRAKES UNEVENLY, BRAKES PULL TO ONE SIDE, OR GRAB.		<p>Check to see if air tanks are pressurized.</p> <ul style="list-style-type: none"> (a) Start engine (para 2-21a or b). (b) Allow engine to idle until 120 psi (827 kPa) is registered on FRONT BRAKE AIR and REAR BRAKE AIR pressure gages. (c) Shut down engine (para 2-21f). (d) If either FRONT BRAKE AIR or REAR BRAKE AIR pressure gages do not register 120 psi (827 kPa), notify Unit Maintenance. (e) If vehicle still brakes unevenly, brakes pull to one side, or grab, notify Unit Maintenance.
i6. FRONT BRAKES DO NOT APPLY.		<p>Check to see if air tanks are pressurized.</p> <ul style="list-style-type: none"> (a) Start engine (para 2-21a or b). (b) Allow engine to idle until 120 psi (827 kPa) is registered on FRONT BRAKE AIR and REAR BRAKE AIR pressure gages. (c) Shut down engine (para 2-21f). (d) If either FRONT BRAKE AIR or REAR BRAKE AIR pressure gages do not register 120 psi (827 kPa), notify Unit Maintenance. (e) If front brakes still do not apply, notify Unit Maintenance.
i7. REAR BRAKES OVERHEAT.		<p>Check tires for proper inflation and damage (para 2-15, item 38).</p> <ul style="list-style-type: none"> (a) If tires are improperly inflated, start engine (para 2-21a or b) and select correct CTIS mode. (b) Shut down engine (para 2-21f). (c) Check for proper inflation. (d) If tires are damaged, notify Unit Maintenance. (e) If rear brakes still overheat, notify Unit Maintenance.
i8. PARKING BRAKES DO NOT APPLY.		<p>Check front and rear air pressure gages for 65-120 psi (448-827 Kpa) (para 2-21a or b).</p> <p>If air pressure is below 65 psi (448 Kpa), notify Unit Maintenance. If parking brakes still do not apply, notify Unit Maintenance.</p>
i9. BRAKE SYSTEM LOSES AIR WHEN SERVICE BRAKES ARE APPLIED.		<p>Notify Unit Maintenance.</p>

Table 3-2. Troubleshooting (Cont)

MALFUNCTION	TEST OR INSPECTION	CORRECTIVE ACTION
j. AIR SYSTEM		
j1.	AIR SYSTEM LOSES PRESSURE DURING OPERATION/SLOW, NO, OR INCORRECT AIR PRESSURE BUILDUP.	Notify Unit Maintenance.
j2.	LARGE QUANTITY OF MOISTURE EXPELLED FROM AIR RESERVOIRS.	Notify Unit Maintenance.
j3.	AIR DRYER PURGES CONTINUALLY.	Notify Unit Maintenance.
j4.	NO AIR PRESSURE PRESENT AT REAR GLADHAND(S).	<p>Step 1. Check to see if vehicle brakes operate.</p> <ul style="list-style-type: none"> (a) Check vehicle parking brakes (para 2-21). If parking brakes do not apply, perform Brake System Troubleshooting (i8. Parking Brakes Do Not Apply). (b) Check vehicle service brakes (para 2-21). If service brakes do not apply, perform Brake System Troubleshooting (i1. Excessive Braking Distance). <p>Step 2. Inspect air hoses for kinks, damage, and leaks.</p> <ul style="list-style-type: none"> (a) Inspect air hoses from rear gladhands to air brake protecting valve. (b) Inspect air hoses from air brake protecting valve to TRAILER AIR SUPPLY valve. (c) Inspect air hose from air brake protecting valve to inversion valve. (d) Inspect air hose from inversion valve to front axle quick release valve tee fitting. (e) Inspect air hose from air brake protecting valve to load sensing valve. (f) Inspect air hose from load sensing valve to service gladhand two-way check valve. If any air hose is kinked, damaged, or leaking; notify Unit Maintenance. <p>Step 3. If air pressure is still not present at rear gladhand(s), notify Unit Maintenance.</p>
j5.	AIR SYSTEM PRESSURE BUILDS UP MORE THAN 120 PSI (827 KPA) (COMPRESSOR FAILS TO UNLOAD).	Notify Unit Maintenance.
j6.	NOISY AIR COMPRESSOR OPERATION.	Notify Unit Maintenance.

Table 3-2. Troubleshooting (Cont)

MALFUNCTION	TEST OR INSPECTION	CORRECTIVE ACTION
k. WHEEL		
k1. TIRES WEAR UNEVENLY OR EXCESSIVELY.	Check tire pressures with tire gage for each CTIS setting.	(a) Notify Unit Maintenance if tire pressures do not match those given below:
<u>ALL MODELS</u>		
	HWY Mode	55 psi (379 kPa)
	X-C Mode	33 psi (228 kPa)
	SAND Mode	20 psi (138 kPa)
	EMER Mode	14 psi (97 Kpa)
	(b) If tires still wear unevenly or excessively, notify Unit Maintenance.	
k2. WHEEL WOBBLES OR SHIMMIES.	Step 1. Check wheel studs and lugnuts for obvious looseness.	
WARNING		
Notify Unit Maintenance that lugnuts need to be tightened to 415-475 lb-ft (563-644 N-m) as soon as possible. Wheel may come loose if lugnuts are not tightened to proper torque. Failure to comply may result in serious injury or death to personnel.		
If loose, tighten.		
Step 2. Check for bent or broken studs and missing or loose lugnuts.		
	(a) Notify Unit Maintenance if two or more lugnuts or studs on the same wheel are missing, broken, or bent.	
	(b) If wheel still wobbles or shimmies, notify Unit Maintenance.	

Table 3-2. Troubleshooting (Cont)

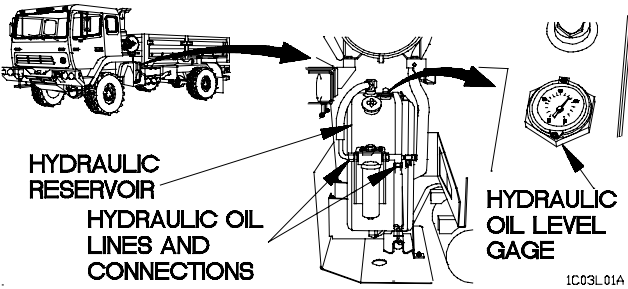
MALFUNCTION	TEST OR INSPECTION	CORRECTIVE ACTION
I. HYDRAULIC SYSTEM		
11. LOSS OF HYDRAULIC PRESSURE (SINGLE STAGE PUMP).	 <p>The diagram shows a truck on the left with an arrow pointing to a detailed view of the hydraulic system. Labels include 'HYDRAULIC RESERVOIR', 'HYDRAULIC OIL LINES AND CONNECTIONS', and 'HYDRAULIC OIL LEVEL GAGE'. A small inset shows a close-up of the gage with a needle pointing to a mark. The code '1C03L01A' is at the bottom right of the diagram.</p>	
NOTE		
<p>Hydraulic oil level gage should read two marks past the 3/4 mark during a cold check. This is a normal reading. Do not overfill reservoir.</p>		
<p>Check hydraulic oil level gage to determine hydraulic oil level.</p>		
<ul style="list-style-type: none"> (a) If oil level is low, add hydraulic oil (Appendix F). (b) If loss of hydraulic pressure continues, notify Unit Maintenance. 		
m. CENTRAL TIRE INFLATION SYSTEM (CTIS)		
m1. TWO STEADY MODE LIGHTS ILLUMINATE ON CENTRAL TIRE INFLATION SYSTEM (CTIS) ECU.		<p>Notify Unit Maintenance.</p>
m2. FOUR CENTRAL TIRE INFLATION SYSTEM (CTIS) ECU INDICATOR LIGHTS FLASHING.		<p>Notify Unit Maintenance.</p>
m3. FIVE CENTRAL TIRE INFLATION SYSTEM (CTIS) ECU INDICATOR LIGHTS FLASHING.		<p>Notify Unit Maintenance.</p>
m4. CENTRAL TIRE INFLATION SYSTEM (CTIS) REPEATEDLY RESUMES CYCLING 30 SECONDS AFTER INDICATOR LIGHTS STOP FLASHING.		<p>Notify Unit Maintenance.</p>
m5. CENTRAL TIRE INFLATION SYSTEM (CTIS) ECU INDICATES NO FAULT CODE BUT SYSTEM FAILS TO INFLATE OR DEFLATE.		<p>Notify Unit Maintenance.</p>

Table 3-2. Troubleshooting (Cont)

**MALFUNCTION
TEST OR INSPECTION
CORRECTIVE ACTION**

m. CENTRAL TIRE INFLATION SYSTEM (CTIS) (CONT)

m6. NO OVERSPEED WARNING LIGHT AND/OR OVERSPEED PRESSURE CHANGE.

Notify Unit Maintenance.

n. AXLE

n1. AXLE DIFFERENTIAL(S) NOISY.

Notify Unit Maintenance.

p. STEERING SYSTEM

p1. HARD TO STEER.

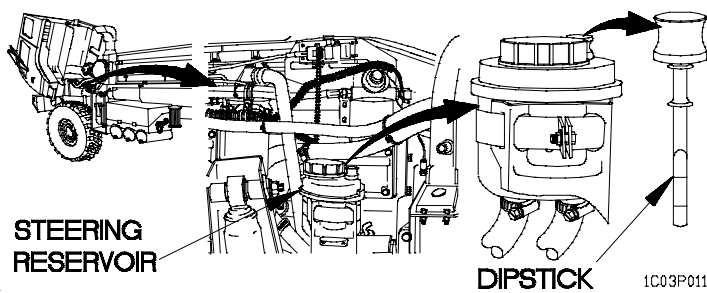
Step 1. Check tire pressures with tire gage for each CTIS setting.

Notify Unit Maintenance if tire pressures do not match those given below:

ALL MODELS

HWY Mode	55 psi (379 kPa)
X-C Mode	33 psi (228 kPa)
SAND Mode	20 psi (138 kPa)
EMER Mode	14 psi (97 kPa)

Step 2. Raise cab (para 2-22a).



CAUTION

Do not overfill power steering reservoir. Damage to steering system may result if too much oil is added.

Table 3-2. Troubleshooting (Cont)

MALFUNCTION	TEST OR INSPECTION	CORRECTIVE ACTION								
p1. HARD TO STEER (CONT).		<p>Step 3. Check that steering reservoir is filled to proper level. Oil should be level with full mark on dipstick.</p> <ul style="list-style-type: none"> (a) Add oil as required (Appendix F). (b) If oil level is over full mark, notify Unit Maintenance. (c) If vehicle is still hard to steer, notify Unit Maintenance. <p>Step 4. Lower cab (para 2-22b).</p>								
p2. WANDERS, PULLS TO ONE SIDE, OR SHIMMIES.	<div style="border: 1px solid black; padding: 5px; text-align: center; width: fit-content; margin: 0 auto;">WARNING</div>	<p>Notify Unit Maintenance that lugnuts need to be tightened to 415-475 lb-ft (563-644 N-m) as soon as possible. Wheel may come loose if lugnuts are not tightened to proper torque. Failure to comply may result in serious injury or death to personnel.</p> <p>If loose, tighten.</p> <p>Step 2. Check for bent or broken studs and missing or loose lugnuts.</p> <p>Step 3. Check tire pressures with tire gage for each CTIS setting.</p> <ul style="list-style-type: none"> (a) Notify Unit Maintenance if tire pressures do not match those given below: 								
	<p><u>ALL MODELS</u></p>	<table style="width: 100%; border-collapse: collapse;"> <tbody> <tr> <td style="width: 50%;">HWY Mode</td> <td>55 psi (379 kPa)</td> </tr> <tr> <td>X-C Mode</td> <td>33 psi (228 kPa)</td> </tr> <tr> <td>SAND Mode</td> <td>20 psi (138 kPa)</td> </tr> <tr> <td>EMER Mode</td> <td>14 psi (97 kPa)</td> </tr> </tbody> </table>	HWY Mode	55 psi (379 kPa)	X-C Mode	33 psi (228 kPa)	SAND Mode	20 psi (138 kPa)	EMER Mode	14 psi (97 kPa)
HWY Mode	55 psi (379 kPa)									
X-C Mode	33 psi (228 kPa)									
SAND Mode	20 psi (138 kPa)									
EMER Mode	14 psi (97 kPa)									

Table 3-2. Troubleshooting (Cont)

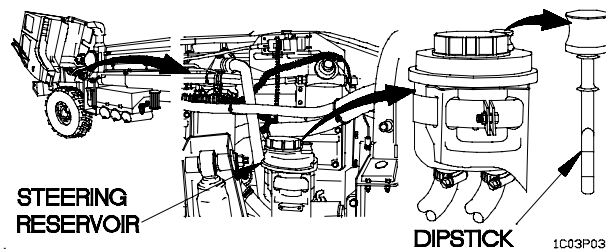
**MALFUNCTION
TEST OR INSPECTION
CORRECTIVE ACTION**

p. STEERING SYSTEM (CONT)

p2. WANDERS, PULLS TO ONE SIDE, OR SHIMMIES (CONT).

- (b) If vehicle still wanders, pulls to one side, or shimmies, perform Suspension System Troubleshooting (q1. Wanders, Pulls to One Side, or Shimmies).

p3. EXCESSIVE PLAY WHEN TURNING STEERING WHEEL.



CAUTION

Check that steering reservoir is filled to proper level. Oil should be level with full mark on dipstick.

- (a) Add oil as required (Appendix F).
- (b) If oil level is over full mark, notify Unit Maintenance.
- (c) If vehicle still has excessive play when turning steering wheel, notify Unit Maintenance.
- (d) Lower cab (para 2-22b).

p4. NO RESPONSE WHEN TURNING STEERING WHEEL.

Notify Unit Maintenance.

q. SUSPENSION SYSTEM

q1. WANDERS, PULLS TO ONE SIDE, OR SHIMMIES.

- Step 1. Perform Steering System Troubleshooting (p2. Wanders, Pulls to One Side, or Shimmies).
- Step 2. Perform Brake System Troubleshooting (i5. Vehicle Brakes Unevenly, Brakes Pull to One Side or Grab).
- Step 3. If vehicle continues to wander, pull to one side, or shimmy, notify Unit Maintenance.

q2. LEANS TO ONE SIDE, OR REAR OF VEHICLE SAGS.

Notify Unit Maintenance.

Table 3-2. Troubleshooting (Cont)

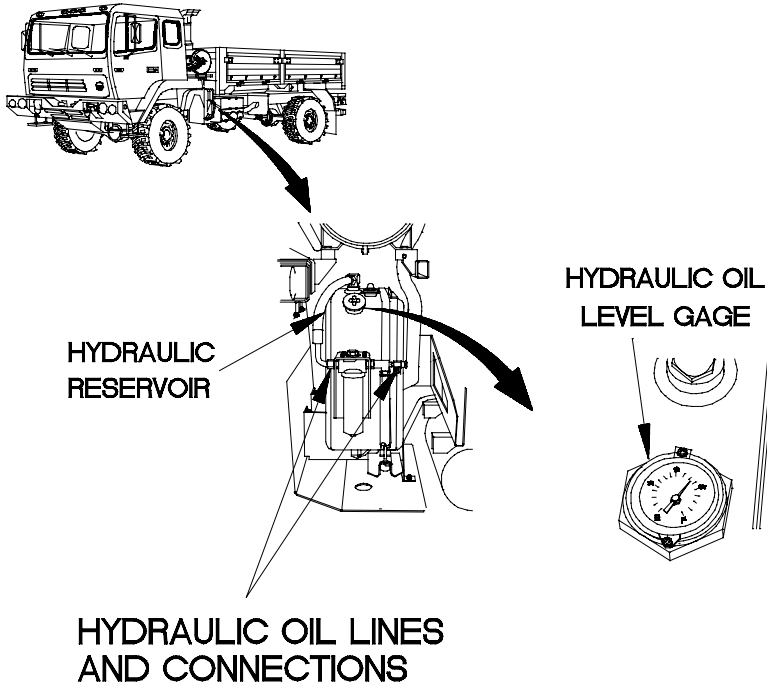
MALFUNCTION	TEST OR INSPECTION	CORRECTIVE ACTION
r. 11K SELF-RECOVERY WINCH (SRW) SYSTEM		
r1.	11K SELF-RECOVERY WINCH (SRW) DOES NOT OPERATE.	<div data-bbox="399 596 1161 1276" style="text-align: center;">  <p>HYDRAULIC RESERVOIR</p> <p>HYDRAULIC OIL LINES AND CONNECTIONS</p> <p>HYDRAULIC OIL LEVEL GAGE</p> </div> <p data-bbox="1118 1350 1187 1367" style="text-align: right;">1C03R011</p> <p data-bbox="760 1440 821 1461" style="text-align: center;">NOTE</p> <p data-bbox="399 1482 1153 1535">Hydraulic oil level gage should read two marks past the 3/4 mark during a cold check. This is a normal reading. Do not overfill reservoir.</p> <p data-bbox="321 1556 992 1581">Step 1. Check hydraulic oil level gage to determine hydraulic oil level.</p> <p data-bbox="337 1602 797 1627">If oil level is low, add hydraulic oil (Appendix F).</p> <p data-bbox="321 1648 898 1673">Step 2. Check hydraulic lines and fittings for Class III leaks.</p> <p data-bbox="337 1694 1167 1719">If Class III leaks are found or 11K SRW still does not operate, notify Unit Maintenance.</p>

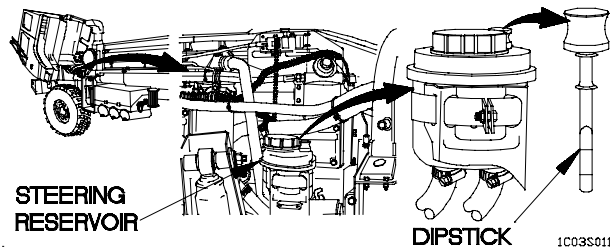
Table 3-2. Troubleshooting (Cont)

**MALFUNCTION
TEST OR INSPECTION
CORRECTIVE ACTION**

s. STEERING HYDRAULIC SYSTEM

s1. STEERING HARD OR DOES NOT OPERATE.

Step 1. Raise cab (para 2-22a).



CAUTION

Do not overfill power steering reservoir. Failure to comply may result in damage to equipment.

Step 2. Check that steering reservoir is filled to proper level. Oil should be level with full mark on dipstick.

- (a) Add oil as required.
- (b) If oil is over full mark, notify Unit Maintenance.

Step 3. Check hydraulic lines and fittings for Class III leaks.

- (a) If Class III leaks are found or steering is still hard or does not operate, notify Unit Maintenance.
- (b) Lower cab (para 2-22b).

t. AIR TRANSPORT SYSTEM

t1. CAB TILT, SPARE TIRE RETAINER, AND SUSPENSION COMPRESSION DO NOT OPERATE.

Check hydraulic hoses, air lines, and fittings for Class III leaks.

If Class III leaks are found or cab tilt, spare tire retainer, and suspension compression still do not operate, notify Unit Maintenance.

t2. SUSPENSION DOES NOT COMPRESS OR RETURN TO NORMAL PROPERLY.

Step 1. Check to see if cab raises (para 2-22a).

If cab does not raise, perform Air System Troubleshooting (t1. Cab Tilt, Spare Tire Retainer and Suspension Compression Do Not Work).

Table 3-2. Troubleshooting (Cont)

MALFUNCTION	TEST OR INSPECTION	CORRECTIVE ACTION
t2. SUSPENSION DOES NOT COMPRESS OR RETURN TO NORMAL PROPERLY (CONT).	Step 2. Check hydraulic hoses, air lines, and fittings for Class III leaks.	If Class III leaks are found or suspension still will not compress or return to normal properly, notify Unit Maintenance.
t3. CAB LEVELING AIR SPRINGS DO NOT OPERATE PROPERLY.	Step 1. Check to see if CTIS operates properly (para 2-23).	If CTIS does not operate properly, perform applicable CTIS System Troubleshooting (m. Central Tire Inflation System (CTIS).
	Step 2. Check leveling air springs (air bags), air lines, and fittings for air leaks.	
	(a) Start engine (para 2-21a or b).	
	(b) Raise cab (para 2-22a).	
	(c) Check leveling air springs (air bags), air lines, and fittings for air leaks. If air leaks are found, notify Unit Maintenance.	
	(d) Lower cab (para 2-22b).	
	(e) Shut down engine (para 2-21f).	
	u. SPECIAL PURPOSE KIT	
u1. NO POWER TO DIGITIZATION RACK.	Notify Unit Maintenance.	
u2. NO POWER TO MOBILE TRACKING SYSTEM (MTS) SENSE.		
<div style="border: 1px solid black; padding: 5px; width: fit-content; margin: 0 auto;">WARNING</div>		
<p>Remove rings, bracelets, wristwatches, neck chains, and any other jewelry before working around vehicle. Jewelry may catch on equipment or may short across an electrical circuit. Failure to comply may result in serious injury or death to personnel.</p>		
Check to see if circuit breaker (CB1) is tripped.		
	(a) Remove wing screw from power distribution shelf.	
	(b) Loosen wing screw on electrical distribution block cover.	
	(c) Remove electrical distribution block cover from electrical distribution shelf.	

Table 3-2. Troubleshooting (Cont)

MALFUNCTION	TEST OR INSPECTION	CORRECTIVE ACTION
u. SPECIAL PURPOSE KIT (CONT)		
u2.	NO POWER TO MOBILE TRACKING SYSTEM (MTS) SENSE (CONT).	<div data-bbox="428 569 1143 877" data-label="Image"> <p>The diagram shows a perspective view of an electrical distribution block cover being attached to a power distribution shelf. Two wing screws are shown being inserted into the cover to secure it to the shelf. Labels with arrows point to the 'WING SCREW' on both sides, the 'ELECTRICAL DISTRIBUTION BLOCK COVER', and the 'POWER DISTRIBUTION SHELF'.</p> </div> <p data-bbox="1068 898 1136 919" style="text-align: right;">1c03u011</p> <p data-bbox="337 940 964 1014"> (d) Check circuit breaker (CB1) to see if it is tripped. If circuit breaker (CB1) is tripped, push reset button in to reset. </p> <div data-bbox="461 1045 1062 1402" data-label="Image"> <p>The diagram shows a close-up of a circuit breaker (CB1) with a reset button. Arrows point to the 'RESET BUTTON' and the 'CIRCUIT BREAKER CB1'.</p> <p data-bbox="1068 1398 1136 1419" style="text-align: right;">1C03U021</p> <p data-bbox="337 1440 1208 1734"> (e) Position master power switch to ON (para 2-21a or b). If circuit breaker (CB1) trips again, notify Unit Maintenance. If circuit breaker is not tripped, but there is still no power to MTS, notify Unit Maintenance. (f) Position master power switch to OFF (para 2-21f). (g) Position electrical distribution block cover on power distribution shelf. (h) Tighten wing screw on electrical distribution block cover. (i) Install wing screw in power distribution shelf. </p> </div>

Table 3-2. Troubleshooting (Cont)

MALFUNCTION
TEST OR INSPECTION
CORRECTIVE ACTION
u3. NO POWER TO ENHANCED POSITION LOCATION REPORTING SYSTEM (EPLRS).
<div style="border: 1px solid black; padding: 5px; width: fit-content; margin: 0 auto;">WARNING</div>
<p>Remove rings, bracelets, wristwatches, neck chains, and any other jewelry before working around vehicle. Jewelry may catch on equipment or may short across an electrical circuit. Failure to comply may result in serious injury or death to personnel.</p>
<p>Step 1. Check to see if circuit breaker (CB5) is tripped.</p>
<ul style="list-style-type: none"> (a) Remove wing screw from power distribution shelf. (b) Loosen wing screw on electrical distribution block cover. (c) Remove electrical distribution block cover from power distribution shelf.
<p>1c03u011</p>
<p>(d) Check to see if circuit breaker (CB5) is tripped.</p>
<p>1C03U031</p>
<p>If circuit breaker (CB5) is tripped, push reset button in to reset.</p>
<p>If circuit breaker (CB5) trips again, notify Unit Maintenance.</p>

Table 3-2. Troubleshooting (Cont)

**MALFUNCTION
TEST OR INSPECTION
CORRECTIVE ACTION**

u. SPECIAL PURPOSE KIT (CONT)

u3. NO POWER TO ENHANCED POSITION LOCATION REPORTING SYSTEM (EPLRS) (CONT).

Step 2. Check to see if Enhanced Position Location Reporting System (EPLRS) has power.

If EPLRS does not have power, notify Unit Maintenance.

- (a) Position electrical distribution block cover on power distribution shelf.
- (b) Tighten wing screw on electrical distribution block cover.
- (c) Install wing screw on power distribution shelf.

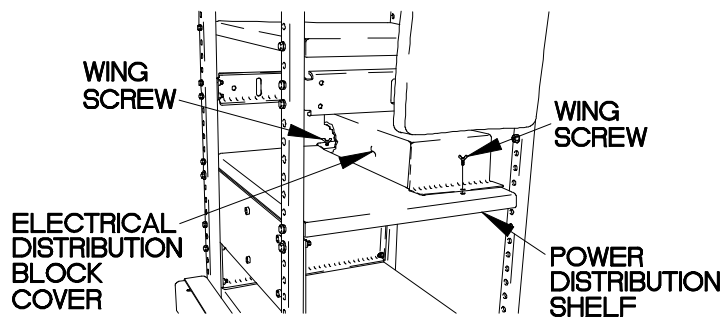
u4. NO POWER TO PRECISION LIGHTWEIGHT GLOBAL POSITIONING SYSTEM RECEIVER (PLGR)

WARNING

Remove rings, bracelets, wristwatches, neck chains, and any other jewelry before working around vehicle. Jewelry may catch on equipment or may short across an electrical circuit. Failure to comply may result in serious injury or death to personnel.

Step (1). Check to see if circuit breaker (CB7) is tripped.

- (a) Remove wing screw from power distribution shelf.
- (b) Loosen wing screw on electrical distribution block cover.
- (c) Remove electrical distribution block cover from power distribution shelf.



1c03u011

- (d) Check to see if circuit breaker (CB7) is tripped.

Table 3-2. Troubleshooting (Cont)

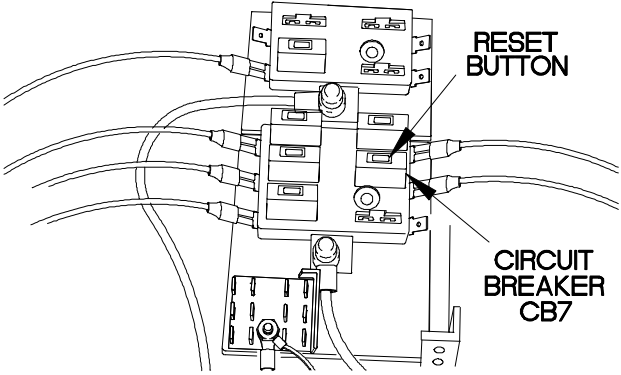
MALFUNCTION	TEST OR INSPECTION	CORRECTIVE ACTION
u4.	NO POWER TO PRECISION LIGHTWEIGHT GLOBAL POSITIONING SYSTEM RECEIVER (PLGR) (CONT)	 <p data-bbox="1065 856 1138 873">1C03U041</p> <p data-bbox="396 898 964 926">If circuit breaker (CB7) is tripped, push reset button in to reset.</p> <p data-bbox="396 942 932 970">If circuit breaker (CB7) trips again, notify Unit Maintenance.</p> <p data-bbox="318 989 1260 1016">Step (2). Check to see if Precision Lightweight Global Positioning System Receiver (PLGR) has power.</p> <p data-bbox="396 1033 894 1060">If PLGR does not have power, notify Unit Maintenance.</p> <ul style="list-style-type: none"> <li data-bbox="337 1079 1019 1106">(a) Position electrical distribution block cover on power distribution shelf. <li data-bbox="337 1123 906 1150">(b) Tighten wing screw on electrical distribution block cover. <li data-bbox="337 1167 808 1194">(c) Install wing screw on power distribution shelf.
u5.	NO POWER TO DRIVER VISUAL ENHANCEMENT (DVE)	<div style="border: 1px solid black; padding: 5px; text-align: center; margin-bottom: 10px;">WARNING</div> <p data-bbox="337 1331 1243 1457">Remove rings, bracelets, wristwatches, neck chains, and any other jewelry before working around vehicle. Jewelry may catch on equipment or may short across an electrical circuit. Failure to comply may result in serious injury or death to personnel.</p> <p data-bbox="318 1476 837 1503">Step (1). Check to see if circuit breaker (CB6) is tripped.</p> <ul style="list-style-type: none"> <li data-bbox="337 1522 849 1549">(a) Remove wing screw from power distribution shelf. <li data-bbox="337 1566 906 1593">(b) Loosen wing screw on electrical distribution block cover. <li data-bbox="337 1610 1040 1638">(c) Remove electrical distribution block cover from power distribution shelf.

Table 3-2. Troubleshooting (Cont)

MALFUNCTION	TEST OR INSPECTION	CORRECTIVE ACTION
u. SPECIAL PURPOSE KIT (CONT)		
u5.	NO POWER TO DRIVER VISUAL ENHANCEMENT (DVE) (CONT).	<div data-bbox="427 558 1143 869" data-label="Image"> </div> <p data-bbox="1068 890 1143 911" style="text-align: right;">1c03u011</p> <p data-bbox="337 932 824 961">(d) Check to see if circuit breaker (CB6) is tripped.</p> <div data-bbox="467 987 1101 1360" data-label="Image"> </div> <p data-bbox="1068 1344 1143 1365" style="text-align: right;">1C03U051</p> <p data-bbox="391 1386 966 1415">If circuit breaker (CB6) is tripped, push reset button in to reset.</p> <p data-bbox="391 1432 935 1461">If circuit breaker (CB6) trips again, notify Unit Maintenance.</p> <p data-bbox="321 1478 971 1507">Step (2). Check to see if Driver Visual Enhancement (DVE) has power.</p> <p data-bbox="391 1524 870 1554">If DVE dos not have power, notify Unit Maintenance.</p> <p data-bbox="337 1570 1019 1688"> <ul style="list-style-type: none"> (a) Position electrical distribution block cover on power distribution shelf. (b) Tighten wing screw on electrical distribution block cover. (c) Install wing screw on power distribution shelf. </p>

Table 3-2. Troubleshooting (Cont)

MALFUNCTION
TEST OR INSPECTION
CORRECTIVE ACTION
<p>u6. NO POWER TO SINGGAR/FORCE XXI BATTLE COMMAND BRIGADE AND BELOW (FBCB)</p>
<div style="border: 1px solid black; padding: 5px; width: fit-content; margin: 0 auto;">WARNING</div>
<p>Remove rings, bracelets, wristwatches, neck chains, and any other jewelry before working around vehicle. Jewelry may catch on equipment or may short across an electrical circuit. Failure to comply may result in serious injury or death to personnel.</p>
<p>Step (1). Check to see if circuit breaker (CB8) is tripped.</p>
<ul style="list-style-type: none"> (a) Remove wing screw from power distribution shelf. (b) Loosen wing screw on electrical distribution block cover. (c) Remove electrical distribution block cover from power distribution shelf.
<p>1c03u011</p>
<p>(d) Check to see if circuit breaker (CB8) is tripped.</p>
<p>1C03U061</p>
<p>If circuit breaker (CB8) is tripped, push reset button in to reset.</p>
<p>If circuit breaker (CB8) trips again, notify Unit Maintenance.</p>

Table 3-2. Troubleshooting (Cont)

MALFUNCTION	TEST OR INSPECTION	CORRECTIVE ACTION
u. SPECIAL PURPOSE KIT (CONT)		
u6.	NO POWER TO SINGGAR/FORCE XXI BATTLE COMMAND BRIGADE AND BELOW (FBCB) (CONT)	<p>Step (2). Check to see if SINGGAR/Force XXI Battle Command Brigade and Below (FBCB) has power.</p> <p>If SINGGAR/FBCB dos not have power, notify Unit Maintenance.</p> <ul style="list-style-type: none"> (a) Position electrical distribution block cover on power distribution shelf. (b) Tighten wing screw on electrical distribution block cover. (c) Install wing screw on power distribution shelf.
u7.	NO POWER TO MOBILE TRACKING SYSTEM (MTS)	<div style="text-align: center; border: 1px solid black; padding: 5px; width: fit-content; margin: 0 auto;">WARNING</div> <p>Remove rings, bracelets, wristwatches, neck chains, and any other jewelry before working around vehicle. Jewelry may catch on equipment or may short across an electrical circuit. Failure to comply may result in serious injury or death to personnel.</p> <p>Step (1). Check to see if circuit breaker (CB10) is tripped.</p> <ul style="list-style-type: none"> (a) Remove wing screw from power distribution shelf. (b) Loosen wing screw on electrical distribution block cover. (c) Remove electrical distribution block cover from power distribution shelf.
<p>The diagram illustrates the process of removing the electrical distribution block cover. It shows a side view of a metal structure with a shelf. An electrical distribution block cover is mounted on the shelf. Two wing screws are shown: one on the left side of the cover and one on the right side of the shelf. Arrows point from the labels to the corresponding parts in the diagram.</p>		
1c03u011		

Table 3-2. Troubleshooting (Cont)

MALFUNCTION	TEST OR INSPECTION	CORRECTIVE ACTION
u7.	NO POWER TO MOBILE TRACKING SYSTEM (MTS) (CONT)	(d) Check to see if circuit breaker (CB10) is tripped.
If circuit breaker (CB10) is tripped, push reset button in to reset.		
If circuit breaker (CB10) trips again, notify Unit Maintenance.		
Step (2). Check to see if Mobile Tracking System (MTS) has power.		
If MTS does not have power, notify Unit Maintenance.		
(a) Position electrical distribution block cover on power distribution shelf.		
(b) Tighten wing screw on electrical distribution block cover.		
(c) Install wing screw on power distribution shelf.		
u8.	DELETED.	
u9.	DELETED.	
u10.	DELETED.	
u11.	DELETED.	
u12.	DELETED.	
u13.	DELETED.	
u14.	DELETED.	

Table 3-2. Troubleshooting (Cont)

MALFUNCTION	TEST OR INSPECTION	CORRECTIVE ACTION
u. SPECIAL PURPOSE KIT (CONT)		
u15.	DELETED.	
u16.	DELETED.	
u17.	TROOP TRANSPORT ALARM DOES NOT OPERATE.	Notify Unit Maintenance.
u18.	LIGHT MATERIAL HANDLING CRANE (LMHC) DOES NOT OPERATE.	Check circuit breaker to see if it tripped (para 2-24b). If LMHC still does not operate, notify Unit Maintenance.
u19.	LIGHT MATERIAL HANDLING CRANE (LMHC) HOIST IN DOES NOT OPERATE.	Notify Unit Maintenance.
u20.	LIGHT MATERIAL HANDLING CRANE (LMHC) HOIST OUT DOES NOT OPERATE.	Notify Unit Maintenance.
v. CAB TILT AND SPARE TIRE RETAINER		
v1.	CAB DOES NOT RAISE.	Step 1. Check hydraulic oil level in air/hydraulic power unit (Appendix F). If hydraulic oil level is low, add hydraulic oil (Appendix F). Step 2. Check hydraulic hoses, air lines, and fittings for Class III leaks. If Class III leaks are found or cab tilt still does not raise or lower properly, notify Unit Maintenance.
v2.	CAB DOES NOT LOWER.	Step 1. Check hydraulic oil level in air/hydraulic power unit (Appendix F). If hydraulic oil level is low, add hydraulic oil (Appendix F). Step 2. Check hydraulic hoses, air lines, and fittings for Class III leaks. If Class III leaks are found or cab still does not lower, notify Unit Maintenance.
v3.	SPARE TIRE RETAINER DOES NOT RAISE.	Step 1. Check hydraulic oil level in air/hydraulic power unit (Appendix F). If hydraulic oil level is low, add hydraulic oil (Appendix F). Step 2. Check hydraulic hoses, air lines, and fittings for Class III leaks. If Class III leaks are found or spare tire retainer does not raise, notify Unit Maintenance.

Table 3-2. Troubleshooting (Cont)

MALFUNCTION
TEST OR INSPECTION
CORRECTIVE ACTION
<p>v4. SPARE TIRE RETAINER DOES NOT LOWER.</p> <p>Step 1. Check hydraulic oil level in air/hydraulic power unit (Appendix F). If hydraulic oil level is low, add hydraulic oil (Appendix F).</p> <p>Step 2. Check hydraulic hoses, air lines, and fittings for Class III leaks. If Class III leaks are found or spare tire retainer still does not lower, notify Unit Maintenance.</p>
<p>w. FRAME TROUBLESHOOTING</p>
<p>w1. TIRES CONTINUE TO WEAR AFTER FRONT END ALIGNMENT AND/OR VEHICLE DRIVES SIDEWAYS DOWN ROAD.</p> <p>Notify Unit Maintenance.</p>

Section III. MAINTENANCE PROCEDURES

3-4. INTRODUCTION

This section contains instructions for servicing, installing, and removing components at the Operator maintenance level.

3-5. CHANGING TIRE

This task covers:

- | | |
|---------------------|--------------------------|
| a. Lower Spare Tire | c. Tire Installation |
| b. Tire Removal | d. Tire Stowage |
| | e. Follow-On Maintenance |

INITIAL SETUP

Equipment Conditions

- Vehicle parked on level ground.
- Engine shut down (para 2-21f).
- Wheels chocked (para 2-21h).
- Cab raised (para 2-22a).

Tools and Special Tools (Cont)

- Wrench, Socket (Item 20, Appendix B)
- Wrench, Adjustable (Item 18, Appendix B)

Tools and Special Tools

- Jack, Hydraulic (Item 9, Appendix B)

Personnel Required

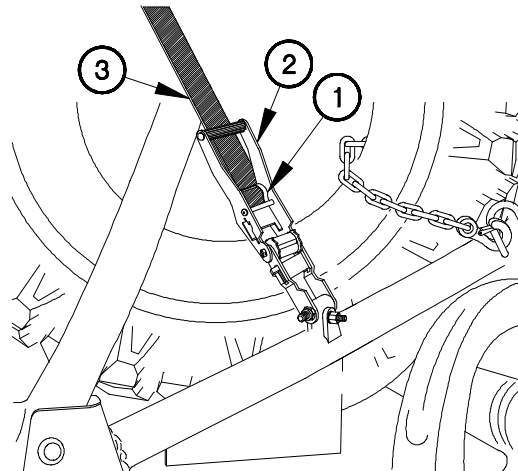
- (2)

a. Lower Spare Tire

WARNING

Ensure vehicle is parked on level ground before changing flat tire. Vehicle may roll. Failure to comply may result in serious injury or death to personnel.

- (1) Release latch (1) on ratchet (2).
- (2) Lift ratchet (2) and release strap (3).
- (3) Remove strap (3) from ratchet (2).



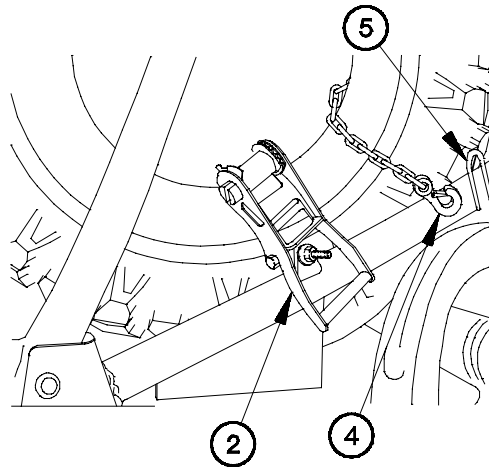
1C05A01A

- (4) Disconnect safety chain (4) from spare tire retainer (5).

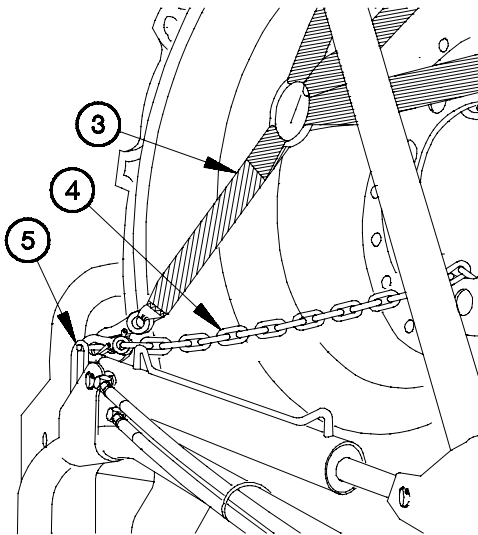
CAUTION

Ratchet must be in the closed position before cab is lowered. Failure to comply may result in damage to equipment.

- (5) Place ratchet (2) in closed position.



1C05A02A



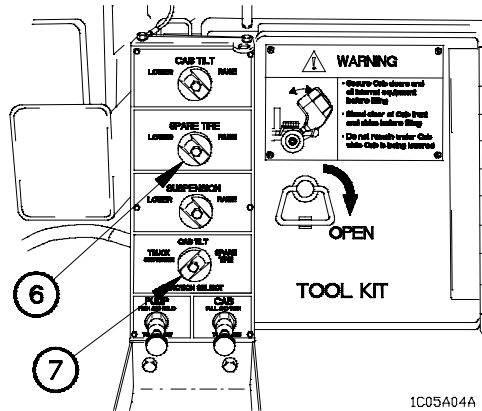
1C05A03A

- (6) Remove strap (3) and safety chain (4) from spare tire retainer (5).
- (7) Lower cab (para 2-22b).



3-5. CHANGING TIRE (CONT)

- (8) Turn SPARE TIRE knob (6) to the LOWER position.
- (9) Turn FUNCTION SELECT knob (7) to the SPARE TIRE position.



1C05A04A

WARNING

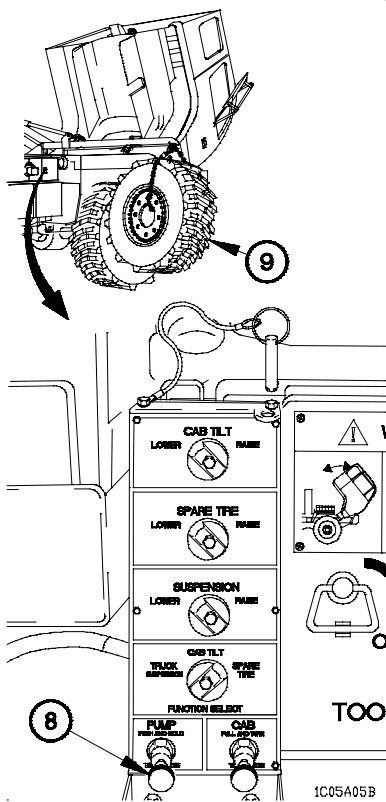
Tire weighs approximately 350 lbs (159 kgs). If treads of tire catch on tool box during lowering, raise tire and pull tire away from tool box and continue lowering. Use extreme care when lowering or handling tire. Failure to comply may result in injury to personnel.

CAUTION

Use caution when lowering tire to prevent damage to CTIS wheel valve. Failure to comply may result in damage to equipment.

NOTE

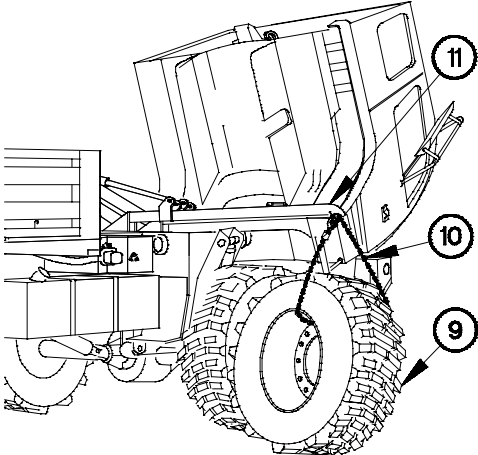
Use backup hydraulic pump (para 2-41) if pressing PUMP knob does not accomplish step (10).



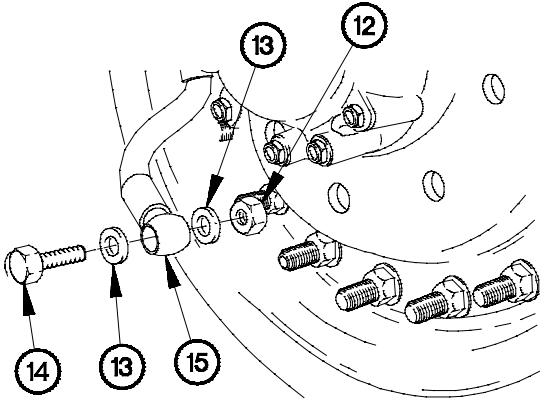
1C05A05B

- (10) Press and hold PUMP knob (8) to lower spare tire (9) to ground.

- (11) Disconnect one end of chain (10) from spare tire retainer lift arm (11).
- (12) Pull chain (10) through hole in spare tire (9).
- (13) Hook chain (10) to spare tire retainer lift arm (11).



1C05A06B



- (14) Remove nut (12), two washers (13), and bolt (14) from CTIS hose (15).

1C05A07A

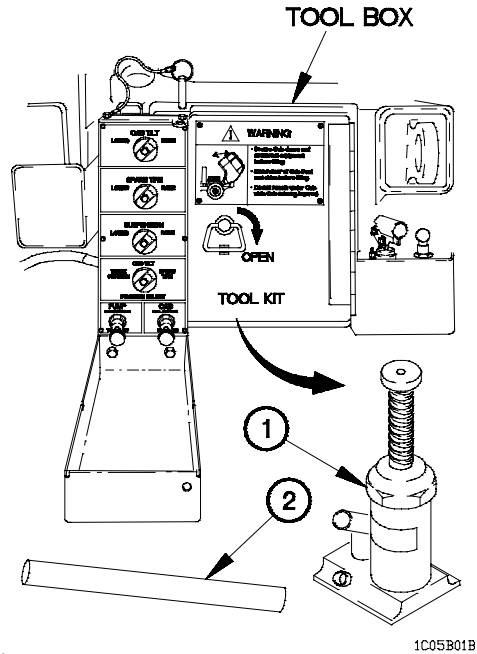
3-5. CHANGING TIRE (CONT)

b. Tire Removal.

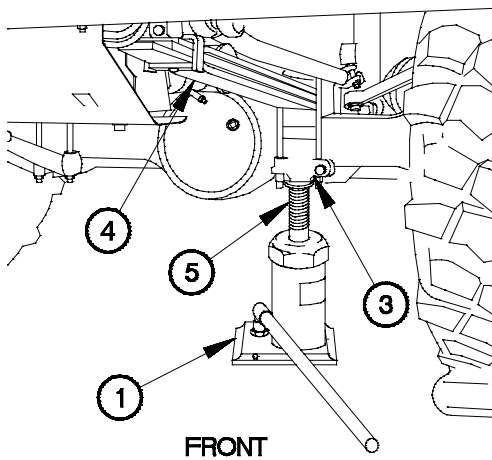
WARNING

Place hydraulic jack on flat surface. Do not allow personnel under vehicle when jacking. Failure to comply may result in serious injury or death to personnel.

- (1) Remove hydraulic jack (1) and handle (2) from tool box.



1C05B01B



1C05B02A

NOTE

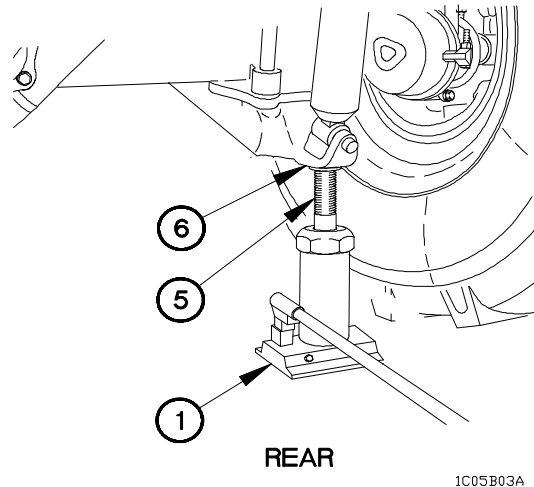
Perform steps (2) and (3) when removing front tire.

- (2) Position hydraulic jack (1) under saddle (3) of leaf spring (4).
- (3) Unscrew jack ram (5) until it touches saddle (3).

NOTE

Perform steps (4) and (5) when removing rear tire.

- (4) Position hydraulic jack (1) under inside bolt head on shock mount (6).
- (5) Unscrew jack ram (5) until it touches shock mount (6).

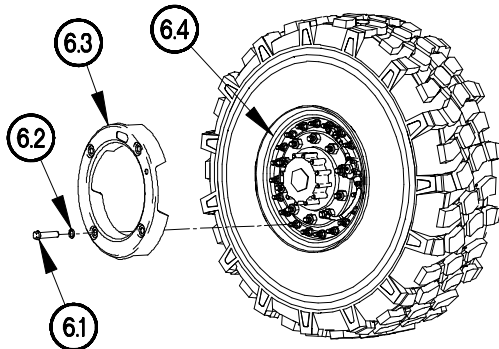


1C05B03A

NOTE

Perform the following step on vehicles equipped with rim covers.

- (5.1) Remove four bolts (6.1), washers (6.2), and rim cover (6.3) from wheel (6.4).

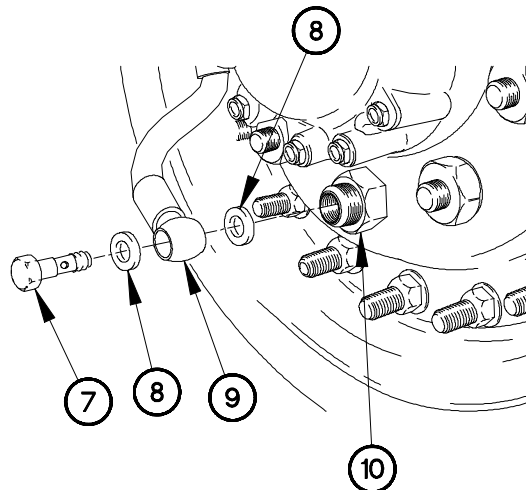


1C05B081

NOTE

- Both front and rear tires are removed the same way. Rear tire shown.
- Air will not escape when CTIS hose is removed from hollow wheel stud.

- (6) Remove banjo bolt (7), two washers (8), and CTIS hose (9) from hollow wheel stud (10).



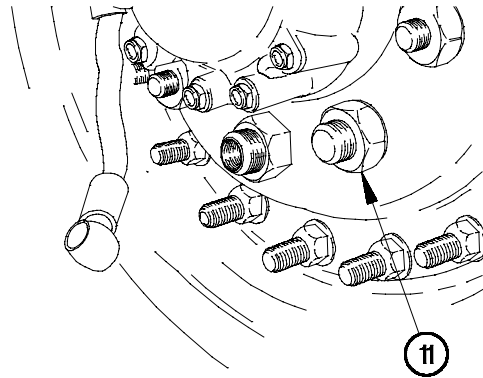
1C05B04A

3-5. CHANGING TIRE (CONT)

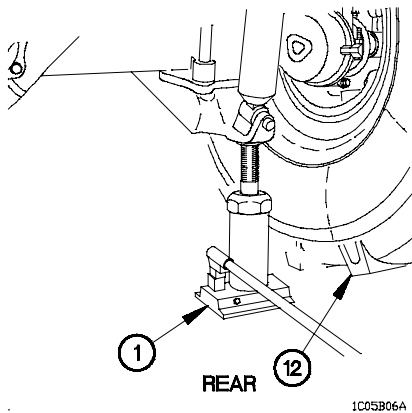
NOTE

- Studs and lugnuts on left side of vehicle have left-hand threads. Turn lugnuts to right to loosen, and to left to tighten.
- Studs and lugnuts on right side of vehicle have right-hand threads. Turn lugnuts to left to loosen, and to right to tighten.

(7) Loosen ten lugnuts (11).



1C05B05A



(8) Raise hydraulic jack (1) until tire (12) is off ground.

WARNING

Tire weighs approximately 350 lbs (159 kgs). Use extreme care when handling tire. Failure to comply may result in injury to personnel.

- (9) Remove ten lugnuts (11) from studs (13).

CAUTION

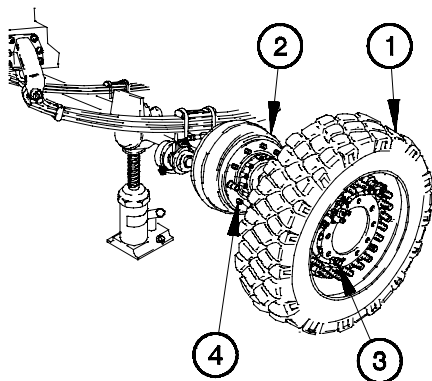
Do not drag tire across studs during removal. Failure to comply may result in damage to equipment.

NOTE

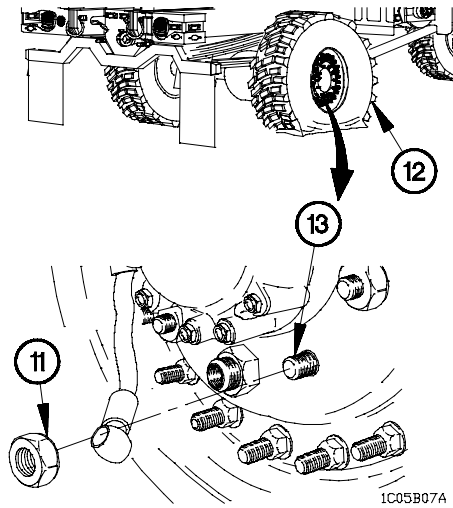
Step (10) requires the aid of an assistant.

- (10) Remove tire (12) from studs (13).

c. Tire Installation.



1C05C01A



1C05B07A

NOTE

- Steps (1) through (5) require the aid of an assistant.
- Front and rear tires are installed the same way. Rear tire installation shown.

- (1) Roll tire (1) up to hub (2).
- (2) Align CTIS hose (3) with hollow wheel stud (4).

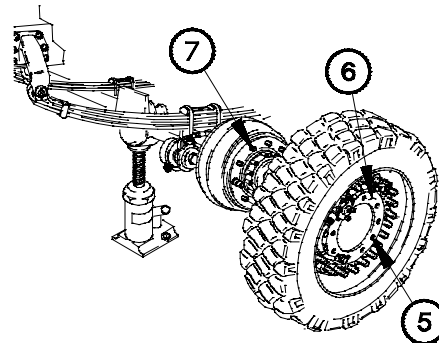
3-5. CHANGING TIRE (CONT)

- (3) Align ten holes (5) in wheel (6) with studs (7).

CAUTION

Do not drag tire across studs or crossthread lugnuts. Failure to comply may result in damage to equipment.

- (4) Install wheel (6) on studs (7).



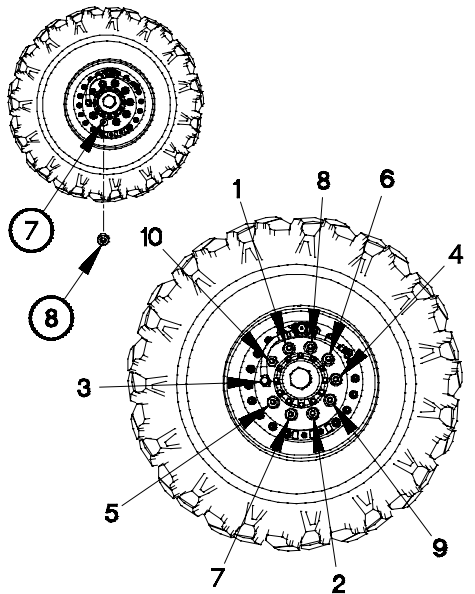
1C05C02A

WARNING

Notify Unit Maintenance that lugnuts must be tightened to 425-475 lb-ft (576-644 N•m) as soon as possible. Tire may come loose if lugnuts are not tightened to proper torque. Failure to comply may result in serious injury or death to personnel.

NOTE

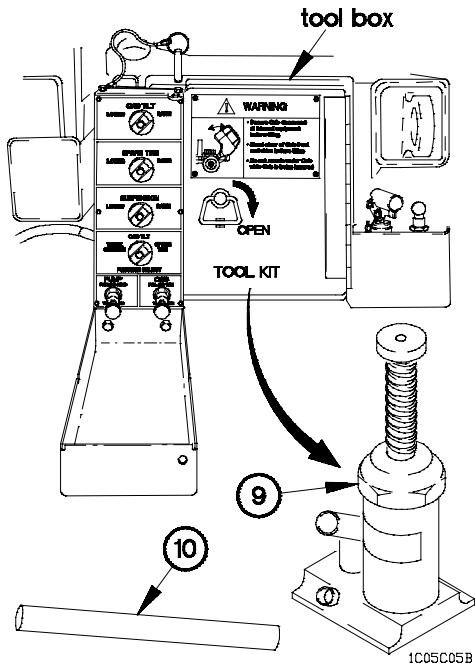
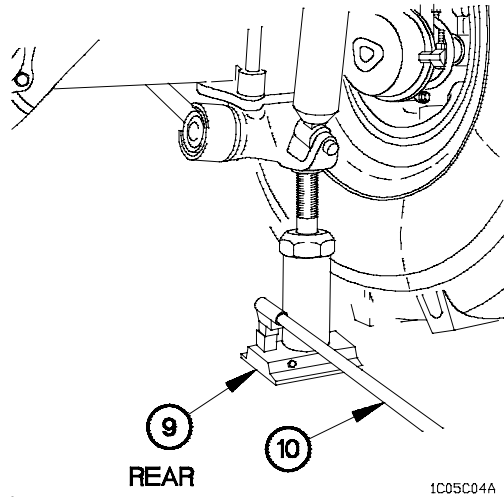
- Studs and lugnuts on left side of vehicle have left-hand threads. Turn lugnuts to right to loosen, and to left to tighten.
 - Studs and lugnuts on right side of vehicle have right-hand threads. Turn lugnuts to left to loosen, and to right to tighten.
- (5) Install ten lugnuts (8) on studs (7) in sequence shown.



TIGHTENING SEQUENCE

1C05C03A

- (6) Lower vehicle to ground with hydraulic jack (9).
- (7) Remove hydraulic jack (9) and handle (10) from vehicle.



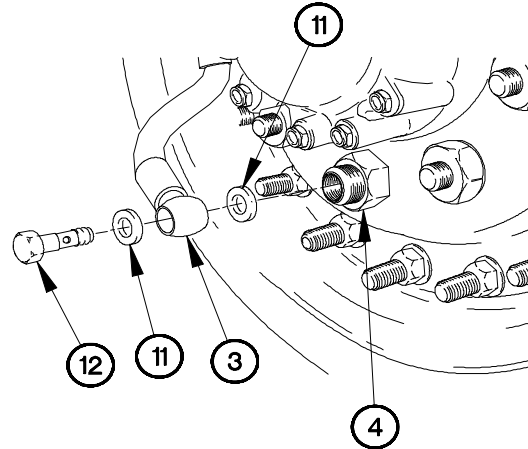
- (8) Stow hydraulic jack (9) and handle (10) in tool box.

3-5. CHANGING TIRE (CONT)

CAUTION

Do not over tighten banjo bolt when installing CTIS hose on hollow wheel stud. Failure to comply may result in damage to equipment.

- (9) Install CTIS hose (3) on hollow wheel stud (4) with two washers (11) and banjo bolt (12).



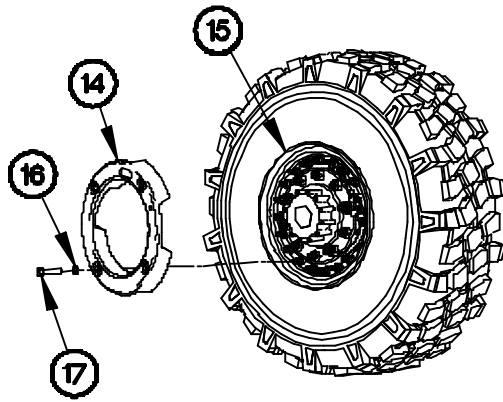
1C05C06A

NOTE

Slotted hole in rim cover is aligned with pressure valve extension.

- (10) Position rim cover (14) on wheel (15) with four washers (16) and bolts (17).

- (11) Notify Unit Maintenance to torque four rim cover bolts to 71-95 lb-ft (96-128 N·m).



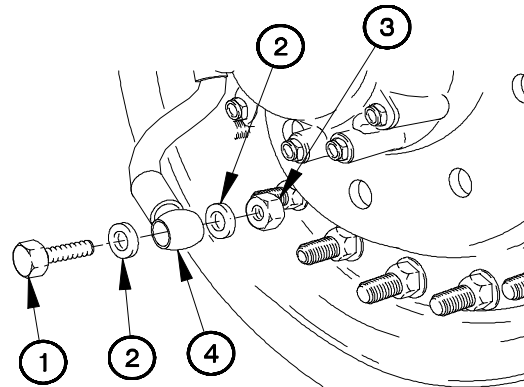
1C05C071

d. Tire Stowage.

WARNING

- Handle tire with care. Tire may have exposed broken metal cords or sharp debris in it. Failure to comply may result in injury to personnel.
- Tire weighs approximately 350 lbs (159 kgs). Use extreme care when handling tire. Failure to comply may result in injury to personnel.

- (1) Install bolt (1), two washers (2) and nut (3) in CTIS hose (4).

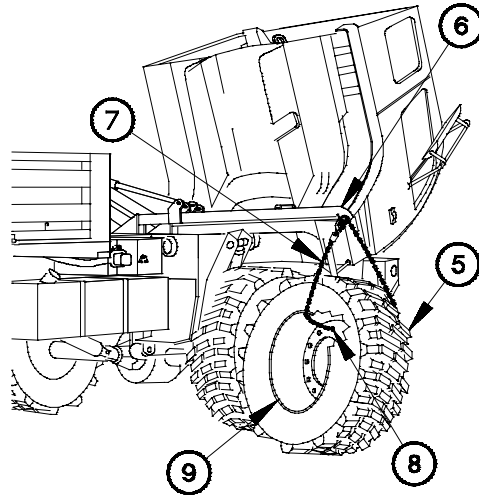


1C05D01A

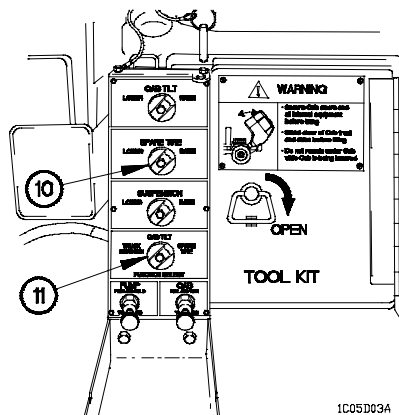
- (2) Roll flat tire (5) under center of spare tire retainer lift arm (6).
- (3) Disconnect one end of chain (7) from spare tire retainer lift arm (6).

NOTE

- CTIS valve on tire must be positioned to the front of vehicle and at the 6 o'clock position.
 - Flat tire should be straight up and down when installing chain through lug hole.
- (4) Route chain (7) through uppermost lug hole (8) in wheel (9).
 - (5) Connect chain (7) to spare tire retainer lift arm (6).



1C05D02B



1C05D034

CAUTION

Use caution when raising tire to prevent damage to CTIS valve. Failure to comply may result in damage to equipment.

- (6) Raise cab (para 2-22a).
- (7) Turn SPARE TIRE knob (10) to the RAISE position.
- (8) Turn FUNCTION SELECT knob (11) to the SPARE TIRE position.

3-5. CHANGING TIRE (CONT)

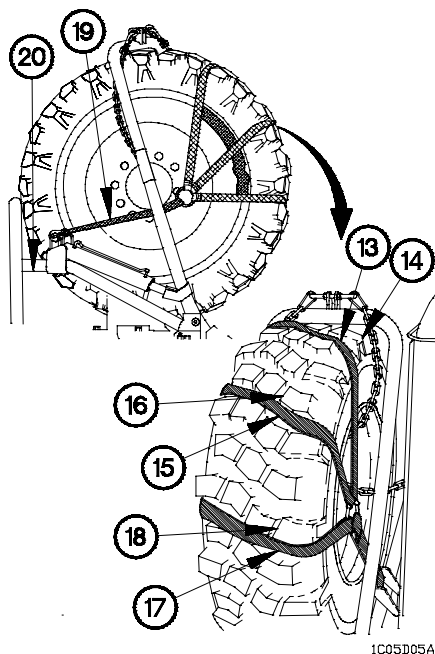
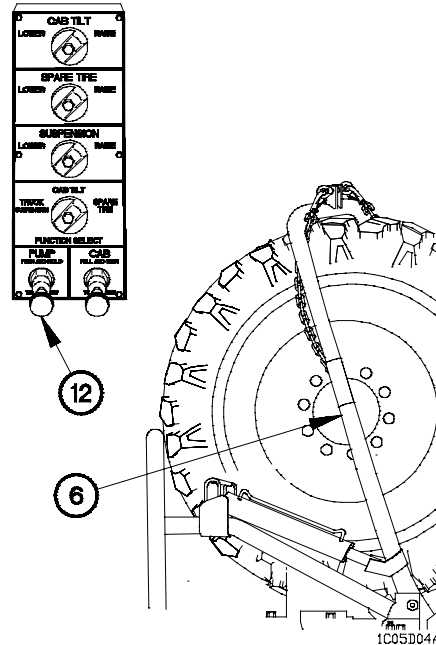
CAUTION

Tire must be stowed against back frame of spare tire retainer (for all models except Air Drop vehicles). Failure to comply may result in damage to equipment.

NOTE

Use backup hydraulic pump (para 2-41) if pressing PUMP knob does not accomplish step (9).

- (9) Press and hold PUMP knob (12) to raise spare tire retainer lift arm (6) to the stowed position.



CAUTION

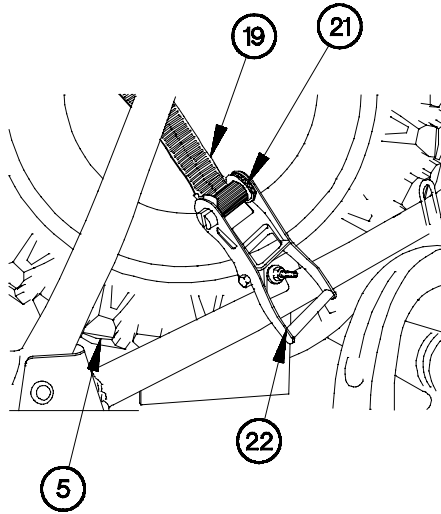
- Tread engagers must be in slots of tire treads. A loose strap will allow tire to move causing chafing of strap and possible loss of tire. Failure to comply may result in damage to equipment.
 - Tread engagers must not be snug at installation for proper fit, but strap must have a tight fit. Failure to comply may result in damage to equipment.
- (10) Position tread engager (13) in third tread (14), tread engager (15) in sixth tread (16), and tread engager (17) in ninth tread (18).
 - (11) Connect strap (19) to spare tire retainer (20).

- (12) Feed other end of strap (19) through ratchet (21).

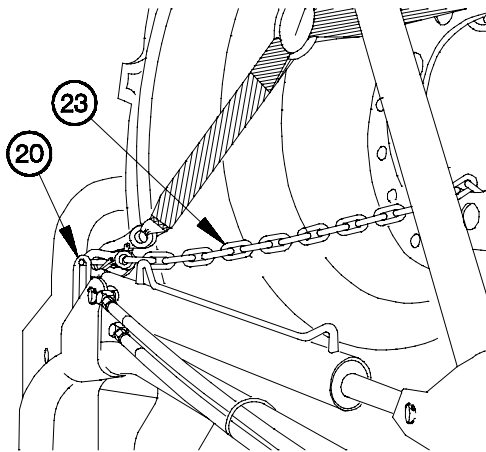
CAUTION

Ensure that strap is wrapped around ratchet at least three complete wraps after tightening. Failure to comply may result in damage to equipment.

- (13) Tighten strap (19) around flat tire (5) with ratchet (21) and close latch (22).



1C05D06A



1C05D07A

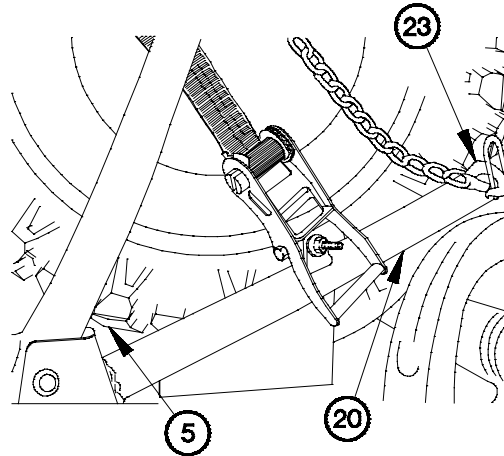
CAUTION

Ensure that safety chain is loose. If safety chain is tight then strap is not tight enough. Failure to comply may result in damage to equipment.

- (14) Connect safety chain (23) to spare tire retainer (20).

3-5. CHANGING TIRE (CONT)

- (15) Route other end of safety chain (23) through flat tire (5) and connect to spare tire retainer (20).
- (16) Lower cab (para 2-22b).



f. Follow-On Maintenance.

- (1) Remove wheel chocks (para 2-21h).
- (2) Notify Unit Maintenance that lugnuts need to be tightened to 425-475 lb-ft (576-644 N•m).
- (3) Notify Unit Maintenance that flat tire needs to be repaired/replaced.
- (4) Notify Unit Maintenance if flat tire was replaced on front of vehicle that kneeling valve must be installed.
- (5) Notify Unit Maintenance that banjo bolts need to be tightened to 22-28 lb-ft (30-38 N•m).

End of Task.

3-6. SERVICING TIRES	
This task covers:	
a. Checking Tire Pressures	b. Manually Inflating Tires
INITIAL SETUP	
Equipment Conditions Engine shut down (para 2-21f).	Tools and Special Tools Inflator-Gage, Tire W/Hose (Item 8, Appendix B)
Personnel Required (2)	

WARNING

Ensure tires have correct tire pressure (within ± 3 psi (21 kPa)) for terrain conditions and driving speed (refer to Table 3-3). Failure to comply may result in serious injury or death to personnel.

a. Checking Tire Pressures.

Check tire pressures with tire inflator-gage.

Table 3-3. Cold Tire Inflation Pressures and Restrictions

Operating Mode	Maximum Vehicle Speed	Operating Time Restriction	Tire Pressure
Highway	55 mph (88 km/h)	NONE	55 psi (379 kPa)
Cross-Country	40 mph (64 km/h)	NONE	33 psi (228 kPa)
Sand	12 mph (19 km/h)	NONE	20 psi (138 kPa)
Emergency	5 mph (8 km/h)	10 MINUTES	14 psi (97 kPa)

3-6. SERVICING TIRES (CONT)

b. Manually Inflating Tires.

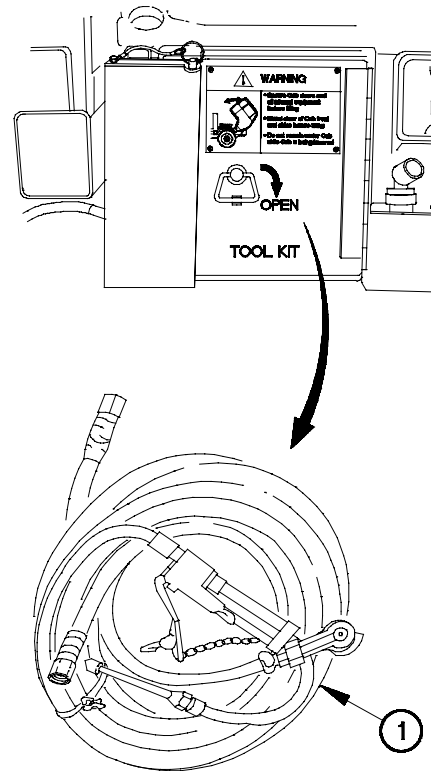
WARNING

Use caution when inflating tire. Overinflation may cause tire to blow apart. Failure to comply may result in serious injury or death to personnel or damage to equipment.

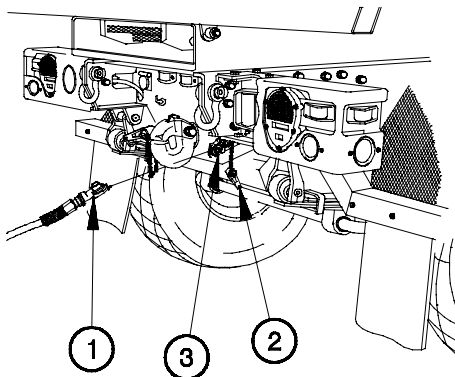
NOTE

- If CTIS is not working, tires may be inflated manually. Tires should be inflated when they are cool. Inflate to proper pressure for terrain conditions and driving speed. Refer to Table 3-3.
- Gladhands at rear of vehicle are used to manually inflate tires.

(1) Remove tire inflator-gage and hose (1) from TOOL KIT.



1C06B01A



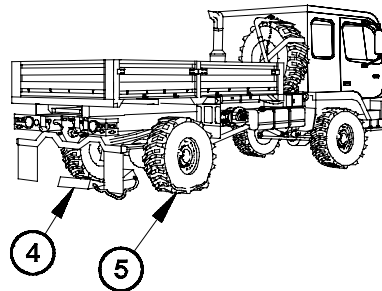
1C06B02A

- (2) Remove dummy coupling (2) from SERVICE or EMERGENCY gladhand (3) at rear of vehicle.
- (3) Connect tire inflator-gage and hose (1) to SERVICE or EMERGENCY gladhand (3).
- (4) Start engine (para 2-21a or b).

WARNING

Wheels must be chocked and service brakes applied before parking brake is released. Vehicle may roll if wheels are not chocked. Failure to comply may result in serious injury or death to personnel.

- (5) Install two wheel chocks (4) against tire across from tire (5) that is to be inflated.

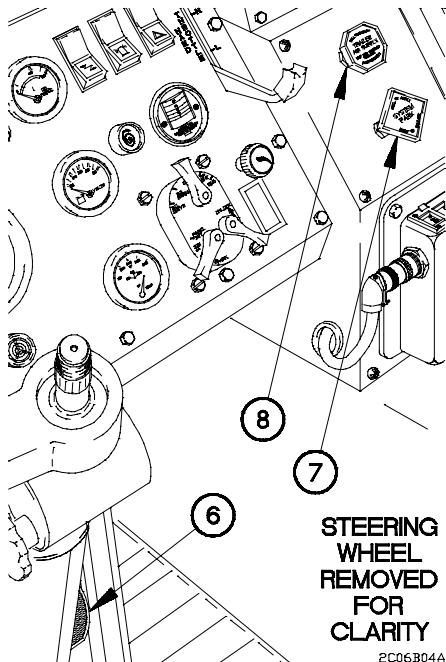


1C06B03A

NOTE

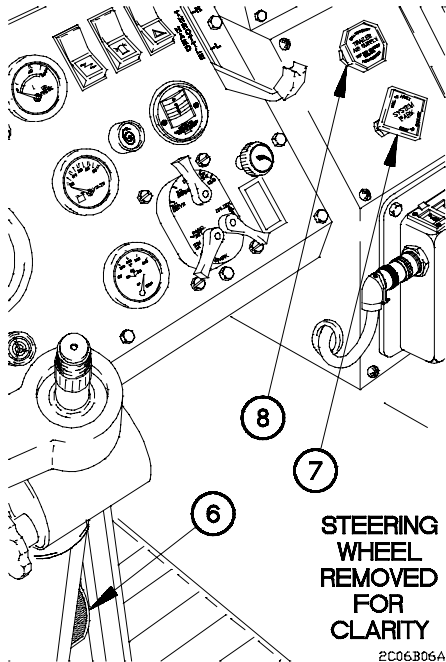
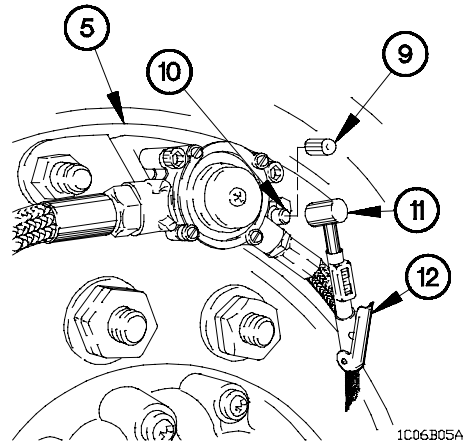
- Air is available at rear gladhands as long as brake pedal is applied.
- Steps (6) through (14) require the aid of an assistant.

- (6) Depress brake pedal (6).
- (7) Push in SYSTEM PARK control (7).
- (8) Push in TRAILER AIR SUPPLY control (8).



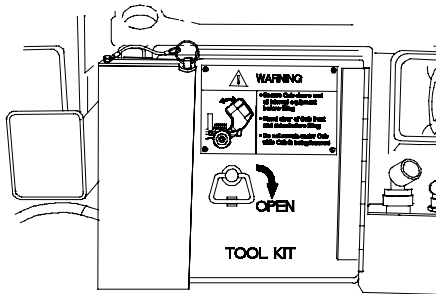
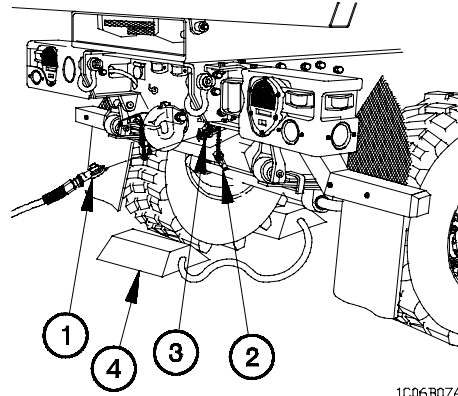
3-6. SERVICING TIRES (CONT)

- (9) Remove cap (9) from valve stem (10).
- (10) Press chuck of tire inflator gage (11) over valve stem (10) and squeeze handle (12).
- (11) Add air to tire (5) as required by Table 3-3.
- (12) Remove chuck of tire inflator gage (11) from valve stem (10).
- (13) Install cap (9) on valve stem (10).

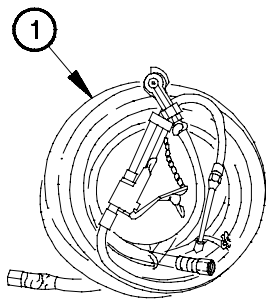


- (14) Pull out SYSTEM PARK control (7).
- (15) Pull out TRAILER AIR SUPPLY control (8).
- (16) Release brake pedal (6).
- (17) Shut down engine (para 2-21f).

- (18) Remove tire pressure gage and hose (1) from SERVICE or EMERGENCY gladhand (3).
- (19) Install dummy coupling (2) on SERVICE or EMERGENCY gladhand (3).
- (20) Remove two wheel chocks (4).



- (21) Stow tire inflator-gage and hose (1) in TOOL KIT.



End of Task.

3-7. CLEANING VEHICLE	
This task covers:	
a. Cleaning Exterior	b. Cleaning Interior
INITIAL SETUP	
Equipment Condition Wheels chocked (para 2-21h).	Materials/Parts Rags, Wiping (Item 17, Appendix D) Soap, Laundry (Item 18, Appendix D) Solvent, Dry Cleaning (Item 19, Appendix D)

WARNING

- All cleaning procedures must be accomplished in well-ventilated areas. Failure to comply may result in injury to personnel or damage to equipment.
- Protective gloves, clothing, and/or respiratory equipment must be worn whenever caustic, toxic, or flammable cleaning solutions are used. Failure to comply may result in injury to personnel or damage to equipment.
- Diesel fuel or gasoline must never be used for cleaning. Failure to comply may result in injury to personnel or damage to equipment.
- A fire extinguisher must be available and ready during all cleaning operations involving solvents. Failure to comply may result in injury to personnel or damage to equipment.
- Dry Cleaning Solvent (P-D-680) is TOXIC and flammable. Wear protective goggles and gloves; use only in well-ventilated area; avoid contact with skin, eyes, and clothes, and do not breath vapors. Keep away from heat or flame. Never smoke when using Dry Cleaning Solvent; the flashpoint for Type I Dry Cleaning Solvent is 100°F (38°C) and for Type II is 138°F (50°C). Failure to comply may result in serious injury or death to personnel.
- If personnel become dizzy while using Dry Cleaning Solvent, immediately get fresh air and medical help. If Dry Cleaning Solvent contacts skin or clothes, flush with cold water. If solvent contacts eyes, immediately flush eyes with water and get medical attention. Failure to comply may result in serious injury or death to personnel.

CAUTION

- Do not wipe dirt off vehicle when it is dry. Dirt, stones, or debris may scratch and damage vehicle. Failure to comply may result in damage to equipment.
- Use caution when washing around the engine compartment to prevent damage to sensors and inadvertent removal of grease in bearing surfaces. Failure to comply may result in damage to equipment.
- Periodically wash the engine side of the fan clutch in the engine compartment. Fine particles of road debris may accumulate in the fan clutch housing causing the fan clutch to drag and not fully release. Failure to comply may result in damage to equipment.
- Do not allow water to enter air cleaner inlet while washing vehicle. Air cleaner becomes restricted when wet and may cause a loss in engine power. Failure to comply may result in damage to equipment.
- Do not use high pressure water or steam on starting motor. When cleaning engine/transmission, starting motor must be protected from any high pressure water or steam. Failure to comply may result in damage to equipment.
- Do not direct high-pressure water stream at glass surfaces, seals, air intake, exhaust outlet, or any other component of vehicle that could be easily damaged by high-pressure water stream. Failure to comply may result in damage to equipment.
- Do not use high pressure water or steam to clean interior of vehicle. Failure to comply may result in damage to equipment.
- Do not use strong detergent or abrasive. Failure to comply result in damage to equipment.
- Do not allow cleaning compounds to come into contact with rubber, vinyl, or canvas materials. Failure to comply may result in damage to equipment.
- Do not allow corrosion-removing cleaning compounds to contact painted surfaces. Failure to comply may result in damage to equipment.

3-7. CLEANING VEHICLE (CONT)

CAUTION

- Do not use compressed air when cleaning cab interior. Failure to comply may result in damage to equipment.
- Do not steam clean any part of vehicle that has been rustproofed. Failure to comply may result in damage to equipment.
- Mildew must be removed with a bristle brush before canvas can be properly cleaned and aired. Failure to comply may result in damage to equipment.
- The radiator is always cleaned first from behind with low pressure water or air in order to blow debris, insects, or other obstructions out and away from the radiator core. Failure to comply may result in damage to equipment.

NOTE

- Detailed description of specific cleaning compounds, cleaning solvents, dry cleaning solutions, and corrosion-removing compounds are found in TM 9-247.
- Table 3-4 provides a general guideline to cleaning materials used in removing contaminants from various vehicle surfaces.

Table 3-4. General Cleaning Instructions

Cleaning Materials Used to Remove			
Surface	Oil/Grease	Salt/Mud/ Dust/Debris	Surface Rust/Corrosion
Body	Grease-cleaning compound, running water, and damp or dry rags.	High pressure water, soapy warm water, soft brush, and damp or dry rags.	Corrosion-removing compound, bristle brush, dry rags, and lubricating oil.*
Cab Interior (Metals)	Grease cleaning compound and damp or dry rags.	Damp and dry rags.	Corrosion-removing compound, bristle brush, dry rags, and lubricating oil.*
* After cleaning, apply light grade of lubricating oil to all unprotected surfaces to prevent continued rust.			

Table 3-4. General Cleaning Instructions (Cont)

Cleaning Materials Used to Remove			
Surface	Oil/Grease	Salt/Mud/ Dust/Debris	Surface Rust/Corrosion
Cab Interior (Material)	Saddle soap, warm water, soft brush, and dry rags.	Soft brush, soapy warm water, and damp or dry rags.	Not applicable.
Frame	Grease-cleaning compound rinsed with running water and rags.	High pressure water, soapy warm water, wire brush, and damp or dry rags.	Corrosion-removing compound, bristle brush, dry rags, and lubricating oil.*
Starting Motor	Mixed solution, 1 part grease-cleaning compound, 4 parts dry cleaning solvent, and rags.	Soapy warm water, soft wire brush, and damp or dry rags.	Bristle brush, warm soapy water, and dry rags.
Engine/ Transmission	Mixed solution, 1 part grease-cleaning compound, 4 parts dry cleaning solvent, and rags.	High pressure water, soapy warm water, soft wire brush, and damp or dry rags.	Bristle brush, warm soapy water, and dry rags.
Glass	Glass cleaning solution and clean dry rags.	Glass cleaning solution and clean, dry rags.	Not applicable.
Radiator	Not applicable.	Low pressure water, air, soapy warm water, and damp or dry rags.	Not applicable.
Rubber Insulation	Damp or dry rags.	Damp or dry rags.	Not applicable.
Tires	Soapy water and bristle brush.	High pressure water and bristle brush.	Not applicable.
Cable	Cleaning compound and wire brush.	Wire brush.	Wire brush and lubricating oil.*
* After cleaning, apply light grade of lubricating oil to all unprotected surfaces to prevent continued rust.			

3-7. CLEANING VEHICLE (CONT)

a. Cleaning Exterior.

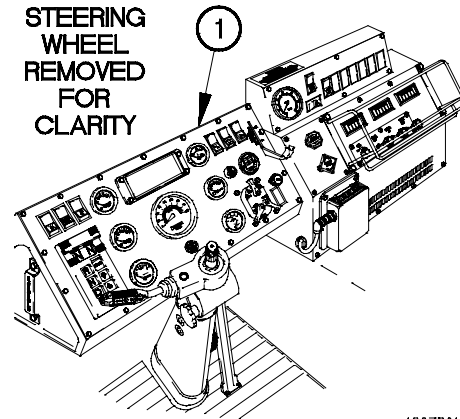
Wash vehicle per table 3-4 General Cleaning Instructions.

b. Cleaning Interior.

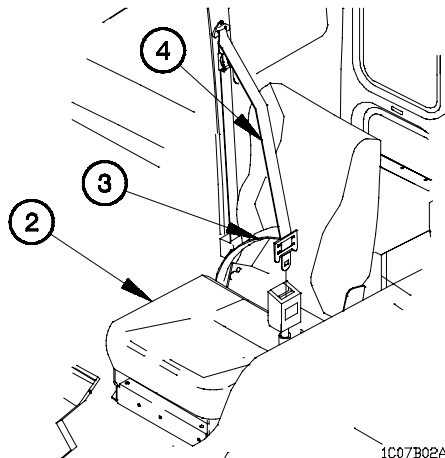
CAUTION

Do not allow water to contact electrical controls, gages, or indicators. Failure to comply may result in damage to equipment.

- (1) Remove loose dirt and dust from instrument panel (1) with damp wiping rag.



1C07B011



1C07B02A

- (2) Clean seat cushions (2), seat belts (3), and shoulder harnesses (4) with warm soapy water.
- (3) Wipe seat cushions (2), seat belts (3), and shoulder harnesses (4) dry with wiping rags.

NOTE

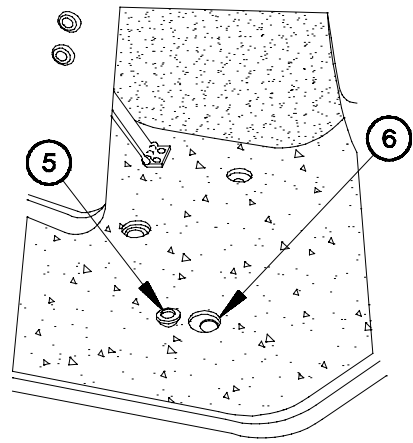
Both left and right side drain plugs are removed/ installed the same. Left side shown.

- (4) Remove six drain plugs (5) from floor (6).

CAUTION

Do not use water to clean instrument panel area, especially under instrument panel. Failure to comply may result in damage to equipment.

- (5) Using a low pressure hose, wash mud, sand, or dirt from floor (6).
- (6) Wipe excess water from floor (6) with wiping rags.
- (7) Install six drain plugs (5) in floor (6).



End of Task.

3-8. OPENING BATTERY BOX/TESTING BATTERIES

This task covers:

- a. Opening Battery Box
- b. Testing Batteries
- c. Closing Battery Box

INITIAL SETUP

Equipment Conditions

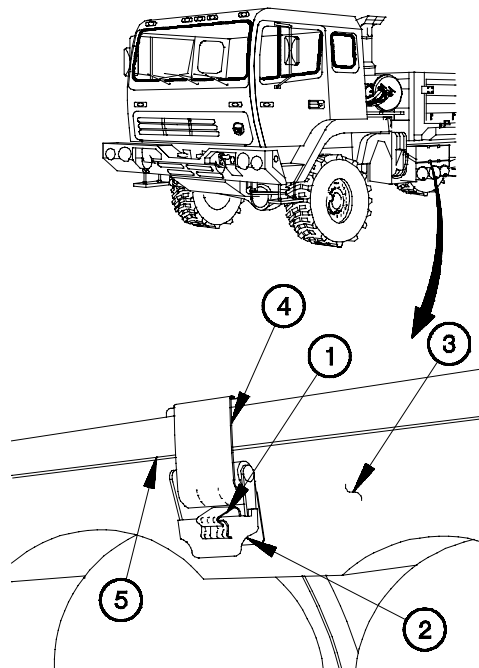
Engine shut down (para 2-21f).

Materials/Parts

Rags, Wiping (Item 17, Appendix D)

a. Opening Battery Box.

- (1) Lift two spring catches (1) and latch levers (2) from battery box (3).
- (2) Release latches (4) from battery box cover (5).
- (2) Remove battery box cover (5) from battery box (3).



1C08A01A

b. Testing Batteries.

- (1) Start engine (para 2-21a).
- (2) Shut down engine after idling for approximately four minutes (para 2-21f).

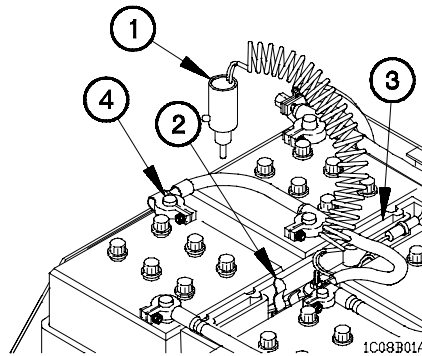
WARNING

- Lead-acid battery gases can explode. Do not smoke, have open flames, or make sparks around a battery, especially if caps are off. Battery may give off gas which can explode. Failure to comply may result in serious injury or death to personnel.
- Remove all rings, bracelets, wristwatches, neck chains, and other jewelry before working around vehicle. Jewelry may catch on equipment or may short across an electrical circuit or battery terminal. Failure to comply may result in serious injury or death to personnel.

- (3) Remove battery tester (1) from clamp (2) on battery tray (3).

NOTE

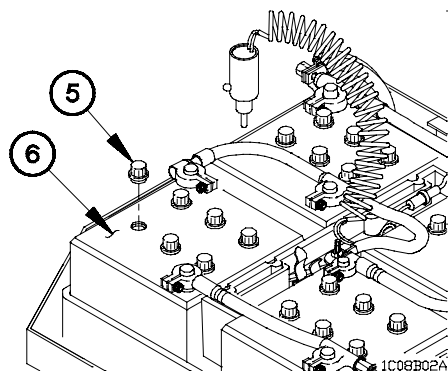
If battery tester red light illuminates then battery tester is operational. If red light does not illuminate notify Unit Maintenance.



- (4) Check operation of battery tester (1) by touching tip of battery tester (1) to positive battery post (4).

NOTE

All four batteries can be checked the same way. Check inside cells of inside batteries first, outside cells of outside batteries last. Left front battery shown.



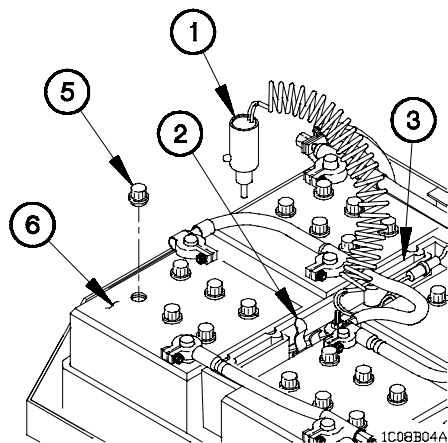
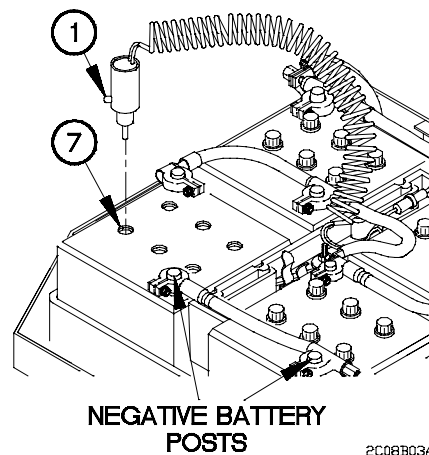
- (5) Remove battery fill caps (5) from battery (6).

3-8. OPENING BATTERY BOX/TESTING BATTERIES (CONT)

NOTE

- If red light illuminates before inserting battery tester all the way in fill hole, battery may be overfilled.
- Red light may flash intermittently as battery tester is inserted in fill hole.
- With battery tester inserted fully into the fill hole adjacent to the negative battery posts of the outside batteries, the red light may illuminate briefly then go out, if the electrolyte is at proper level.
- With battery tester inserted fully in fill hole, red light will illuminate if electrolyte is at its proper level.
- If red light does not illuminate, or if cell is overfilled, notify Unit Maintenance that battery requires servicing.

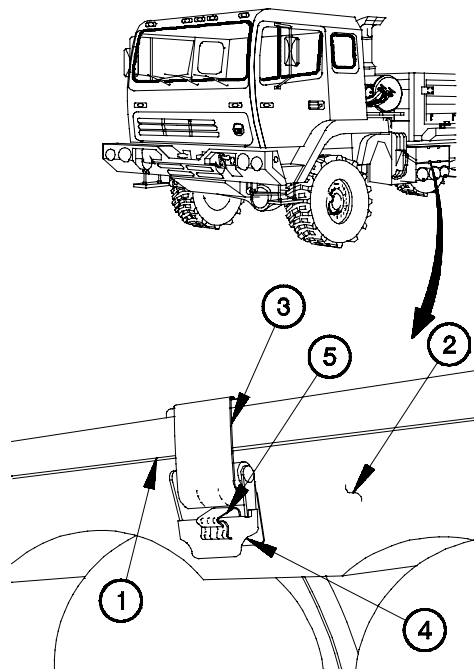
- (6) Place battery tester (1) in fill hole (7).
- (7) Check battery tester (1) for red light.
- (8) Remove battery tester (1) from fill hole (7).



- (9) Install battery fill caps (5) on battery (6).
- (10) Wipe tip of battery tester (1) clean of any fluid with wiping rag.
- (11) Install battery tester (1) in clamp (2) on battery tray (3).

c. Closing Battery Box.

- (1) Position battery box cover (1) on battery box (2).
- (2) Fasten two latches (3) on battery box cover (1).
- (3) Push down on two latch levers (4) until spring catches (5) are engaged.



1C08C01A

End of Task.

3-9. SERVICING AIR FILTER (EMERGENCY PROCEDURE)

This task covers:

- a. Servicing
- b. Follow-On Maintenance

INITIAL SETUP

Equipment Conditions

Engine shut down (para 2-21f).
Wheels chocked (para 2-21h).

Materials/Parts

Rags, Wiping (Item 17, Appendix D)

WARNING

Nuclear, Biological, or Chemical (NBC) contaminated air filters must be handled and disposed of only by authorized and trained personnel. The unit commander or senior officer in charge of maintenance personnel must ensure that prescribed protective clothing (FM 3-4) is used, and prescribed safety measures and decontamination procedures (FM 3-5 and TB 700-4) are followed. The unit standard operating procedures are responsible for final disposal of contaminated air filters. Failure to comply may result in serious injury or death to personnel.

CAUTION

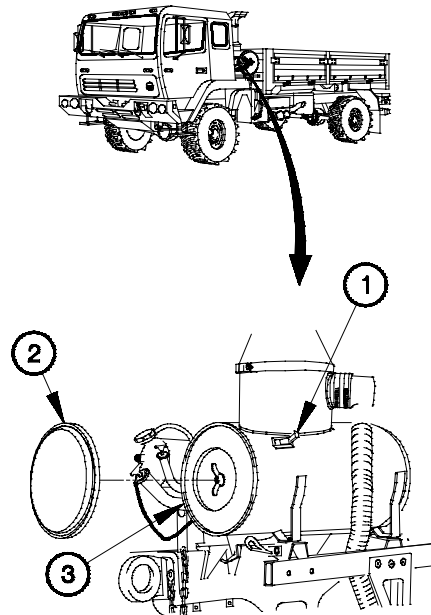
Do not operate engine without air filter installed. Failure to comply may result in damage to equipment.

NOTE

This is an emergency procedure and is only to be performed when AIR FILTER RESTRICTION GAUGE reads greater than 25 in. (64 cm) (in red area) while vehicle is on mission.

a. Servicing.

- (1) Unlatch three clasps (1) on cover (2).
- (2) Remove cover (2) from intake air cleaner housing (3).



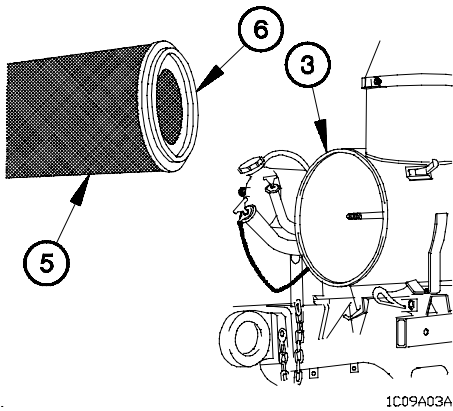
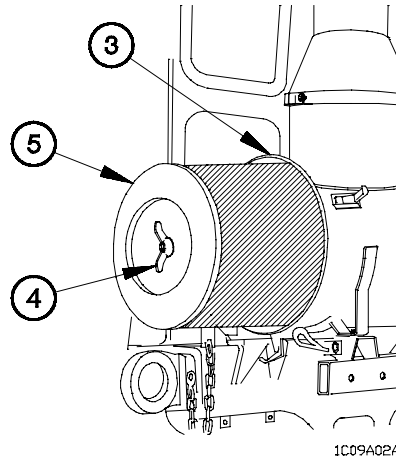
1C09A01A

- (3) Loosen wingnut (4) and remove filter element (5) from intake air cleaner housing (3).

CAUTION

Use extreme care when cleaning air filter element. Failure to comply may result in damage to equipment.

- (4) Gently tap filter element (5) on a flat hard surface to loosen dirt.



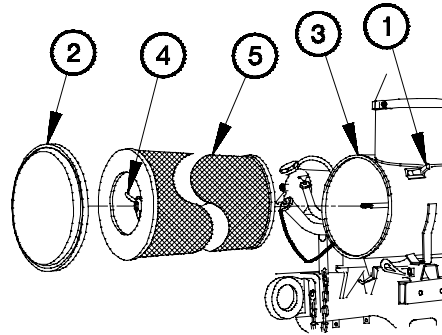
- (5) Clean filter element (5) with clean wiping rag to free trapped dirt.
- (6) Clean filter element gasket (6) with clean wiping rag.
- (7) Clean inside intake air cleaner housing (3) with clean wiping rag.

3-9. SERVICING AIR FILTER (CONT)

NOTE

Filter element is installed in intake air cleaner housing with gasket end first.

- (8) Position filter element (5) in intake air cleaner housing (3).
- (9) Tighten wingnut (4) on filter element (5).
- (10) Position cover (2) on intake air cleaner housing (3).
- (11) Latch three clasps (1).



1C09A04A

b. Follow-On Maintenance.

Start engine (para 2-21a or b) and check AIR FILTER RESTRICTION GAUGE. Notify Unit Maintenance if AIR FILTER RESTRICTION GAUGE still reads greater than 25 in. (64 cm) (in red area).

End of Task.

3-10. M1081 AIR DROP PREPARATION

This task covers:

- a. Spare Tire Stowage (Vehicles Not Equipped with Machine Gun Ring)
- b. Spare Tire Stowage (Vehicles Equipped with Machine Gun Ring).
- c. Cab Preparation
- d. Spare Tire Retainer and Davit Preparation
- e. Slide Assembly Installation
- f. Load Spreader Installation
- g. Follow-On Maintenance

INITIAL SETUP

Equipment Conditions

Vehicle parked on level ground.
 Engine shut down (para 2-21f).
 Wheels chocked (para 2-21h).
 Spare tire removed (para 3-5b) (Vehicles not equipped with machine gun ring).
 Side panels stowed (para 2-26f).

Tools and Special Tools

Wrench Assembly, Speedhandle (Item 6 (COEI), Appendix B)
 Wrench, Adjustable, 8 in. (Item 16, Appendix B)

Tools and Special Tools

Strap Assembly (Item 5 (COEI), Appendix B)
 Sling Assembly, Air Drop Roof (Item 4 (COEI), Appendix B)
 Crane, Light Material Handling, Kit 1500 lb Capacity (Appendix C) (Vehicles equipped with machine gun ring)
 Crane Adapter Kit (Appendix C) (Vehicles equipped with machine gun ring)

Personnel Required

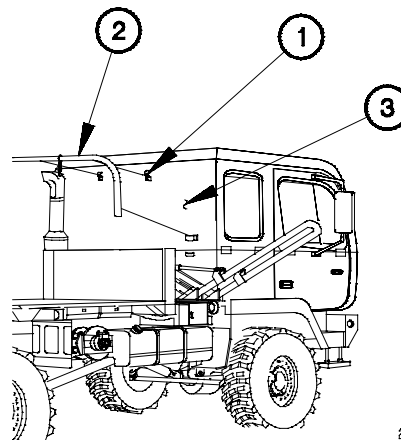
(3)

a. Spare Tire Stowage (Vehicles Not Equipped With Machine Gun Ring).

NOTE

Steps (1) through (24) require the aid of an assistant.

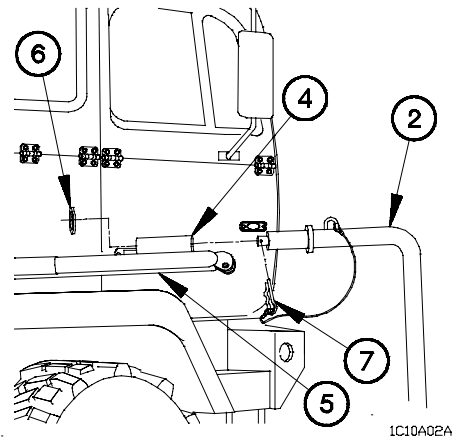
- (1) Unlatch three clamps (1) and remove davit (2) from rear panel (3).



2C10A01B

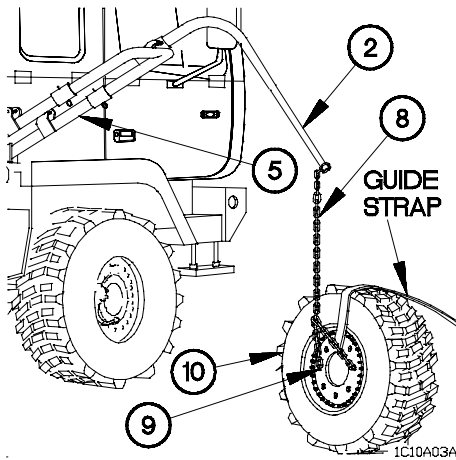
3-10. M1081 AIR DROP PREPARATION (CONT)

- (2) Install davit (2) in sleeve (4) of spare tire retainer lift arm (5).
- (3) Install safety washer (6) and lynch pin (7) in bottom of davit (2).



WARNING

Tire weighs approximately 350 lbs (159 kgs). Use extreme care when handling tire. Failure to comply may result in injury to personnel.

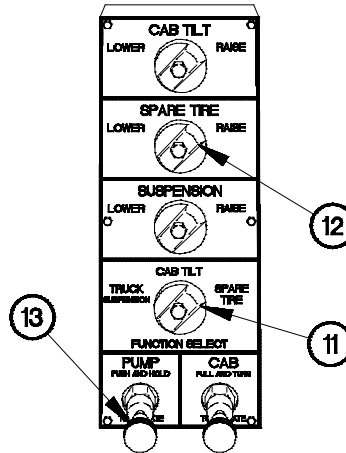


- (4) Disconnect chain (8) from spare tire retainer lift arm (5).
- (5) Install chain (8) through two wheel stud holes (9) then back to itself.
- (6) Connect other end of chain (8) to davit (2).
- (7) Attach guide strap to spare tire (10).

WARNING

Manifold operator must stand near hydraulic manifold and observe spare tire. Guide person must stand to the right front of vehicle, well clear of spare tire. Failure to comply may result in serious injury or death to personnel.

- (8) Turn FUNCTION SELECT knob (11) to SPARE TIRE position.
- (9) Turn SPARE TIRE knob (12) to RAISE position.

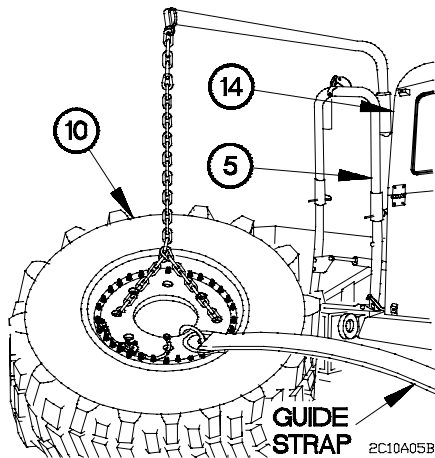


2C10A04B

NOTE

Use back-up hydraulic pump (para 2-41) if pressing PUMP knob does not accomplish step (10).

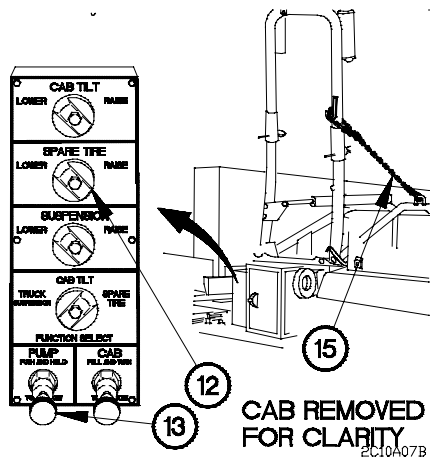
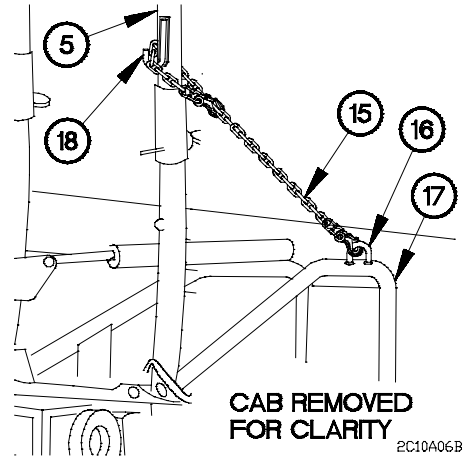
- (10) Press and hold PUMP knob (13).



- (11) Raise spare tire (10) until spare tire retainer lift arm (5) is aligned with right corner of cab (14).

3-10. M1081 AIR DROP PREPARATION (CONT)

- (12) Attach chain (15) to hook (16) on spare tire retainer (17).
- (13) Wrap other end of chain (15) around spare tire retainer lift arm (5) above hook (18) and hook chain back to itself.



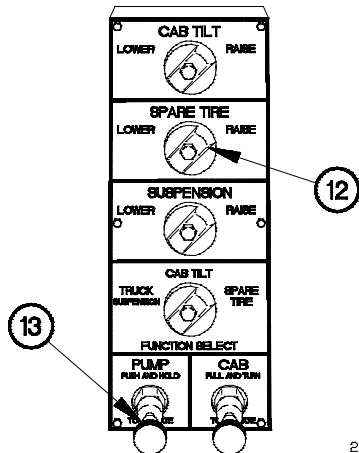
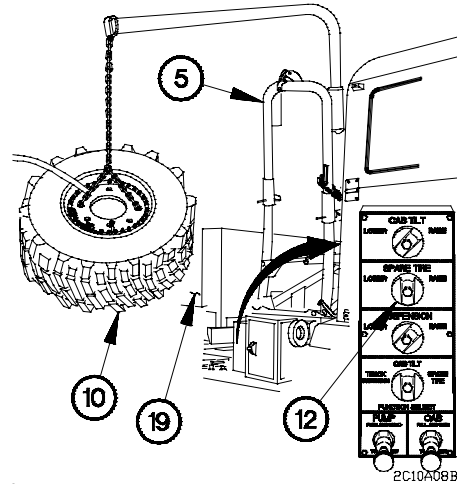
- (14) Turn SPARE TIRE knob (12) to LOWER position.

NOTE

Use back-up hydraulic pump (para 2-41) if pressing PUMP knob does not accomplish step (15).

- (15) Press and hold PUMP knob (13) until tension is on chain (15).

- (16) Turn SPARE TIRE knob (12) mid-way between RAISE and LOWER to lock spare tire retainer lift arm (5) in place.
- (17) Swing spare tire (10) over cargo bed (19).



- (18) Turn SPARE TIRE knob (12) to RAISE position.

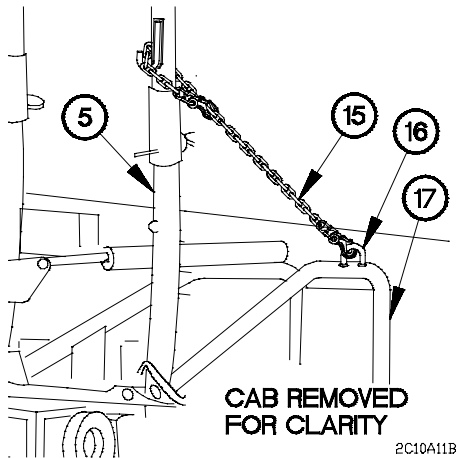
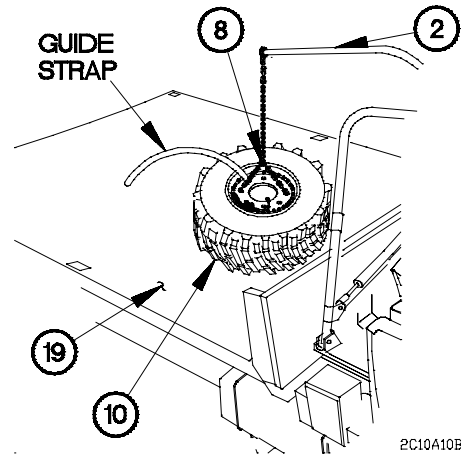
NOTE

Use back-up hydraulic pump (para 2-41) if pressing PUMP knob does not accomplish step (19).

- (19) Press and hold PUMP knob (13).

3-10. M1081 AIR DROP PREPARATION (CONT)

- (20) Position spare tire (10) in the front center of cargo bed (19).
- (21) Remove guide strap from spare tire (10).
- (22) Disconnect chain (8) from davit (2).
- (23) Disconnect chain (8) from spare tire (10).



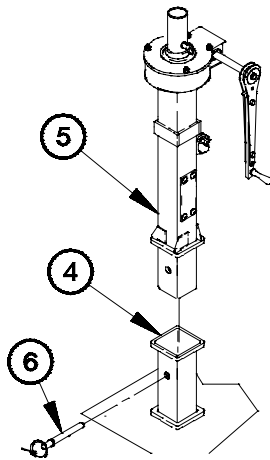
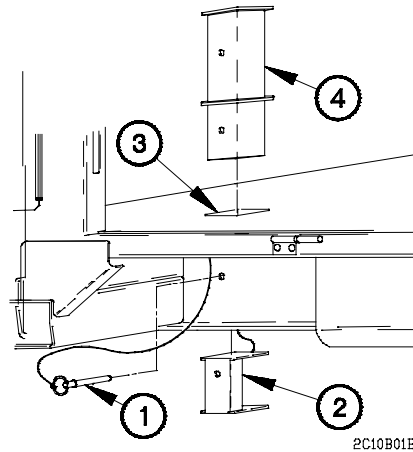
- (24) Disconnect chain (15) from hook (16) on spare tire retainer (17).
- (25) Disconnect other end of chain (15) from spare tire retainer lift arm (5).

b. Spare Tire Stowage (Vehicles Equipped With Machine Gun Ring).

NOTE

LMHC extension kit is installed in left front crane pocket.

- (1) Remove pin (1) and plug (2) from crane pocket (3).
- (2) Install crane extension (4) in crane pocket (3) with plug (2) and quick release pin (1).



WARNING

Mast weighs approximately 100 lbs (45 kgs). The aid of an assistant is required to install mast on crane extension. Failure to comply may result in injury to personnel or damage to equipment.

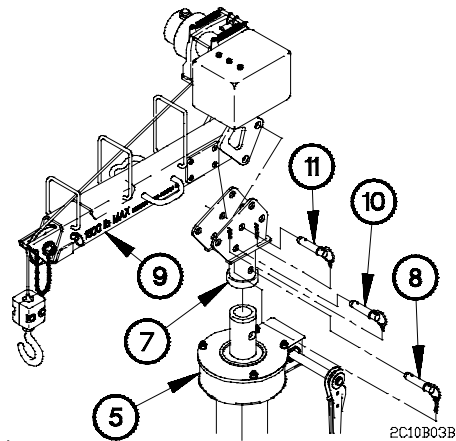
- (3) Install mast (5) in crane extension (4) with quick release pin (6).

3-10. M1081 AIR DROP PREPARATION (CONT)

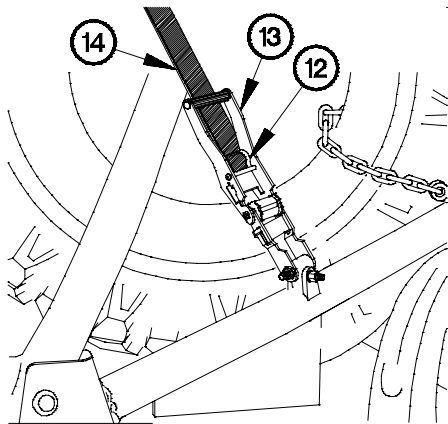
- (4) Position turret (7) on mast (5).
- (5) Install quick release pin (8) in turret (7).

WARNING

Light Material Handling Crane (LMHC) boom and winch weighs approximately 110 lbs (50 kgs). The aid of an assistant is required to install LMHC boom and winch. Failure to comply may result in injury to personnel or damage to equipment.



- (6) Position LMHC boom (9) on turret (7).
- (7) Install quick release pins (10 and 11) in turret (7).
- (8) Set LMHC boom (9) to 25-degrees (para 2-24f).
- (9) Extend LMHC boom (9) fully (para 2-24g).
- (10) Connect remote control and power cable connectors (para 2-24d).

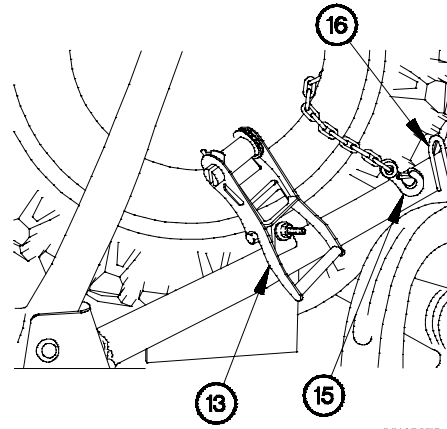


- (11) Raise cab (para 2-22a).
- (12) Release latch (12) on ratchet (13).
- (13) Lift ratchet (13) and release strap (14).
- (14) Remove strap (14) from ratchet (13).

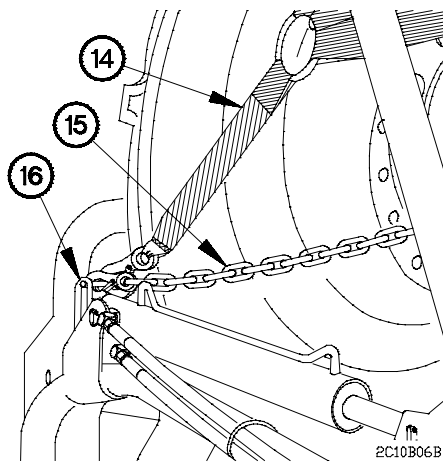
- (15) Disconnect safety chain (15) from spare tire retainer (16).

CAUTION

Ratchet must be in the close position before cab is lowered. Failure to comply may result in damage to equipment.

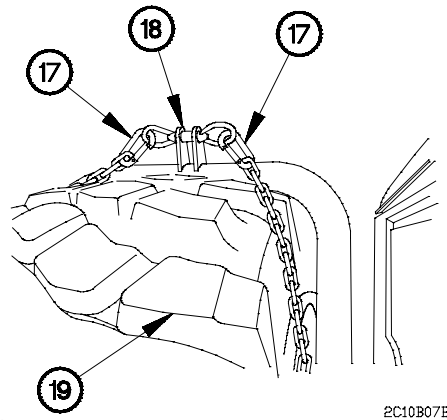


- (16) Place ratchet (13) in close position.



- (17) Remove strap (14) and safety chain (15) from spare tire retainer (16).
 (18) Lower cab (para 2-22b).

- (19) Disconnect both ends of chain (17) from spare tire retainer lift arm (18).
 (20) Pull chain (17) through spare tire (19).



3-10. M1081 AIR DROP PREPARATION (CONT)

- (21) Turn FUNCTION SELECT knob (20) to SPARE TIRE position.
- (22) Turn SPARE TIRE knob (21) to LOWER position.

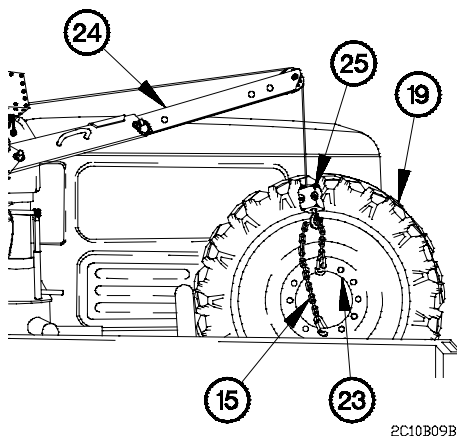
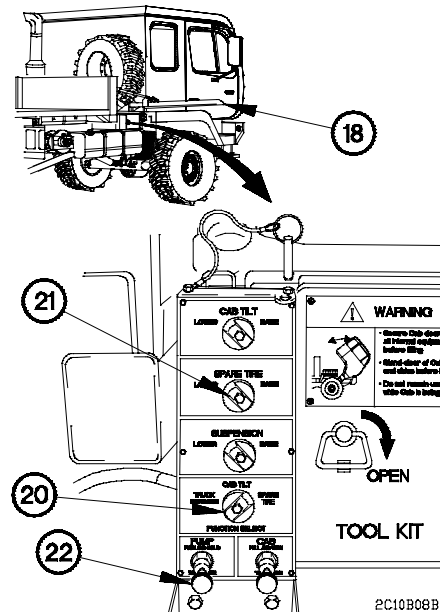
WARNING

Ensure spare tire retainer lift arm doesn't grab spare tire while being lowered. Failure to comply may result in injury to personnel or damage to equipment.

NOTE

Use back-up hydraulic pump (para 2-41) if pressing PUMP knob does not accomplish step (23).

- (23) Press and hold PUMP knob (22) until spare tire retainer lift arm (18) is lowered.



- (24) Attach safety chain (15) to spare tire wheel hub (23) as shown.
- (25) Position LMHC (24) over spare tire (19).
- (26) Connect safety chain (15) to hook (25) on LMHC (24).

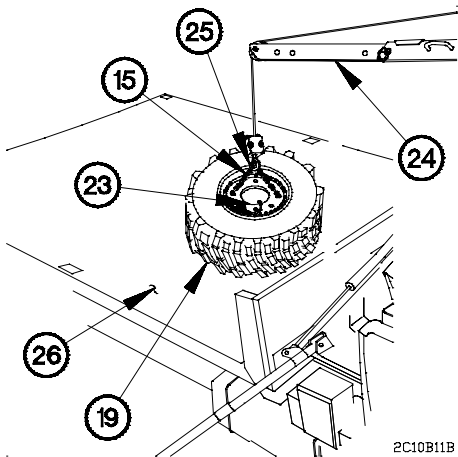
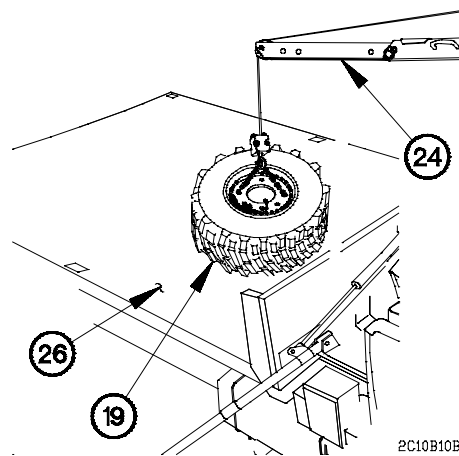
WARNING

Tire weighs approximately 350 lbs (159 kgs). Use extreme care when handling tire. Failure to comply may result in injury to personnel.

NOTE

Steps (27) through (29) require the aid of an assistant.

- (27) Raise spare tire (19) with LMHC (24).
- (28) Position spare tire (19) over center of cargo bed (26).
- (29) Lower spare tire (19) on cargo bed (26).



- (30) Disconnect safety chain (15) from hook (25) on LMHC (24).
- (31) Remove safety chain (15) from spare tire wheel hub (23).

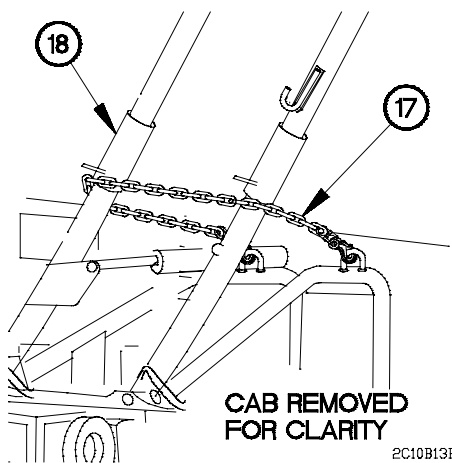
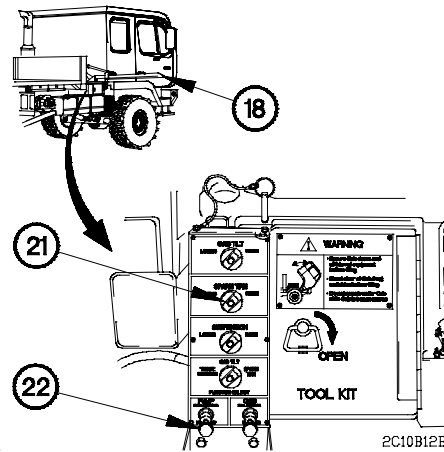
NOTE

Step (32) requires the aid of an assistant.

- (32) Position spare tire (19) in front center of cargo bed (26).

3-10. M1081 AIR DROP PREPARATION (CONT)

- (33) Turn SPARE TIRE knob (21) to RAISE position.
- (34) Press and hold PUMP knob (22) until spare tire retainer lift arm (18) is raised.



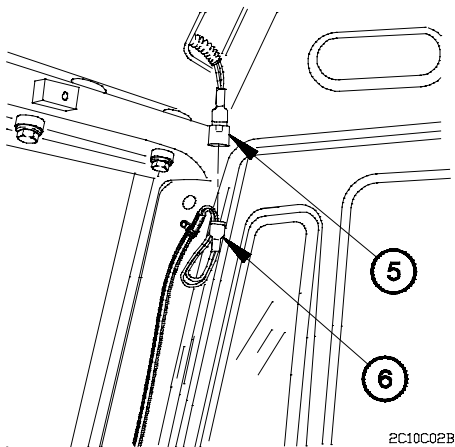
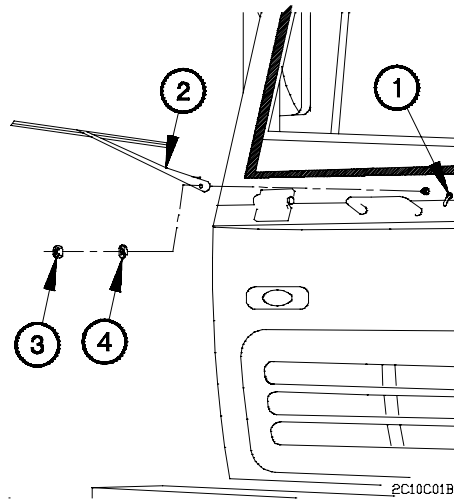
- (35) Attach safety chain (17) to spare tire retainer lift arm (18).

c. Cab Preparation.

NOTE

- Stow all loose items before preparing cab.
- Both windshield wiper arms are removed the same way. Right side shown.

- (1) Remove windshield washer tube (1) from windshield wiper arm (2).
- (2) Remove nut (3), lockwasher (4), and windshield wiper arm (2) from vehicle.
- (3) Stow two wiper arms (2), lockwashers (4), and nuts (3) in tool box.



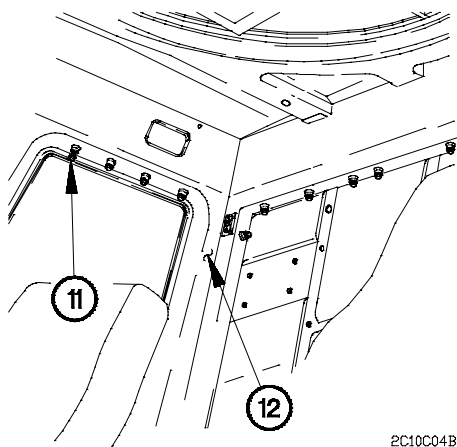
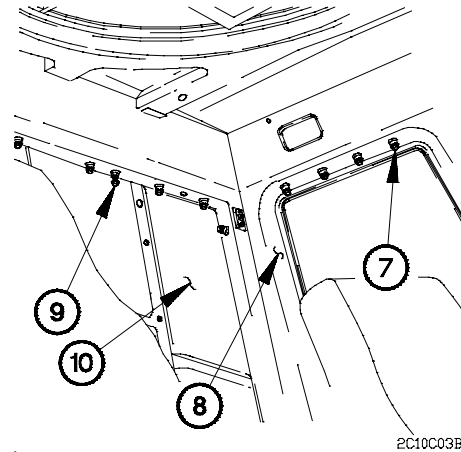
- (4) Disconnect connector P3 (5) from connector J3 (6).

3-10. M1081 AIR DROP PREPARATION (CONT)

NOTE

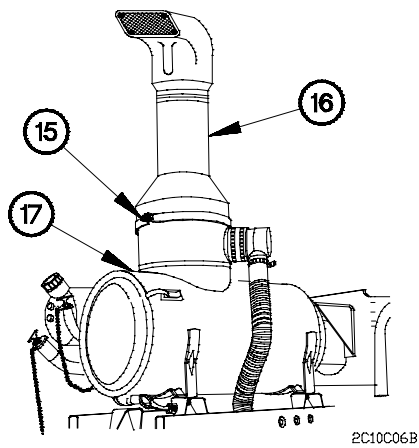
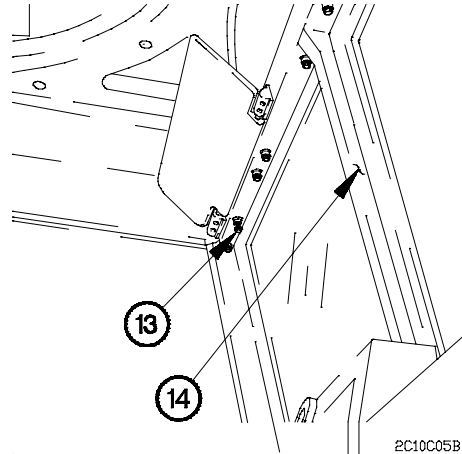
It is necessary to pull down on captive bolt, after loosening, to lock it in place.

- (5) Loosen four captive bolts (7) from left side panel (8).
- (6) Pull down on four captive bolts (7) to lock in place.
- (7) Loosen ten captive bolts (9) from rear panel (10).
- (8) Pull down on ten captive bolts (9) to lock in place.



- (9) Loosen four captive bolts (11) from right side panel (12).
- (10) Pull down on four captive bolts (11) to lock in place.

- (11) Loosen ten captive bolts (13) from windshield (14).
- (12) Pull down on ten captive bolts (13) to lock in place.

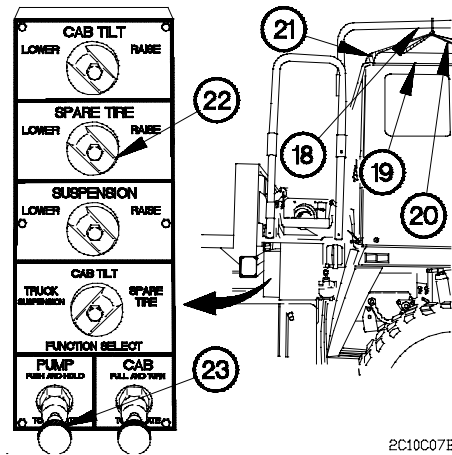


- (13) Loosen clamp (15) and remove air intake adapter (16) from intake air cleaner housing (17).

3-10. M1081 AIR DROP PREPARATION (CONT)

NOTE

- Steps (14) through (25) require the aid of an assistant.
 - Perform steps (14) through (25) on cab roofs not equipped with machine gun ring.
- (14) Position davit (18) over center of cab roof (19).
 - (15) Install lifting strap (20) on four brackets (21).
 - (16) Attach lifting strap (20) to davit (18).
 - (17) Turn SPARE TIRE knob (22) to LOWER position.



2C10C07B

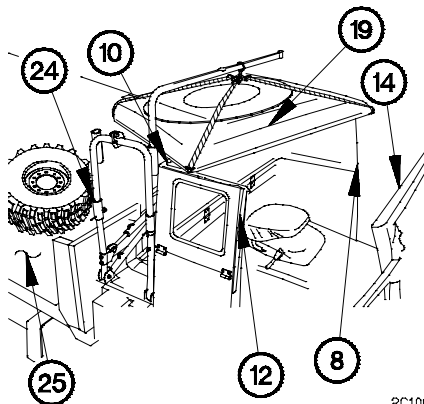
NOTE

Use back-up hydraulic pump (para 2-41) if pressing PUMP knob does not accomplish step (18).

- (18) Press and hold PUMP knob (23).

NOTE

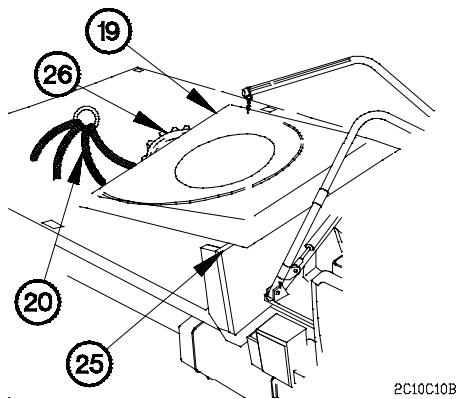
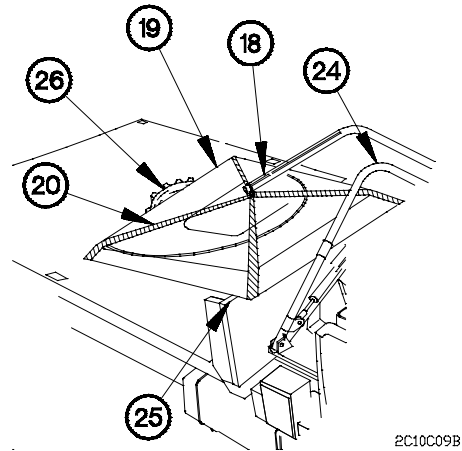
It may be necessary to push up on cab roof, from inside cab, to help loosen cab roof from cab.



2C10C08B

- (19) Raise spare tire retainer lift arm (24) until cab roof (19) is clear of windshield (14), right side panel (12), left side panel (8), and rear panel (10).
- (20) Swing cab roof (19) around so cab roof is over cargo bed (25).

- (21) Lower spare tire retainer lift arm (24) until cab roof (19) sits on front side of cargo bed (25) and spare tire (26).
- (22) Remove lifting strap (20) from davit (18).



WARNING

Cab roof weighs approximately 110 lbs (50 kgs). Use care when handling cab roof. Failure to comply may result in injury to personnel or damage to equipment.

- (23) Lift cab roof (19) from front side of cargo bed (25) and edge of spare tire (26).
- (24) Position cab roof (19) over center of spare tire (26).
- (25) Remove lifting strap (20) from cab roof (19).

NOTE

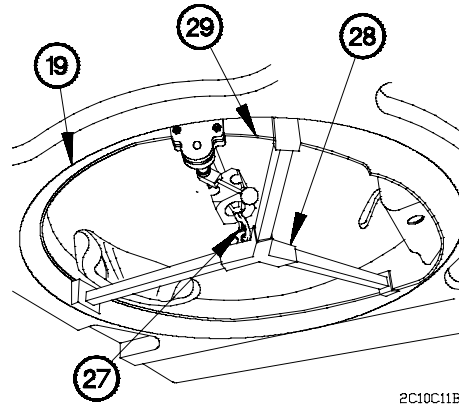
Perform steps (26) through (49) on cab roofs equipped with machine gun ring.

- (26) Position LMHC hook (27) over center of cab roof (19).
- (27) Install y-adapter (28) on machine gun ring (29).

CAUTION

Hook must be installed on hole closest to the front of cab roof. Rotate machine gun ring until hole is facing towards front of vehicle. Failure to comply may result in damage to equipment.

- (28) Install LMHC hook (27) to y-adapter (28).



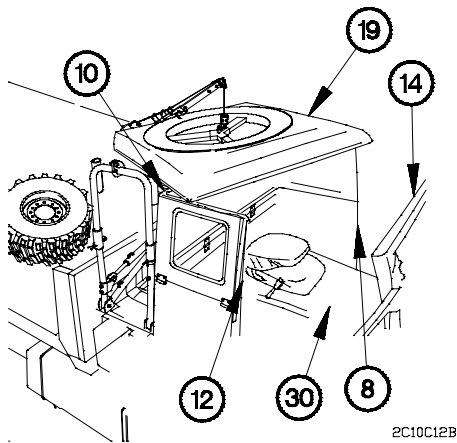
2C10C11B

WARNING

Cab roof and machine gun ring weigh approximately 500 lbs (227 kgs). The aid of two assistants is required to remove the cab roof and machine gun ring. Failure to comply may result in injury to personnel or damage to equipment.

NOTE

It may be necessary to push up on cab roof, from inside cab, to help loosen cab roof from cab.

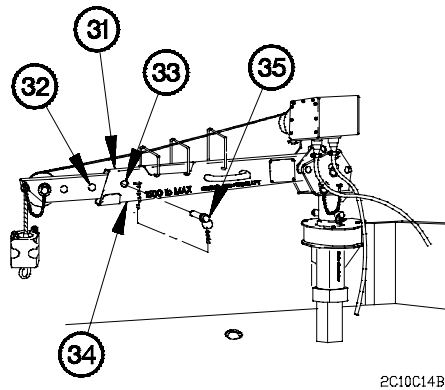
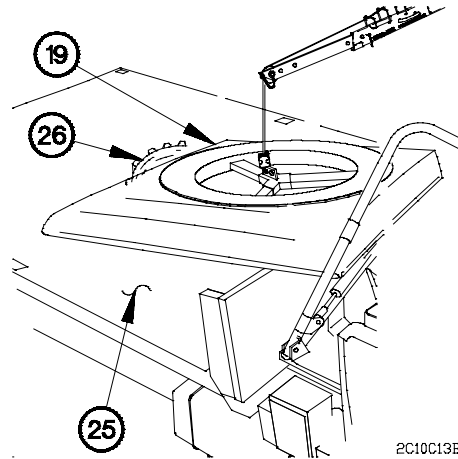


2C10C12B

- (29) Lift cab roof (19) from cab (30) until cab roof is clear of windshield (14), right side panel (12), left side panel (8), and rear panel (10).

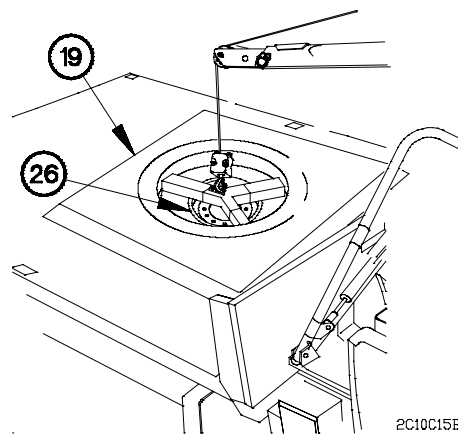
3-10. M1081 AIR DROP PREPARATION (CONT)

- (30) Swing cab roof (19) around so cab roof is over cargo bed (25).
- (31) Lower cab roof (19) until cab roof sits on cargo bed (25) and spare tire (26).

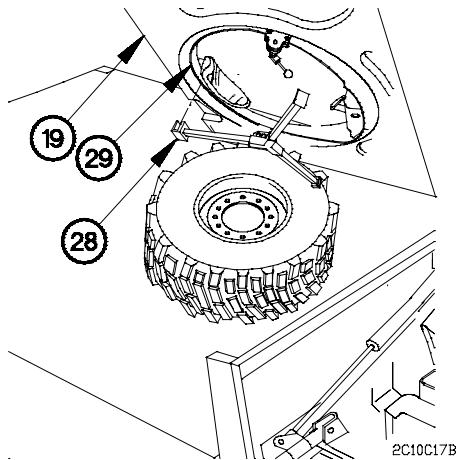
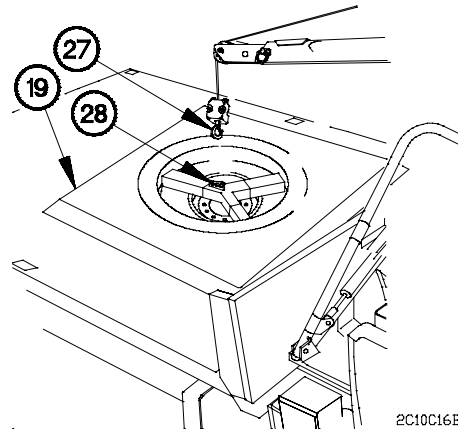


- (32) Retract LMHC boom (31) until the second hole (32) on the LMHC boom is aligned with the hole (33) on the boom (34).
- (33) Install quick release pin (35) in hole (33).

- (34) Lift cab roof (19) over center of spare tire (26).
- (35) Position cab roof (19) over center of spare tire (26).
- (36) Lower cab roof (19) on spare tire (26).



- (37) Remove LMHC hook (27) from y-adapter (28).
- (38) Position LMHC hook (27) away from cab roof (19).



NOTE

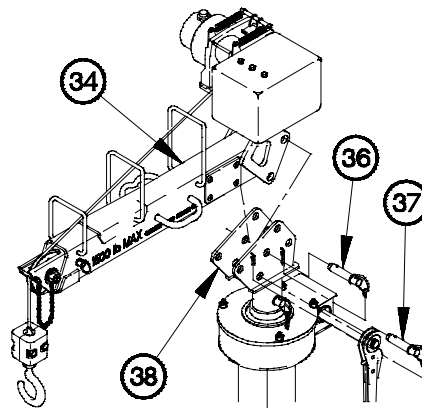
- Steps (39) and (40) require the aid of two assistants.
 - Lift edges of cab roof until y-adapter can be removed.
- (39) Lift front and rear of cab roof (19).
 - (40) Remove y-adapter (28) from machine gun ring (29).

3-10. M1081 AIR DROP PREPARATION (CONT)

- (41) Disconnect remote control and power cable connectors (para 2-24d).
- (42) Lower boom (34) to 0-degrees (para 2-24f).
- (43) Remove quick release pins (36 and 37) from turret (38).

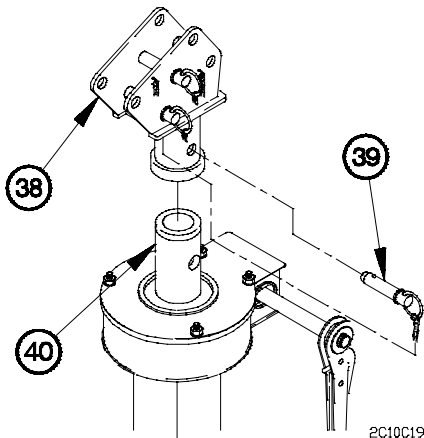
WARNING

LMHC boom and winch weighs approximately 100 lbs (45 kgs). The aid of an assistant is required to remove LMHC boom and winch. Failure to comply may result in injury to personnel or damage to equipment.



2C10C18B

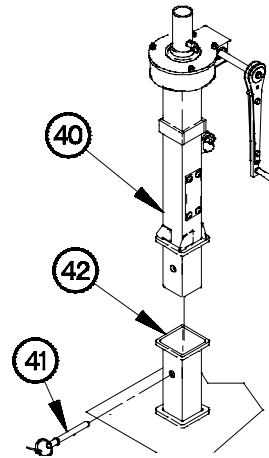
- (44) Remove boom (34) from turret (38).



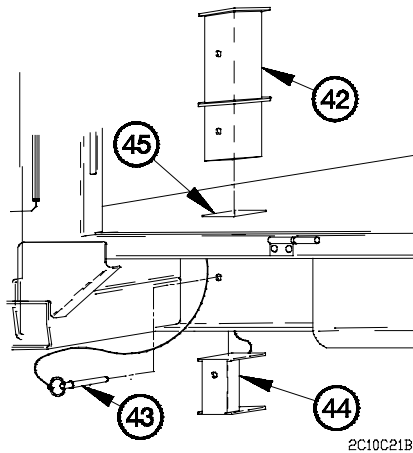
2C10C19B

- (45) Remove quick release pin (39) from turret (38).
- (46) Remove turret (38) from mast (40).

- (47) Remove quick release pin (41) and mast (40) from LMHC extension (42).



2C10C20B



2C10C21B

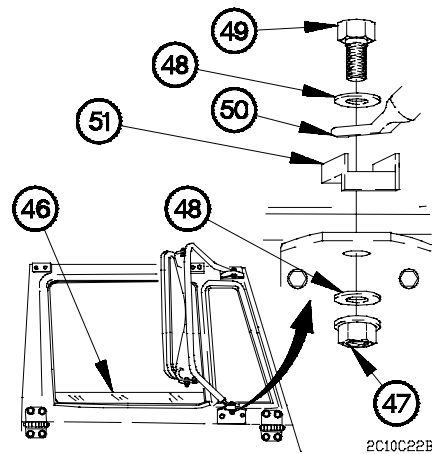
- (48) Remove quick release pin (43), plug (44), and LMHC extension (42) from crane pocket (45).

- (49) Install plug (44) in crane pocket (45) with quick release pin (43).

NOTE

Left and right side mirrors are folded the same way. Right side shown.

- (50) Roll window (46) completely down.
- (51) Remove nut (47), two washers (48), and screw (49) from mirror support (50).
- (52) Remove clip (51) from mirror support (50).



2C10C22B

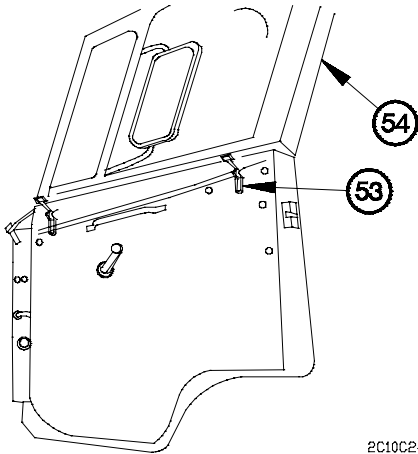
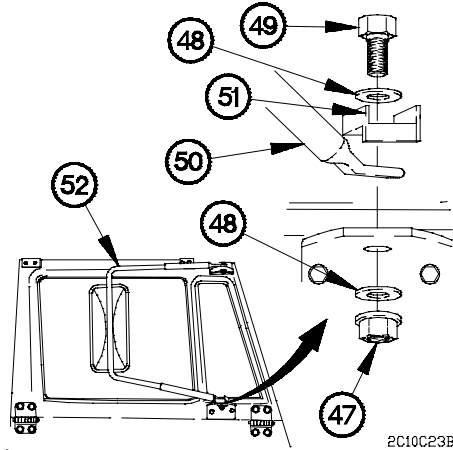
3-10. M1081 AIR DROP PREPARATION (CONT)

- (53) Fold mirror (52) in door window opening.

NOTE

Stow clip in position shown on mirror support.

- (54) Install screw (49), two washers (48), clip (51), and nut (47) on mirror support (50).



NOTE

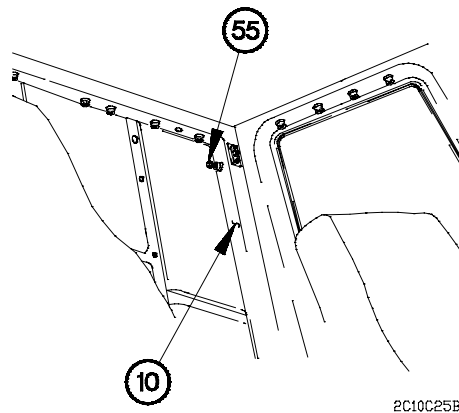
Left and right side doors are lowered the same way. Right side shown.

- (55) Release door latches (53) on doors (54) and lower top half of door out and lock in place.

NOTE

Left and right side rear panels are lowered the same way. Left side shown.

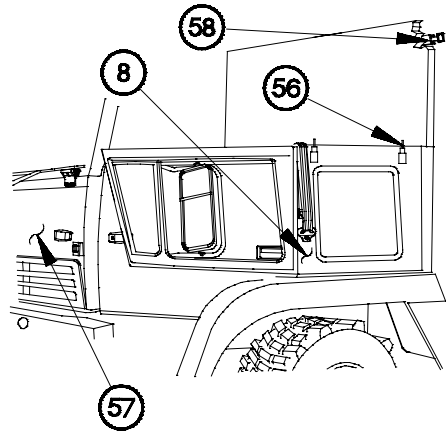
- (56) Loosen captive bolt (55) from left side of rear panel (10).



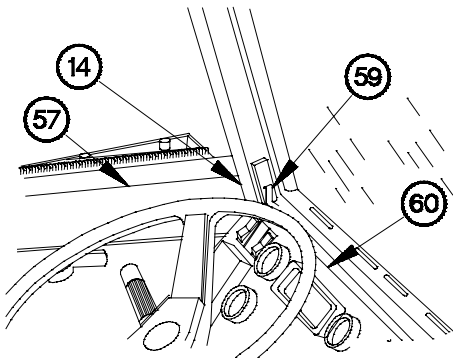
NOTE

Left and right side panels are released the same way. Left side shown.

- (57) Release three side panel latches (56) on side panel (8) on inside of cab (57).
- (58) Release two side panel latches (58) on outside of cab (57).
- (59) Lower top half of side panel (8) outward and lock in place.



2C10C26B



2C10C27B

- (60) Release two windshield latches (59) above dashboard (60) on inside of cab (57).

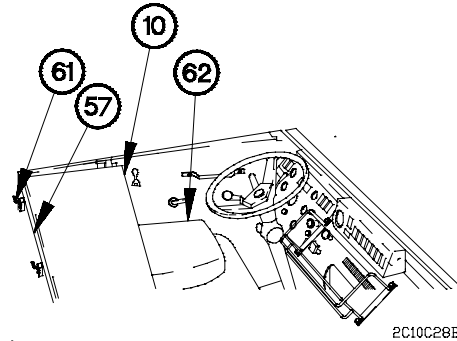
CAUTION

Use care when working around windshield and door glass. Failure to comply may result in damage to equipment.

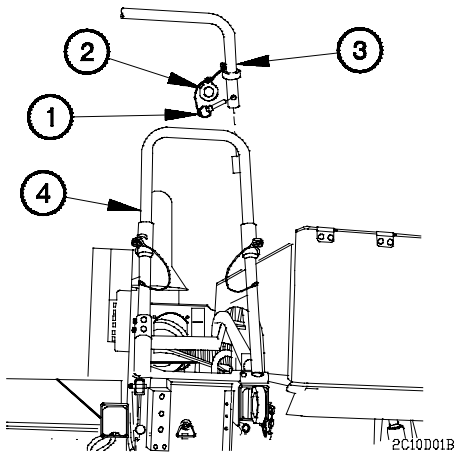
- (61) Lower windshield (14) outward and lock in place.

3-10. M1081 AIR DROP PREPARATION (CONT)

- (62) Release five rear panel latches (61) on outside of cab (57).
- (63) Fold down three seats (62).
- (64) Lower rear panel (10) forward in cab (57).



d. Spare Tire Retainer and Davit Preparation.



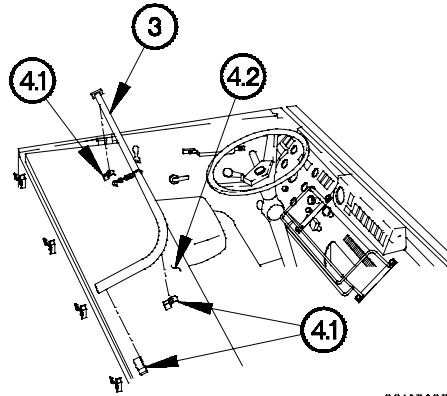
NOTE

- Steps (1) through (6) require the aid of an assistant.
 - Perform steps (1) through (3) on cab roofs not equipped with machine gun ring.
- (1) Disconnect safety pin (1) and safety washer (2) from davit (3).
 - (2) Remove davit (3) from spare tire retainer lift arm (4).
 - (3) Connect safety washer (2) and safety pin (1) on davit (3).

NOTE

Perform step (3.1) on cab roofs equipped with machine gun ring.

- (3.1) Unlatch three clamps (4.1) and remove davit (3) from rear panel (4.2).

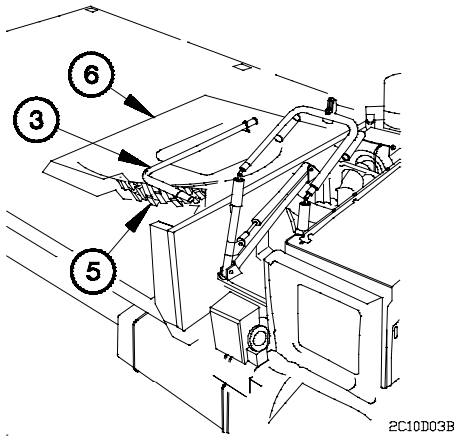


2C10D02B

NOTE

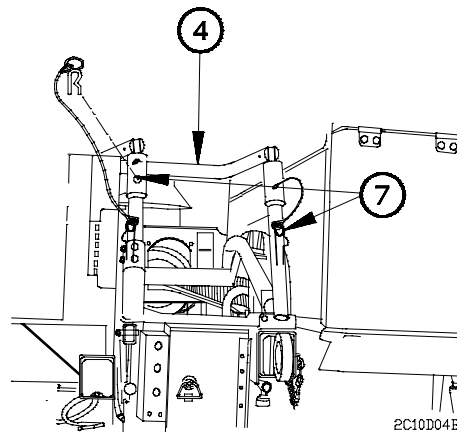
Air drop personnel will secure spare tire, cab top, and davit with rigging prior to air drop.

- (4) Stow davit (3) with spare tire (5) and cab roof (6).



2C10D03B

- (5) Remove two safety pins (7) from spare tire retainer lift arm (4).
- (6) Lower spare tire retainer lift arm (4) to stowage position and secure to vehicle.



2C10D04B

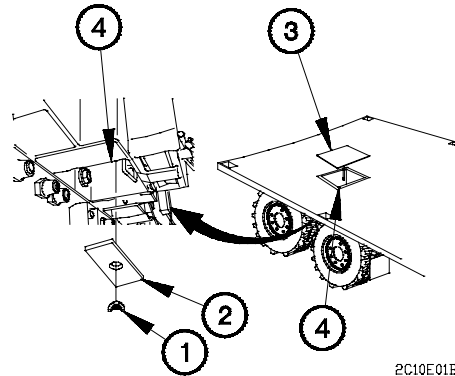
3-10. M1081 AIR DROP PREPARATION (CONT)

e. Slide Assembly Installation.

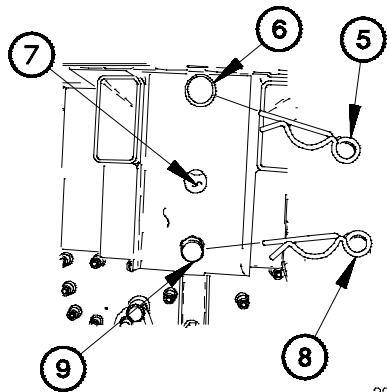
NOTE

Steps (1) through (11) require the aid of an assistant.

- (1) Remove wing nut (1) and retaining bar (2) from cover plate assembly (3).
- (2) Remove cover plate assembly (3) from slide assembly receptacle (4).
- (3) Assemble retaining bar (2) and wing nut (1) on threaded rod of cover plate assembly (3). Stow in tool box.



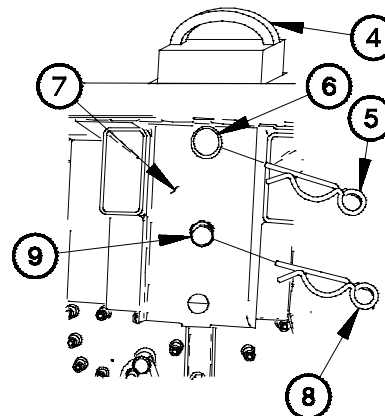
2C10E01B



2C10E02B

- (4) Remove safety pin (5) from large pin (6) of slide assembly (7).
- (5) Remove safety pin (8) from small pin (9) of slide assembly (7).
- (6) Remove small pin (9) from slide assembly (7).
- (7) Remove large pin (6) while holding slide assembly (7).

- (8) Align small hole of slide assembly (7) with middle hole of slide assembly receptacle (4).
- (9) Install small pin (9) in slide assembly (7) and slide assembly receptacle (4).
- (10) Install large pin (6) in slide assembly (7) and slide assembly receptacle (4).
- (11) Install two safety pins (5 and 8) in pins (6 and 9).



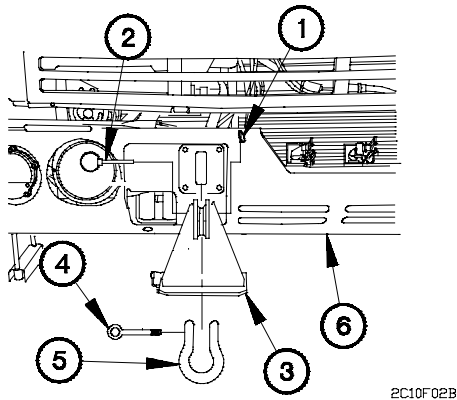
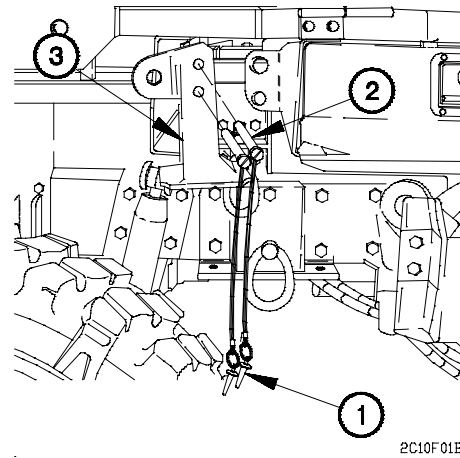
2C10E03B

f. Load Spreader Installation.

NOTE

- A load spreader is mounted on both sides of vehicle. Left side shown.
- Steps (1) through (8) require the aid of an assistant.

- (1) Remove two safety pins (1) from pins (2) on vehicle.
- (2) Remove two pins (2) and front load spreader (3) from vehicle.



- (3) Remove pin (4) and shackle (5) from front bumper (6).
- (4) Install front load spreader (3) on front bumper (6) with two pins (2).
- (5) Install two safety pins (1) in pins (2).
- (6) Mount shackle (5) on front load spreader (3).
- (7) Install pin (4) on front load spreader (3) and shackle (5) finger tight.

g. Follow-On Maintenance.

Remove wheel chocks (para 2-21h).

End of Task.

3-11. M1081 AIR DROP RECOVERY OPERATIONS

This task covers:

- a. Cab Recovery
- b. Spare Tire Recovery (Vehicles Equipped with Machine Gun Ring).
- c. Spare Tire Recovery (Vehicles Not Equipped with Machine Gun Ring).
- d. Slide Assembly Recovery
- e. Load Spreader Recovery
- f. Follow-On Maintenance

INITIAL SETUP

Equipment Conditions

Vehicle parked on level ground.
 Engine shut down (para 2-21f).
 Wheels chocked (para 2-21h).

Tools and Special Tools

Wrench Assembly, Speedhandle (Item 6 (COEI), Appendix B)
 Wrench, Adjustable, 8 in. (Item 16, Appendix B)
 Strap Assembly (Item 5 (COEI), Appendix B)
 Sling Assembly, Air Drop Roof (Item 4 (COEI), Appendix B)

Tools and Special Tools (Cont)

Crane, Light Material Handling, Kit 1500 lb Capacity (Appendix C) (Vehicles equipped with machine gun ring)
 Crane Adapter Kit (Appendix C) (Vehicles equipped with machine gun ring)

References

FM 10-526

Personnel Required

(3)

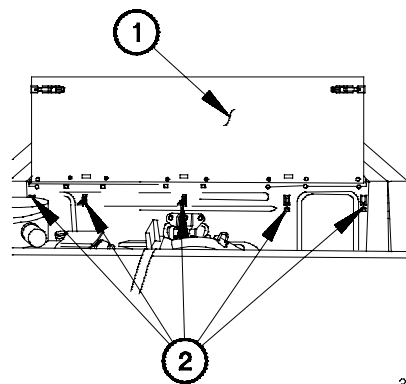
a. Cab Recovery.



Vehicle must not be operated until rear panel and side panels are raised and properly secured. Failure to comply may result in serious injury or death to personnel or damage to equipment.

NOTE

Steps (1) through (56) require the aid of an assistant.



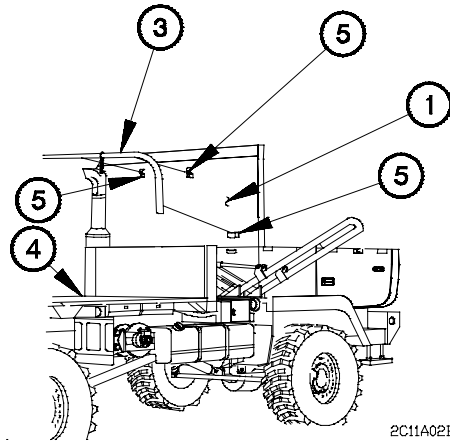
2C11A01B

- (1) Raise rear panel (1) and fasten five panel latches (2).

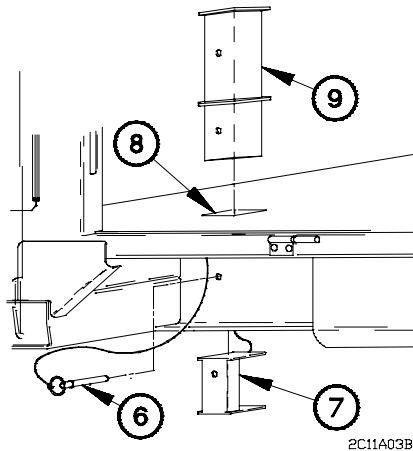
NOTE

Perform steps (2) through (13) on vehicles equipped with machine gun ring.

- (2) Remove davit (3) from cargo bed (4).
- (3) Stow davit (3) on back of rear panel (1) and close three clamps (5).



2C11A02B



2C11A03B

NOTE

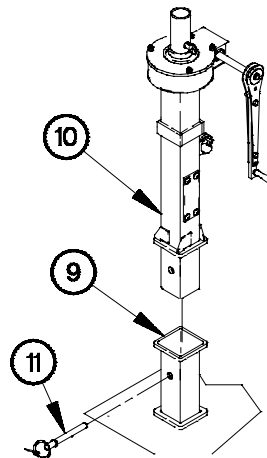
LMHC extension kit is installed in left front crane pocket.

- (4) Remove quick release pin (6) and plug (7) from crane pocket (8).
- (5) Install crane extension (9) in crane pocket (8) with plug (7) and quick release pin (6).

WARNING

Mast weighs approximately 100 lbs (45 kgs). The aid of an assistant is required to install mast on crane extension. Failure to comply may result in injury to personnel or damage to equipment.

- (6) Install mast (10) in crane extension (9) with quick release pin (11).



2C11A04B

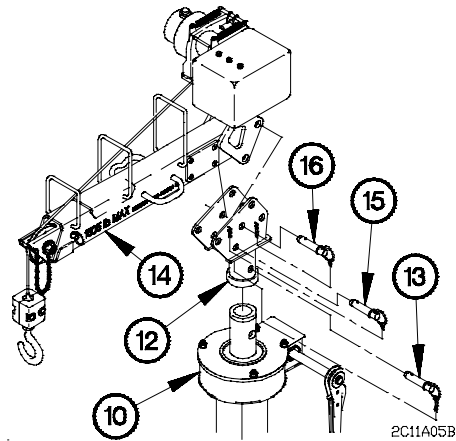
3-11. M1081 AIR DROP RECOVERY OPERATIONS (CONT)

- (7) Position turret (12) on mast (10).
- (8) Install quick release pin (13) in turret (12).

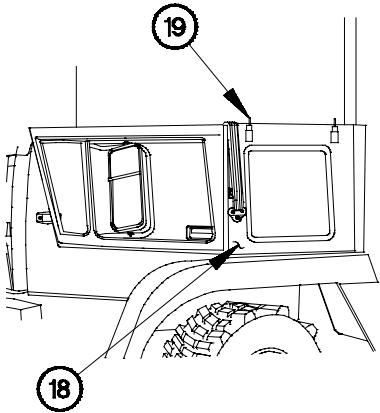
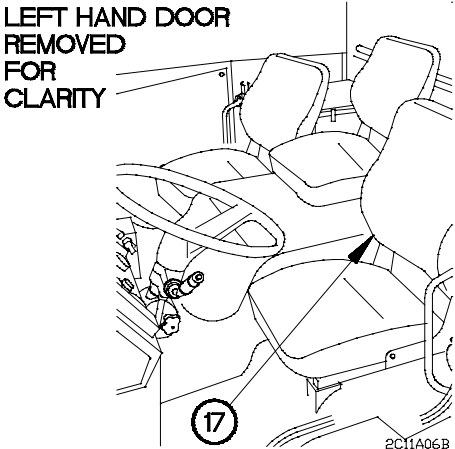
WARNING

Light **M**aterial **H**andling **C**rane (LMHC) boom and winch weighs approximately 100 lbs (50 kgs). The aid of an assistant is required to install LMHC boom and winch.

- (9) Position LMHC boom (14) on turret (12).
- (10) Install quick release pins (15 and 16) in turret (12).
- (11) Set LMHC boom (14) to 25-degrees (para 2-24f).
- (12) Extend LMHC boom (14) fully (para 2-24g).
- (13) Connect remote control and power cable connectors (para 2-24d).



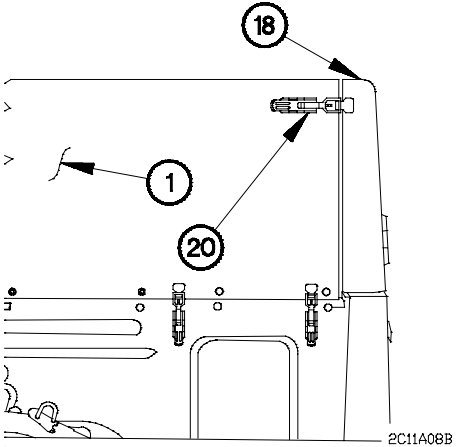
(14) Raise three seat backs (17).



(14) Raise top half of two side panels (18) and fasten four side panel latches (19) on inside of vehicle.

2C11A07B

(16) Fasten two latches (20) to side panels (18) and rear panel (1) on outside of vehicle.



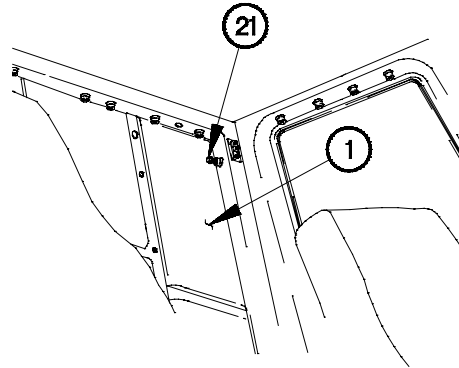
2C11A08B

3-11. M1081 AIR DROP RECOVERY OPERATIONS (CONT)

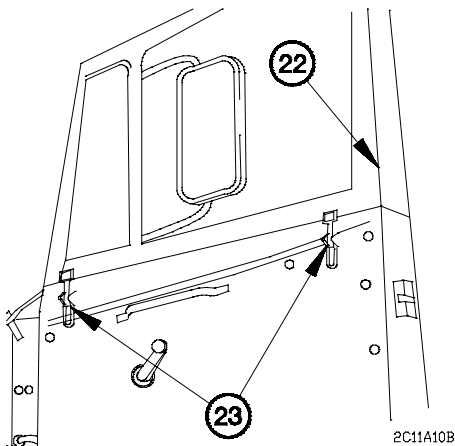
NOTE

Left and right side captive bolts attach the same way.
Left side shown.

- (17) Install captive bolt (21) in rear panel (1).



2C11A09B



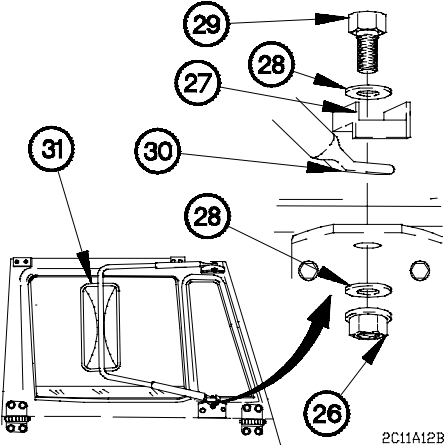
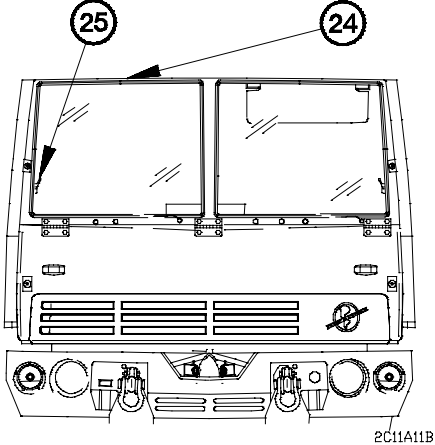
2C11A10B

NOTE

Right and left doors are raised the same way. Right side shown.

- (18) Raise top half of door (22) and fasten two latches (23).

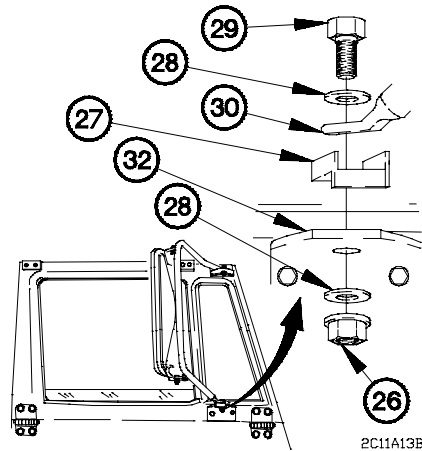
(19) Raise windshield (24) and fasten two windshield latches (25).



- (20) Remove nut (26), clip (27), two washers (28), and screw (29) from mirror support (30).
- (21) Unfold mirror (31).

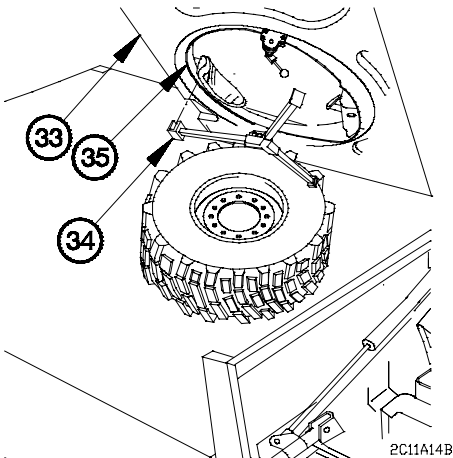
3-11. M1081 AIR DROP RECOVERY OPERATIONS (CONT)

- (22) Install clip (27) between mirror support (30) and bracket (32).
- (23) Install screw (31), two washers (28), and nut (26).



NOTE

- Perform steps (24) through (33) on cab roofs equipped with machine gun ring.
- Steps (24) and (25) require the aid of two assistants.
- Lift edges of cab roof until y-adapter can be installed.



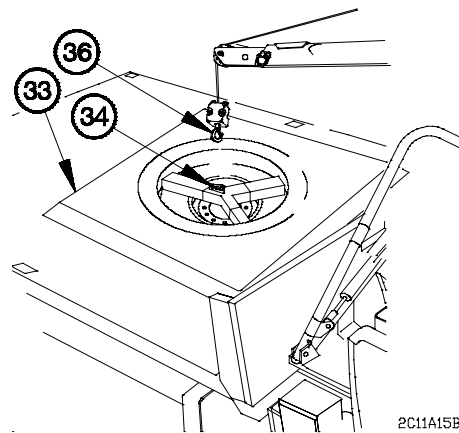
- (24) Lift front and rear of cab roof (33).
- (25) Install y-adapter (34) on machine gun ring (35).

- (26) Position LMHC hook (36) over cab roof (33).

CAUTION

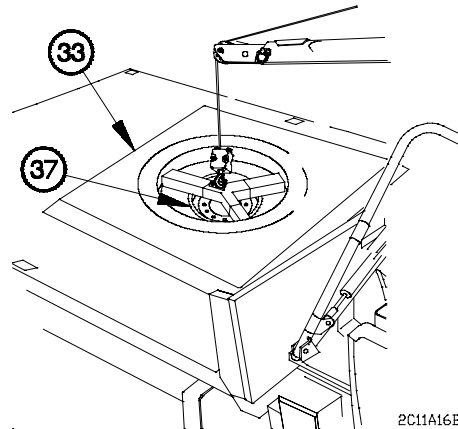
Hook must be installed on hole closest to the front of cab roof. Failure to comply may result in damage to equipment.

- (27) Install LMHC hook (36) to y-adapter (34).



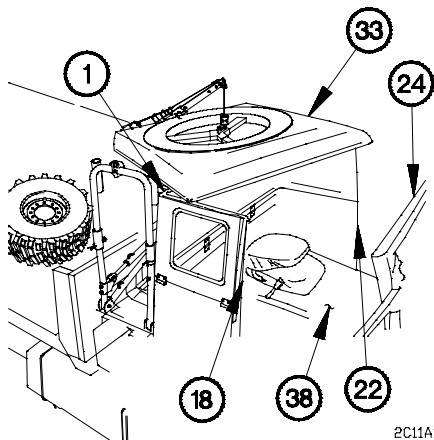
WARNING

- Use caution when raising cab roof. Cab roof may swing rearward upon first raising from spare tire. The aid of two assistants is required to control cab roof. Failure to comply may result in injury to personnel or damage to equipment.
- Cab roof and machine gun ring weigh approximately 500 lbs (227 kgs). The aid of two assistants is required to install cab roof and machine gun ring. Failure to comply may result in injury to personnel or damage to equipment.



2C11A16B

(28) Lift cab roof (33) from spare tire (37).

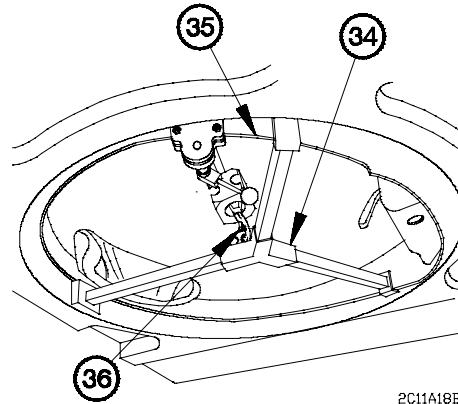


2C11A17B

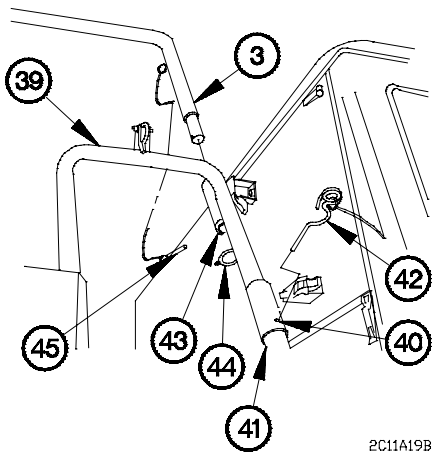
- (29) Swing cab roof (33) around so cab roof is over cab (38).
- (30) Align cab roof (33) over rear panel (1), side panel (18), doors (22), and windshield (24).
- (31) Lower cab roof (33).

3-11. M1081 AIR DROP RECOVERY OPERATIONS (CONT)

- (32) Remove y-adapter (34) from machine gun ring (35).
- (33) Remove y-adapter (34) from LMHC hook (36).



2C11A18B



2C11A19B

NOTE

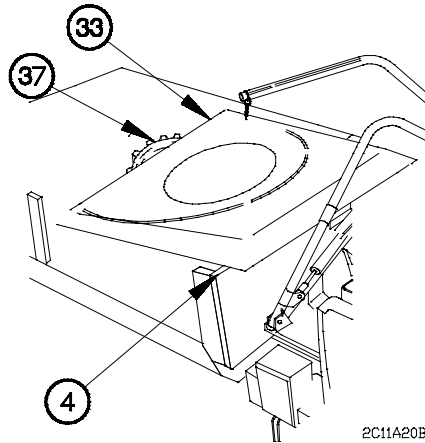
Perform steps (34) through (54) on cab roofs not equipped with machine gun ring.

- (34) Raise spare tire lift arm (39) and align hole in collar (40) with hole in spare tire retainer (41).
- (35) Install two safety pins (42) in spare tire lift arm (39).
- (36) Install davit (3) in sleeve (43) on spare tire lift arm (39).
- (37) Install safety washer (44) and safety pin (45) in bottom of davit (3).

WARNING

Cab roof weighs approximately 110 lbs (50 kgs). Use caution when handling cab roof. Failure to comply may result in injury to personnel or damage to equipment.

- (38) Lift cab roof (33) and lower on front side of cargo bed (4) and spare tire (37).

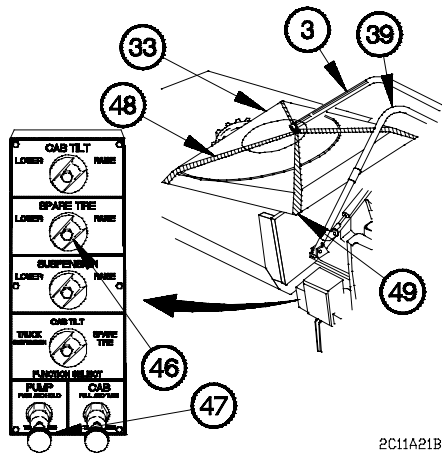


2C11A20B

- (39) Turn SPARE TIRE knob (46) to RAISE position.

NOTE

Use back-up hydraulic pump (para 2-41) if pressing PUMP knob does not accomplish step (40).



2C11A21B

- (40) Press and hold PUMP knob (47).
- (41) Raise spare tire lift arm (39) and davit (3) over center of cab roof (33).
- (42) Connect lifting strap (48) to four brackets (49) on cab roof (33).

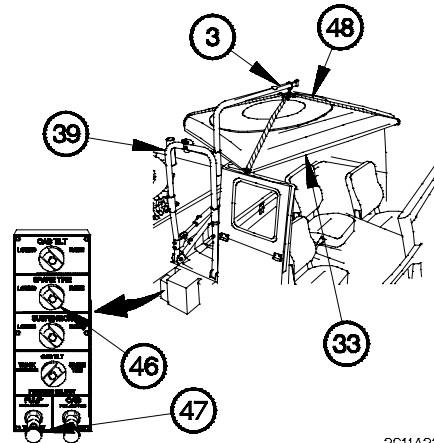
3-11. M1081 AIR DROP RECOVERY OPERATIONS (CONT)

- (43) Connect lifting strap (48) to davit (3).
- (44) Turn SPARE TIRE knob (46) to LOWER position.

NOTE

Use back-up hydraulic pump (para 2-41) if pressing PUMP knob does not accomplish step (45).

- (45) Press and hold PUMP knob (47).
- (46) Raise cab roof (33) until spare tire lift arm (39) is straight up and down.



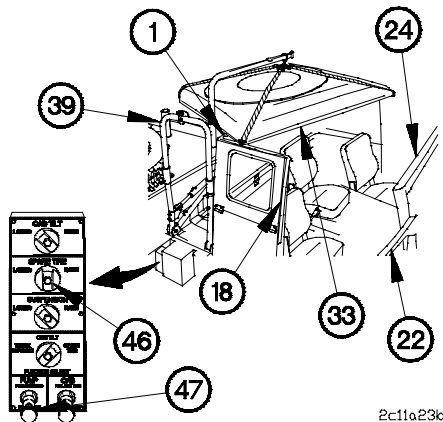
2C11A22B

- (47) Turn SPARE TIRE knob (46) mid-way between RAISE and LOWER position to lock spare tire lift arm (39) in place.

NOTE

Use back-up hydraulic pump (para 2-41) if pressing PUMP knob does not accomplish step (48).

- (48) Press and hold PUMP knob (47).
- (49) Align cab roof (33) over rear panel (1), side panel (18), doors (22), and windshield (24).



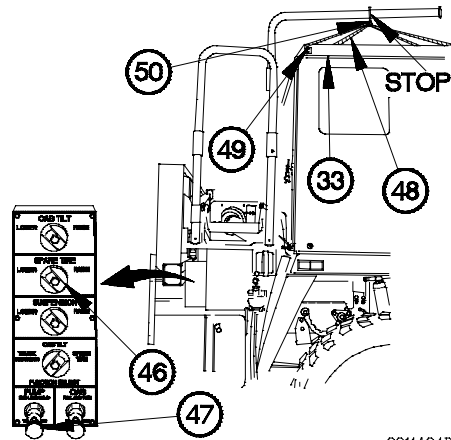
2c11a23b

- (50) Turn SPARE TIRE knob (46) to LOWER position.

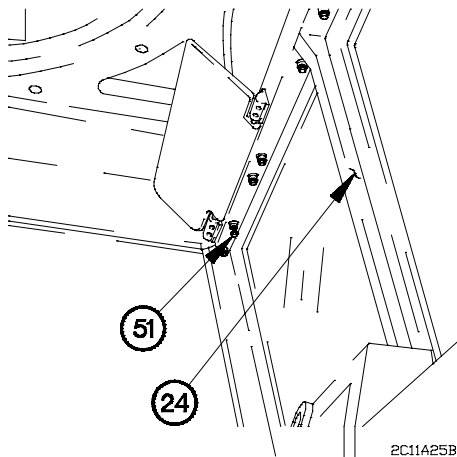
NOTE

Use back-up hydraulic pump (para 2-41) if pressing PUMP knob does not accomplish step (51).

- (51) Press and hold PUMP knob (47).
- (52) Move davit chain (50) inward to stop.
- (53) Lower cab roof (33).
- (54) Remove lifting strap (48) from four brackets (49).



2C11A24B



2C11A25B

NOTE

Do not tighten captive bolts until all ten captive bolts are in position.

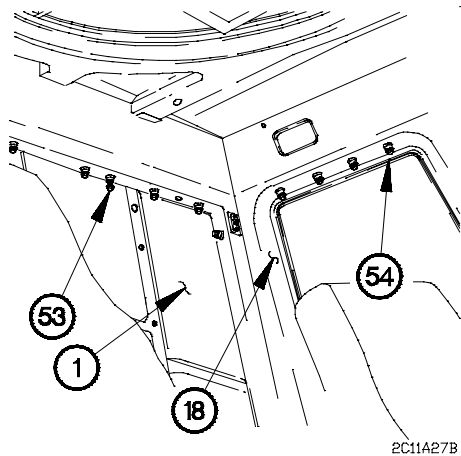
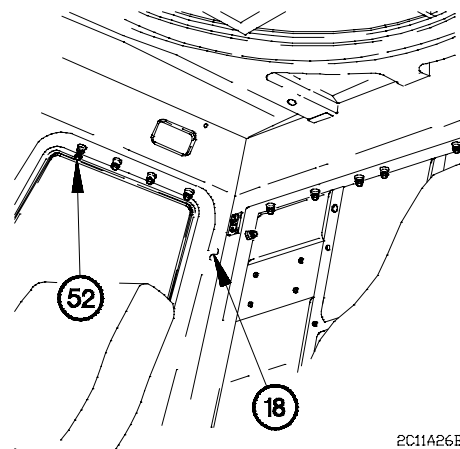
- (55) Position ten captive bolts (51) on windshield (24).
- (56) Tighten ten captive bolts (51).

3-11. M1081 AIR DROP RECOVERY OPERATIONS (CONT)

NOTE

Do not tighten captive bolts until all four captive bolts are in position.

- (57) Position four captive bolts (52) on right side panel (18).
- (58) Tighten four captive bolts (52).



NOTE

Do not tighten captive bolts until all ten captive bolts are in position.

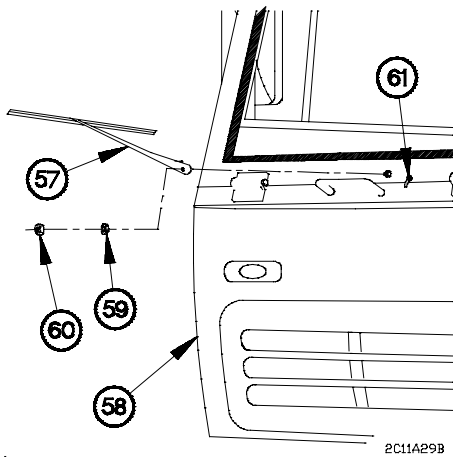
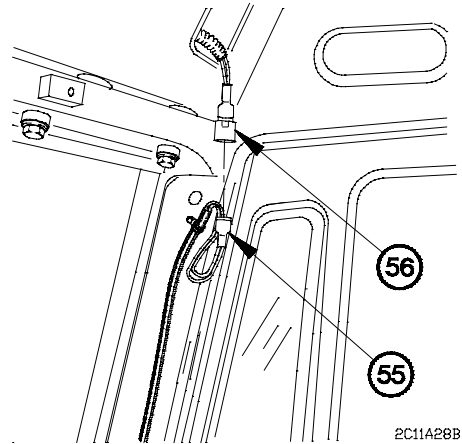
- (59) Position ten captive bolts (53) on rear panel (1).
- (60) Tighten ten captive bolts (53).

NOTE

Do not tighten captive bolts until all ten captive bolts are in position.

- (61) Position four captive bolts (54) on left side panel (18).
- (62) Tighten four captive bolts (54).

- (63) Connect connector J3 (55) to connector P3 (56).



NOTE

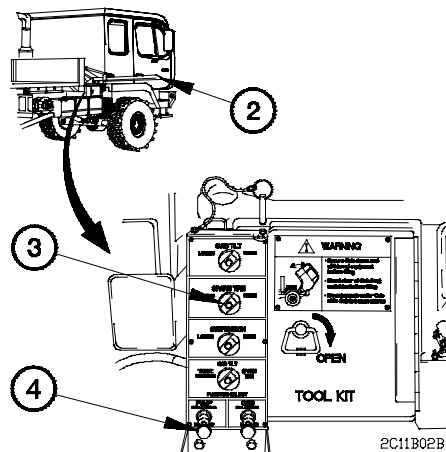
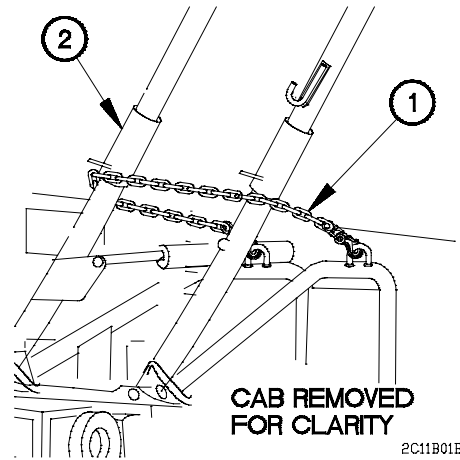
Left and right windshield wiper arms are installed the same way. Right side shown.

- (64) Install windshield wiper arm (57) on cab (58) with lockwasher (59) and nut (60).
- (65) Install windshield wiper tube (61) on windshield wiper arm (57).

3-11. M1081 AIR DROP RECOVERY OPERATIONS (CONT)

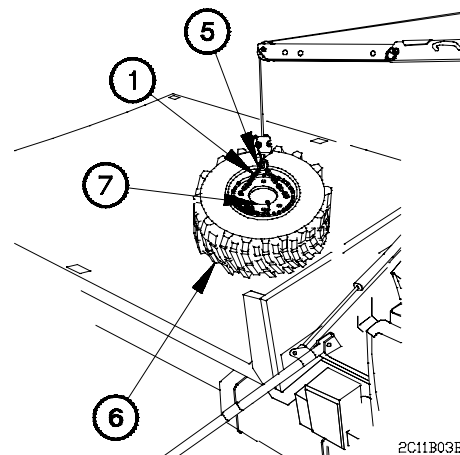
b. Spare Tire Recovery (Vehicles Equipped With Machine Gun Ring).

- (1) Remove safety chain (1) from spare tire retainer lift arm (2).



- (2) Turn SPARE TIRE knob (3) to LOWER position.
- (3) Press and hold PUMP knob (4) until spare tire retainer lift arm (2) is lowered.

- (4) Position LMHC hook (5) over center of spare tire (6).
- (5) Connect safety chain (1) to spare tire wheel hub (7).
- (6) Connect safety chain (1) to LMHC hook (5).



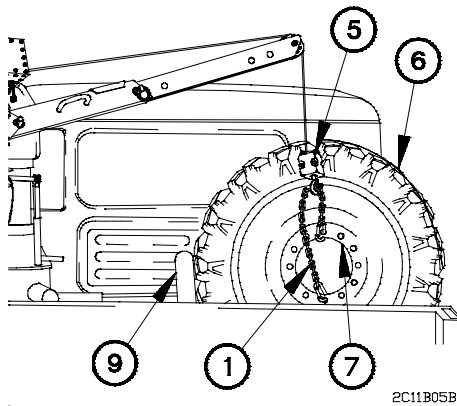
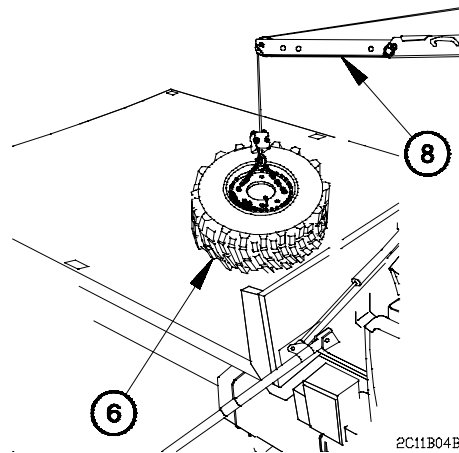
WARNING

Tire weighs approximately 350 lbs (159 kgs). Use extreme care when handling tire. Failure to comply may result in injury to personnel.

NOTE

Steps (7) through (9) require the aid of an assistant.

- (7) Raise spare tire (6) with LMHC (8).



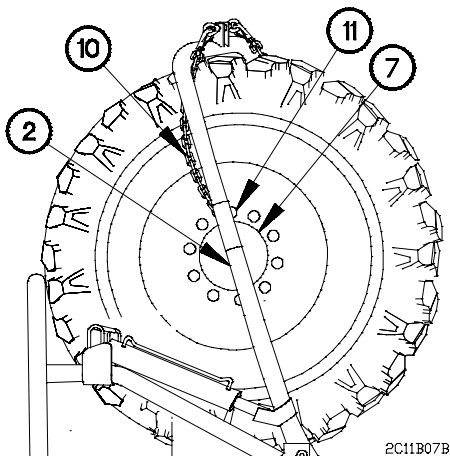
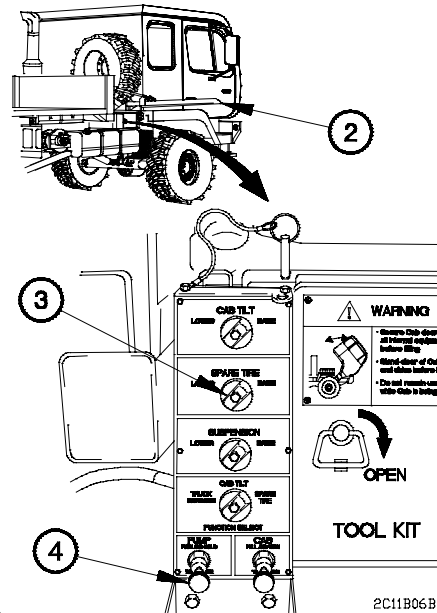
NOTE

CTIS valve on tire must be positioned to the front of vehicle and at the 6 o'clock position.

- (8) Position spare tire (6) over spare tire retainer (9).
- (9) Lower spare tire (6) to spare tire retainer (9).
- (10) Disconnect safety chain (1) from LMHC hook (5).
- (11) Remove safety chain (1) from spare tire wheel hub (7).

3-11. M1081 AIR DROP RECOVERY OPERATIONS (CONT)

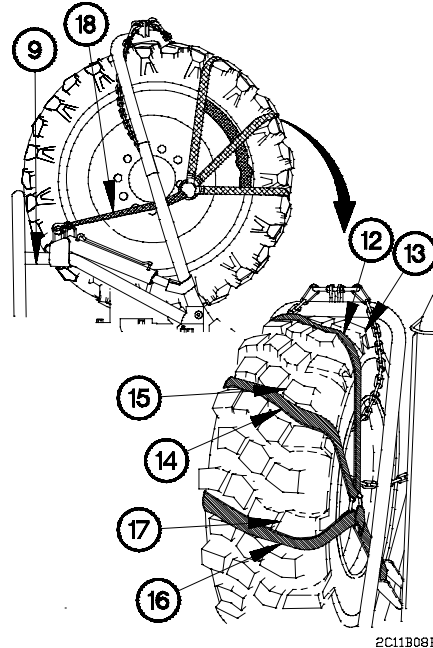
- (12) Raise cab (para 2-22a).
- (13) Turn SPARE TIRE knob (3) to RAISE position.
- (14) Press and hold PUMP knob (4) until spare tire retainer lift arm (2) is raised.



- (15) Disconnect chain (10) from spare tire retainer lift arm (2).
- (16) Route chain (10) through uppermost lug hole (11) in wheel hub (7).
- (17) Connect chain (10) to spare tire retainer lift arm (2).

CAUTION

- Tread engagers must be in slots of tire treads. A loose strap will allow tire to move causing chafing of strap and possible loss of tire. Failure to comply may result in damage to equipment.
 - Tread engagers must not be snug at installation for proper fit, but strap must have a tight fit. Failure to comply may result in damage to equipment.
- (18) Position tread engager (12) in third tread (13), tread engager (14) in sixth tread (15), and tread engager (16) in ninth tread (17).
- (19) Connect strap (18) to spare tire retainer (9).

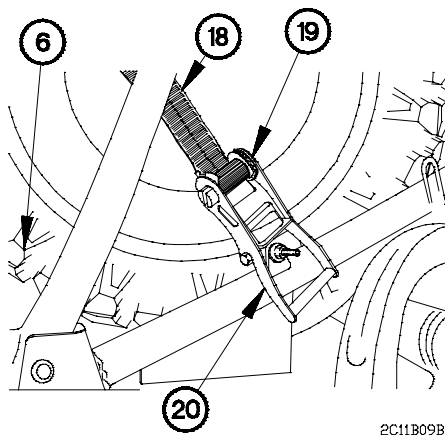


- (20) Feed other end of strap (18) through ratchet (19).

CAUTION

Ensure that strap is wrapped around ratchet at least three complete wraps after tightening. Failure to comply may result in damage to equipment.

- (21) Tighten strap (18) around spare tire (6) with ratchet (19) and close latch (20).

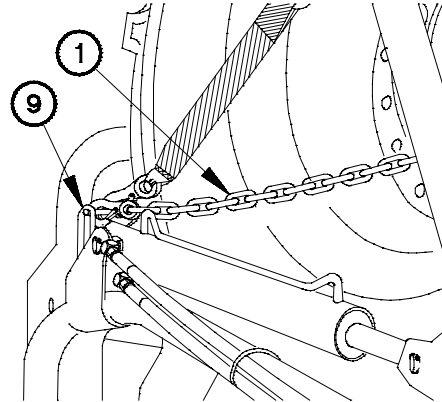


3-11. M1081 AIR DROP RECOVERY OPERATIONS (CONT)

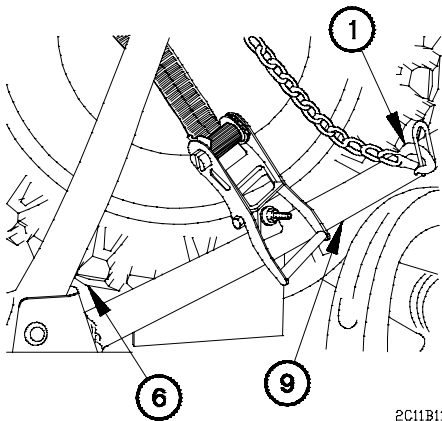
CAUTION

Ensure that safety chain is loose. If safety chain is tight then strap is not tight enough. Failure to comply may result in damage to equipment.

- (22) Connect safety chain (1) to spare tire retainer (9).



2C11B10B



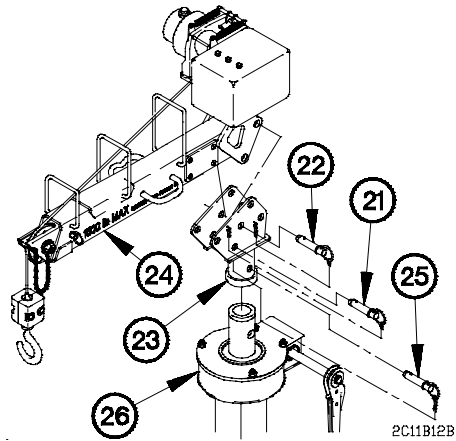
2C11B11B

- (23) Route other end of safety chain (1) through spare tire (6) and connect to spare tire retainer (9).
- (24) Lower cab (para 2-22b).
- (25) Disconnect remote control and power cable connectors (para 2-24d).

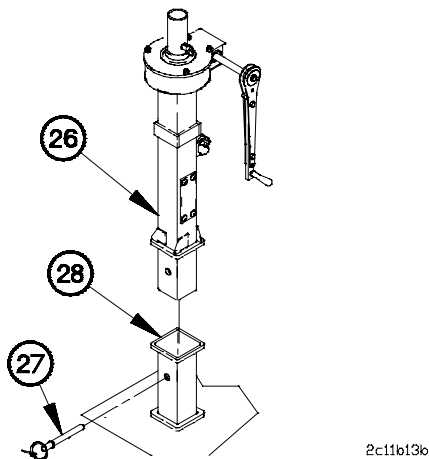
- (26) Remove quick release pins (21 and 22) from turret (23).

WARNING

LMHC boom and winch weighs approximately 110 lbs (50 kgs). The aid of an assistant is required to remove LMHC boom and winch. Failure to comply may result in injury to personnel or damage to equipment.

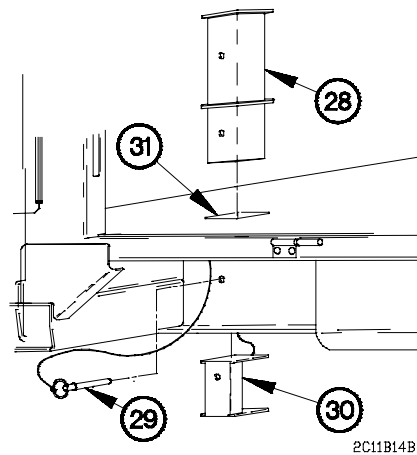


- (27) Remove boom (24) from turret (23).
- (28) Remove quick release pin (25) from turret (23).
- (29) Remove turret (23) from mast (26).



- (30) Remove quick release pin (27) and mast (26) from LMHC extension (28).

- (31) Remove quick release pin (29), plug (30), and LMHC extension (28) from crane pocket (31).
- (32) Install plug (30) in crane pocket (31) with quick release pin (29).

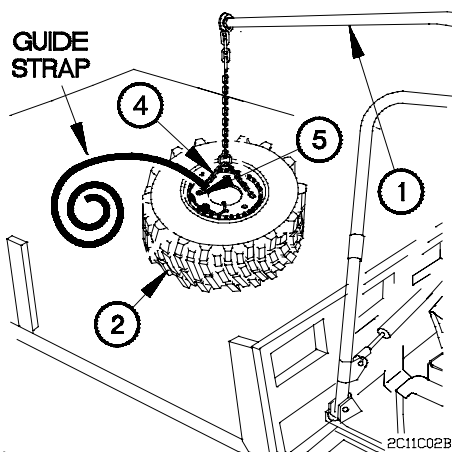
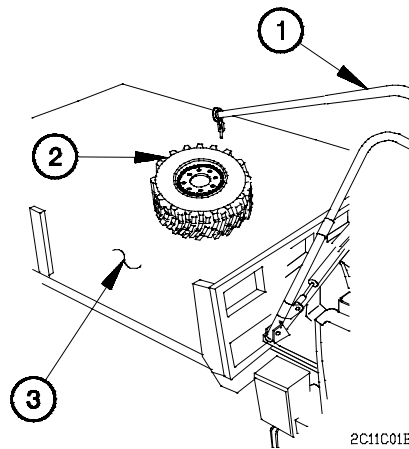


c. Spare Tire Recovery. (Vehicles Not Equipped with Machine Gun Ring).

NOTE

Steps (1) through (19) require the aid of an assistant.

- (1) Position davit (1) over spare tire (2) in cargo bed (3).



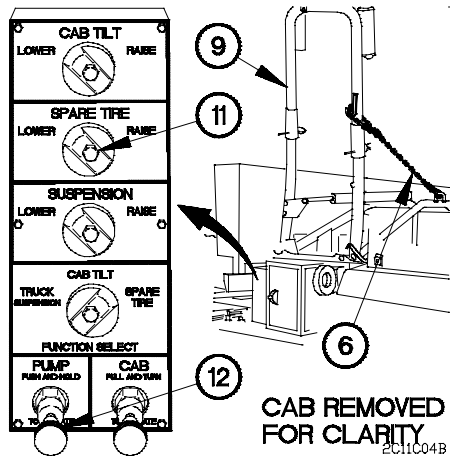
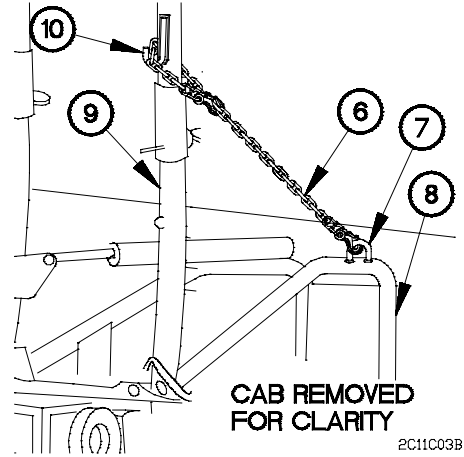
WARNING

Tire weighs approximately 350 lbs (159 kgs). Use extreme care when handling tire. Failure to comply may result in injury to personnel.

- (2) Install chain (4) through two lug stud holes (5).
- (3) Lower davit (1) and attach chain (4) to davit.
- (4) Attach guide strap to spare tire (2).

3-11. M1081 AIR DROP RECOVERY OPERATIONS (CONT)

- (5) Attach chain (6) to hook (7) on spare tire retainer (8).
- (6) Wrap other end of chain (6) around spare tire retainer lift arm (9) above hook (10) and hook chain back to itself.



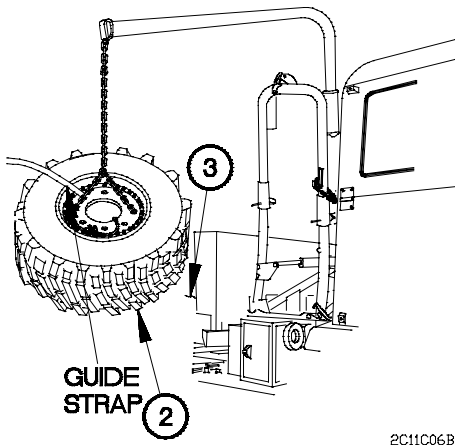
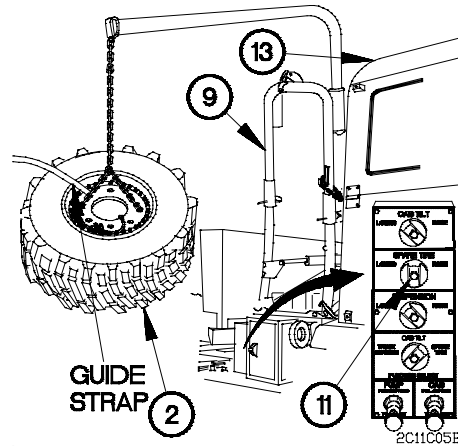
- (7) Turn SPARE TIRE knob (11) to LOWER position.

NOTE

Use back-up hydraulic pump (para 2-41) if pressing PUMP knob does not accomplish step (8).

- (8) Press and hold PUMP knob (12).
- (9) Lower spare tire retainer lift arm (9) until tension is on chain (6).

- (10) Raise spare tire (2) until spare tire retainer lift arm (9) is aligned with right corner of cab (13).
- (11) Turn SPARE TIRE knob (11) mid-way between RAISE and LOWER position to lock spare tire retainer lift arm (9) in place.



WARNING

Manifold operator must stand near hydraulic manifold and observe spare tire while spare tire is being lowered from cargo bed. Spare tire will gain momentum as it is being released. Failure to comply may result in serious injury or death to personnel.

NOTE

Guide person should guide spare tire off cargo bed while standing on ground.

- (12) Swing spare tire (2) off cargo bed (3).

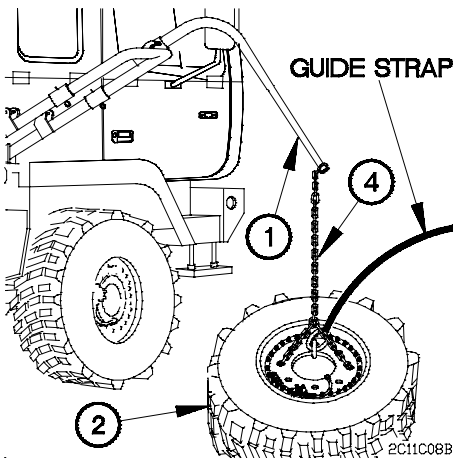
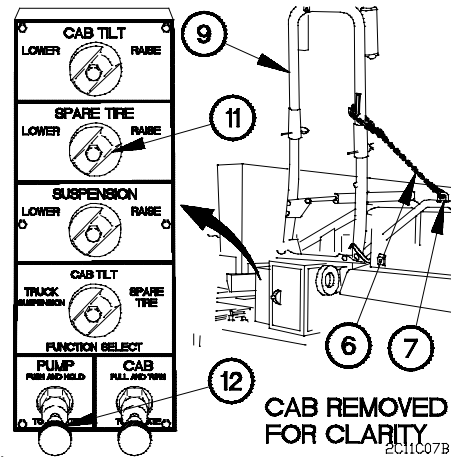
3-11. M1081 AIR DROP RECOVERY OPERATIONS (CONT)

- (13) Turn SPARE TIRE knob (11) to RAISE position.

NOTE

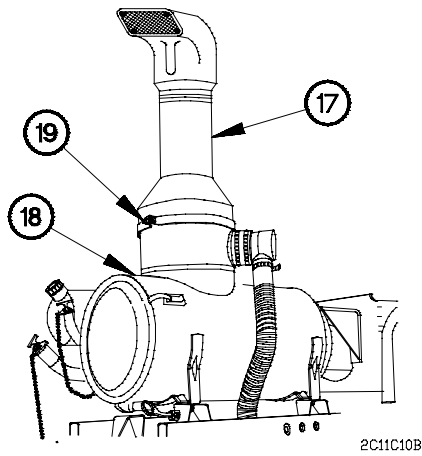
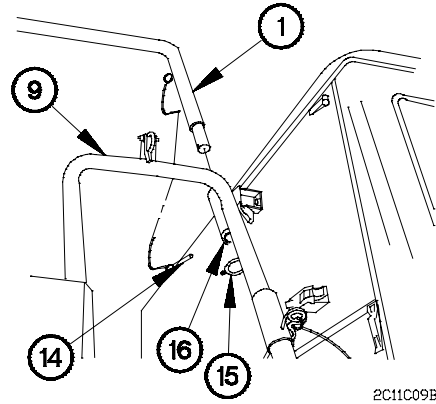
Use back-up hydraulic pump (para 2-41) if pressing PUMP knob does not accomplish step (8).

- (14) Press and hold PUMP knob (12) until chain (6) is slack.
- (15) Remove chain (6) from hook (7) and from spare tire retainer lift arm (9).



- (16) Lower spare tire (2) to the ground.
- (17) Remove guide strap from spare tire (2).
- (18) Remove chain (4) from davit (1) and spare tire (2).

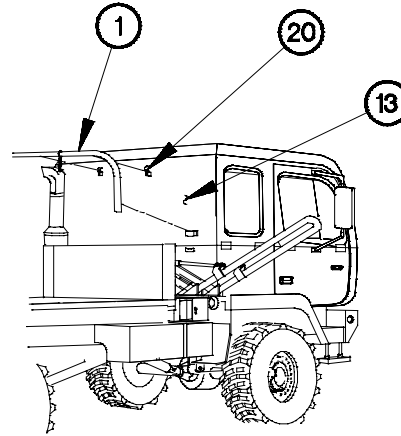
- (19) Remove safety pin (14) and safety washer (15) from davit (1).
- (20) Remove davit (1) from sleeve (16) on spare tire retainer lift arm (9).
- (21) Install safety washer (15) and safety pin (14) on bottom of davit (1).



- (22) Position air intake adapter (17) on inlet air cleaner housing (18) and tighten clamp (19).

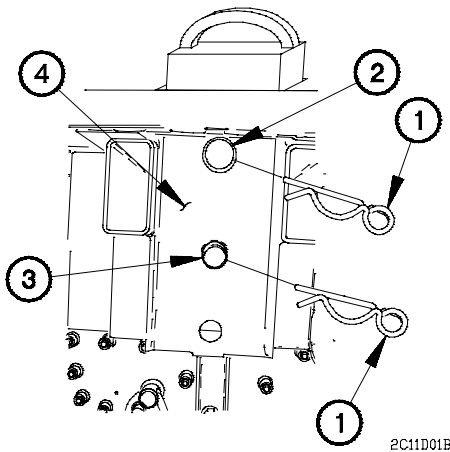
3-11. M1081 AIR DROP RECOVERY OPERATIONS (CONT)

- (23) Stow davit (1) on back of cab (13) and close three clamps (20).
- (24) Stow spare tire (para 3-5e).



2C11C11B

d. Slide Assembly Recovery.



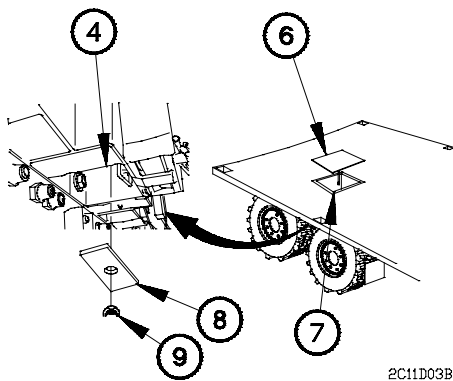
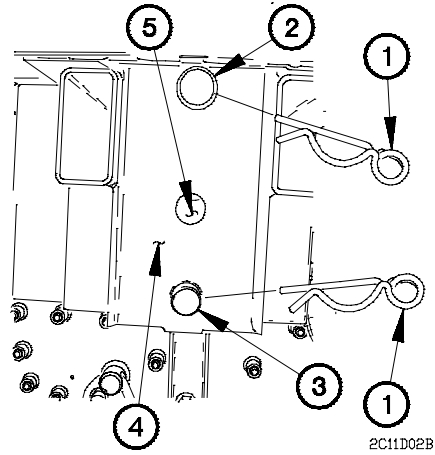
2C11D01B

NOTE

Steps (1) through (10) require the aid of an assistant.

- (1) Remove safety pins (1) from large pin (2) and small pin (3).
- (2) Remove small pin (3) from middle hole of slide assembly receptacle (4).

- (3) Remove large pin (2) from slide assembly (5).
- (4) Lower slide assembly (5) in slide assembly receptacle (4).
- (5) Install small pin (3) in bottom hole of slide assembly receptacle (4) and slide assembly (5).
- (6) Install large pin (2) in large hole of slide assembly receptacle (4).
- (7) Install two safety pins (1) in large pin (2) and small pin (3).



- (8) Install cover plate assembly (6) in slide assembly receptacle (4) in cargo bed (7).
- (9) Install retaining bar (8) on rod of cover plate assembly (6).
- (10) Install wing nut (9) on rod of cover plate assembly (6).

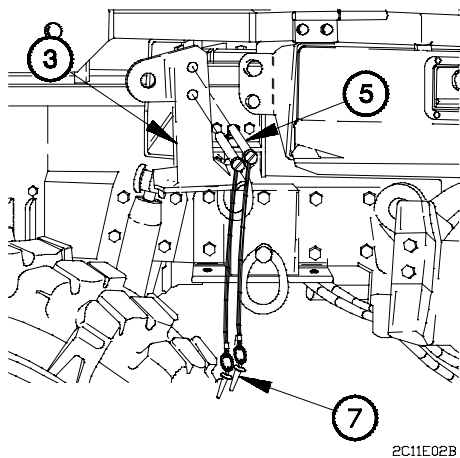
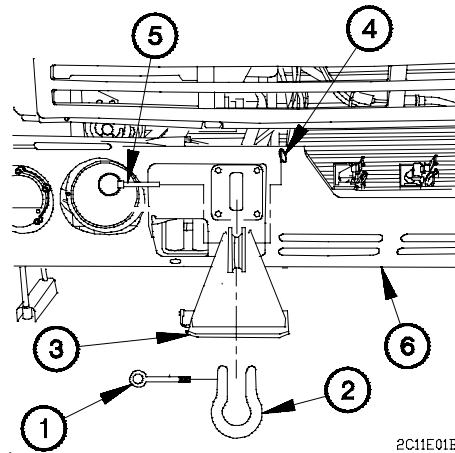
3-11. M1081 AIR DROP RECOVERY OPERATIONS (CONT)

e. Load Spreader Recovery.

NOTE

- Left and right side load spreaders are installed the same way. Right side shown.
- Steps (1) through (5) require the aid of an assistant.

- (1) Remove pin (1) and shackle (2) from front load spreader (3).
- (2) Remove two safety pins (4), two pins (5), and front load spreader (3) from front bumper (6).
- (3) Install shackle (2) and pin (1) on front bumper (6).



- (4) Position front load spreader (3) and two pins (5) on stowage location on vehicle.
- (5) Install two safety pins (7) on two pins (5).

f. Follow-On Maintenance.

- (1) Install side panels (para 2-26e).
- (2) Remove wheel chocks (para 2-21h).
- (3) Notify Unit Maintenance to torque air intake adapter clamp in accordance with maintenance paragraph.
- (4) Notify Unit Maintenance to tighten nuts on mirror to 21-27 lb-ft (29-37 N-m).

End of Task.

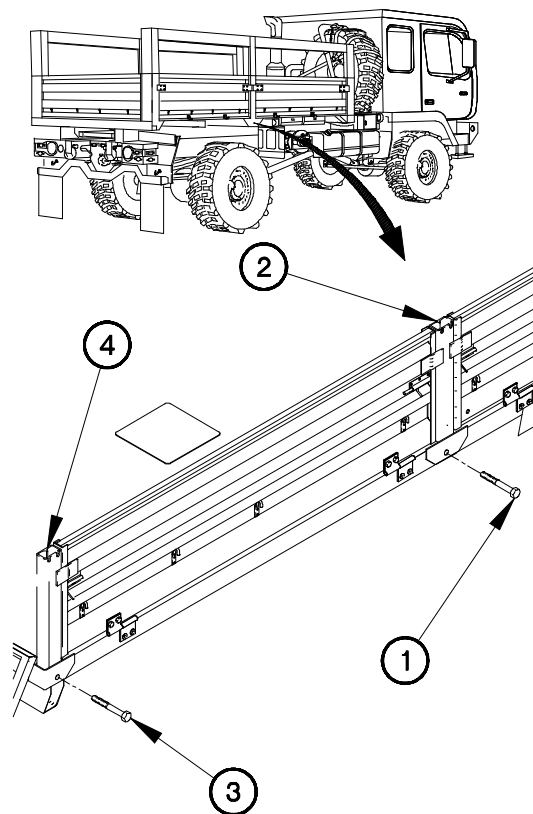
3-12. TROOPSEAT KIT INSTALLATION/REMOVAL (UNMODIFIED)	
This task covers:	
a. Installation	b. Removal
INITIAL SETUP	
Equipment Conditions Engine shut down (para 2-21f).	Tools and Special Tools (Cont) Screwdriver, Flattip (Item 13, Appendix B) Wrench, Adjustable (Item 16, Appendix B)
	Personnel Required (2)

a. Installation.

NOTE

Left and right side bolts are installed in cargo bed stakes the same way. Right side shown.

- (1) Position bolt (1) in center cargo bed stake (2).
- (2) Position bolt (3) in rear cargo bed stake (4).



1C12A01A

**3-12. TROOPSEAT KIT INSTALLATION/REMOVAL (UNMODIFIED)
(CONT)**

CAUTION

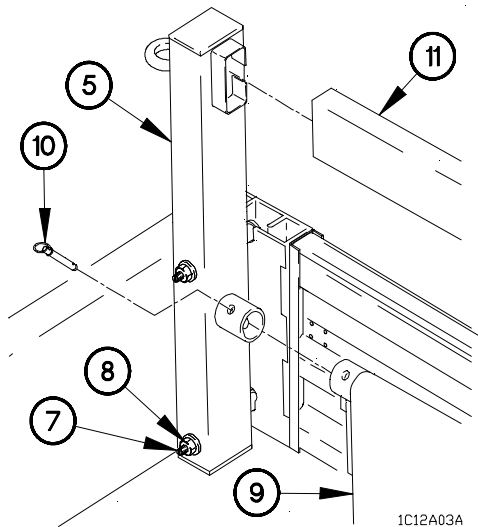
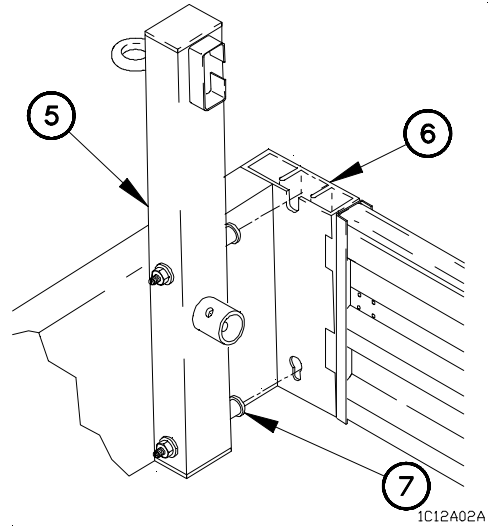
Ensure seat post is flush with cargo bed floor prior to tightening bolts. Failure to comply may result in damage to equipment.

NOTE

Left and right troopseats are installed the same way. Right side shown.

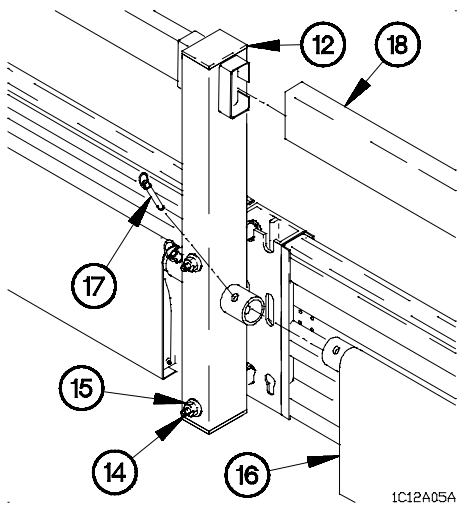
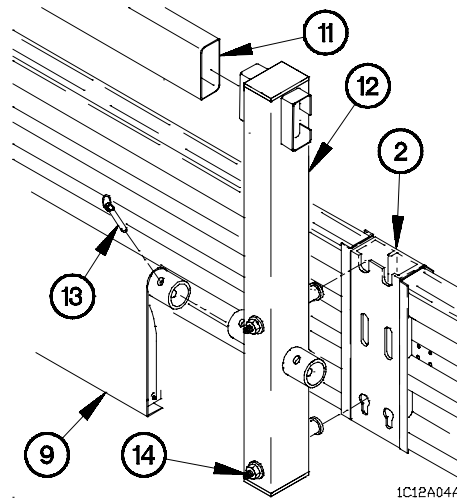
Steps (3) through (22) require the aid of an assistant.

- (3) Attach front seat post (5) to front cargo bed stake (6) with two bolts (7).



- (4) Hold bolts (7).
- (5) Install two nuts (8) on bolts (7).
- (6) Install front seats (9) on front seat post (5).
- (7) Insert quick release pin (10) in front seats (9).
- (8) Install backrest (11) on front seat post (5).

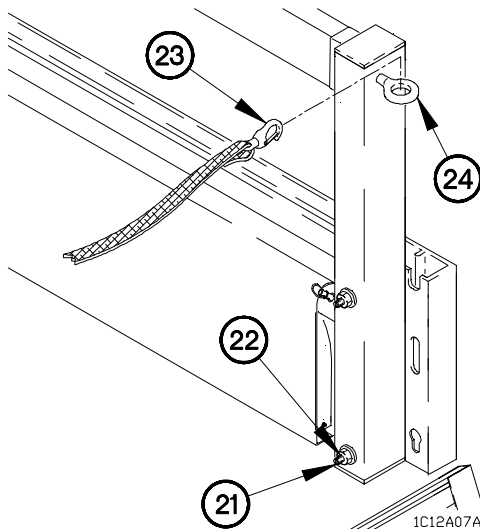
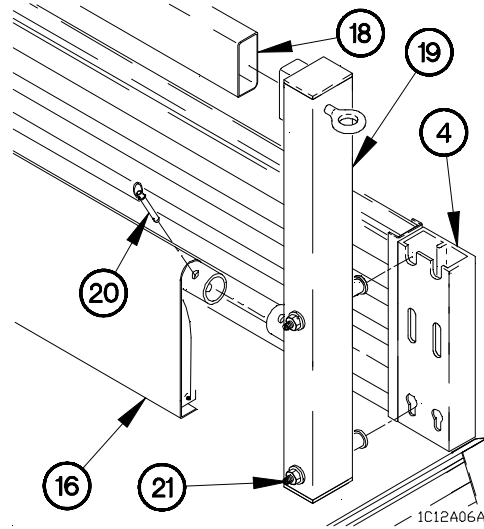
- (9) Install center seat post (12) on backrest (11) and front seats (9).
- (10) Insert quick release pin (13) in front seats (9).
- (11) Attach center seat post (12) to center cargo bed stake (2) with two bolts (14).



- (12) Hold bolts (14) with screwdriver.
- (13) Install two nuts (15) on bolts (14).
- (14) Install rear seats (16) on center seat post (12).
- (15) Insert quick release pin (17) in rear seats (16).
- (16) Install backrest (18) on center seat post (12).

**3-12. TROOPSEAT KIT INSTALLATION/REMOVAL (UNMODIFIED)
(CONT)**

- (17) Install rear seat post (19) on backrest (18) and rear seats (16).
- (18) Insert quick release pin (20) in rear seats (16).
- (19) Attach rear seat post (19) to rear cargo bed stake (4) with two bolts (21).



(20) Hold bolts (21).

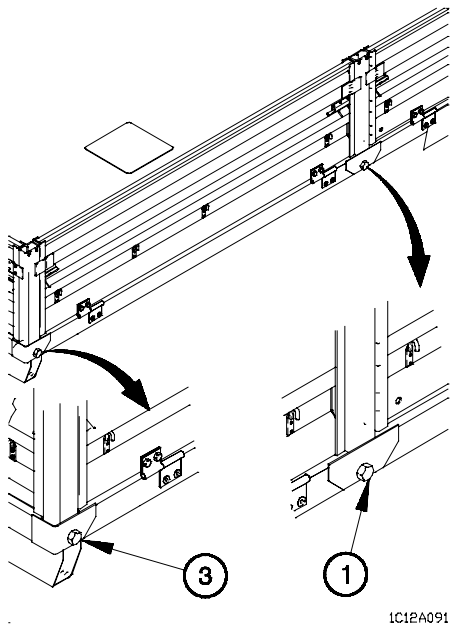
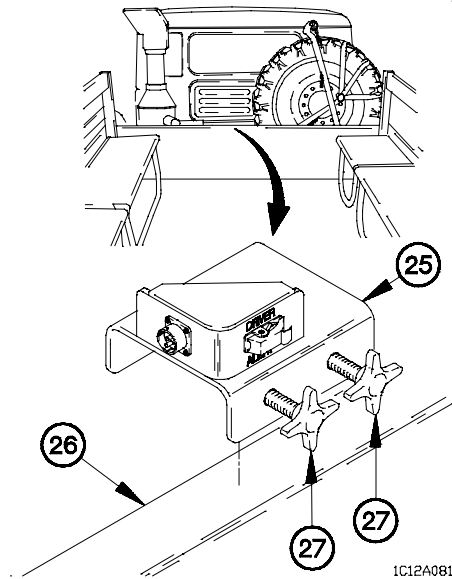
(21) Install two nuts (22) on bolts (21).

NOTE

All four safety strap hooks are installed the same way. Right rear safety strap hook shown.

(22) Install safety strap hook (23) in eyebolt (24).

- (23) Install alarm bracket (25) on cargo bed (26) with two knobs (27).
- (24) Notify Unit Maintenance to install troop transport alarm cable assembly.

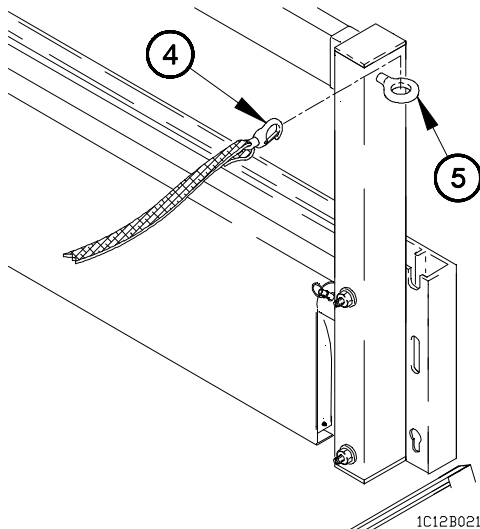
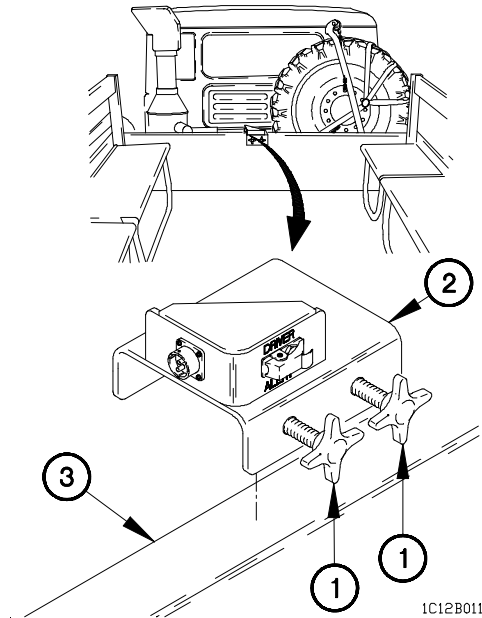


- (25) Notify Unit Maintenance to tighten bolt (1) and bolt (3) to 46-57 lb-ft (62-77 N·m).

3-12. TROOPSEAT KIT INSTALLATION/REMOVAL (UNMODIFIED) (CONT)

b. Removal.

- (1) Notify Unit Maintenance to remove troop transport alarm cable assembly.
- (2) Loosen two knobs (1) on alarm bracket (2).
- (3) Remove alarm bracket (2) from cargo bed (3).



NOTE

All four safety strap hooks are removed the same way. Right rear safety strap hook shown.

- (4) Remove safety strap hook (4) from eyebolt (5).

NOTE

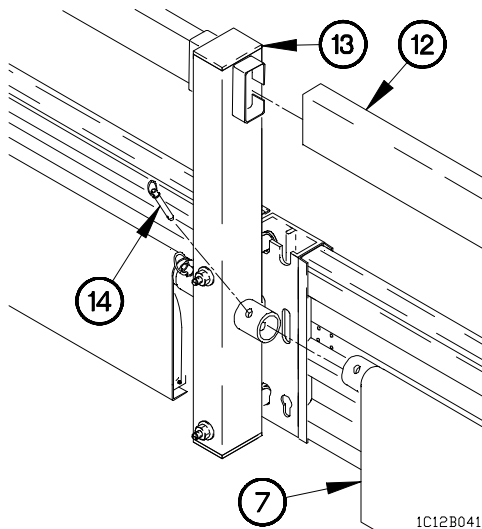
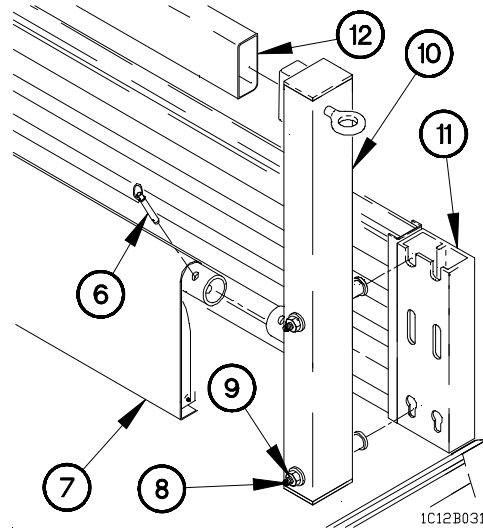
- Left and right troopseats are removed the same way. Right side shown.
- Steps (5) through (24) require the aid of an assistant.

- (5) Remove quick release pin (6) from rear seats (7).

NOTE

Loosen nuts enough to remove seat post from stake.

- (6) Hold two bolts (8).
- (7) Loosen two nuts (9) on bolts (8).
- (8) Remove seat post (10) from rear cargo bed stake (11), backrest (12), and rear seats (7).



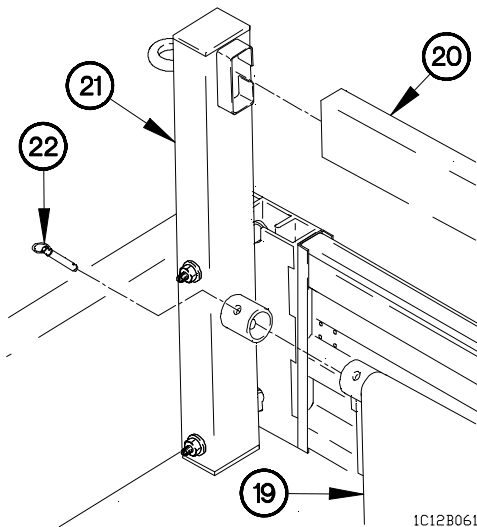
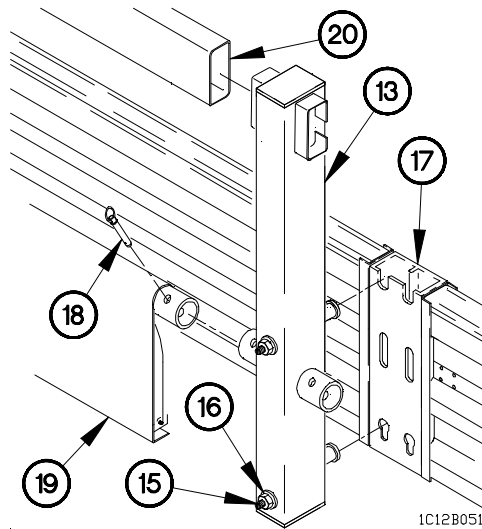
- (9) Remove backrest (12) from center seat post (13).
- (10) Remove quick release pin (14) from rear seats (7).
- (10) Remove rear seats (7) from center seat post (13).

3-12. TROOPSEAT KIT INSTALLATION/REMOVAL (UNMODIFIED) (CONT)

NOTE

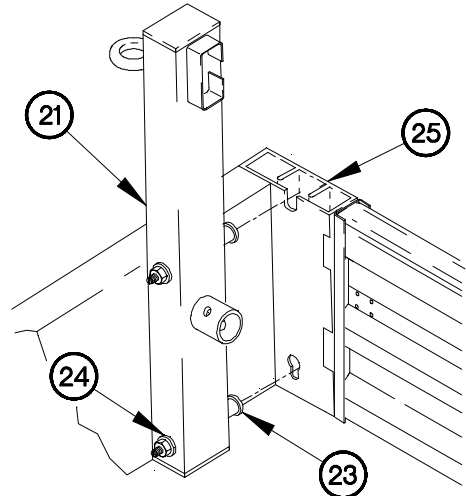
Loosen nuts enough to remove seat post from stake.

- (12) Hold two bolts (15).
- (13) Loosen two nuts (16) on bolts (15).
- (14) Remove center seat post (13) from center cargo bed stake (17).
- (15) Remove quick release pin (18) from front seats (19).
- (16) Remove center seat post (13) from backrest (20) and front seats (19).

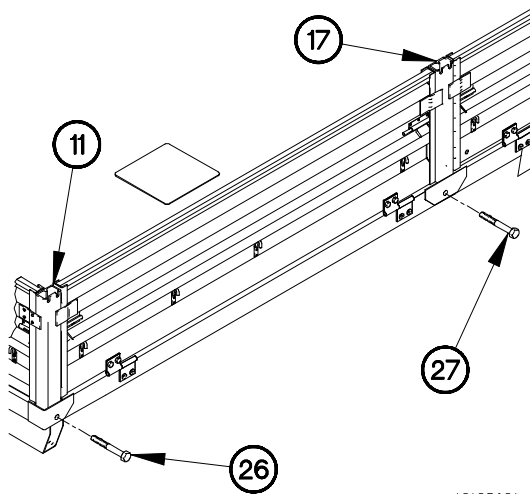


- (17) Remove backrest (20) from front seat post (21).
- (18) Remove quick release pin (22) from front seats (19).
- (19) Remove front seats (19) from front seat post (21).

- (20) Hold two bolts (23).
- (21) Loosen two nuts (24) on bolts (23).
- (22) Remove front seat post (21) from front cargo bed stake (25).



1C12B071



1C12B081

NOTE

Left and right side bolts are removed from cargo bed stakes the same way. Right side shown.

- (23) Remove bolt (26) from rear cargo bed stake (11).
- (24) Remove bolt (27) from center cargo bed stake (17).

End of Task.

3-13. POWER DISTRIBUTION PANEL (PDP) COVER REMOVAL/INSTALLATION

This task covers:

a. Removal

b. Installation

INITIAL SETUP

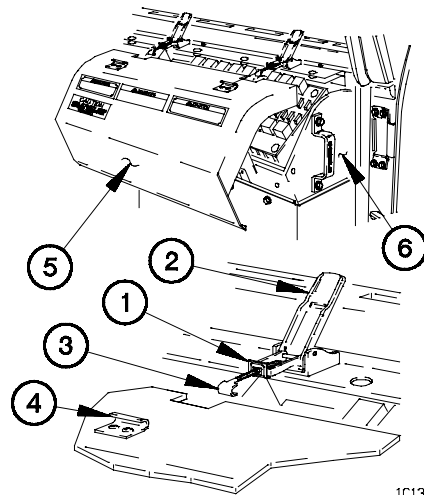
Engine shut down (2-21g).

a. Removal.

- (1) Pull two spring catches (1) and lift two latch levers (2).
- (2) Release two latch hooks (3) from two strike plates (4).
- (3) Remove PDP cover (5) from dashboard (6).

b. Installation.

- (1) Position PDP cover (5) on dashboard (6).
- (2) Fasten two latch hooks (3) on two strike plates (4).
- (3) Push down on two latch levers (2) until spring catches (1) are engaged.



1C13A011

End of Task.

3-14. REAR SPRING BRAKE CAGING

This task covers:

- a. Caging
- b. Uncaging
- c. Follow-On Maintenance

INITIAL SETUP

Equipment Conditions

Engine shut down (para 2-21f).

Tools and Special Tools (Cont)

Wrench, Adjustable, 8 in. (Item 16, Appendix B)

Tools and Special Tools

Goggles, Industrial (Item 24, Appendix B) (366 number, add to 365, Appendix B)

Personnel Required

(2)

WARNING

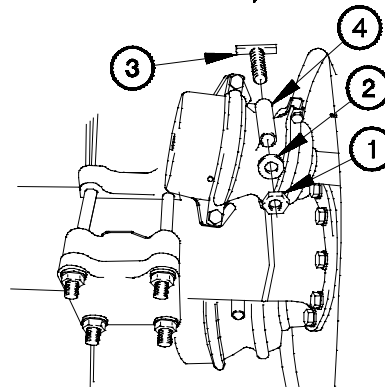
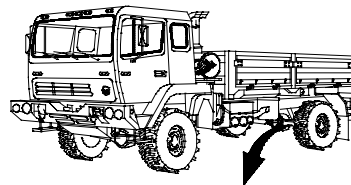
Wear appropriate eye protection when working under vehicle due to the possibility of falling debris. Failure to comply may result in injury to personnel.

a. Caging.

NOTE

To cage brakes, apply caging procedure to both top and bottom spring brake chambers.

- (1) Remove nut (1) and washer (2) from caging bolt (3).
- (2) Remove caging bolt (3) from caging bolt holder (4).



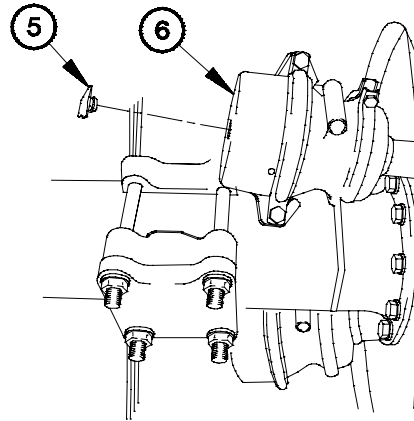
1C14R01B

3-14. REAR SPRING CAGING (CONT)

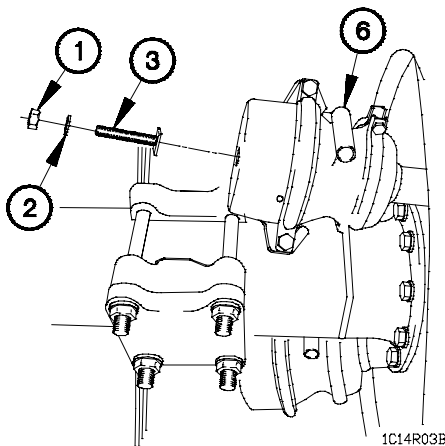
NOTE

Save rubber cap for use after uncaging operation to seal spring brake chamber.

- (3) Remove rubber cap (5) from spring brake chamber (6).



1C14R02B

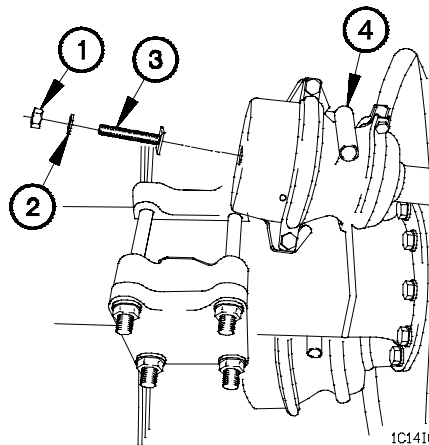


1C14R03B

- (4) Insert T-end of caging bolt (3) in back of spring brake chamber (6).
- (5) Lock caging bolt (3) in place by turning caging bolt to the right 1/4 turn.
- (6) Install washer (2) and nut (1) on caging bolt (3).

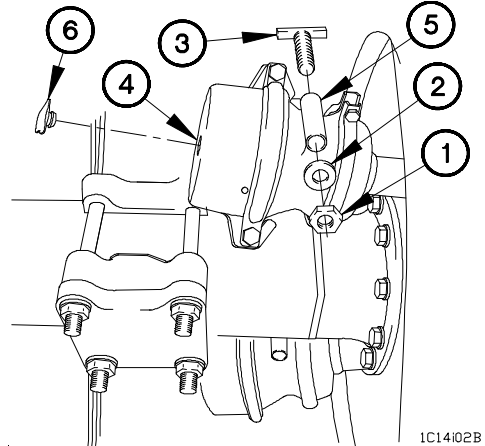
b. Uncaging.

- (1) Remove nut (1) and washer (2) from caging bolt (3).
- (2) Remove caging bolt (3) by turning to the left 1/4 turn.
- (3) Remove caging bolt (3) from spring brake chamber (4).



1C14I01B

- (4) Install caging bolt (3) in caging bolt holder (5).
- (5) Position washer (2) and nut (1) on caging bolt (3).
- (6) Install rubber cap (6) on spring brake chamber (4).



IC14102B

c. Follow-On Maintenance.

Notify Unit Maintenance to tighten nut on caging bolt to 50 lb-ft (68 N·m).

End of Task.



3-15. TROOPSEAT KIT INSTALLATION/REMOVAL (MODIFIED)

This task covers:

- a. Installation
- b. Removal

INITIAL SETUP

Equipment Conditions

Engine shut down (para 2-21f).

Tools and Special Tools (Cont)

Screwdriver, Flattip (Item 13, Appendix B)

Wrench, Adjustable (Item 16, Appendix B)

Personnel Required

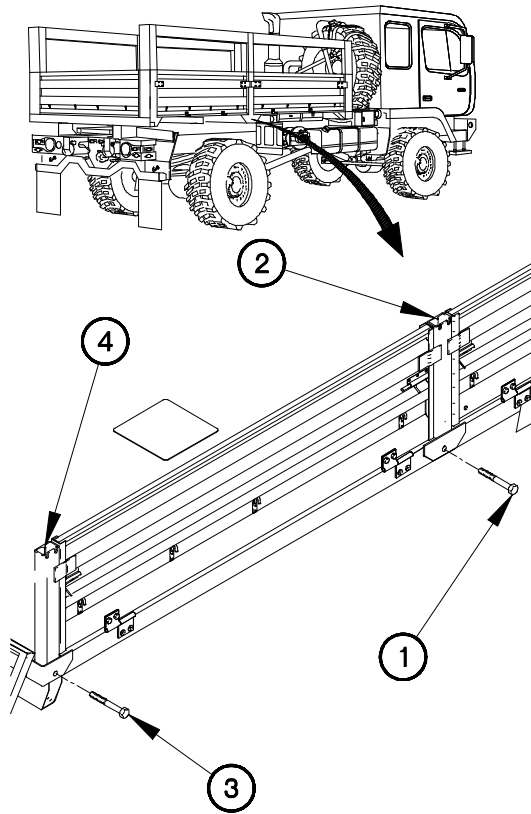
(2)

a. Installation.

NOTE

Left and right side bolts are installed in cargo bed stakes the same way. Right side shown.

- (1) Position bolt (1) in center cargo bed stake (2).
- (2) Position bolt (3) in rear cargo bed stake (4).



1C15A01

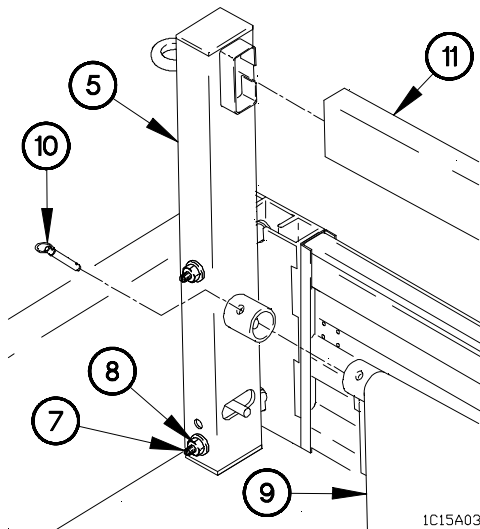
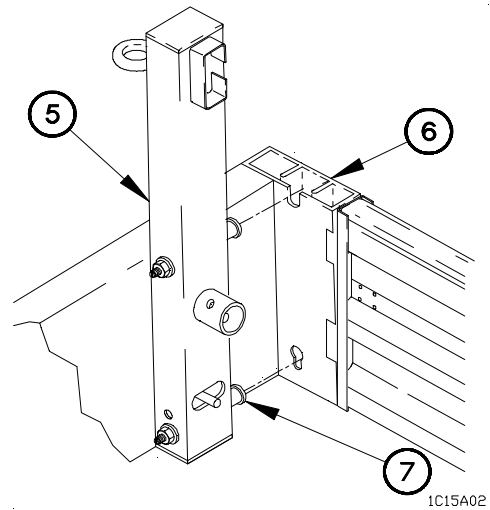
CAUTION

Ensure seat post is flush with cargo bed floor prior to tightening bolts. Failure to comply may result in damage to equipment.

NOTE

- Left and right troopseats are installed the same way. Right side shown.
- Steps (3) through (21) require the aid of an assistant.

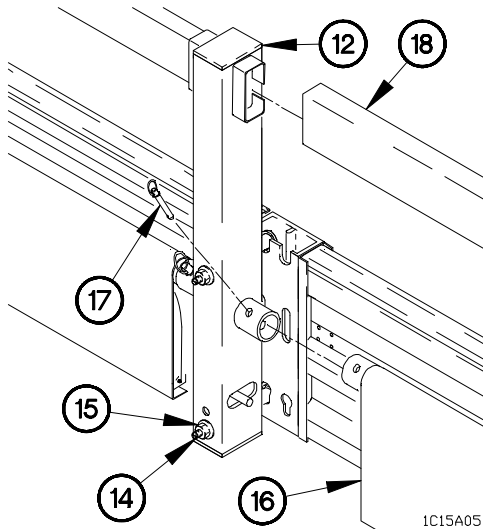
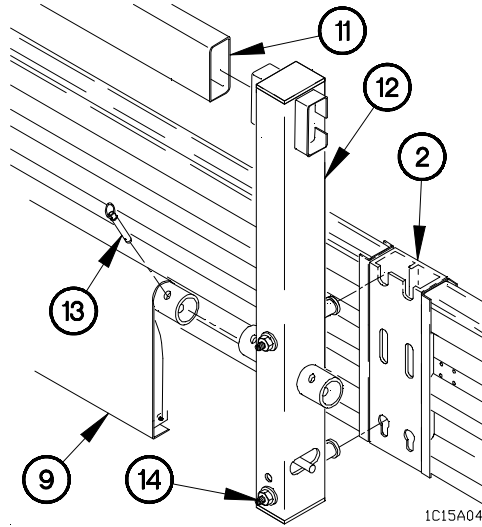
- (3) Attach front seat post (5) to front cargo bed stake (6) with two bolts (7).



- (4) Hold bolts (7).
- (5) Install two nuts (8) on bolts (7).
- (6) Install front seats (9) on front seat post (5).
- (7) Insert quick release pin (10) in front seats (9).
- (8) Install backrest (11) on front seat post (5).

**3-15. TROOPSEAT KIT INSTALLATION/REMOVAL (MODIFIED)
(CONT)**

- (9) Install center seat post (12) on backrest (11) and front seats (9).
- (10) Insert quick release pin (13) in front seats (9).
- (11) Attach center seat post (12) to center cargo bed stake (2) with two bolts (14).

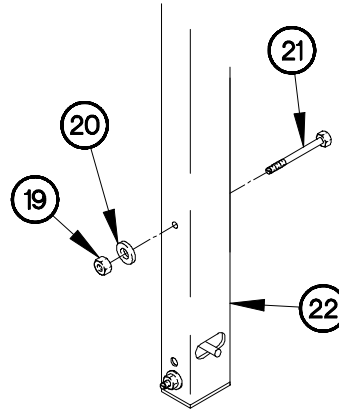


- (12) Hold bolts (14).
- (13) Install two nuts (15) on bolts (14).
- (14) Install rear seats (16) on center seat post (12).
- (15) Insert quick release pin (17) in rear seats (16).
- (16) Install backrest (18) on center seat post (12).

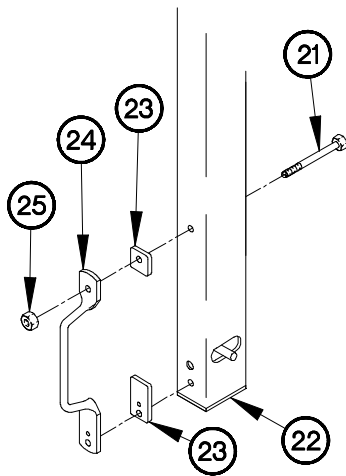
NOTE

Perform steps (17) and (18) on troop seat kits equipped with boarding handles prior to installing rear seat post for the first time.

- (17) Remove two nuts (19), washers (20), and bolts (21) from rear set post (22). Discard nuts and washers.



1C15A06

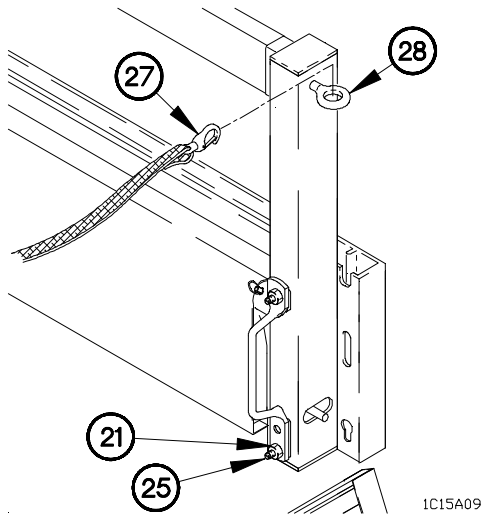
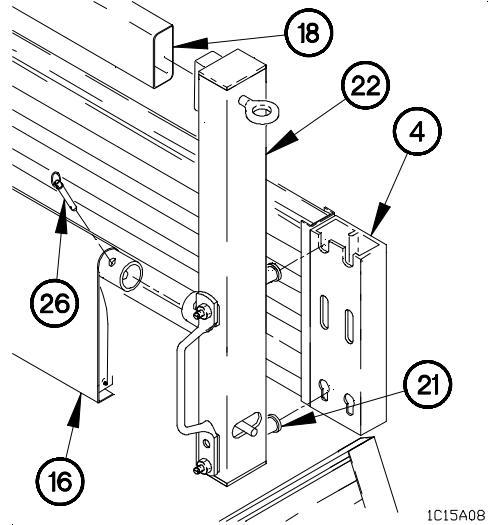


1C15A07

- (18) Position two bolts (21), gaskets (23), handle (24), and two nuts (25) on rear seat post (22).

**3-15. TROOPSEAT KIT INSTALLATION/REMOVAL (MODIFIED)
(CONT)**

- (19) Install rear seat post (22) on backrest (18) and rear seats (16).
- (20) Insert quick release pin (26) in rear seats (16).
- (21) Attach rear seat post (22) to rear cargo bed stake (4) with two bolts (21).



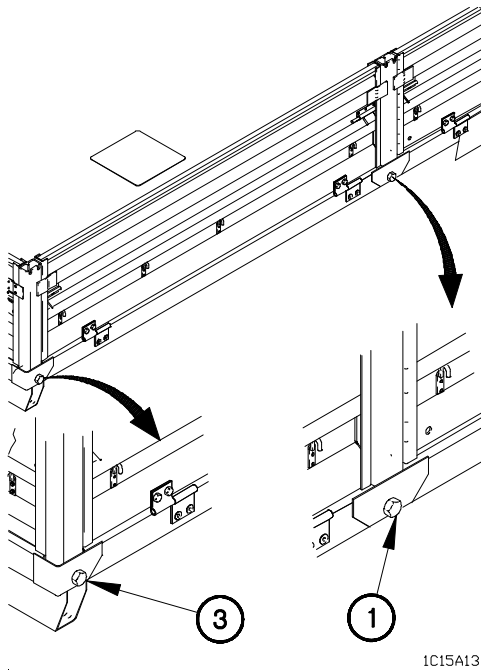
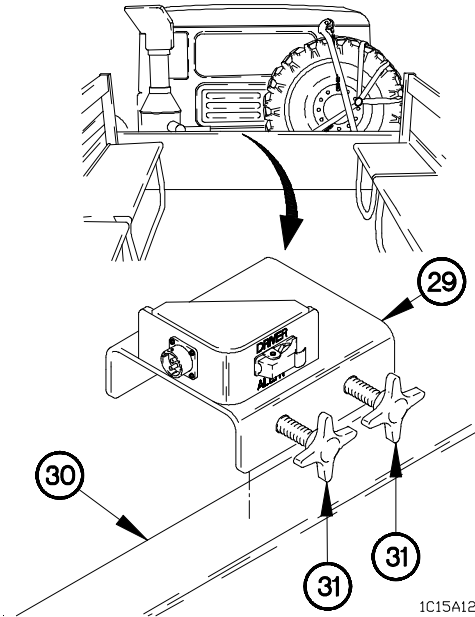
- (22) Tighten two nuts (25) on bolts (21).
- (23) Perform steps (1) through (22) on left side of cargo bed.

NOTE

All four safety strap hooks are installed the same way. Right rear safety strap hook shown.

- (24) Install safety strap hook (27) in eyebolt (28).

- (25) Install alarm bracket (29) on cargo bed (30) with two knobs (31).
- (26) Notify Unit Maintenance to install troop transport alarm cable assembly.

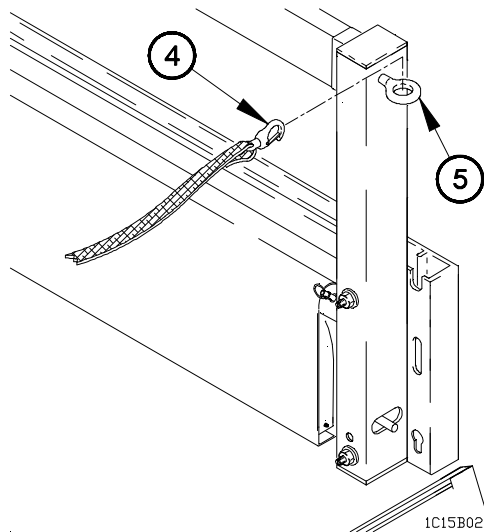
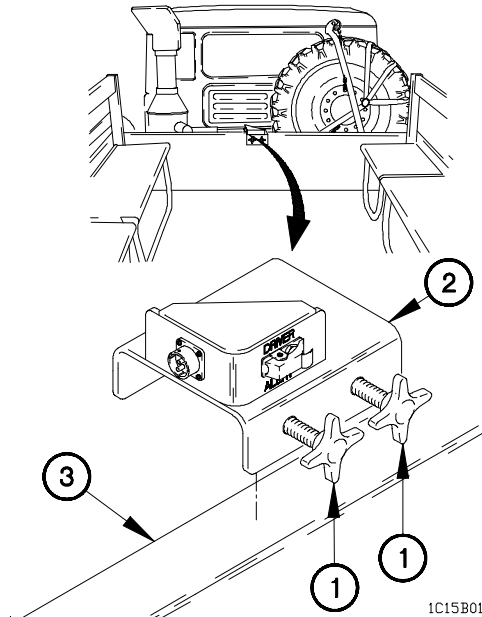


- (27) Notify Unit Maintenance to tighten bolt (1) and bolt (3) to 46-57 lb-ft (62-77 N•m).

**3-15. TROOPSEAT KIT INSTALLATION/REMOVAL (MODIFIED)
(CONT)**

b. Removal.

- (1) Notify Unit Maintenance to remove troop transport alarm cable assembly.
- (2) Loosen two knobs (1) on alarm bracket (2).
- (3) Remove alarm bracket (2) from cargo bed (3).



NOTE

- Left and right troopseats are removed the same way. Right side shown.
 - Eyebolts are located on all corner seat posts. Right rear eyebolt shown.
- (4) Remove safety strap hook (4) from eyebolt (5).

NOTE

Steps (5) through (23) require the aid of an assistant.

- (5) Remove quick release pin (6) from rear seats (7).

NOTE

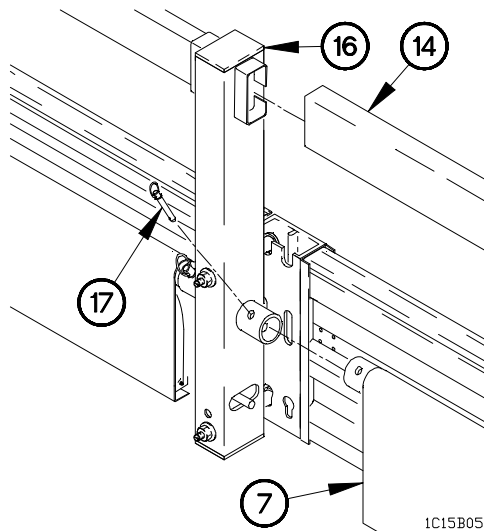
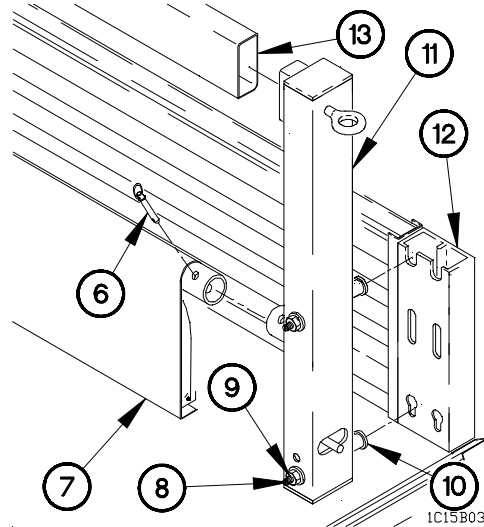
Loosen nuts enough to remove seat post from stake.

- (6) Hold two bolts (8).
- (6) Loosen two nuts (9) on bolts (8).

NOTE

Perform step (7) on seat posts equipped with spring locking pins.

- (8) Pull back on spring locking pin (10).
- (9) Remove seat post (11) from rear cargo bed stake (12), backrest (13), and rear seats (7).



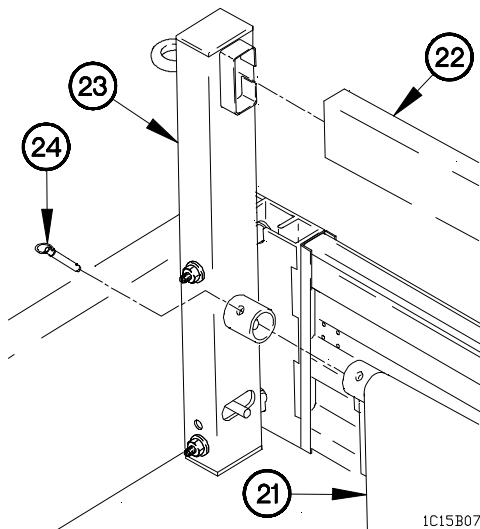
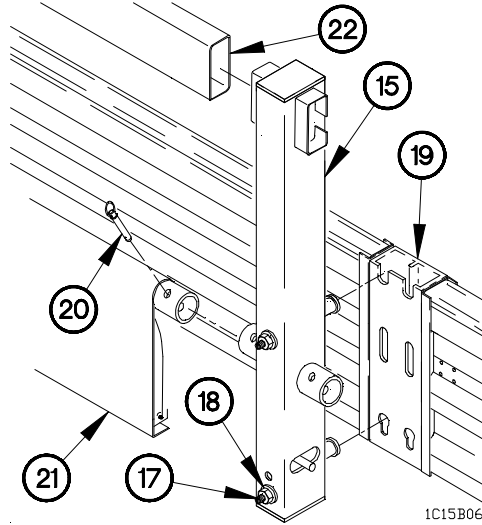
- (10) Remove backrest (14) from center seat post (16).
- (11) Remove quick release pin (17) from rear seats (7).
- (13) Remove rear seats (7) from center seat post (16).

**3-15. TROOPSEAT KIT INSTALLATION/REMOVAL (MODIFIED)
(CONT)**

NOTE

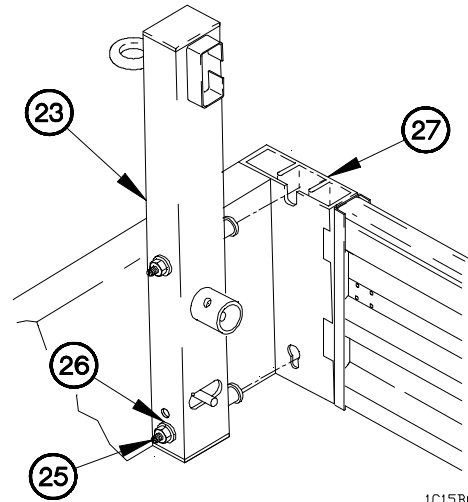
Loosen nuts enough to remove seat post from stake.

- (14) Hold two bolts (17).
- (15) Loosen two nuts (18) on bolts (17).
- (16) Remove center seat post (15) from center cargo bed stake (19).
- (17) Remove quick release pin (20) from front seats (21).
- (18) Remove center seat post (15) from backrest (22) and front seats (21).

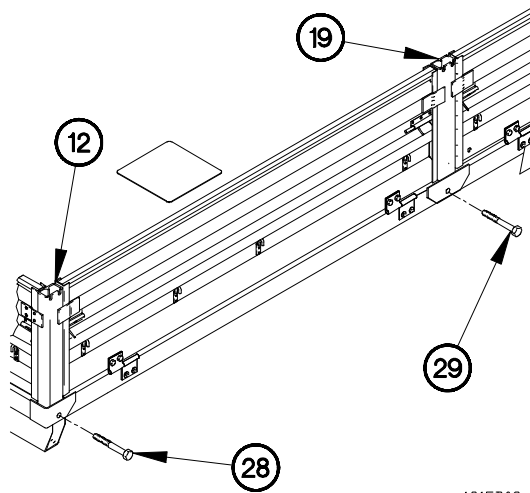


- (19) Remove backrest (22) from front seat post (23).
- (20) Remove quick release pin (24) from front seats (21).
- (21) Remove front seats (21) from front seat post (23).

- (22) Hold two bolts (25).
- (23) Loosen two nuts (26) on bolts (25).
- (24) Remove front seat post (23) from front cargo bed stake (27).



1C15B08



1C15B09

NOTE

Left and right side bolts are removed from cargo bed stakes the same way. Right side shown.

- (27) Remove bolt (28) from rear cargo bed stake (12).
- (28) Remove bolt (29) from center cargo bed stake (19).

End of Task.

3-16. BUMPERETTE KIT INSTALLATION/REMOVAL

This task covers:

- a. Installation
- b. Removal

INITIAL SETUP

Equipment Conditions
 Engine shut down (para 2-21f).

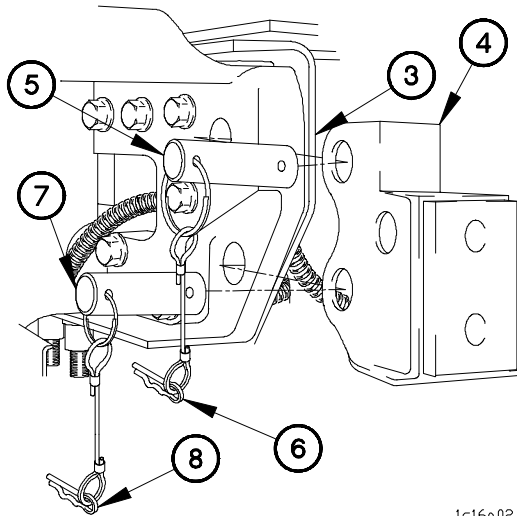
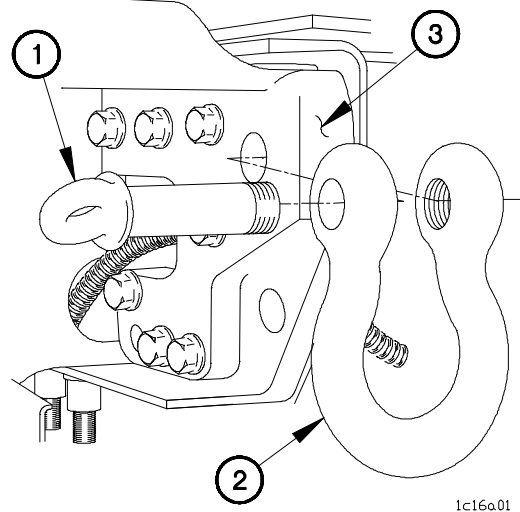
Tools and Special Tools

a. Installation.

NOTE

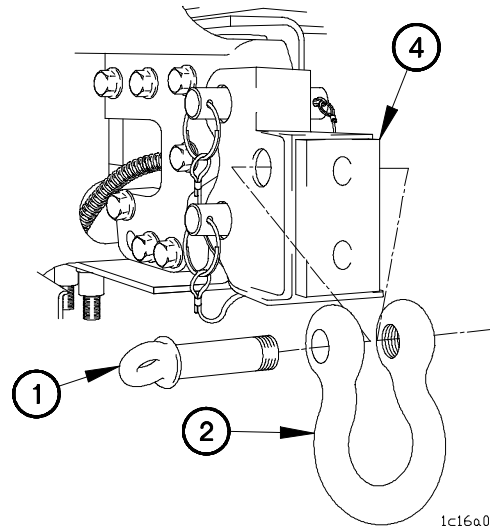
Left and right side are installed the same way. Right side shown.

- (1) Remove shackle pin (1) and shackle (2) from frame rail (3).



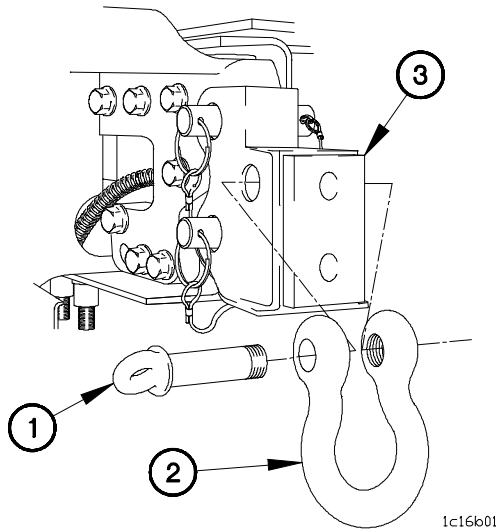
- (2) Install bumperette (4) on frame rail (3) with pin (5).
- (3) Install linch pin (6) in pin (5).
- (4) Install pin (7) in bumperette (4).
- (5) Install linch pin (8) in pin (7).

- (6) Install shackle (2) on bumperette (4) with shackle pin (1).
- (7) Perform steps (1) through (6) on left side.



1c16a03

b. Removal.



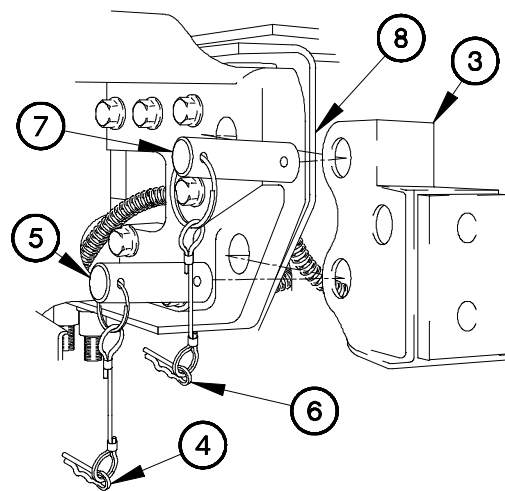
1c16b01

- (2) Remove linch pin (4) from pin (5).
- (3) Remove pin (5) from bumperette (3).
- (4) Remove linch pin (6) from pin (7).
- (5) Remove pin (7) and bumperette (3) from frame rail (8).

NOTE

Left and right side are removed the same way. Right side shown.

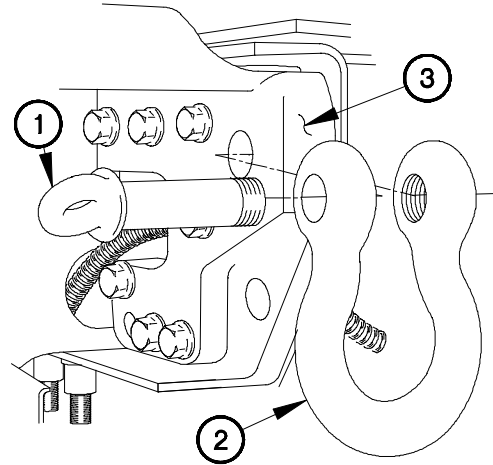
- (1) Remove shackle pin (1) and shackle (2) from bumperette (3).



1c16b02

3-16. BUMPERETTE KIT INSTALLATION/REMOVAL (CONT)

- (6) Install shackle (2) on frame rail (3) with shackle pin (1).
- (7) Perform steps (1) through (6) on right side.



1c16b03

End of Task.

APPENDIX A REFERENCES

A-1. SCOPE

This appendix lists all forms, field manuals, technical manuals, and other publications referenced in this manual. Those publications that should be consulted for additional information about vehicle operations are also listed.

A-2. PUBLICATIONS INDEX

The following index should be consulted frequently for latest changes or revisions and for new publications relating to material covered in this technical manual.

Consolidated Index of Army Publications and Blank Forms DA Pam 25-30

A-3. FORMS

The following forms pertain to this manual. See DA Pam 25-30 for index of blank forms. See DA Pam 738-750, The Army Maintenance Management System (TAMMS), for instructions on the use of maintenance forms pertaining to this material.

Recommended Changes to DA Publications and Blank Forms DA Form 2028-2
Product Quality Deficiency Report SF 368

A-4. OTHER PUBLICATIONS

The following publications contain information pertinent to the LMTV and associated equipment.

a. Safety.

First Aid for Soldiers FM 21-11
Security of Tactical Wheeled Vehicles TB 9-2300-422-20

b. LMTV.

Hand Receipt Covering Contents of Components of End Item
(COEI), Basic Issue Items (BII), and Additional
Authorization List (AAL), for M1078 Series, 2-1/2 Ton,
4x4, Light Medium Tactical Vehicles (LMTV) TM 9-2320-365-10-HR

A-4. OTHER PUBLICATIONS (CONT)

b. LMTV (CONT).

Warranty Program for M1078 Series, 2-1/2 Ton, 4x4,
Light Medium Tactical Vehicle (LMTV) TB 9-2300-365-15

c. General Vehicle Operation.

Vehicle Recovery Operations FM 20-22
Manual for the Wheeled Vehicle Driver FM 21-305
Army Motor Transport Units and Operations FM 55-30
Safety Prevention of Motor Vehicle Accidents AR 385-55

d. General Maintenance and Repair.

Rigging TM 5-575
Use and Care of Hand Tools and Measuring Tools TM 9-243
Materials Used for Cleaning, Preserving, Abrading, and
Cementing Ordnance Materiel and Related Materials
Including Chemicals TM 9-247
Operator's, Unit, Direct Support, and Intermediate General
Support Maintenance Manual for Lead-Acid Storage
Batteries TM 9-6140-200-14
Operator's and Organizational Maintenance Manual for
Radio Sets TM 11-5820-498-12
Operator's Manual, Radio Set, AN/VRC-46 TM 11-5820-401-10-1
Operator's Manual, Radio Set, AN/VRC-90A TM 11-5820-890-10-1
Installation Instructions for Installation Kit, Electronic
Equipment, MK-2715/VRC (NSN 5895-01-421-0812)
(EIC: N/A) to Permit Installation of Radio Set
AN/VRC-89/91/92 Series into M1078, M1080, M1081,
M1083-M1086, M1088-M1094 and M1096
Family of Medium Tactical Vehicles TB 11-5820-890-20-92
Installation Instructions for Installation Kit, Electronic
Equipment, MK-2700/VRC (NSN 5895-01-421-0814)
(EIC: N/A) to Permit Installation of Radio Set
AN/VRC-87/88/90 Series into M1078, M1080, M1081,
M1083-M1086, M1088-M1094 and M1096
Family of Medium Tactical Vehicles TB 11-5820-890-20-101
Cooling Systems: Tactical Vehicles TM 750-254
Army Oil Analysis Program TB 43-0211

e. Cold Weather Operation.

Operation and Maintenance of Ordnance Materiel in Cold
 Weather (0 to -65 °F) FM 9-207
 Basic Cold Weather Manual FM 31-70
 Northern Operations FM 31-71

f. Operation on Unusual Terrain.

Desert Operations (How to Fight) FM 90-3 (HTF)
 Jungle Operations (How to Fight) FM 90-5 (HTF)
 Mountain Operations FM 90-6

g. Decontamination.

Decontamination Operations Facilities & Equipment TB 700-4
 NBC Protection FM 3-4
 NBC Decontamination FM 3-5

h. Maintenance of Special Purpose Kits.

Operator and Organizational Maintenance Manual for
 Chemical Alarm TM 3-6665-225-12
 Operator's and Unit Maintenance Manual Including Repair
 Parts and Special Tools List for Decontaminating
 Apparatus: M13 TM 3-4230-214-12&P
 Operator, Organizational, Direct Support, and General Support
 Maintenance Manual Including Repair Parts and Special Tools
 List for Various Machine Gun Mounts TM 9-1005-245-14
 Operator's, Organizational, Direct Support,
 and General Support Maintenance Manual, Air Conditioner,
 Horizontal Compact, 18,000 BTU/HR, 208 Volts, 3 Phase,
 50/60 Hertz, Model F18H-3S (4120-01-165-1125) TM 5-4120-384-14
 Operator's, Unit, and Intermediate
 Maintenance Manual, Heater, Space, Multifuel with Blower,
 60,000 BTU/HR, 120V, UH-68G (4520-01-203-4410) TM 5-4520-253-13

j. General.

Principles of Automotive Vehicles TM 9-8000
 Procedures for Destruction of Tank-Automotive Equipment to
 Prevent Enemy Use (US Army Tank-Automotive Command) TM 750-244-6
 Route Reconnaissance and Classification FM 5-36

TM 9-2320-365-10

k. Land, Sea, and Air Shipment.

Airdrop of Supplies and Equipment: Rigging 2-1/2 Ton Trucks FM 10-520
Marine Terminal Lifting Guidance MTMCTEA Pam 56-1
Multiservice Helicopter External Air Transport: Basic
Operations and Equipment FM 55-450-3
Multiservice Helicopter External Air Transport: Dual-Point
Load Rigging Procedures FM 55-450-5
Multiservice Helicopter External Air Transport: Single-Point
Load Rigging Procedures FM 55-450-4
Standard Characteristics (Dimensions, Weight, and Cube) for
Transportability of Military Vehicles and Other
Outsize/Overweight Equipment (in TOE Line Sequence) TB 55-46-1
Tiedown Handbook for Rail Movements MTMCTEA Pam 55-19
Tiedown Handbook for Truck Movements MTMCTEA Ref 92-55-20

APPENDIX B COMPONENTS OF END ITEM (COEI) AND BASIC ISSUE ITEMS (BII) LISTS

Section I. INTRODUCTION

B-1. SCOPE

This appendix lists components of the end item and basic issue items for the LMTV to help you inventory the items for safe and efficient operation of the equipment.

B-2. GENERAL

The Components of End Item (COEI) and Basic Issue Items (BII) lists are divided into the following sections:

a. Section II, Components of End Item. This listing is for information purposes only, and is not authority to requisition replacements. These items are part of the LMTV, but they are not to be removed and separately packaged for transportation or shipment. As part of the end item, these items must be with the end item whenever it is issued or transferred between property accounts. Illustrations are furnished to help you find and identify the items.

b. Section III, Basic Issue Items. These essential items are required to place the LMTV in operation, operate it, and to do emergency repairs. Although shipped separately packaged, BII must be with the LMTV during operation and when it is transferred between property accounts. Listing these items is your authority to request/requisition them for replacement based on authorization of the end item by the TOE/MTOE. Illustrations are furnished to help you find and identify the items.

B-3. EXPLANATION OF COLUMNS

The following provides an explanation of columns found in the tabular listings:

- a. Column (1), Illus Number.** Gives you the number of the item illustrated.
- b. Column (2), National Stock Number.** Identifies the stock number of the item to be used for requisitioning purposes.

B-3. EXPLANATION OF COLUMNS (CONT)

c. Column (3), Description and Usable On Code. Identifies the Federal item name (in capital letters) followed by a minimum description when needed. The last line below the description is the Commercial and Government Entity Code (CAGEC) (in parentheses) and the part number.

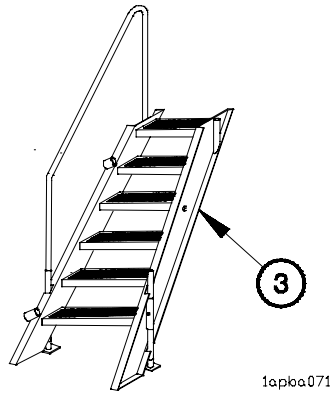
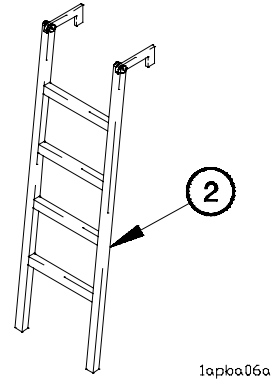
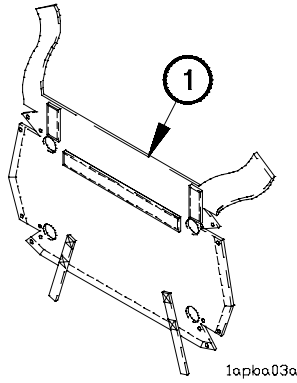
If the item you need is not the same for different models of the equipment, a Usable On Code will appear on the right side of the description column on the same line as the part number. These codes are identified below:

<u>CODE</u>	<u>USED ON</u>
LAB	M1078
LWB	M1078 w/11K Self-Recovery Winch
LAD	M1079
LWD	M1079 w/11K Self-Recovery Winch
LAA	M1080
LAC	M1081
LWC	M1081 w/11K Self-Recovery Winch

d. Column (4), U/M (unit of issue). Indicates how the item is issued for the National Stock Number shown in column two.

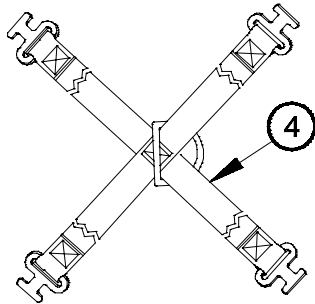
e. Column (5), Qty Reqd. Indicates the quantity required.

Section II. COMPONENTS OF END ITEM

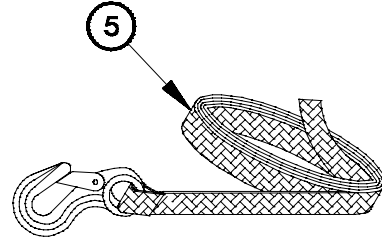


(1) Illus Number	(2) National Stock Number	(3) Description CAGEC and Part Number	Usable On Code	(4) U/I	(5) Qty Reqd
1	2540-01-453-6945	COVER, RADIATOR, COLD WEATHER (19207) 12421395		EA	1
2	2540-01-394-9681	LADDER, BOARDING (19207) 12418950	LAB,LAC, LWB,LWC	EA	1
3		LADDER, BOARDING (19207) 12421355	LAD,LWD	EA	1

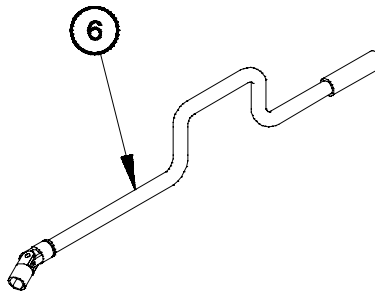
Section II. COMPONENTS OF END ITEM (CONT)



1apba09a



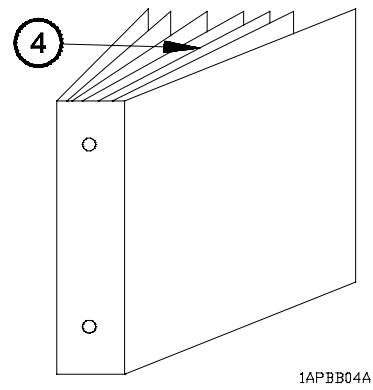
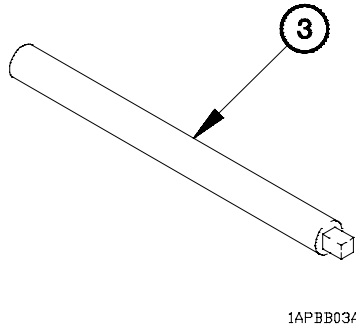
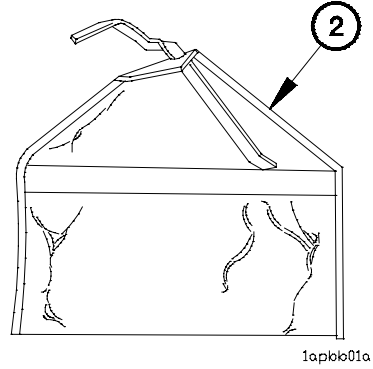
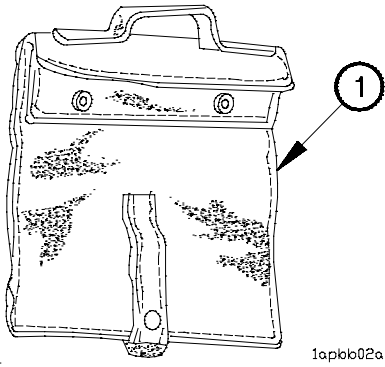
1apba10a



1apba13a

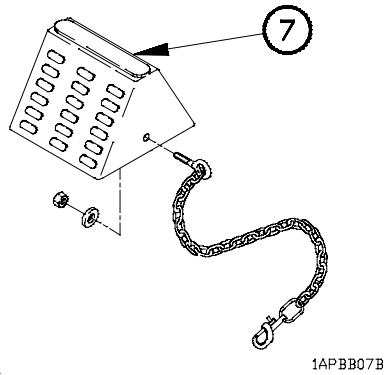
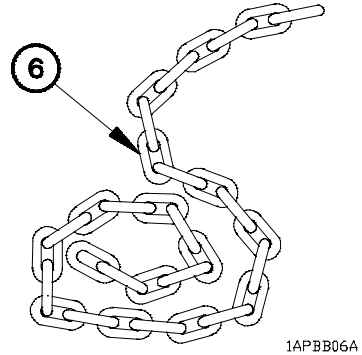
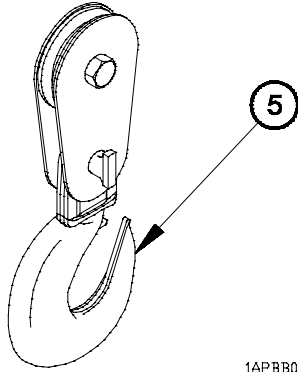
(1) Illus Number	(2) National Stock Number	(3) Description CAGEC and Part Number	Usable On Code	(4) U/I	(5) Qty Reqd
4	3940-01-469-9939	SLING SET, MULTIPLE LEG (19207) 12419197	LAC,LWC	EA	1
5	5340-01-433-4157	STRAP WEBBING (19207) 12421187	LAC,LWC	EA	1
6	5120-01-433-4829	WRENCH ASSEMBLY, SPEED HANDLE, W/UNIVERSAL SOCKET (0FW39) TV950065	LAC,LWC	EA	1

Section III. BASIC ISSUE ITEMS



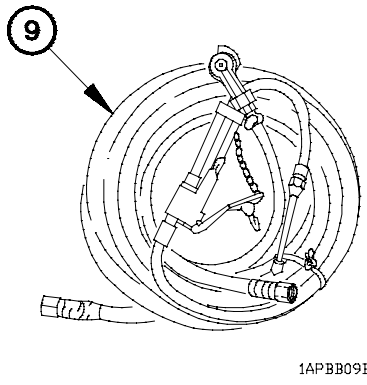
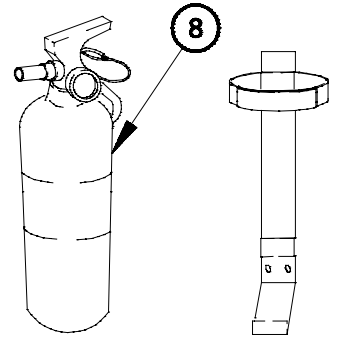
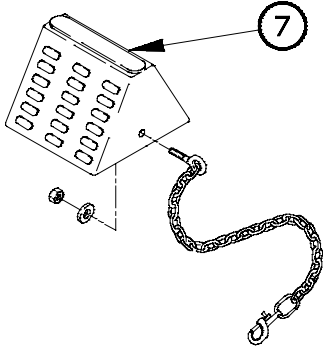
(1) Illus Number	(2) National Stock Number	(3) Description CAGEC and Part Number	Usable On Code	(4) U/I	(5) Qty Reqd
1	2540-00-670-2459	BAG ASSEMBLY, PAMPHLET (19207) 7961712		EA	1
2	5140-00-772-4142	BAG, TOOL (19207) 7724142		EA	1
3	5120-00-243-2419	BAR, SOCKET WRENCH HANDLE (19207) 6196147		EA	1
4	7510-00-889-3494	BINDER, LOOSE LEAF (19207) 11677003		EA	1

Section III. BASIC ISSUE ITEMS (CONT)



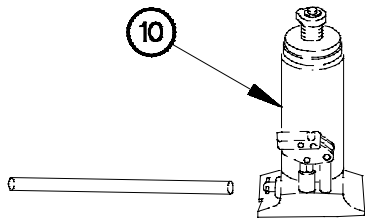
(1) Illus Number	(2) National Stock Number	(3) Description CAGEC and Part Number	Usable On Code	(4) U/I	(5) Qty Reqd
5	3940-01-447-4095	BLOCK, TACKLE (75535) M8011971	LWB,LWC	EA	1
6	4010-01-389-1657	CHAIN, WELDED (0FW39) 12418052		EA	1
7	2540-00-678-3469	CHOCK, WHEEL (58536) A-A-54275-1		EA	2
	5306-00-108-0943	BOLT (96906) MS35751-65		EA	1

Section III. BASIC ISSUE ITEMS (CONT)

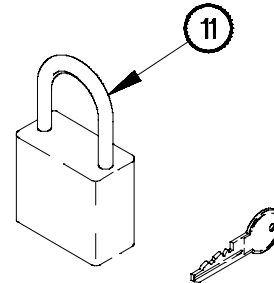


(1) Illus Number	(2) National Stock Number	(3) Description CAGEC and Part Number	(4) Usable On U/I Code	(5) Qty Reqd
7 (cont)	5310-00-087-7493	WASHER (96906) MS27183-13	EA	1
	5310-00-880-7744	NUT (96906) MS51967-5	EA	1
	5340-01-243-9656	SNAP HOOK (81349) M43770/6-MIXEE1	EA	1
8	4210-01-149-1356	EXTINGUISHER, FIRE (19207) 12255633-1	EA	1
9	4910-01-038-2820	INFLATOR-GAGE, TIRE W/HOSE (19207) 11677140-5	EA	1

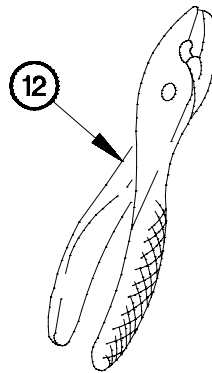
Section III. BASIC ISSUE ITEMS (CONT)



1APBB10B



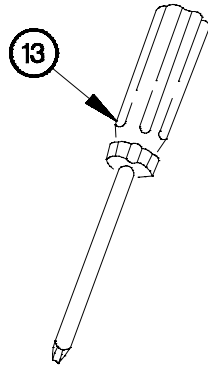
1APBB11B



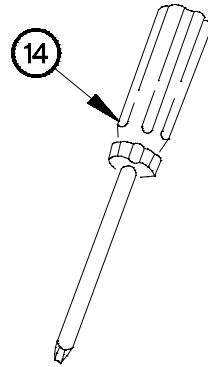
1APBB12B

(1) Illus Number	(2) National Stock Number	(3) Description CAGEC and Part Number	Usable On Code	(4) U/I	(5) Qty Reqd
10	5120-01-374-0532	JACK, HYDRAULIC, HAND OPERATED (0E3L5) D-51013		EA	1
11	5340-00-468-5390	PADLOCK SET (22107) 5200GLKAZ		EA	1
12	5120-00-223-7397	PLIERS, SLIP JOINT, 8 IN. (56161) 10510983		EA	1

Section III. BASIC ISSUE ITEMS (CONT)



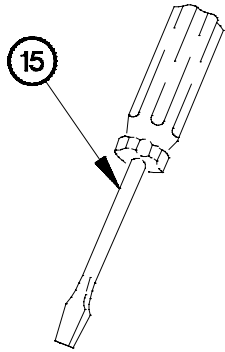
1APBB13B



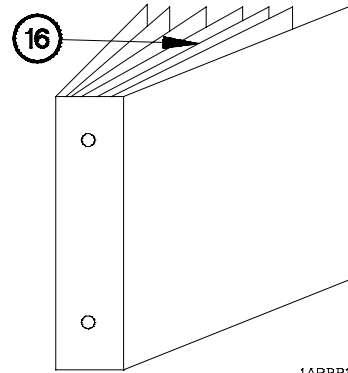
1APBB14B

(1) Illus Number	(2) National Stock Number	(3) Description CAGEC and Part Number	(4) Usable On U/I Code	(5) Qty Reqd
13	5120-00-234-8912	SCREWDRIVER, CROSSTIP (19207) 11655777-9	EA	1
14	5120-00-234-8913	SCREWDRIVER, CROSSTIP (19207) 11655777-12	EA	1

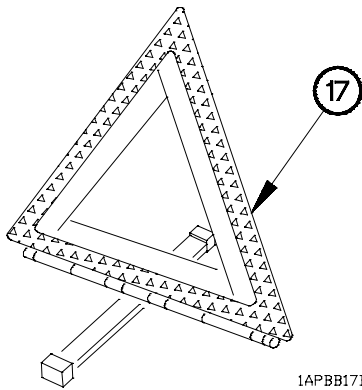
Section III. BASIC ISSUE ITEMS (CONT)



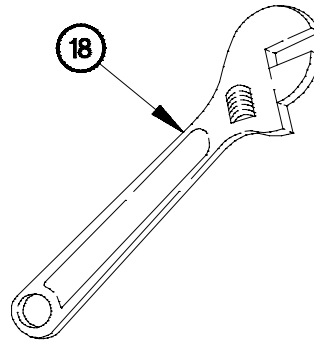
1APBB15B



1APBB16B



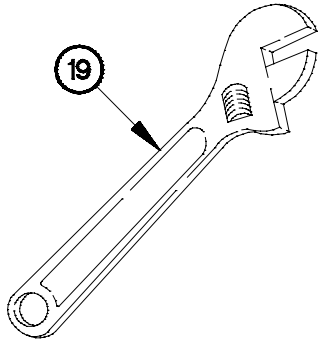
1APBB17B



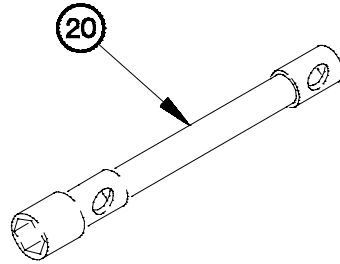
1APBB18B

(1) Illus Number	(2) National Stock Number	(3) Description CAGEC and Part Number	Usable On Code	(4) U/I	(5) Qty Reqd
15	5120-00-237-6985	SCREWDRIVER, FLATTIP (56161) 10510988		EA	1
16		TECHNICAL MANUAL, OPERATOR'S INSTRUCTIONS, M1078 SERIES, 2 1/2 TON, TM 9-2320-365-10		EA	1
17	9905-00-148-9546	WARNING DEVICE KIT (19207) 11669000		EA	3
18	5120-00-240-5328	WRENCH, ADJUSTABLE, 8 In. (19207) 11655778-3		EA	1

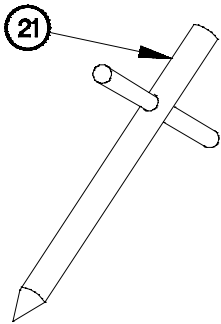
Section III. BASIC ISSUE ITEMS (CONT)



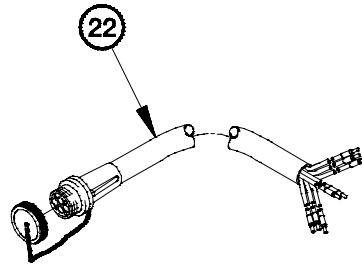
1APBB19B



1APBB20B



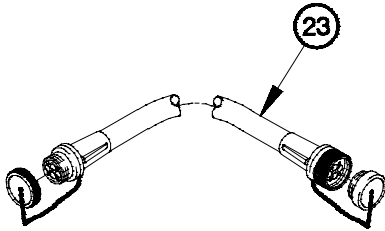
1APBB21B



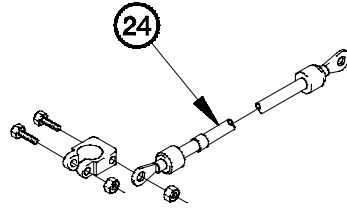
1APBB22B

(1) Illus Number	(2) National Stock Number	(3) Description CAGEC and Part Number	Usable On Code	(4) U/I	(5) Qty Reqd
19	5120-00-264-3796	WRENCH, ADJUSTABLE, 12 In. (19207) 11655778-5		EA	1
20	5120-00-316-9217	WRENCH, SOCKET (19207) 11677000-3		EA	1
21	2510-00-790-2296	ROD, GROUND, 3/4 IN. DIAMETER (19207) 8380403	LAD, LWD	EA	1
22	5995-01-190-5573	CABLE ASSEMBLY, 10 FT (80063) SC-D-883964GRP9-1	LAD, LWD	EA	1

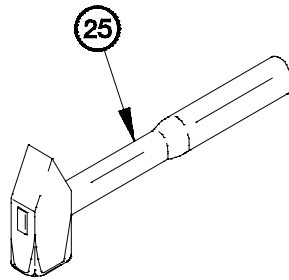
Section III. BASIC ISSUE ITEMS (CONT)



1APBB23B



1APBB24B



1APBB25B

(1) Illus Number	(2) National Stock Number	(3) Description CAGEC and Part Number	Usable On Code	(4) U/I	(5) Qty Reqd
23	5995-01-134-3159	CABLE ASSEMBLY, POWER, ELECTRICAL (80063) SC-D-883963-G9-3	LAD,LWD	EA	1
24	6150-01-460-9581	CABLE ASSEMBLY, SPECIAL PURPOSE, ELECTRICAL (19207) 12421527	LAD,LWD	EA	1
25	5120-00-900-6103	HAMMER, HAND (58536) A-A-1292	LAD,LWD	EA	1

APPENDIX C ADDITIONAL AUTHORIZATION LIST (AAL)

Section I. INTRODUCTION

C-1. SCOPE

This appendix lists additional items you are authorized for support of the vehicle.

C-2. GENERAL

This list identifies items that do not have to accompany the LMTV and that do not have to be turned in with it. These items are all authorized to you by Common Tables of Allowance (CTA), Modification Table of Organization and Equipment (MTOE), Tables of Distribution and Allowances (TDA), or Joint Table of Allowance (JTA).

C-3. EXPLANATION OF LISTING

National Stock Numbers, description, and quantities are provided to help you identify and request the additional items you require to support this equipment. If the item required differs for different models of this equipment, see the "Usable On Code" column for the applicable model or models. Codes used are:

<u>USABLE ON CODE</u>	<u>MODEL</u>
LAB	M1078
LWB	M1078 w/11K Self-Recovery Winch
LAD	M1079
LWD	M1079 w/11K Self-Recovery Winch
LAA	M1080
LAC	M1081
LWC	M1081 w/11K Self-Recovery Winch

Section II. ADDITIONAL AUTHORIZATION LIST

(1) National Stock Number	(2) Description CAGEC & Part Number	Usable On Code	(3) U/I	(4) Qty Auth
4010-01-470-2864	ADAPTER KIT, LADDER, S280 SHELTER (19207) 57K1950	LAB,LAC, LWB,LWC	KT	1

Section II. ADDITIONAL AUTHORIZATION LIST (CONT)

(1) National Stock Number	(2) Description CAGEC & Part Number	Usable On Code	(3) U/I	(4) Qty Auth
6665-00-859-2215	ALARM UNIT, CHEMICAL AGENT AUTOMATIC ALARM (81361) D5-15-4826		EA	1
5110-00-293-2336	AX, SINGLE BIT (19207) 6150925		EA	1
4010-00-473-6166	CARGO RING REPLACEMENT KIT 57K2017	LAB, LWB LAC, LWC	KT	1
2540-01-483-2930	CHAIN, 16 FT (19207) 7077063		EA	1
4030-01-477-0524	CHAIN, PNEUMATIC TIRE, TRUCK, SINGLE TIRE TYPE (4N506) A08SV (OPTIONAL P/N 2540-01-492-2989 (4N506) CLO7S)		EA	1
5120-01-416-8568	CLAMP, LINE, SLIDING (098P0) NEI PR054-001-B		EA	1
6665-00-859-2201	COMBINATION TOOL, HAND (0T9K4) 595		EA	1
8415-00-634-4658	DETECTOR UNIT, CHEMICAL AGENT AUTOMATIC ALARM (81361) D5-15-4400		EA	1
5120-00-288-6574	GLOVES, LEATHER (90142) 37G2940		EA	1
4910-01-396-5044	HANDLE, MATTOCK-PICK (19207) 11677021		EA	1
2540-01-495-5929	JACK KIT, BUMPERETTE (19207) 57K3395	LBB,LXB, LBD, LXD LBA	KT	1
2540-01-385-9462	KIT, CONVEX MIRROR (19207) 57K1995		KT	1
2540-01-437-1463	KIT, RH CONVEX MIRROR (19207) 57K1995		KT	1
2540-01-385-9462	KIT, COVER, SOFT TOP, GREEN CAMO (19207) 57K1898	LAB,LAC, LWB,LWC	KT	1
2540-01-437-1463	KIT, COVER, SOFT TOP, TAN (19207) 57K1925	LAB,LAC, LWB,LWC	KT	1
6545-00-922-1200	KIT, CRANE ADAPTER (19207) 57K4206	LWB,LWC	KT	1
	KIT, FIRST AID (19207) 11677011		EA	1
	KIT, RESILIENT MOUNT 57K2003		KT	1

Section II. ADDITIONAL AUTHORIZATION LIST (CONT)

(1) National Stock Number	(2) Description CAGEC & Part Number	Usable On Code	(3) U/I	(4) Qty Auth
2540-01-489-5928	KIT, RIM COVER 57K1996		KT	1
3990-01-444-1013	KIT, TIE DOWN, S280 SHELTER (19207) 57K1949	LAB,LAC, LWB,LWC	KT	1
3990-01-449-8358	KIT, TIEDOWN, S280 SHELTER (19207) 57K1952	LAB, LWB LAC, LWC	KT	1
3990-01-494-2285	KIT, MODIFICATION, S280 SHELTER TIEDOWN KIT – LMTV CARGO OR LWB CARGO (19207) 57K4448	LAB, LWB LAC, LWC	KT	1
5999-01-491-9472	KIT, DIGITIZATION RACK/STORAGE (19207) 57K2012	LAB, LWB, LAD LWD, LAA	KT	1
5999-01-491-9221	KIT, DIGITIZATION ELECTRIC (19207) 57K2013	LAB, LWB, LAD LWD, LAA	KT	1
3990-01-494-6071	KIT, TIEDOWN, S280 SHELTER (MODIFIED) (19207) 57K4449	LAB, LWB LAC, LWC	KT	1
2540-01-381-5860	KIT, TROOP SEATS (19207) 57K1893	LAB,LAC, LWB,LWC	KT	1
3810-01-368-7723	LIGHT MATERIAL HANDLING CRANE KIT (12361) 1-195-0-00516	LAB,LAC, LWB,LWC	KT	1
1005-01-381-5431	MACHINE GUN RING MOUNT KIT (19207) 57K1224		KT	1
5120-00-243-2395	MATTOCK (19207) 11677022		EA	1
3940-01-449-2385	NET, DRAFT COVER (098P0) B9154-090-168-2R-14C		EA	1
4130-01-456-0718	PARTS KIT, AIR CONDITIONING (19207) 57K1947	LAD,LWD	KT	1
115-01-432-2684	PARTS KIT, ELECTRICAL GENERATOR, 200 AMP (19207) 57K1912		KT	1
2990-01-456-0719	PARTS KIT, HEATER (19207) 57K1948	LAD,LWD	KT	1
6220-01-423-2337	PARTS KIT, VEHICULAR LIGHTING (19207) 57K1220		KT	1

Section II. ADDITIONAL AUTHORIZATION LIST (CONT)

(1) National Stock Number	(2) Description CAGEC & Part Number	Usable On Code	(3) U/I	(4) Qty Auth
4030-01-477-0508	SNAP LINK, CARGO (098P0) NEI 40WGB		EA	1
5340-01-477-3850	SNAP HOOK (098P0) NEI 66C1705HUMJ		EA	1
2540-01-496-4442	REPAIR KIT, SOFT TOP (19207) 57K2010		KT	1
5120-00-228-9518	WRENCH, BOX AND OPEN END, COMBINATION (05506) 1174	LAD,LWD	EA	1

Section II. EXPENDABLE AND DURABLE ITEMS LIST (CONT)

**APPENDIX D
EXPENDABLE AND DURABLE ITEMS LIST**

Section I. INTRODUCTION

D-1. SCOPE

This appendix lists all expendable and durable items that you will need to operate and maintain the LMTV. This listing is for information only and is not authority to requisition the listed items. These items are authorized to you by CTA 50-970 Expendable/Durable Items (except medical, class V, repair parts, and heraldic items), or CTA 8-100, Army Medical Department Expendable/Durable Items.

D-2. EXPLANATION OF COLUMNS

- a. **Column (1). Item Number.** This number is assigned to the entry in the listing and is referenced in the narrative instructions to identify the item (e.g. "Use cleaning compound, item 5, Appendix D.").
- b. **Column (2). Level.** This column identifies the lowest level of maintenance that requires the item.
- c. **Column (3). National Stock Number.** This is the national stock number assigned to the item which you can use to requisition it.
- d. **Column (4). Item Name, Description, Commercial and Government Entity Code (CAGEC), and Part Number.** This provides the other information you need to identify the item.
- e. **Column (5). Unit of Measure.** This code shows the physical measurement or count of an item, such as gallon, dozen, gross, etc.

Section II. EXPENDABLE AND DURABLE ITEMS LIST

(1) Item Number	(2) Level	(3) National Stock Number	(4) Item Name, Description, CAGEC, Part Number	(5) U/M
1	C	6850-00-174-1806	Antifreeze, (MIL-A-11755)(81349) 55 gal drum	dr
2	C	6850-01-441-3218 6850-01-441-3221 6850-01-441-3257	Antifreeze, Multi-Engine Type A-A-52624A (58536) Type I (Green) 1 gal Type I (Green) 5 gal Type II (Purple) 5 gal	 gal co co

Section II. EXPENDABLE AND DURABLE ITEMS LIST (CONT)

Section II. EXPENDABLE AND DURABLE ITEMS LIST

(1) Item Number	(2) Level	(3) National Stock Number	(4) Item Name, Description, CAGEC, Part Number	(5) U/M
3	C	6850-00-926-2275	Cleaning Compound, Windshield (O-C-1901) (81349) 1 pint	pt
	C	9150-00-664-0047	Damping Fluid (VV-D-1078) (81348) 1 lb can	lb
	C	8415-00-641-4601	Gloves, Rubber (ZZ-G-381) (81348) 1 pr	pr
4	C	4240-00-052-3776	Goggles, Industrial (A-A-1110) (58536) 1 pr	pr
	C		Grease, Automotive and Artillery (GAA) (MIL-G-10924) (81349) 2-1/4 oz tube	
		9150-01-197-7688 9150-01-197-7693 9150-01-197-7692	14 oz cartridge 35 lb can	tu ca cn
5	C		Hydraulic Fluid, Petroleum Base (MIL-H-5606) (81349)	
		9150-00-252-6383	1 qt can	qt
		9150-00-223-4134	1 gal can	gal
		9150-00-082-7524 9150-00-265-9408	10 gal drum 55 gal drum	dr dr
7	C		Oil, Fuel, Diesel, DF-1, Winter (VV-F-800) (91348)	
		9140-00-286-5286	Bulk	gal
		9140-00-286-5288 9140-00-286-5289	55 gal drum, 16 gage 55 gal drum, 18 gage	dr dr
8	C		Oil, Fuel, Diesel, DF-2, Regular VV-F-800) (81348)	
		9140-00-286-5294	Bulk	gal
		9140-00-286-5296 9140-00-286-5297	55 gal drum, 16 gage 55 gal drum, 18 gage	dr dr
9	C		Oil, Lubricating Gear, GO 75W (MIL-L-2105C)	
		9150-01-035-5390 9150-01-035-5391	1 qt can 5 gal drum	qt gal

Section II. EXPENDABLE AND DURABLE ITEMS LIST (CONT)

Section II. EXPENDABLE AND DURABLE ITEMS LIST

(1) Item Number	(2) Level	(3) National Stock Number	(4) Item Name, Description, CAGEC, Part Number	(5) U/M
10	C	9150-01-035-5392	Oil, Lubricating, Gear, GO 80W-90 (MIL-L-2105C) 1 qt can	qt
		9150-01-035-5393	5 gal can	cn
		9150-01-035-5394	55 gal drum	dr
11	C	9150-00-183-7807	Oil, Lubricating, OE/HDO 10 (MIL-L-2104) bulk	gal
		9150-00-186-6668	5 gal can	cn
		9150-00-191-2772	55 gal drum, 16 gage	dr
12	C	9150-00-189-6727	Oil, Lubricating, OE/HDO 10W (MIL-L-2104) 1 qt can	qt
13	C	9150-01-152-4117	Oil, Lubricating, OE/HDO 15W- 40 (MIL-M-2104) 1 qt can	qt
		9150-01-152-4118	5 gal can	cn
		9150-01-152-4119	55 gal drum	dr
14	C	9150-00-183-7808	Oil, Lubricating, OE/HDO 30 (SAE 30) (MIL-L-2104) bulk	gal
		9150-00-186-6681	1 qt can	qt
		9150-00-188-9858	5 gal can	cn
		9150-00-189-6729	55 gal drum, 18 gage	dr
15	C	9150-00-405-2987	Oil, Lubricating, OE/HDO 40 (MIL-L-2104) bulk	gal
		9150-00-189-6730	1 qt can	qt
		9150-00-188-9862	5 gal can	cn
16	C	9150-00-402-4478	Oil, Lubricating, OE/HD (MIL-L-46167), Arctic 1 qt can	qt
		9150-00-402-2372	5 gal can	cn
		9150-00-491-7197	55 gal drum	dr
17	C	7920-00-205-1711	Rag, Wiping, Cotton and Cotton-Synthetic	lb

Section II. EXPENDABLE AND DURABLE ITEMS LIST (CONT)

Section II. EXPENDABLE AND DURABLE ITEMS LIST

(1) Item Number	(2) Level	(3) National Stock Number	(4) Item Name, Description, CAGEC, Part Number	(5) U/M
18	C	7930-00-634-3935	Soap, Laundry (54748) 539-200LBCHIPS 200 lb drum	dr
19	C	6850-00-281-1985 6850-00-664-5685	Solvent, Dry Cleaning SD (P-D- 680) 1 gal can 1 qt can	gal qt

APPENDIX E STOWAGE AND DECAL/DATA PLATE GUIDE

Section I. INTRODUCTION

E-1. SCOPE

This appendix shows the location for stowage of equipment and material required to be carried on M1078 series vehicles and location for data plates, decals, and stencils that are required to be placed on the vehicle.

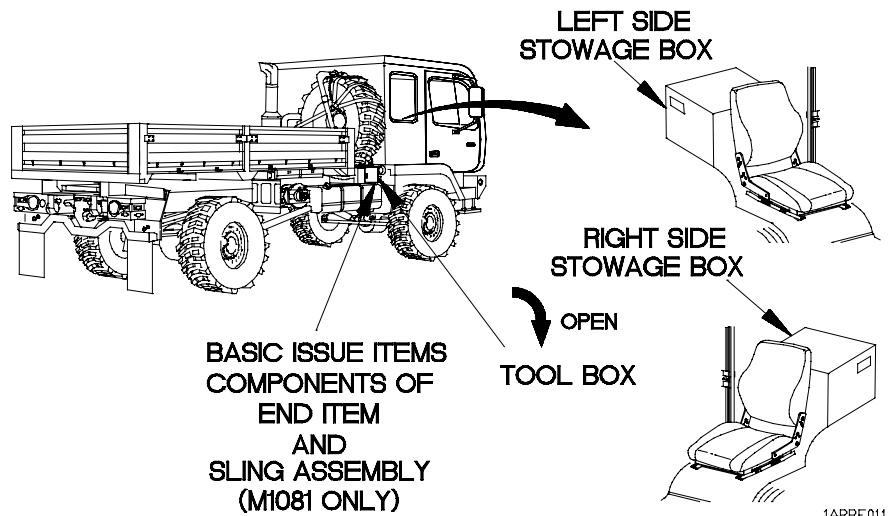
Section II. STOWAGE LOCATION/DECAL/STENCIL GUIDE

E-2. GENERAL

The equipment stowage locator is designed to help inventory items required for safe and efficient operation. The equipment locator is representative of BII and applicable AAL stowage on all M1078 series vehicles.

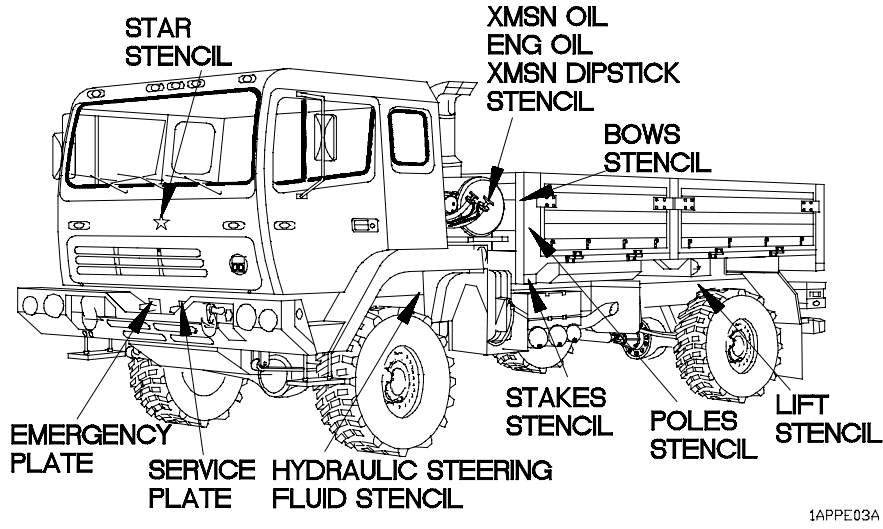
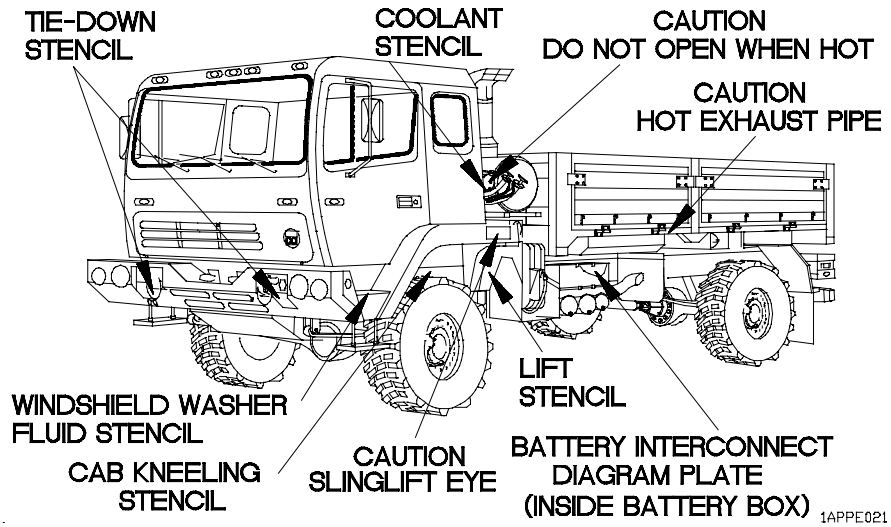
E-3. STOWAGE LOCATIONS

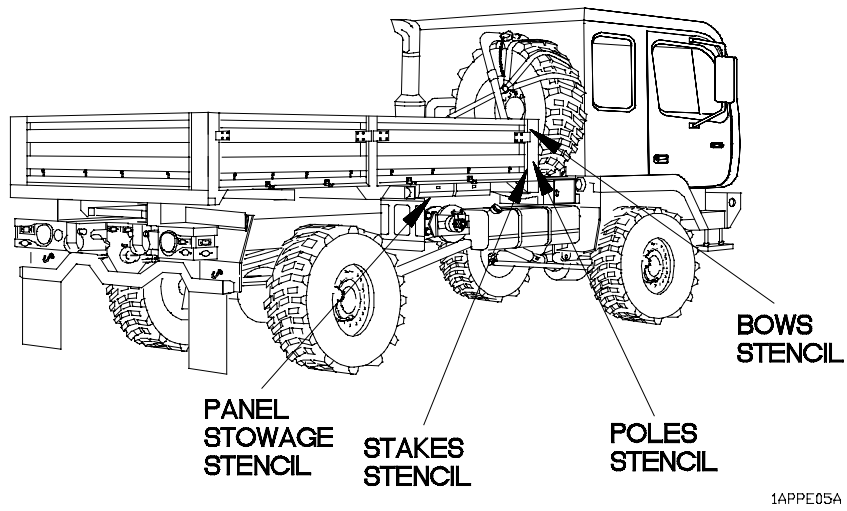
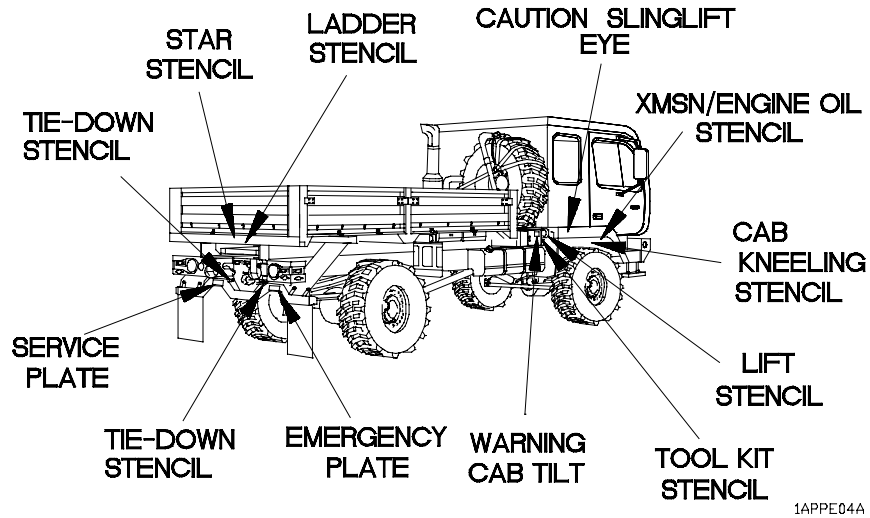
Stowage Locations, All Vehicles.



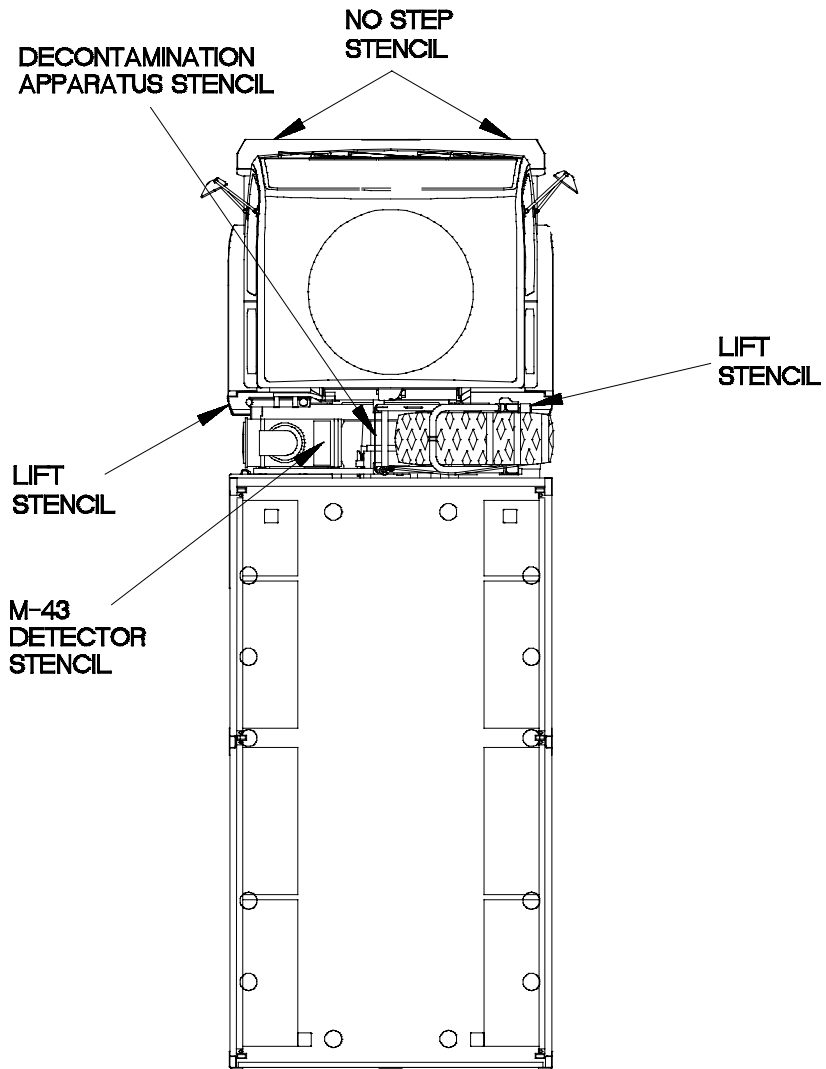
E-4. SIGN GUIDE

a. Decals/Stencils, All Vehicles.

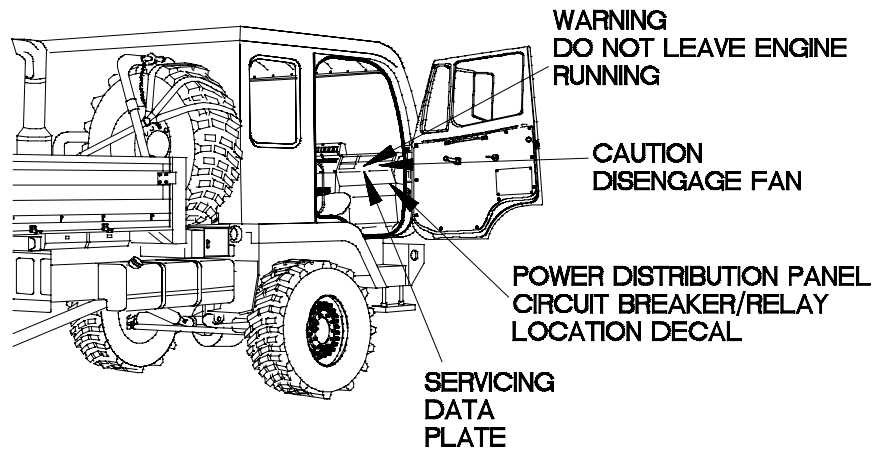
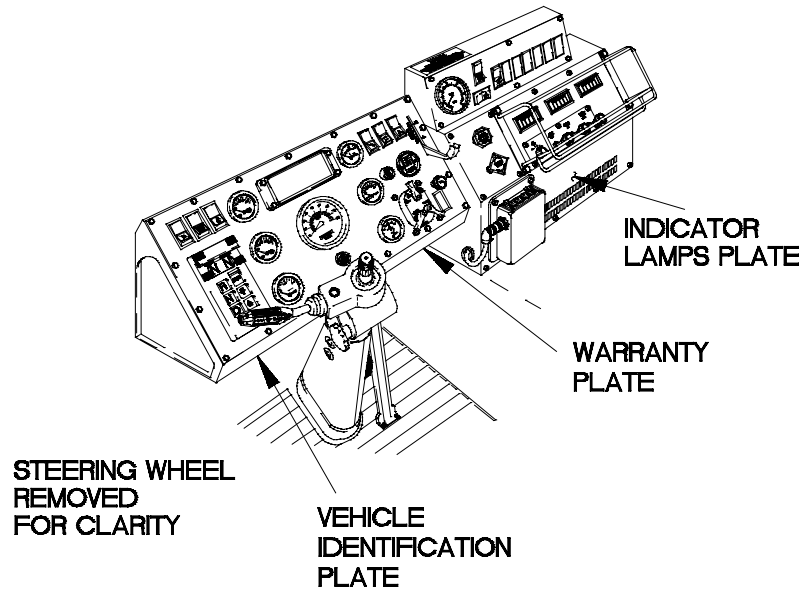




E-4. SIGN GUIDE (CONT)



1APPE06A



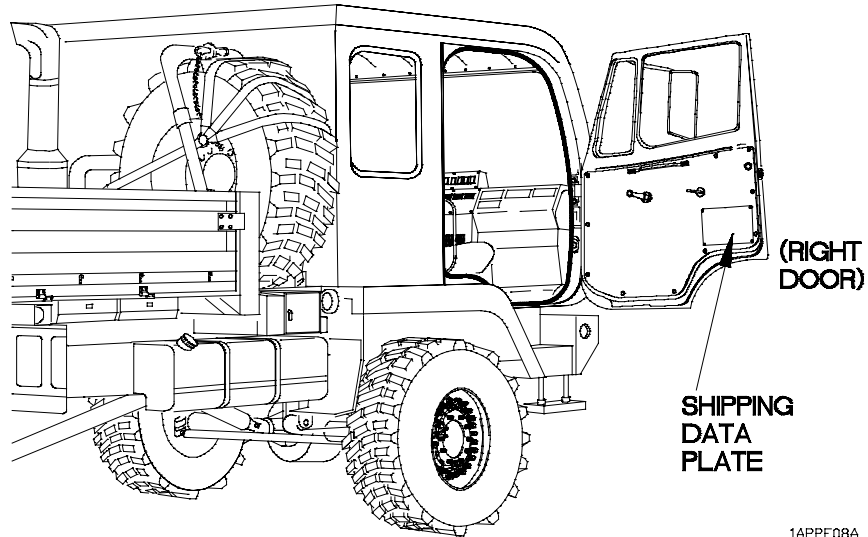
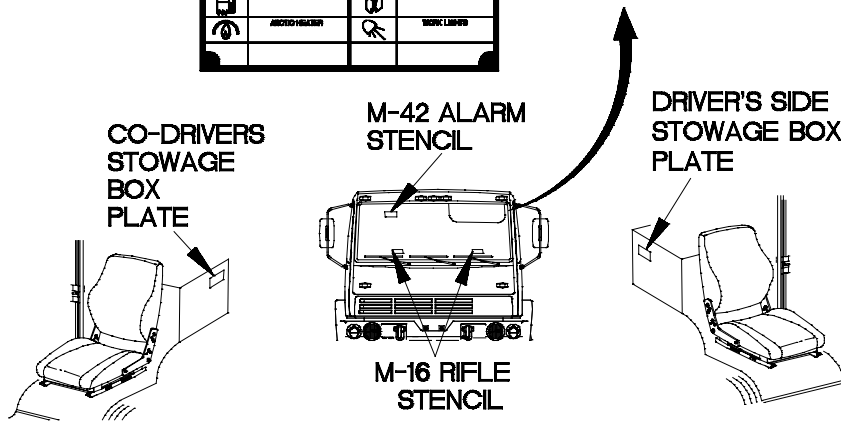
1APPE07B

E-4. SIGN GUIDE (CONT)

VEHICLES SN 3092 AND HIGHER

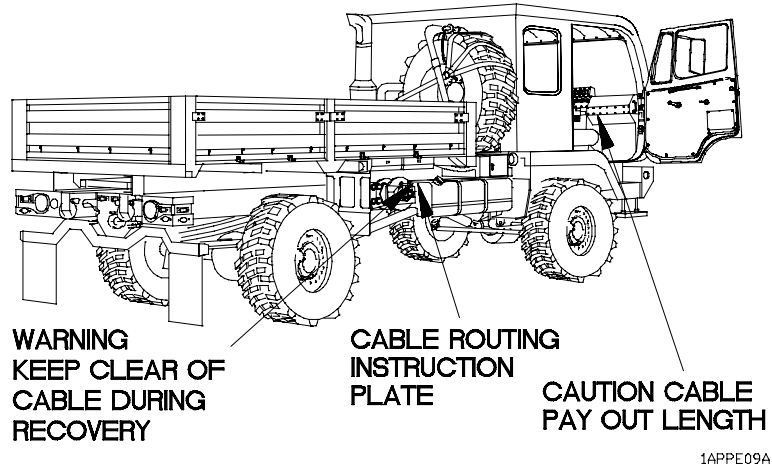
CONTROLS			
	ENGINE PREHEAT		PRIORITY WARNING BEACON
	WRECKED VEHICLE		INDICATOR/PRE-OP
	HORN		FORWARD WARNING
	WRECKED VEHICLE		FUSION
	RIPPER BLADE		WORK CONTROL
	FUEL PREHEAT		PFD DISABLED
	AUTO/MANUAL		WORK LIGHTS

INDICATOR LAMPS			
	LOW OIL PRESSURE WARNING		HIGH ENGINE TEMPERATURE WARNING
	HIGH BEAM ON		PFD DISABLED
	TURN SIGNAL		INDICATOR FAN OFF

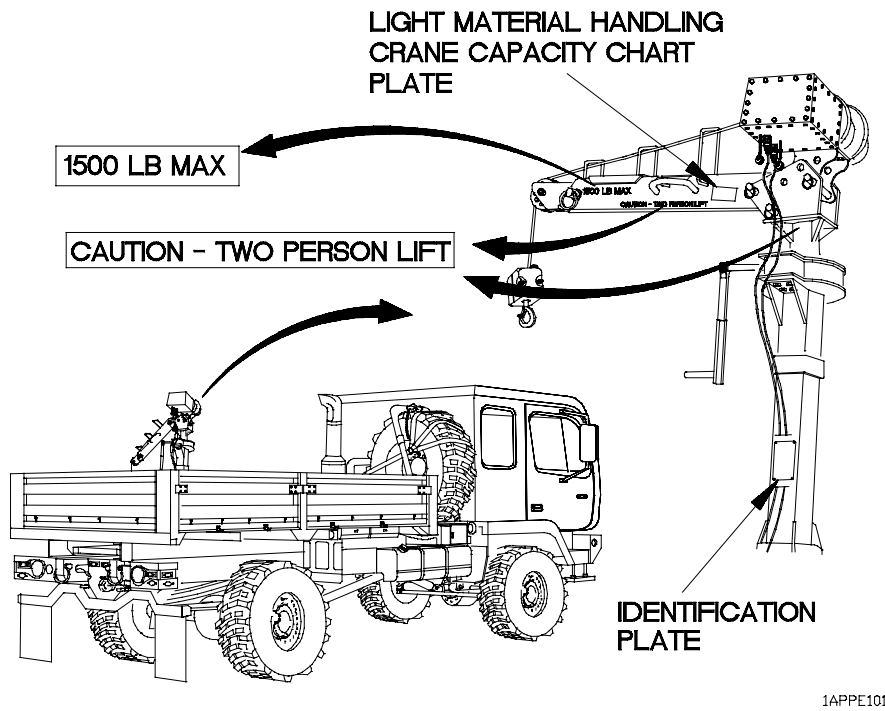


1APPE08A

b. Decal/Data Plate Guide, Vehicles with 11K Self-Recovery (SRW).



c. Decal/Data Plate Guide, Vehicles with Light Material Handling Crane (LMHC).



APPENDIX F LUBRICATION ORDER AND SERVICES

Section I. INTRODUCTION

F-1. GENERAL

This appendix gives lubrication/service requirements for the vehicle which are the responsibility of the Operator/Crew.

- a. Adherence.** Intervals (on-condition or hard time) and the related man-hour times are based on normal operation. The man-hour time specified is the time needed to do all the services prescribed for a particular interval. On-condition (OC) oil sample intervals shall be applied unless changed by the Army Oil Analysis Program (AOAP) laboratory. Change the hard time interval if lubricants are contaminated or if operating the equipment under adverse operating conditions, including longer-than-usual operating hours. The calendar interval may be extended during periods of low activity. If extended, adequate preservation precautions must be taken. Hard time intervals will be applied in the event AOAP laboratory support is not available. Hard time intervals must be applied during the warranty period.

Intervals shown in this lubrication order and services are based on mileage/calendar times. The lubrication/services for the vehicle is to be performed at whichever interval occurs first.

WARNING

- **Dry Cleaning Solvent (P-D-680) is TOXIC and flammable. Wear protective goggles and gloves; use only in well-ventilated area; avoid contact with skin, eyes, and clothes, and do not breath vapors. Keep away from heat or flame. Never smoke when using solvent; the flashpoint for Type I Dry Cleaning Solvent is 100°F (38°C) and for Type II is 138°F (50°C). Failure to comply may result in serious injury or death to personnel.**
 - **If personnel become dizzy while using cleaning solvent, immediately get fresh air and medical help. If solvent contacts skin or clothes, flush with cold water. If solvent contacts eyes, immediately flush eyes with water and get medical attention. Failure to comply may result in serious injury or death to personnel.**
- b. Cleaning Fittings Before Lubrication.** Clean parts with Dry Cleaning Solvent (SD P-D-680) or equivalent. Dry before lubricating. Dashed arrows indicate lubrication on both sides of the equipment.
- c. Lubrication After Forging.** If a forging operation occurs, lubricate all fittings below forging depth and check submerged gear boxes for presence of water.

F-1. GENERAL (CONT)

- d. **Lubrication After High-Pressure Washing.** After a thorough washing, lubricate all grease fittings and oil can points outside and underneath vehicle.
- e. **Lubrication Local Views.** A reference to the appropriate local view is given after most lubrication/service entries. Local views begin on page F-7.

F-2. CORROSION CONTROL

Refer to para 1-3 for appropriate corrosion control procedures.

F-3. AOAP SAMPLING INTERVAL

Engine/transmission oil must be sampled every 90 days as prescribed by DA Pam 738-750. Hydraulic fluids must be sampled annually as prescribed by DA Pam 738-750.

F-4. HARD TIME LUBRICATION INTERVALS

For equipment under manufacturer's warranty, hard time oil service intervals shall be followed. Intervals shall be shortened if lubricants are known to be contaminated or if operation is under adverse conditions (e.g. longer than usual operating hours, extended idling periods, extreme dust, etc.).

F-5. LUBRICATION/SERVICE KEY

LUBRICANTS	
Specification	Type
MIL-L-2104 (OE/HDO)	Lubricating Oil, Internal Combustion Engine, Combat/Tactical Service
MIL-H-5606 (OHA)	Hydraulic Fluid, Petroleum Base, Aircraft, Missile, and Ordnance
MIL-G-10924 (GAA)	Grease, Automotive and Artillery
VV-D-1078	Damping Fluid

DESCRIPTION	CAPACITY	EXPECTED TEMPERATURES		
		Above +40°F (Above +4°C)	+40°F to -15°F (+4°C to -26°C)	-15°F to -50°F (-26°C to -46°C)
Engine crankcase	25 qt (24 L)	OE/HDO-15/40	OE/HDO-15/40	OEA
Transmission (total system)	43.3 qt (41 L)	OE/HDO-15/40	OE/HDO-10	OEA
Transmission (at oil change)	31.8 qt (30.0 L)	OE/HDO-15/40	OE/HDO-10	OEA
Steering system	5 qt (4.8 L)	OE/HDO-10	OE/HDO-10	OEA
Hydraulic reservoir	27 gal (102.2 L)	OE/HDO-10	OE/HDO-10	OEA
LMHC boom sheave	As Required	GAA	GAA	GAA
Oil can points	As Required	OE/HDO-10	OE/HDO-10	OEA
Front lifting beam	As Required	GAA	GAA	GAA
Spreader bars	As Required	GAA	GAA	GAA
Air/hydraulic power unit	3 qt (2.8 L)	OHA	OHA	OHA
Gladhand Coupler Seals	As Required	VV-D-1078	VV-D-1078	VV-D-1078
LMHC cable	As Required	OE/HDO-10	OE/HDO-10	OEA

COOLANT	
Specification	Type
A-A-52624A	Antifreeze, Multi-Engine Type

F-5. LUBRICATION/SERVICE KEY (CONT)

DESCRIPTION	CAPACITY	EXPECTED TEMPERATURES		
		Above +40°F (Above +4°C)	+40°F to -15°F (+4°C to -26°C)	-15°F to -50°F (-26°C to -46°C)
Cooling system (engine only)	14 qt (13 L)	A-A-52624A	A-A-52624A	N/A
Cooling system (total system)	43.8 qt (41.5 L)	A-A-52624A	A-A-52624A	N/A

CLEANING AGENT	
Specification	Type
P-D-680	Dry Cleaning Solvent, SD-II
O-C-1901	Cleaning Compound, Windshield

DESCRIPTION	CAPACITY	EXPECTED TEMPERATURES		
		Above +15°F (Above -9°C)	+15°F to -15°F (-9°C to -26°C)	-15°F to -50°F (-26°C to -46°C)
All metal parts as required	N/A	P-D-680 (all temperatures)		
Windshield Washer Reservoir	7.5 qt (7.1 L)	2/3 water to 1/3 O-C-1901	1/2 water to 1/2 O-C-1901	1/3 water to 2/3 O-C-1901

F-6. LUBRICATION/SERVICE INTERVALS

INTERVALS

D Daily
 W Weekly
 M Monthly

VEHICLES	TOTAL MAN HOURS FOR EACH INTERVAL		
	D	W	M
TRUCK, CARGO, LMTV, M1078	.3	N/A	.2
TRUCK, VAN, LMTV, M1079	.3	N/A	.2
TRUCK, CHASSIS, LMTV, M1080	.3	N/A	.2
TRUCK, CARGO, LMTV, AIR DROP, M1081	.3	N/A	.2

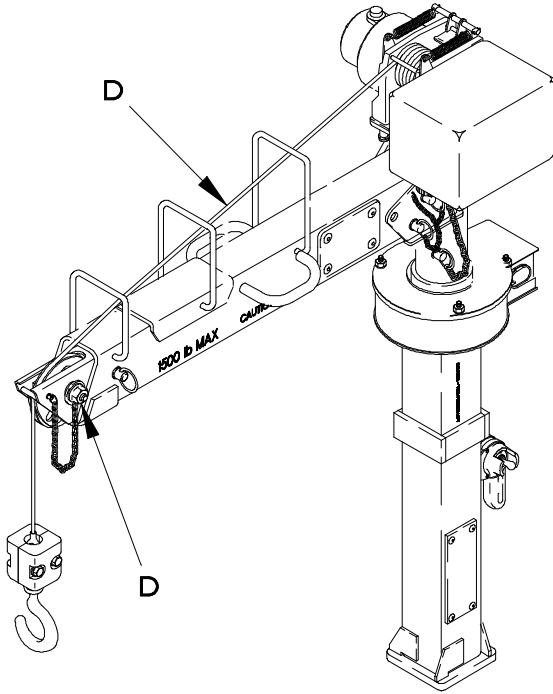
F-7. LOCATOR VIEWS

LUBRICANT

INTERVAL

Cable
Lubricate cable after use with
OE/HDO

Boom Sheave
Lubricate boom sheave after use
with **GAA**.



1APPF011

LIGHT MATERIAL HANDLING CRANE (LMHC)

F-7. LOCATOR VIEWS (CONT)

LUBRICANT

INTERVAL

Cab Lift Cylinder

Lubricate.
(See note 11 and view I)

Power Steering Reservoir

Check oil level at dipstick.
(See note 7 and view A)

Engine Crankcase

Check oil level at dipstick.
(See note 1 and view A)

OE/HDO

Cooling System

Check coolant level.
(See note 4 and view D)

Transmission/Transfer Case

Check oil level at dipstick.
(See note 2 and view B)

OE/HDO

Front Lifting Beam

Lubricate.
(See note 9 and view G)

GAA

Hydraulic Reservoir

Check hydraulic fluid level at hydraulic fluid level gage.
(See note 3 and view C)

OE/HDO

Air/Hydraulic Power Unit

Check hydraulic fluid level at dipstick.
(See note 6 and view E)

OHA

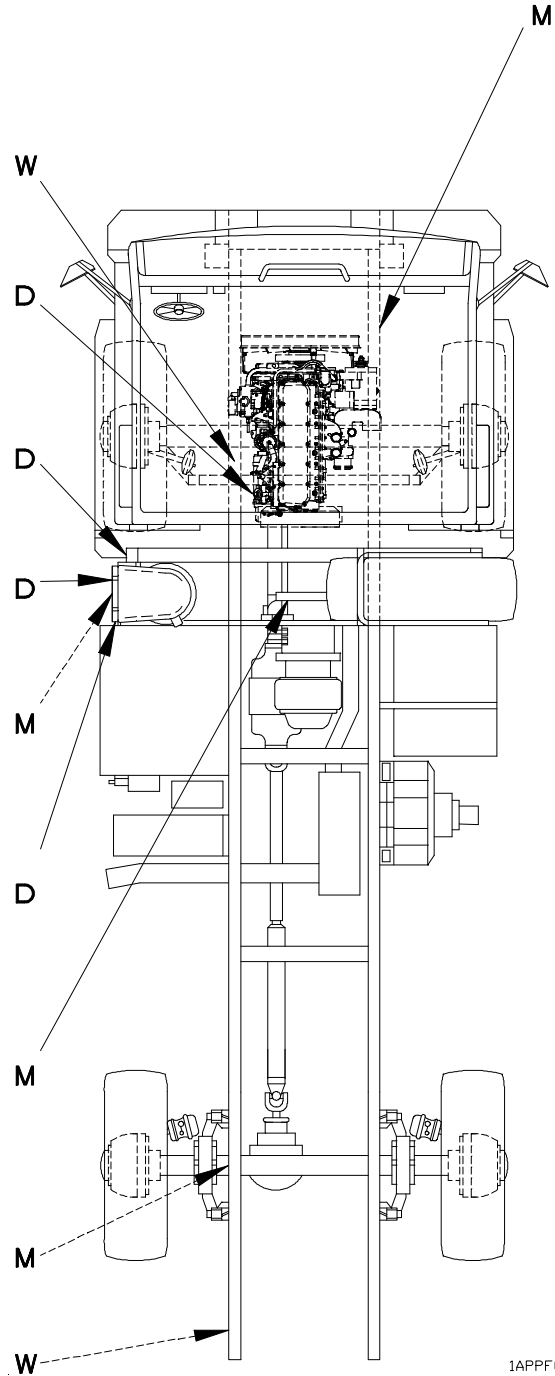
Spreader Bars

Lubricate.
(See note 10 and view H)

GAA

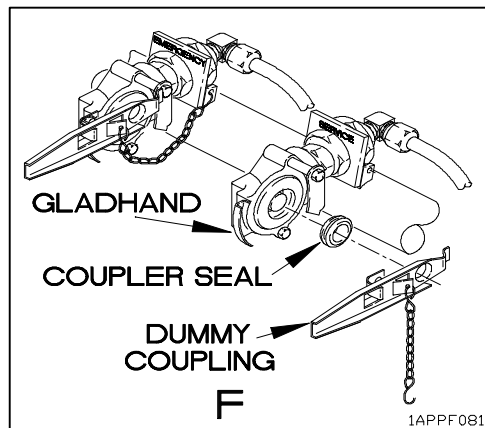
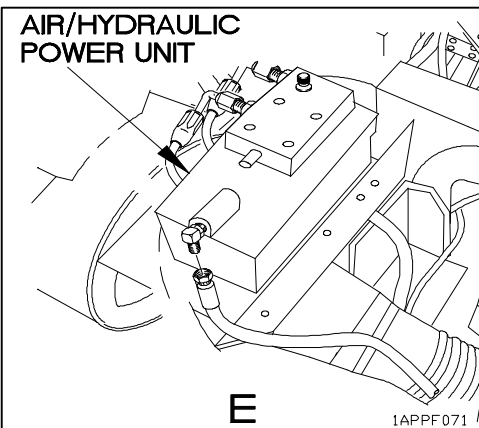
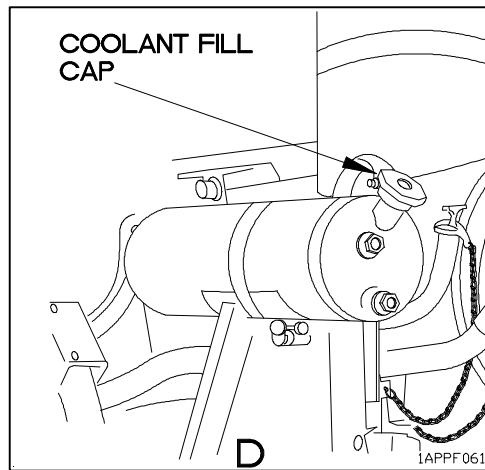
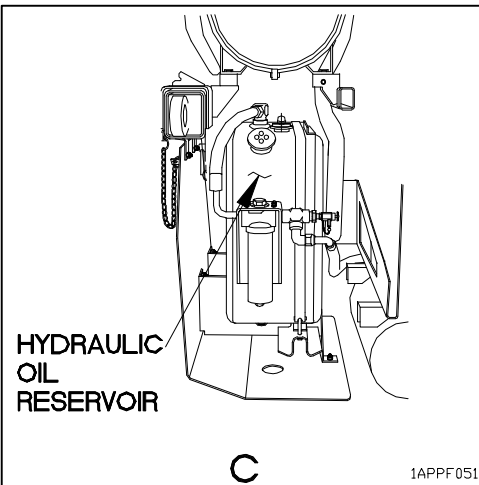
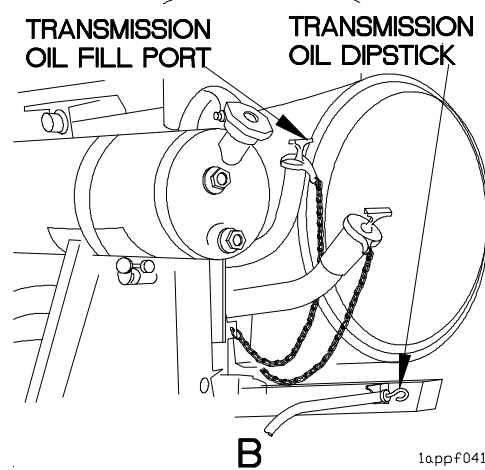
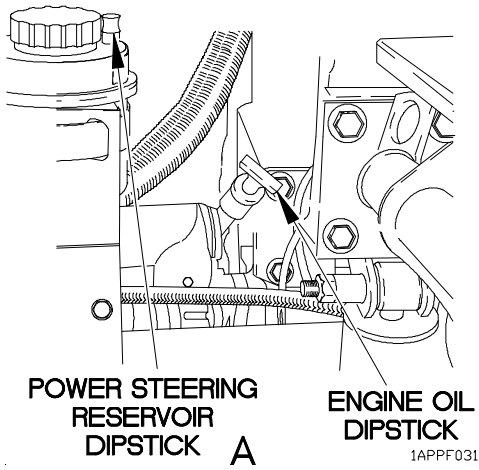
Gladhand Coupler Seal

Lubricate seals (front and rear).
(See note 8 and view F)

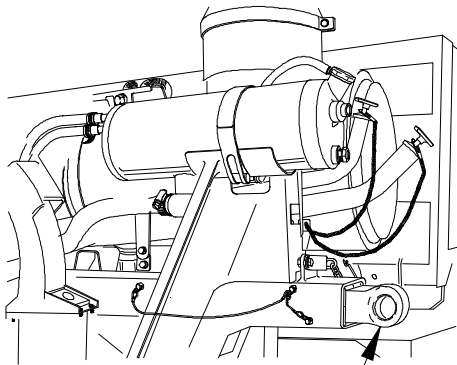


1APPF021

F-8. LOCAL VIEWS



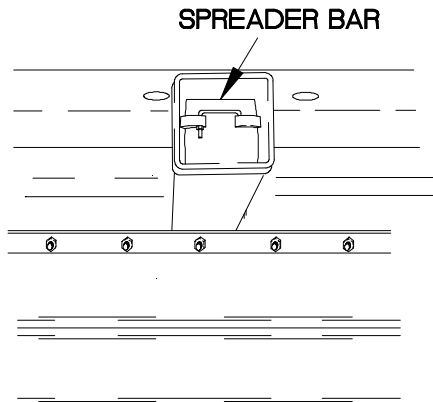
F-8. LOCAL VIEWS (CONT)



FRONT LIFTING BEAM

G

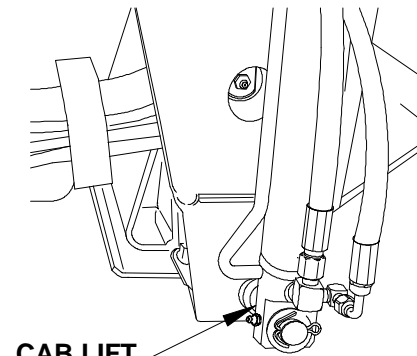
1APPF091



SPREADER BAR

H

1APPF101



CAB LIFT CYLINDER

I

1APPF11B

F-9. LUBRICATION/SERVICE NOTES**WARNING**

Engine dipstick is located close to starter solenoid connectors which contain 24 vdc and high amperage. Use caution removing/installing engine dipstick to prevent shorting across starter solenoids when checking engine oil level. Failure to comply may result in serious injury or death to personnel or damage to equipment.

1. Check engine oil level daily. Oil is full when level is within crosshatch marks on dipstick. Do not overfill. Fill crankcase with OE/HDO specified for the ambient temperature.
2. Check transmission/transfer case oil level daily with vehicle parked on level surface and transmission range selector in Neutral (N). Safe operating oil level is when transmission/transfer case fluid level is halfway between "HOT ADD" line and "HOT FULL" line on dipstick. With engine at idle (500-800 rpm) for one minute and engine coolant temperature at normal operating range (165-180°F (74-82°C)), check transmission/transfer case oil level. If level is below "HOT ADD" line, add one (1) quart of oil and check oil level. Repeat this procedure until oil level is halfway between "HOT ADD" line and "HOT FULL" line. If level is above "HOT FULL" line, drain one (1) quart of oil from transmission and check oil level. Repeat this procedure until oil level is halfway between "HOT FULL" line and "HOT ADD" line. Use OE/HDO oil specified for the ambient temperature.

3. Check hydraulic reservoir fluid level daily. Remove hydraulic fluid reservoir cap to visually inspect hydraulic fluid level. TANK IS CONSIDERED FULL WHEN FLUID LEVEL IN TANK IS VISIBLE AT FILL PORT and fluid level gage reads F (full). Fill hydraulic fluid reservoir with OE/HDO specified for the ambient temperature.
4. Check coolant level daily. Surge tank level is acceptable when coolant is visible in lower sight glass. If coolant is not visible in lower sight glass, fill surge tank until coolant is visible half way in upper sight glass. Fill surge tank with MIL-A-46153 or MIL-A-11755 coolant.
5. Lubricate all oil can points once a month. Lubricate with OE/HDO specified for ambient temperature. The operator/crew is responsible for lubricating the following points.
 - a. Oil can Points-All LMTV Models.
 - (1) Door latches and hinges
 - (2) Cab latches (M1081 only)
 - (3) Battery box cover latches
 - b. Oil can Points-LMTV Cargo Trucks.
 - (1) Tailgate hinge pins
 - (2) Side hinge pins
 - (3) Cargo bed tiedown rings
 - c. Oil can Points-Cargo (Air Drop).

Spare tire retainer davit collar
 - d. Oil can points - Van body.
 - (1) Door latch and pins
 - (2) Ladder pin locks

F-9. LUBRICATION/SERVICE NOTES (CONT)

WARNING

Hydraulic fluid (MIL-H-5606A) is TOXIC. Wear protective goggles and gloves; use only in well ventilated area; avoid contact with skin, eyes, and clothes. Skin and clothing that come in contact with hydraulic fluid should be washed immediately. Saturated clothing should be removed immediately. Failure to comply may result in serious injury or death to personnel.

6. Check air/hydraulic power unit hydraulic fluid level monthly. Hydraulic fluid level should be between LOW level mark and FULL level mark on dipstick. Fluid level checks can be performed with the cab raise or lowered.

Fluid level checks should be performed with the cab lowered, if possible. Remove dipstick from air/hydraulic power unit, wipe dipstick clean and insert in air/hydraulic power unit (Do Not thread dipstick in air/hydraulic power unit) remove dipstick and read hydraulic fluid level. Install dipstick in air/hydraulic power unit.

7. Check power steering oil level weekly. Fill reservoir with OE/HDO specified for the ambient temperature. Reservoir is full when oil is between the two marks on the dipstick. Do not overfill. Remove dipstick, wipe clean and install dipstick fully into reservoir. Remove dipstick and read oil level.
8. Lubricate front and rear gladhand coupler seals weekly with VV-D-1078 Damping Fluid.

WARNING

- **Dry Cleaning Solvent (P-D-680) is TOXIC and flammable. Wear protective goggles and gloves; use only in well ventilated area; avoid contact with skin, eyes, and clothes, and do not breathe vapors. Keep away from heat or flame. Never smoke when using solvent; the flashpoint for Type I Dry Cleaning Solvent is 100°F (38°C) and for Type II is 130°F (50°C). Failure to comply may result in injury or death to personnel.**
 - **If personnel become dizzy while using cleaning solvent, immediately get fresh air and medical help. If dry cleaning solvent contacts skin or clothes, flush with cold water. If dry cleaning solvent contacts eyes, immediately flush eyes with water and get immediate medical attention. Failure to comply may result in serious injury to personnel.**
9. Lubricate front lifting beams monthly. Remove two retaining pins from front lifting beam. Pull front lifting beam out as far as it will go. Clean with dry cleaning solvent. Lubricate top, bottom, and sides of lifting beam with GAA. Push front lifting beam back in to housing. Install two retaining pins in front lifting beam.
 10. Lubricate spreader bars monthly. Remove hitch pin and retaining pin from spreader bar. Pull spreader bar out as far as it will go. Clean with dry cleaning solvent. Lubricate top, bottom, and sides of spreader bar with GAA. Push spreader bar back in to housing. Install retaining pin and hitch pin in spreader bar.
 11. Lubricate cab lift cylinder monthly with GAA. ■

SUBJECT INDEX

A

Subject	Para
Abbreviations	
List of Abbreviations	1-8
Accelerator Pedal Sticks	3-3
Adjusting	
Driver's Seat	2-20
Mirrors	2-20
Right Passenger Seat	2-20
Air	
Cab Leveling Air Springs Do Not Work Properly	3-3
Draining Air Tanks	2-21
Dryer Does Not Operate	3-3
Dryer Purges Continually	3-3
Engine Air Intake System	1-15
Front Brake Air Indicator Does Not Illuminate	3-3
FRONT BRAKE AIR Pressure Gage Does Not Operate or is Inaccurate	3-3
Large Quantity of Moisture Expelled From Air Reservoirs	3-3
System	1-21
M1081 Air Drop Preparation	3-10
M1081 Air Drop Recovery Operations	3-11
No Air Pressure or Low Air Pressure Present at Rear Gladhands	3-3
Noisy Air Compressor Operation	3-3
Preparation for Internal Air Transport, Highway, or Rail Shipment	2-58
Rear Brake Air Indicator Does Not Illuminate	3-3
REAR BRAKE AIR Pressure Gage Does Not Operate or is Inaccurate	3-3
Servicing Air Filter (Emergency Procedure)	3-9
System Loses Pressure During Operation/Slow Air Pressure Buildup	3-3
System Pressure Builds Up More Than 120 psi (827 kPa) (Compressor Fails To Unload)	3-3
Alarm	
Single Tone Audible Alarm Does Not Operate (All Models Except M1078 and M1081) ..	3-3
Dual Tone Audible Alarm Does Not Operate (Models M1078 and M1081)	3-3
Chemical Alarm Does Not Operate	3-3
Troop Transport Alarm Does Not Operate	3-3
Alignment	
Tires Continue To Wear After Front End Alignment and/or Vehicle Drives Sideways Down Road	3-3
All	
Windshield Wiper Speeds Do Not Operate	3-3
Alternator	
12 VDC Circuits Do Not Operate (100 Amp Alternator)	3-3
12 VDC Circuits Do Not Operate (200 Amp Alternator)	3-3

SUBJECT INDEX (CONT)

A (Cont)

Subject	Para
Amp	
12 VDC Circuits Do Not Operate (100 Amp Alternator)	3-3
12 VDC Circuits Do Not Operate (200 Amp Alternator)	3-3
Army	
Destruction of Army Material to Prevent Enemy Use	1-4
Auxiliary	
Equipment Operation	2-40
Panel Controls and Indicators	2-2
Panel Does Not Illuminate	3-3
Panel Switch Does Not Illuminate	3-3
Panel, Personnel Heater, and Instrument Panel Do Not Illuminate	3-3
Axle Differential Noisy	3-3

B

Backup	
Hydraulic Pump Operation	2-41
Light Does Not Illuminate	3-3
Batteries	
Opening Battery Box/Testing Batteries	3-8
Battery Tester Does Not Operate	3-3
Beam	
One Or Both Headlights (High and Low Beam) Do Not Illuminate	3-3
Beams	
High Beams on Indicator Does Not Illuminate	3-3
One or Both Headlight High Beams Do Not Illuminate	3-3
One or Both Headlight Low Beams Do Not Illuminate	3-3
Belt	
Operating Seat Belt	2-20
Blackout	
Drive Light Does Not Illuminate	3-3
Marker Lights Do Not Illuminate	3-3
One or Both Blackout Stoplights Do Not Illuminate	3-3
One Or Both Front Blackout Marker Lights Do Not Illuminate	3-3
One Or Both Rear Blackout Marker Lights Do Not Illuminate	3-3
Stoplights and Blackout Stoplights Do Not Illuminate	3-3
M1079 Marker Lights Do Not Illuminate	3-3
Blue Exhaust Smoke	3-3

B (Cont)

Subject	Para
Brake	
Front Brake Air Indicator Does Not Illuminate	3-3
FRONT BRAKE AIR Pressure Gage Does Not Operate or is Inaccurate	3-3
Parking Brake Indicator and/or Emergency Brake Indicator Does Not Illuminate	3-3
Parking Brake(s) Will Not Release	3-3
Rear Brake Air Indicator Does Not Illuminate	3-3
Rear Brake Air Pressure Gage Does Not Operate or is Inaccurate	3-3
System	1-19
Brakes	
Front Brakes Do Not Apply	3-3
Front Brakes Overheat	3-3
Operate Service Brakes	2-21
Parking Brakes Do Not Apply	3-3
Rear Brakes Overheat	3-3
Vehicle Brakes Unevenly, Brakes Pull To One Side or Grab	3-3
Braking	
Excessive Braking Distance	3-3
Bumperette Kit Installation/Removal	3-16

C

Cab	
Does Not Raise or Lower Properly	3-3
Exhaust Fumes in Cab	3-3
Leveling Air Springs Do Not Operate Properly	3-3
One or More Cab Top Marker Lights Do Not Illuminate	3-3
Raising/Lowering Cab	2-22
Tilt, Spare Tire Retainer, and Suspension Compression Do Not Operate	3-3
Cargo	
Cover Flap Operation	2-28
Cover Kit Installation/Removal	2-27
Ladders and Cargo Bed Sides Operation	2-26
Center Console Controls and Indicators	2-3
Central Tire Inflation System (CTIS) Operation	2-23
Chains	
Tire Chains Installation/Removal	2-63
Changing	
Bridge Classification Numbers	2-20
Tire	3-5
Chemical	
Alarm Does Not Operate	3-3
Detector Does Not Operate	3-3
Detector Indicator Does Not Illuminate	3-3

SUBJECT INDEX (CONT)

C (Cont)

Subject	Para
Circuits	
M1079 110 VAC Outlet J233 Does Not Operate	3-3
M1079 110 VAC Outlet J234 Does Not Operate	3-3
M1079 110 VAC Outlet J235 Does Not Operate	3-3
M1079 110 VAC Outlet J232 Does Not Operate In Normal Mode	3-3
M1079 110 VAC Outlet J232 And J233 Do Not Operate in Blackout Override	3-3
M1079 110 VAC Outlet J231 Does Not Operate	3-3
M1079 110 VAC Outlet J230 Does Not Operate	3-3
12 VDC and/or 24 VDC Circuits Do Not Operate	3-3
12 VDC Circuits Do Not Operate (100 Amp Alternator)	3-3
12 VDC Circuits Do Not Operate (200 Amp Alternator)	3-3
Engine Does Not Crank/24 VDC Circuits Do Not Operate	3-3
Engine Does Not Crank/24 VDC Circuits Do Not Operate	3-3
Classification	
Changing Bridge Classification Numbers	2-20
Cleaning Vehicle	3-7
Clearance	
Intervehicle Clearance Lights Do Not Illuminate	3-3
Cold	
Engine Start	2-21
Vehicle Operation in Cold Environment, 32°F to -25°F (0°C to -32°C)	2-64
Column	
Steering Column Controls	2-4
Composite	
One or Both Composite Taillights Do Not Illuminate	3-3
Compressor	
Air System Pressure Builds Up More Than 120 psi (827 kPa) (Compressor Fails To Unload)	3-3
Noisy Air Compressor Operation	3-3
Condensation	
Excessive Condensation in Fuel	3-3
Connection	
Towbar Connection/Disconnection	2-50
Console	
Center Console Controls and Indicators	2-3
Control	
Personnel Heater Control Illumination Does Not Operate	3-3
Controls	
Auxiliary Panel Controls and Indicators	2-2
Center Console Controls and Indicators	2-3
Door-Mounted Controls	2-6

C (Cont)

Subject	Para
Controls (Cont)	
Exterior Controls and Indicators	2-8
Floor-Mounted Controls	2-5
Instrument Panel Controls and Indicators	2-1
M1079 Van Controls	2-10
Seat Controls	2-7
Special Purpose Kit Controls and Indicators	2-9
Steering Column Controls	2-4
Coolant	
In Engine Lubrication Oil	3-3
Loss of Coolant	3-3
Cooling	
Oil In Cooling System	3-3
System	1-17
Corrosion Prevention and Control (CPC)	1-3
Cover	
Cargo Cover Flap Operation	2-28
Cargo Cover Kit Installation/Removal	2-27
Power Distribution Panel (PDP) Cover Removal/Installation	3-13
Cross-Reference	
Nomenclature Cross-Reference List	1-7
Central Tire Inflation System (CTIS)	
Central Tire Inflation System (CTIS) Operation	2-23
Central Tire Inflation System (CTIS) Does Not Deflate Tires	3-3
Central Tire Inflation System (CTIS) Does Not Inflate Tires	3-3
Central Tire Inflation System (CTIS) Does Not Operate	3-3
Central Tire Inflation System (CTIS) ECU Lights Operate But Fails To Inflate or Deflate	3-3
Five Central Tire Inflation System (CTIS) ECU Indicator Lights Flashing	3-3
Four Central Tire Inflation System (CTIS) ECU Indicator Lights Flashing	3-3
Overspeed Indicator Does Not Illuminate	3-3
Repeatedly Resumes Cycling 30 Seconds After Indicator Lights Stop Flashing	3-3
Two Steady Mode Lights Illuminate On Central Tire Inflation System (CTIS) ECU	3-3
Crane	
Light Material Handling Crane (LMHC) Operation	2-24

D

Data and Instruction Plates	2-42
Defrost	
Heater/Defrost Operation	2-25

SUBJECT INDEX (CONT)

D (Cont)

Subject	Para
Description	
Location and Description of Major Components	1-11
Desert	
Operation in Desert Environment	2-47
Destruction of Army Material to Prevent Enemy Use	1-4
Detector	
Chemical Detector Does Not Operate	3-3
Chemical Detector Indicator Does Not Illuminate	3-3
Differences Between Models	1-12
Differential	
Axle Differential Noisy	3-3
Lock Solenoid Does Not Operate	3-3
Digitization	
No Power to Digitization Rack	3-3
No Power to Driver Visual Enhancement (DVE)	3-3
No Power to Enhanced Position Location Reporting System (EPLRS)	3-3
No Power to Mobile Tracking System	3-3
No Power to Mobile Tracking System (MTS) Sense	3-3
No Power to Precision Lightweight Global Positioning System Receiver (PLGR)	3-3
No Power to SINGGAR/Force XXI Battle Command Brigade and Below (FBCB)	3-3
Disabled	
Towing Disabled Vehicle	2-51
Disconnection	
Towbar Connection/Disconnection	2-50
Door	
LH Door and/or LH Front Marker Lights Do Not Illuminate	3-3
-Mounted Controls	2-6
RH Door and/or RH Front Marker Lights Do Not Illuminate	3-3
M1079 Van Door Open Light Does Not Illuminate And Audible Alarm Does Not Operate	3-3
M1079 Van Door Opening/Closing	2-30
Draining Air Tanks	2-21
Drive	
Blackout Drive Light Does Not Illuminate	3-3
Driver's	
Adjusting Driver's Seat	2-20
Dryer	
Air Dryer Does Not Operate	3-3
Dust	
Operation in Extreme Dust	2-44

E

Subject	Para
ECU	
Central Tire Inflation System (CTIS) ECU Lights Operate But CTIS Fails to Inflate or Deflate	3-3
Five Central Tire Inflation System (CTIS) ECU Indicator Lights Flashing	3-3
Four Central Tire Inflation System (CTIS) ECU Indicator Lights Flashing	3-3

E (Cont)

Subject	Para
ECU (Cont)	
WTEC II Transmission ECU Pushbutton Shift Selector (TEPSS)	
Illumination Does Not Dim	3-3
Two Steady Mode Lights Illuminate On Central Tire Inflation System (CTIS) ECU	3-3
Electrical	
System	1-18
System Does Not Maintain a Charge	3-3
Emergency	
Highway Emergency Marker Kit Setup	2-49
Parking Brake Indicator and/or Emergency Brake Indicator Does Not Operate	3-3
Procedures	2-56
Servicing Air Filter (Emergency Procedure)	3-9
Engine	
Air Intake System	1-15
Cold Engine Start	2-21
Coolant in Engine Oil	3-3
Cranks But Does Not Start	3-3
Cranks But Does Not Start or Engine Stalls After Starting	3-3
Does Not Crank/24 VDC Circuits Do Not Operate	3-3
Excessive Engine Oil Consumption	3-3
Exhaust System Unusually Noisy or Vibrates Excessively During Engine Operation	3-3
Fan Does Not Turn Off Using Radiator Fan Off Switch	3-3
Fan Runs Constantly	3-3
High Engine Temperature Indicator Does Not Operate	3-3
High Engine Temperature Indicator Illuminates	3-3
Low Engine Oil Pressure	3-3
Oil Pressure Gage Does Not Operate or is Inaccurate	3-3
Oil Pressure Indicator Does Not Illuminate	3-3
Overheats	3-3
Overspeeds On Start	3-3
Rapid Engine Warm-Up	2-59
Shut Down Engine	2-21
Speed is Not Stable	3-3
Stalls at Low RPM	3-3
Starts But Misfires, Runs Rough, or Lacks Power	3-3
Too Much Vibration In Engine	3-3
Warm Engine Start	2-21
Environment	
Operation in Desert Environment	2-47
Vehicle Operation in Cold Environment, 32°F to -25°F (0°C to -32°C)	2-64

SUBJECT INDEX (CONT)

E (Cont)

Subject	Para
Equipment	
Auxiliary Equipment Operation	2-40
Characteristics, Capabilities, and Features	1-10
Data	1-13
Reporting Equipment Improvement Recommendations (EIR)	1-5
Ether	
Start Does Not Operate	3-3
Starting Aid Does Not Operate	3-3
Excessive	
Black or Gray Exhaust Smoke	3-3
Braking Distance	3-3
Condensation in Fuel	3-3
Engine Oil Consumption	3-3
Play When Turning Steering Wheel	3-3
Exhaust	
Blue Exhaust Smoke	3-3
Excessive Black or Gray Exhaust Smoke	3-3
Fumes in Cab	3-3
System Unusually Noisy or Vibrates Excessively During Engine Operation	3-3
White Exhaust Smoke	3-3
Exterior Controls and Indicators	2-8
Extreme	
Operation in Extreme Dust	2-44
Operation in Extreme Heat	2-43

F

Fan	
Engine Fan Does Not Turn Off Using Radiator Fan Off Switch	3-3
Engine Fan Runs Continually	3-3
Off Indicator Does Not Illuminate	3-3
Personnel Heater Fan Does Not Operate	3-3
M1079 Fan Does Not Operate	3-3
Filter	
Servicing Air Filter (Emergency Procedure)	3-9
Fire Extinguisher Operation	2-48
Five Central Tire Inflation System (CTIS) ECU Indicator Lights Flashing	3-3
Flap	
Cargo Cover Flap Operation	2-28
Floor-Mounted Controls	2-5

F (Cont)

Subject	Para
Fluid Leakage	2-14
Forest	
Operation in Forest or on Rocky Terrain	2-45
Forms	
Maintenance Forms and Procedures	1-2
Four Central Tire Inflation System (CTIS) ECU Indicator Lights Flashing	3-3
Front	
And Rear Hazard Lights Do Not Illuminate	3-3
And Rear Turn Signals Do Not Illuminate	3-3
Brake Air Indicator Does Not Illuminate	3-3
BRAKE AIR Pressure Gage Does Not Operate or is Inaccurate	3-3
Brakes Do Not Apply	3-3
Front Brakes Overheat	3-3
Left or Right Front Turn Signal Does Not Illuminate	3-3
LH Door and/or LH Front Marker Lights Do Not Illuminate	3-3
One or Both Front Blackout Marker Lights Do Not Illuminate	3-3
RH Door and/or RH Front Marker Lights Do Not Illuminate	3-3
Tires Continue To Wear After Front End Alignment and/or Vehicle Drives Sideways Down Road	3-3
Fuel	
Consumption too High	3-3
Excessive Condensation in Fuel	3-3
Gage Does Not Operate or is Inaccurate	3-3
System	1-16
Fueling Vehicle	2-20
Fumes	
Exhaust Fumes in Cab	3-3

G

Gage	
Engine Oil Pressure Gage Does Not Operate or is Inaccurate	3-3
FRONT BRAKE AIR Pressure Gage Does Not Operate or is Inaccurate	3-3
FUEL Gage Does Not Operate or is Inaccurate	3-3
Instrument Panel Gage Does Not Illuminate	3-3
REAR BRAKE AIR Pressure Gage Does Not Operate or is Inaccurate	3-3
VOLTS Gage Does Not Operate or is Inaccurate	3-3
WATER TEMP Gage Does Not Operate or is Inaccurate	3-3
General Maintenance Instructions	2-13
Gladhands	
No Air Pressure or Low Air Pressure Present at Rear Gladhands	3-3
Glossary	1-9
Gun	
Preparation for Machine Gun Operation	2-60

SUBJECT INDEX (CONT)

H

Subject	Para
Hard to Steer	3-3
Hazard	
Rear Hazard Lights Do Not Illuminate	3-3
Hazards	
Front and Rear Hazard Lights Do Not Illuminate	3-3
Headlight	
One or Both Headlight High Beams Do Not Illuminate	3-3
One or Both Headlight Low Beams Do Not Illuminate	3-3
Headlights	
One Or Both Headlights (High and Low Beam) Do Not Illuminate	3-3
Heat	
Operation in Extreme Heat	2-43
Heater	
Auxiliary Panel, Personnel Heater, and Instrument Panel	
Do Not Illuminate	3-3
/Defrost Operation	2-25
Personnel Heater Control Illumination Does Not Operate	3-3
Personnel Heater Fan Does Not Operate	3-3
High	
Beams on Indicator Does Not Illuminate	3-3
Engine Temperature Indicator Does Not Illuminate	3-3
Engine Temperature Indicator Illuminates	3-3
One or Both Headlight High Beams Do Not Illuminate	3-3
Highway Emergency Marker Kit Setup	2-49
Hill	
Starting on Hill Operation	2-62
Horn Does Not Operate	3-3
Hydraulic	
Back-up Hydraulic Pump Operation	2-41
Loss of Hydraulic Pressure (Single Stage Pump)	3-3

I

Illuminate	
Auxiliary Panel Does Not Illuminate	3-3
Auxiliary Panel Switch Does Not Illuminate	3-3
Auxiliary Panel, Personnel Heater, and Instrument Panel	
Do Not Illuminate	3-3
Backup Light Does Not Illuminate	3-3
Blackout Drive Light Does Not Illuminate	3-3
Blackout Marker Lights Do Not Illuminate	3-3

I (Cont)

Subject	Para
Illuminate (Cont)	
Chemical Detector Indicator Does Not Illuminate	3-3
Central Tire Inflation System (CTIS) Overspeed Indicator Does Not Illuminate	3-3
Fan Off Indicator Does Not Illuminate	3-3
M1079 Fluorescent Lights Does Not Illuminate	3-3
M1079 Fluorescent Lights DS80 and/or DS81 Does Not Illuminate	3-3
M1079 Fluorescent Lights DS82 and/or DS83 Does Not Illuminate	3-3
M1079 Fluorescent Lights Do Not Illuminate in Blackout Override Mode	3-3
Front and Rear Hazard Lights Do Not Illuminate	3-3
Front and Rear Turn Signals Do Not Illuminate	3-3
Front Brake Air Indicator Does Not Illuminate	3-3
High Beams on Indicator Does Not Illuminate	3-3
High Engine Temperature Indicator Does Not Illuminate	3-3
Instrument Panel Gage Does Not Illuminate	3-3
Instrument Panel Switch Does Not Illuminate	3-3
Intervehicle Clearance Lights Do Not Illuminate	3-3
Intervehicle Left Turn Signal Does Not Illuminate	3-3
Intervehicle Right Turn Signal Does Not Illuminate	3-3
Intervehicle Stoplights Do Not Illuminate	3-3
Intervehicle Taillights Do Not Illuminate	3-3
Lamp Test Switch Does Not Illuminate	3-3
Left or Right Front Turn Signal Does Not Illuminate	3-3
Left Turn Signal Indicator Does Not Illuminate	3-3
LH Door and/or LH Front Marker Lights Do Not Illuminate	3-3
M1079 Van Body Marker Lights Do Not Illuminate	3-3
One or Both Blackout Stoplights Do Not Illuminate	3-3
One or Both Composite Taillights Do Not Illuminate	3-3
One or Both Front Blackout Marker Lights Do Not Illuminate	3-3
One or Both Headlight High Beams Do Not Illuminate	3-3
One or Both Headlight Low Beams Do Not Illuminate	3-3
One Or Both Headlights (High and Low Beam) Do Not Illuminate	3-3
One Or Both Rear Blackout Marker Lights Do Not Illuminate	3-3
One or Both Stoplights Do Not Illuminate	3-3
One or More Cab Top Marker Lights Do Not Illuminate	3-3
Parking Brake Indicator and/or Emergency Brake Indicator Does Not Illuminate	3-3
Parking Lights Do Not Illuminate	3-3
Power Take Off (PTO) Indicator Does Not Illuminate	3-3
Rear Brake Air Indicator Does Not Illuminate	3-3
Rear Hazard Lights Do Not Illuminate	3-3
RH Door and/or RH Front Marker Lights Do Not Illuminate	3-3
Right Turn Signal Indicator Does Not Illuminate	3-3

SUBJECT INDEX (CONT)

I (Cont)

Subject	Para
Illuminate (Cont)	
Side and/or Rear Marker Lights Do Not Illuminate	3-3
Stoplights and Blackout Stoplights Do Not Illuminate	3-3
Tachometer Does Not Illuminate	3-3
Transmission Temperature Indicator Does Not Illuminate	3-3
Turn Signal Indicator and High Beams on Indicator Do Not Operate	3-3
Two Steady Mode Lights Illuminate On Central Tire Inflation System (CTIS) ECU	3-3
Warning Light Does Not Illuminate	3-3
Illumination	
WTEC II Transmission ECU Pushbutton Shift Selector (TEPSS) Illumination Does Not Dim	3-3
Personnel Heater Control Illumination Does Not Operate	3-3
Indicator	
Chemical Detector Indicator Does Not Illuminate	3-3
Central Tire Inflation System (CTIS) Overspeed Indicator Does Not Illuminate	3-3
Engine Oil Pressure Indicator Does Not Illuminate	3-3
Fan Off Indicator Does Not Illuminate	3-3
Five Central Tire Inflation System (CTIS) ECU Indicator Lights Flashing	3-3
Four Central Tire Inflation System (CTIS) ECU Indicator Lights Flashing	3-3
Front Brake Air Indicator Does Not Illuminate	3-3
High Beams on Indicator Does Not Illuminate	3-3
High Engine Temperature Indicator Does Not Illuminate	3-3
High Engine Temperature Indicator Illuminates	3-3
Left Turn Signal Indicator Does Not Illuminate	3-3
Master Stop Indicator Does Not Illuminate	3-3
Parking Brake Indicator and/or Emergency Brake Indicator Does Not Illuminate	3-3
Power Take-Off (PTO) Indicator Does Not Illuminate	3-3
Rear Brake Air Indicator Does Not Illuminate	3-3
Right Turn Signal Indicator Does Not Illuminate	3-3
Transmission Temperature Indicator Does Not Illuminate	3-3
Turn Signal Indicators and High Beams On Indicator Do Not Illuminate	3-3
Indicators	
Auxiliary Panel Controls and Indicators	2-2
Center Console Controls and Indicators	2-3
Central Tire Inflation System (CTIS) Repeatedly Resumes Cycling 30 Seconds After Indicator Lights Stop Flashing	3-3
Exterior Controls and Indicators	2-8
Instrument Panel Controls and Indicators	2-1
Special Purpose Kit Controls and Indicators	2-9

I (Cont)

Subject	Para
Information	
Warranty Information	1-6
Inhibit	
Start Inhibit Pushbutton Switch Does Not Operate	3-3
Instrument	
Auxiliary Panel Controls and Indicators	2-2
Auxiliary Panel Does Not Illuminate	3-3
Auxiliary Panel Switch Does Not Illuminate	3-3
Instrument (Cont)	
Auxiliary Panel, Personnel Heater, and Instrument Panel	
Do Not Illuminate	3-3
Panel Controls and Indicators	2-1
Panel Gage Does Not Illuminate	3-3
Panel Switch Does Not Illuminate	3-3
Intake	
Engine Air Intake System	1-15
Intervehicle	
Clearance Lights Do Not Illuminate	3-3
Left Turn Signal Does Not Illuminate	3-3
Right Turn Signal Does Not Illuminate	3-3
Stoplights Do Not Illuminate	3-3
Taillights Do Not Illuminate	3-3
Introduction	
Maintenance Introduction	3-4
PMCS Introduction	2-11
Troubleshooting Introduction	3-2

J

Joints	
Propeller Shafts or Universal Joints Unusually Noisy When Operating	3-3

K

Kit	
Cargo Cover Kit Installation/Removal	2-27
M1079 Van Air Conditioner/Heater Kit Operation	2-39
Highway Emergency Marker Kit Setup	2-49
Troopseat Kit Installation/Removal	3-14
Troopseat Kit Lowering/Raising	2-29
Special Purpose Kit Controls and Indicators	2-9
Warning Light Kit Installation/Removal	2-62

SUBJECT INDEX (CONT)

L

Subject	Para
Ladders and Cargo Bed Sides Operation	2-26
Lamp Test Switch Does Not Illuminate	3-3
Large Quantity of Moisture Expelled From Air Reservoirs	3-3
Leakage	
Fluid Leakage	2-14
Leans to One Side or Rear of Vehicle Sags	3-3
Left	
Or Right Front Turn Signal Does Not Illuminate	3-3
Turn Signal Indicator Does Not Illuminate	3-3
LH	
Door and/or LH Front Marker Lights Do Not Illuminate	3-3
Light	
Backup Light Does Not Illuminate	3-3
Blackout Drive Light Does Not Illuminate	3-3
Light Material Handling Crane (LMHC) Operation	2-24
No Overspeed Warning Light and/or Overspeed Pressure Change	3-3
Warning Light Kit Installation/Removal	2-61
Light Material Handling Crane	
Light Material Handling Crane (LMHC) Operation	2-24
Light Material Handling Crane (LMHC) Does Not Operate	3-3
Light Material Handling Crane (LMHC) Hoist IN Does Not Operate	3-3
Light Material Handling Crane (LMHC) Hoist OUT Does Not Operate	3-3
Lights	
Blackout Marker Lights Do Not Illuminate	3-3
Central Tire Inflation System (CTIS) ECU Lights Operate But CTIS Fails To Inflate or Deflate	3-3
Central Tire Inflation System (CTIS) Repeatedly Resumes Cycling 30 Seconds After Indicator Lights Stop Flashing	3-3
Five Central Tire Inflation System (CTIS) ECU Indicator Lights Flashing	3-3
M1079 Fluorescent Lights Do Not Illuminate	3-3
M1079 Fluorescent Lights DS80 and/or DS81 Do Not Illuminate	3-3
M1079 Fluorescent Lights DS82 and/or DS83 Do Not Illuminate	3-3
Four Central Tire Inflation System (CTIS) ECU Indicator Lights Flashing	3-3
Front and Rear Hazard Lights Do Not Illuminate	3-3
Intervehicle Clearance Lights Do Not Illuminate	3-3
LH Door and/or LH Front Marker Lights Do Not Illuminate	3-3
One or Both Front Blackout Marker Lights Do Not Illuminate	3-3
One Or Both Rear Blackout Marker Lights Do Not Illuminate	3-3
One or More Cab Top Marker Lights Do Not Illuminate	3-3
Operating Vehicle Lights	2-21

L (Cont)

Subject	Para
Lights (Cont)	
Parking Lights Do Not Illuminate	3-3
Rear Hazard Lights Do Not Illuminate	3-3
RH Door and/or RH Front Marker Lights Do Not Illuminate	3-3
Side and/or Rear Marker Lights Do Not Illuminate	3-3
Two Steady Mode Lights Illuminate On Central Tire Inflation System (CTIS) ECU	3-3
M1079 Van Body Marker Lights Does Not Illuminate	3-3
M1079 One or More Emergency Lights Do Not Illuminate	3-3
List of Abbreviations	1-8
Location and Description of Major Components	1-11
Loss	
Of Coolant	3-3
Of Hydraulic Pressure (Single Stage Pump)	3-3
Low	
No Air Pressure or Low Air Pressure Present at Rear Gladhands	3-3
Engine Oil Pressure	3-3
Lower	
Cab Does Not Raise or Lower Properly	3-3
Spare Tire Does Not Raise or Lower Properly	3-3
Lowering	
Troopseat Kit Lowering/Raising	2-29
Lubrication	
Coolant in Engine Oil	3-3
Lubrication	3-1

M

M1079	
Van Controls	2-10
Van Ladder Mounting/Stowage	2-30
Van Door Opening/Closing	2-31
Van AC Power Connection/Disconnection	2-32
Van Window Operation	2-33
Van Lighting	2-34
Van Fan Operation	2-35
Van 24 VDC Binding Post Fan Operation	2-36
Van Field Phone Binding Post Fan Operation	2-37
Van 12/24 VDC Power Connection/Disconnection	2-38
Van Air Conditioner/Heater Kit Operation	2-39
Fan Does Not Operate	3-3
Van Body Marker Lights Do Not Illuminate	3-3

SUBJECT INDEX (CONT)

M (Cont)

Subject	Para
M1079 (Cont)	
Marker Light Does Not Illuminate	3-3
Fluorescent Lights Do Not Illuminate	3-3
Fluorescent Light(s) DS80 and/or DS81 Do Not Illuminate	3-3
Fluorescent Light(s) DS82 And/Or DS83 Do Not Illuminate	3-3
110 VAC Outlet J233 Does Not Operate	3-3
110 VAC Outlet J234 Does Not Operate	3-3
110 VAC Outlet J235 Does Not Operate	3-3
110 VAC Outlet J232 Does Not Operate In Normal Mode	3-3
110 VAC Outlet J232 and J233 Do Not Operate In Blackout Override	3-3
110 VAC Outlet J231 Does Not Operate	3-3
110 VAC Outlet J230 Does Not Operate	3-3
Blackout Light(s) Does Not Illuminate	3-3
Field Phone 1 and/or 2 Binding Post Does Not Operate	3-3
Air Conditioner Does Not Operate	3-3
Heater Does Not Operate	3-3
24 VDC Binding Post(S) Does Not Operate	3-3
Van Door Open Light Does Not Illuminate and Audible Does Not Operate	3-3
110 VAC Power Does Not Operate	3-3
Fluorescent Lights Do Not Illuminate in Blackout Override Mode	3-3
Preventive Maintenance Checks and Services Table (M1079)	2-18
Preparation For Movement	2-19
M1081	
Air Drop Preparation	3-10
Air Drop Recovery Operations	3-11
Preventive Maintenance Checks and Services Table (M1078 and M1081 Common)	2-16
Preventive Maintenance Checks and Services Table (M1081 Air Drop Specific)	2-17
Machine	
Preparation for Machine Gun Operation	2-60
Maintenance	
Forms and Procedures	1-2
General Maintenance Instructions	2-13
Introduction	3-4
Preventive Maintenance Checks and Services Table (All Models)	2-15
Preventive Maintenance Checks and Services Table (M1078 and M1081 Common)	2-16
Preventive Maintenance Checks and Services Table (M1079)	2-18
Preventive Maintenance Checks and Services Table (M1081 Air Drop Specific)	2-17

M (Cont)

Subject	Para
Marker	
Blackout Marker Lights Do Not Illuminate	3-3
LH Door and/or LH Front Marker Lights Do Not Illuminate	3-3
Highway Emergency Marker Kit Setup	2-49
One or Both Front Blackout Marker Lights Do Not Illuminate	3-3
One Or Both Rear Blackout Marker Lights Do Not Illuminate	3-3
One or More Cab Top Marker Lights Do Not Illuminate	3-3
RH Door and/or RH Front Marker Lights Do Not Illuminate	3-3
Side and/or Rear Marker Lights Do Not Illuminate	3-3
M1079 Van Body Marker Light Does Not Illuminate	3-3
Master	
Power Switch Does Not Shut Down Engine	3-3
Stop Indicator Does Not Illuminate	3-3
Mirrors	
Adjusting Mirrors	2-21
Mode	
Two Steady Mode Lights Illuminate On Central Tire Inflation System (CTIS) ECU	3-3
Mud	
Operation in Sand or Mud	2-46

N

No	
Air Pressure or Low Air Pressure Present at Rear Gladhands	3-3
Overspeed Warning Light and/or Overspeed Pressure Change	3-3
Power to Digitization Rack	3-3
Power to Driver Visual Enhancement (DVE)	3-3
Power to Enhanced Position Location Reporting System (EPLRS)	3-3
Power to Mobile Tracking System	3-3
Power to Mobile Tracking System (MTS) Sense	3-3
Power to Precision Lightweight Global Positioning System Receiver (PLGR)	3-3
Power to SINGGAR/Force XXI Battle Command Brigade and Below (FBCB)	3-3
Response When Turning Steering Wheel	3-3
Noisy Air Compressor Operation	3-3
Nomenclature Cross-Reference List	1-7

O

Off-Road	
Operation In Off-Road Condition	2-21
Oil	
Coolant in Engine Oil	3-3
Engine Oil Pressure Gage Does Not Operate or is Inaccurate	3-3
Engine Oil Pressure Indicator Does Not Illuminate	3-3

O (Cont)

Subject	Para
Excessive Engine Oil Consumption	3-3
In Cooling System	3-3
Low Engine Oil Pressure	3-3
One	
Or Both Blackout Stoplights Do Not Illuminate	3-3
Or Both Composite Taillights Do Not Illuminate	3-3
Or Both Front Blackout Marker Lights Do Not Illuminate	3-3

SUBJECT INDEX (CONT)

O (Cont)

Subject	Para
One (Cont)	
Or Both Headlight High Beams Do Not Illuminate	3-3
Or Both Headlight Low Beams Do Not Illuminate	3-3
Or Both Headlights (High and Low Beam) Do Not Illuminate	3-3
Or Both Rear Blackout Marker Lights Do Not Illuminate	3-3
Or Both Stoptlights Do Not Illuminate	3-3
Or More Cab Top Marker Lights Do Not Illuminate	3-3
Opening Battery Box/Testing Batteries	3-8
Operate	
M1079 110 VAC Outlet J233 Does Not Operate	3-3
M1079 110 VAC Outlet J234 Does Not Operate	3-3
M1079 110 VAC Outlet J235 Does Not Operate	3-3
M1079 110 VAC Outlet J232 Does Not Operate In Normal Mode	3-3
M1079 110 VAC Outlet J232 And J233 Do Not Operate In Blackout Override	3-3
M1079 110 VAC Outlet J231 Does Not Operate	3-3
M1079 110 VAC Outlet J230 Does Not Operate	3-3
12 VDC and/or 24 VDC Circuits Do Not Operate	3-3
12 VDC Circuits Do Not Operate (100 Amp Alternator)	3-3
12 VDC Circuits Do Not Operate (200 Amp Alternator)	3-3
M1079 24 VDC Binding Post(s) Does Not Operate	3-3
M1079 Air Conditioner Does Not Operate	3-3
Air Dryer Does Not Operate	3-3
All Windshield Wiper Speeds Do Not Operate	3-3
Single Tone Audible Alarm Does Not Operate (All Models Except M1078 and M1081)	3-3
Dual Tone Audible Alarm Does Not Operate (Models M1078 and M1081)	3-3
Battery Tester Does Not Operate	3-3
Chemical Alarm Does Not Operate	3-3
Chemical Detector Does Not Operate	3-3
Central Tire Inflation System (CTIS) Does Not Operate	3-3
Differential Lock Solenoid Does Not Operate	3-3
Engine Does Not Crank/24 VDC Circuits Do Not Operate	3-3
Engine Oil Pressure Gage Does Not Operate or is Inaccurate	3-3
Engine Oil Pressure Indicator Does Not Operate	3-3
Ether Start Does Not Operate	3-3
Ether Starting Aid Does Not Operate	3-3
M1079 Fan Does Not Operate	3-3
M1079 Field Phone 1 And/Or 2 Binding Post Does Not Operate	3-3

O (Cont)

Subject	Para
Operate (Cont)	
M1079 Van Door Open Light Does Not Illuminate And Audible Alarm Does Not Operate	3-3
FRONT BRAKE AIR Pressure Gage Does Not Operate or is Inaccurate	3-3
FUEL Gage Does Not Operate or is Inaccurate	3-3
Horn Does Not Operate	3-3
Light Material Handling Crane (LMHC) Does Not Operate	3-3
Light Material Handling Crane (LMHC) Hoist IN Does Not Operate	3-3
Light Material Handling Crane (LMHC) Hoist OUT Does Not Operate	3-3
One or Both Composite Taillights Do Not Illuminate	3-3
Personnel Heater Control Illumination Does Not Operate	3-3
Personnel Heater Fan Does Not Operate	3-3
Power Take-Off (PTO) Does Not Operate	3-3
Radio Does Not Operate	3-3
REAR BRAKE AIR Pressure Gage Does Not Operate or is Inaccurate	3-3
Service Brakes	2-21
Speedometer Does Not Operate or is Inaccurate	3-3
Start Inhibit Pushbutton Switch Does Not Operate	3-3
Tachometer Does Not Operate or is Inaccurate	3-3
Troop Transport Alarm Does Not Operate	3-3
VOLTS Gage Does Not Operate or is Inaccurate	3-3
WATER TEMP Gage Does Not Operate or is Inaccurate	3-3
Windshield Washer Does Not Operate	3-3
Windshield Wiper Does Not Operate On High Speed	3-3
Windshield Wiper Does Not Operate On Intermittent Speed	3-3
Windshield Wiper Does Not Operate On Low Speed	3-3
Operating	
Propeller Shafts or Universal Joints Unusually Noisy When Operating	3-3
Seat Belt	2-20
Selecting Transmission Operating Range	2-21
Transmission Unusually Noisy When Operating	3-3
Vehicle Lights	2-21
Operation	
Air System Loses Pressure During Operation/Slow Air Pressure Buildup	3-3
Auxiliary Equipment Operation	2-40
Back-up Hydraulic Pump Operation	2-41
Cargo Cover Flap Operation	2-28
Central Tire Inflation System (CTIS) Operation	2-23
Exhaust System Unusually Noisy or Vibrates Excessively During Engine Operation	3-3
Fire Extinguisher Operation	2-48
Heater/Defrost Operation	2-25
In Desert Environment	2-47

SUBJECT INDEX (CONT)

O (Cont)

Subject	Para
Operation (Cont)	
In Extreme Dust	2-44
In Extreme Heat	2-43
In Forest or on Rocky Terrain	2-45
In Off-Road Condition	2-20
In Sand or Mud	2-46
Ladders and Cargo Bed Sides Operation	2-26
Light Material Handling Crane (LMHC) Operation	2-24
Master Stop Indicator Does Not Illuminate	3-3
Noisy Air Compressor Operation	3-3
Preparation for Machine Gun Operation	2-61
11K Self-Recovery Winch (SRW) Operation	2-54
Starting on Hill Operation	2-62
Vehicle Operation	2-21
Vehicle Operation in Cold Environment, 32°F to -25°F (0°C to -32°C)	2-64
Operations	
M1081 Air Drop Recovery Operations	3-11
Overheat	
Front Brakes Overheat	3-3
Rear Brakes Overheat	3-3
Overheats	
Engine Overheats	3-3
Overspeed	
Central Tire Inflation System (CTIS) Overspeed Indicator Does Not Illuminate	3-3
Engine Overspeeds On Start	3-3
No Overspeed Warning Light and/or Overspeed Pressure Change	3-3

P

Panel	
Auxiliary Panel Controls and Indicators	2-2
Auxiliary Panel Does Not Illuminate	3-3
Auxiliary Panel Switch Does Not Illuminate	3-3
Auxiliary Panel, Personnel Heater, and Instrument Panel Do Not Illuminate	3-3
Instrument Panel Controls and Indicators	2-1
Instrument Panel Gage Does Not Illuminate	3-3
Instrument Panel Switch Does Not Illuminate	3-3
Power Distribution Panel (PDP) Cover Removal/Installation	3-13

P (Cont)

Subject	Para
Parking	
Brake Indicator and/or Emergency Brake Indicator Does Not Illuminate	3-3
Brake(s) Will Not Release	3-3
Brakes Do Not Apply	3-3
Parking Lights Do Not Illuminate	3-3
Vehicle	2-21
Passenger	
Adjusting Right Passenger Seat	2-20
Pay-Out	
11K Self-Recovery Winch (SRW) Does Not Pay Out	3-3
11K Self-Recovery Winch (SRW) Does Not Reel In or Pay Out	3-3
Pedal	
Accelerator Pedal Sticks	3-3
Personnel	
Heater Control Illumination Does Not Operate	3-3
Heater Fan Does Not Operate	3-3
Plates	
Data and Instruction Plates	2-42
PMCS	
Introduction	2-11
Procedures	2-12
Power	
Distribution Panel (PDP) Cover Removal/Installation	3-13
No Power to Digitization Rack	3-3
No Power to Driver Visual Enhancement (DVE)	3-3
No Power to Enhanced Position Location Reporting System (EPLRS)	3-3
No Power to Mobile Tracking System	3-3
No Power to Mobile Tracking System (MTS) Sense	3-3
No Power to Precision Lightweight Global Positioning System Receiver (PLGR)	3-3
No Power to SINGGAR/Force XXI Battle Command Brigade and Below (FBCB)	3-3
Power Take-Off (PTO)	
Does Not Engage	3-3
Does Not Operate	3-3
Indicator Does Not Illuminate	3-3
Powertrain	1-14
Preparation	
for Internal Air Transport, Highway, or Rail Shipment	2-58
for Machine Gun Operation	2-60
for Movement, M1079	2-19
for Shipment	2-57
for Use	2-20

P (Cont)

Subject	Para
Preventive	
Maintenance Checks and Services Table (All Models).....	2-15
Maintenance Checks and Services Table (M1078 and M1081 Common).....	2-16
Maintenance Checks and Services Table (M1079).....	2-18
Maintenance Checks and Services Table (M1081 Air Drop Specific).....	2-17
Procedures	
Emergency Procedures.....	2-56

SUBJECT INDEX (CONT)

P (Cont)

Subject	Para
Procedures (Cont)	
Maintenance Forms and Procedures	1-2
PMCS Procedures	2-12
Servicing Air Filter (Emergency Procedure)	3-9
Troubleshooting Procedures	3-3
Propeller Shafts or Universal Joints Unusually Noisy When Operating	3-3
Pump	
Back-up Hydraulic Pump Operation	2-41
Loss of Hydraulic Pressure (Single Stage Pump)	3-3
Pushbutton	
WTEC II Transmission ECU Pushbutton Shift Selector (TEPSS) Emits Eight Seconds of Beeps and/or Transmission Does Not Shift Gears	3-3
WTEC III Transmission Pushbutton Shift Selector (TPSS) Displays "--" And/Or Transmission Does Not Shift Gears	3-3

R

Radio Does Not Operate	3-3
Raise	
Cab Does Not Raise or Lower Properly	3-3
Spare Tire Does Not Raise or Lower Properly	3-3
Raising	
/Lowering Cab	2-22
Troopseat Kit Lowering/Raising	2-29
Rapid Engine Warm-Up	2-59
Rear	
Brake Air Indicator Does Not Illuminate	3-3
BRAKE AIR Pressure Gage Does Not Operate or is Inaccurate	3-3
Brakes Do Not Apply	3-3
Brakes Overheat	3-3
Front and Rear Hazard Lights Do Not Illuminate	3-3
Front And Rear Turn Signals Do Not Illuminate	3-3
Hazard Lights Do Not Illuminate	3-3
Leans to One Side or Rear of Vehicle Sags	3-3
No Air Pressure or Low Air Pressure Present at Rear Gladhands	3-3
One Or Both Rear Blackout Marker Lights Do Not Illuminate	3-3
Side and/or Rear Marker Lights Do Not Illuminate	3-3
Recovery	
M1081 Air Drop Recovery Operations	3-11

R (Cont)

Subject	Para
Reel	
11K Self-Recovery Winch (SRW) Does Not Reel In	3-3
11K Self-Recovery Winch (SRW) Does Not Reel In or Pay Out	3-3
Reporting Equipment Improvement Recommendations (EIR)	1-5
Reservoirs	
Large Quantity of Moisture Expelled From Air Reservoirs	3-3
Retainer	
Cab Tilt, Spare Tire Retainer, and Suspension Compression	
Do Not Operate	3-3
RH Door and/or RH Front Marker Lights Do Not Illuminate	3-3
Right	
Adjusting Right Passenger Seat	2-20
Turn Signal Indicator Does Not Illuminate	3-3
Rocky	
Operation in Forest or on Rocky Terrain	2-45

S

Sags	
Leans to One Side or Rear of Vehicle Sags	3-3
Sand	
Operation in Sand or Mud	2-46
Scope	1-1
Seat	
Adjusting Driver's Seat	2-20
Adjusting Right Passenger Seat	2-20
Controls	2-7
Operating Seat Belt	2-17
Securing Vehicle	2-21
Selecting Transmission Operating Range	2-21
Self-Recovery (11K)	
Winch (SRW)	1-20
Winch (SRW) Does Not Pay Out	3-3
Winch (SRW) Does Not Reel In	3-3
Winch (SRW) Does Not Reel In or Pay Out	3-3
Winch (SRW) Operation	2-54
Winch (SRW) Does Not Operate	3-3
Servicing	
Air Filter (Emergency Procedure)	3-9
Tires	3-6
Shafts	
Propeller Shafts or Universal Joints Unusually Noisy When Operating	3-3

SUBJECT INDEX (CONT)

S (Cont)

Subject	Para
Shipment	
Preparation for Shipment	2-57
Shut Down Engine	2-21
Shutdown	
Side and/or Rear Marker Lights Do Not Illuminate	3-3
Sides	
Ladders and Cargo Bed Sides Operation	2-26
Signal	
Intervehicle Left Turn Signal Does Not Illuminate	3-3
Intervehicle Right Turn Signal Does Not Illuminate	3-3
Left or Right Front Turn Signal Does Not Illuminate	3-3
Left Turn Signal Indicator Does Not Illuminate	3-3
Right Turn Signal Indicator Does Not Illuminate	3-3
Turn Signal Indicators and High Beams On Indicator Do Not Illuminate	3-3
Signals	
Front And Rear Turn Signals Do Not Illuminate	3-3
Single	
Loss of Hydraulic Pressure (Single Stage Pump)	3-3
Solenoid	
Differential Lock Solenoid Does Not Operate	3-3
Spare	
Cab Tilt, Spare Tire Retainer, and Suspension Compression Do Not Operate	3-3
Tire Does Not Raise or Lower Properly	3-3
Special Purpose Kit Controls and Indicators	2-9
Speed	
Engine Speed is Not Stable	3-3
Windshield Wiper Does Not Operate On High Speed	3-3
Windshield Wiper Does Not Operate On Intermittent Speed	3-3
Windshield Wiper Does Not Operate On Low Speed	3-3
Speedometer Does Not Operate or is Inaccurate	3-3
Springs	
Cab Leveling Air Springs Do Not Operate Properly	3-3
Stage	
Loss of Hydraulic Pressure (Single Stage Pump)	3-3
Stalls	
Engine Stalls at Low RPM	3-3
Start	
Cold Engine Start	2-21
Engine Cranks But Does Not Start	3-3
Engine Cranks But Does Not Start or Engine Stalls After Starting	3-3

S (Cont)

Subject	Para
Start (Cont)	
Engine Overspeeds On Start	3-3
Ether Start Does Not Operate	3-3
Inhibit Pushbutton Switch Does Not Operate	3-3
Warm Engine Start	2-21
Starts	
Engine Starts But Misfires, Runs Rough, or Lacks Power	3-3
Starting	
Engine Cranks But Does Not Start or Engine Stalls After Starting	3-3
Ether Starting Aid Does Not Operate	3-3
On Hill Operation	2-62
Steer	
Hard to Steer	3-3
Steering	
Column Controls	2-4
Excessive Play When Turning Steering Wheel	3-3
Hard or Does Not Operate	3-3
No Response When Turning Steering Wheel	3-3
Stop	
Master Stop Indicator Does Not Illuminate	3-3
Stoplights	
And Blackout Stoplights Do Not Illuminate	3-3
Intervehicle Stoplights Do Not Illuminate	3-3
One or Both Blackout Stoplights Do Not Illuminate	3-3
One Or Both Stoplights Do Not Illuminate	3-3
Suspension	
Cab Tilt, Spare Tire Retainer, and Suspension Compression Do Not Operate	3-3
Does Not Compress or Return To Normal Properly	3-3
Switch	
Auxiliary Panel Switch Does Not Illuminate	3-3
Engine Fan Does Not Turn Off Using Radiator Fan Off Switch	3-3
Instrument Panel Switch Does Not Illuminate	3-3
Lamp Test Switch Does Not Illuminate	3-3
Start Inhibit Pushbutton Switch Does Not Operate	3-3
System	
Air System	1-21
Air System Loses Pressure During Operation/Slow Air Pressure Buildup	3-3
Air System Pressure Builds Up More Than 120 psi (827 kPa) (Compressor Fails To Unload)	3-3

SUBJECT INDEX (CONT)

S (Cont)

Subject	Para
System (Cont)	
Brake System	1-19
Central Tire Inflation System (CTIS) Operation	2-23
Cooling System	1-17
Electrical System	1-18
Electrical System Does Not Maintain a Charge	33
Engine Air Intake System	1-15
Exhaust System Unusually Noisy or Vibrates Excessively During Engine Operation	3-3
Fuel System	1-16
Oil In Cooling System	3-3

T

Tachometer	
Does Not Illuminate	3-3
Does Not Operate or is Inaccurate	3-3
Taillights	
Intervehicle Taillights Do Not Illuminate	3-3
One or Both Composite Taillights Do Not Illuminate	3-3
Tanks	
Draining Air Tanks	2-21
Temperature	
High Engine Temperature Indicator Does Not Illuminate	3-3
High Engine Temperature Indicator Illuminates	3-3
Transmission Temperature Indicator Does Not Illuminate	3-3
WATER TEMP Gage Does Not Operate or is Inaccurate	3-3
Test	
Lamp Test Switch Does Not Illuminate	3-3
Testing	
Opening Battery Box/Testing Batteries	3-8
Tire	
Cab Tilt, Spare Tire Retainer, and Suspension Compression Do Not Operate	
	3-3
Central Tire Inflation System (CTIS) Operation	2-23
Chains Installation/Removal	2-63
Changing Tire	3-5
Spare Tire Does Not Raise or Lower Properly	3-3
Tires	
Continue To Wear After Front End Alignment and/or Vehicle Drives Sideways Down Road	
	3-3

T (Cont)

Subject	Para
Tires (Cont)	
Central Tire Inflation System (CTIS) Does Not Deflate Tires	3-3
Central Tire Inflation System (CTIS) Does Not Inflate Tires	3-3
Servicing Tires	3-6
Wear Unevenly or Excessively	3-3
Too Much Vibration In Engine	3-3
Towbar Connection/Disconnection	2-50
Towing Disabled Vehicle	2-51
Transmission	
Temperature Indicator Does Not Illuminate	3-3
Unusually Noisy When Operating	3-3
Transmission	
WTEC II Transmission ECU Pushbutton Shift Selector (TEPSS) Emits Eight Seconds of Beeps and/or Transmission Does Not Shift Gears	3-3
WTEC III Transmission Pushbutton Shift Selector (TPSS) Displays "--" and/or Transmission Does Not Shift Gears	3-3
Troopseat	
Kit Lowering/Raising	2-29
Installation/Removal	3-12
Troop Transport	
Troop Transport Alarm Does Not Operate	3-3
Troubleshooting	
Introduction	3-2
Procedures	3-3
Two Steady Mode Lights Illuminate On Central Tire Inflation System (CTIS) ECU	3-3
Turn	
Front And Rear Turn Signals Do Not Illuminate	3-3
Intervehicle Left Turn Signal Does Not Illuminate	3-3
Intervehicle Right Turn Signal Does Not Illuminate	3-3
Left or Right Front Turn Signal Does Not Illuminate	3-3
Left Turn Signal Indicator Does Not Illuminate	3-3
Signal Indicators and High Beams On Indicator Do Not Illuminate	3-3

U

Universal	
Propeller Shafts or Universal Joints Unusually Noisy When Operating	3-3

V

Van	
110 VAC Outlet J233 Does Not Operate	3-3
110 VAC Outlet J234 Does Not Operate	3-3

SUBJECT INDEX (CONT)

V (Cont)


Subject	Para
Van (Cont)	
110 VAC Outlet J235 Does Not Operate	3-3
110 VAC Outlet J232 Does Not Operate In Normal Mode	3-3
110 VAC Outlet J232 and J233 Do Not Operate In Blackout Override	3-3
110 VAC Outlet J231 Does Not Operate	3-3
110 VAC Outlet J230 Does Not Operate	3-3
110 VAC Power Does Not Operate	3-3
12/24 VDC Power Connection/Disconnection	2-38
24 VDC Binding Post(S) Does Not Operate	3-3
24 VDC Binding Post Fan Operation	2-36
AC Power Connection/Disconnection	2-32
Air Conditioner Does Not Operate	3-3
Air Conditioner/Heater Kit Operation	2-39
Blackout Light(s) Does Not Illuminate	3-3
Body Marker Lights Do Not Illuminate	3-3
Controls	2-10
Door Open Light Does Not Illuminate and Audible Does Not Operate	3-3
Door Opening/Closing	2-31
Fan Does Not Operate	3-3
Fan Operation	2-35
Field Phone 1 and/or 2 Binding Post Does Not Operate	3-3
Field Phone Binding Post Fan Operation	2-37
Fluorescent Lights Do Not Illuminate	3-3
Fluorescent Lights Do Not Illuminate in Blackout Override Mode	3-3
Fluorescent Light(s) DS80 and/or DS81 Do Not Illuminate	3-3
Fluorescent Light(s) DS82 And/Or DS83 Do Not Illuminate	3-3
Heater Does Not Operate	3-3
Ladder Mounting/Stowage	2-30
Lighting	2-34
Marker Light Does Not Illuminate	3-3
Preparation For Movement	2-19
Preventive Maintenance Checks and Services Table (M1079)	2-18
Window Operation	2-33
Vehicle	
Brakes Unevenly, Brakes Pull To One Side or Grab	3-3
Operation	2-21
Operation in Cold Environment, 32°F to -25°F (0°C to -32°C)	2-64
VOLTS Gage Does Not Operate or is Inaccurate	3-3

W

Subject	Para
Wanders	
Pulls To One Side, or Shimmys	3-3
Warm Engine Start	2-21
Warning	
Light Does Not Illuminate	3-3
Light Kit Installation/Removal	2-61
No Overspeed Warning Light and/or Overspeed Pressure Change	3-3
Warranty Information	1-6
Washer	
Windshield Washer Does Not Operate	3-3
WATER TEMP Gage Does Not Operate or is Inaccurate	3-3
Wheel	
Excessive Play When Turning Steering Wheel	3-3
No Response When Turning Steering Wheel	3-3
Wobbles or Shimmys	3-3
White Exhaust Smoke	3-3
Winch	
11K Self-Recovery Winch (SRW)	1-20
11K Self-Recovery Winch (SRW) Does Not Pay Out	3-3
11K Self-Recovery Winch (SRW) Does Not Reel In	3-3
11K Self-Recovery Winch (SRW) Does Not Reel In or Pay Out	3-3
11K Self-Recovery Winch (SRW) Operation	2-54
11K Self-Recovery Winch (SRW) Does Not Operate	3-3
Windshield	
All Windshield Wiper Speeds Do Not Operate	3-3
Washer Does Not Operate	3-3
Wiper Does Not Operate On High Speed	3-3
Wiper Does Not Operate On Intermittent Speed	3-3
Wiper Does Not Operate On Low Speed	3-3
Wiper	
All Windshield Wiper Speeds Do Not Operate	3-3
Windshield Wiper Does Not Operate On High Speed	3-3
Windshield Wiper Does Not Operate On Intermittent Speed	3-3
Windshield Wiper Does Not Operate On Low Speed	3-3

By Order of the Secretary of the Army:

DENNIS J. REIMER
General, United States Army
Chief of Staff


JOEL B. HUDSON
Administrative Assistant to the
Secretary of the Army
04987

DISTRIBUTION: To be distributed in accordance with the initial distribution number (IDN) 380932, requirements for TM 9-2320-365-10.

RECOMMENDED CHANGES TO PUBLICATIONS AND BLANK FORMS For use of this form, see AR 25-30; the proponent agency is OAASA						Use Part II (<i>reverse</i>) for Repair Parts and Special Tool Lists (RPSTL) and Supply Catalogs/Supply Manuals (SC/SM).	DATE
TO: (<i>Forward to proponent of publication or form</i>) (<i>Include ZIP Code</i>)						FROM: (<i>Activity and location</i>) (<i>Include ZIP Code</i>)	
PART I - ALL PUBLICATIONS (EXCEPT RPSTL AND SC/SM) AND BLANK FORMS							
PUBLICATION/FORM NUMBER						DATE	TITLE
ITEM	PAGE	PARA-GRAPH	LINE	FIGURE NO.	TABLE	RECOMMENDED CHANGES AND REASON	
<i>* Reference to line numbers within the paragraph or subparagraph.</i>							
TYPED NAME, GRADE OR TITLE					TELEPHONE EXCHANGE/AUTOVON, PLUS EXTENSION		SIGNATURE

TO: <i>(Forward direct to addressee listed in publication)</i>				FROM: <i>(Activity and location) (Include ZIP Code)</i>			DATE	
PART II - REPAIR PARTS AND SPECIAL TOOL LISTS AND SUPPLY CATALOGS/SUPPLY MANUALS								
PUBLICATION NUMBER				DATE		TITLE		
PAGE NO.	COLM NO.	LINE NO.	NATIONAL STOCK NUMBER	REFERENCE NO.	FIGURE NO.	ITEM NO.	TOTAL NO. OF MAJOR ITEMS SUPPORTED	RECOMMENDED ACTION
PART III - REMARKS <i>(Any general remarks or recommendations, or suggestions for improvement of publications and blank forms. Additional blank sheets may be used if more space is needed.)</i>								
TYPED NAME, GRADE OR TITLE				TELEPHONE EXCHANGE/AUTOVON, PLUS EXTENSION			SIGNATURE	

RECOMMENDED CHANGES TO PUBLICATIONS AND BLANK FORMS For use of this form, see AR 25-30; the proponent agency is OAASA						Use Part II (<i>reverse</i>) for Repair Parts and Special Tool Lists (RPSTL) and Supply Catalogs/Supply Manuals (SC/SM).	DATE
TO: (<i>Forward to proponent of publication or form</i>) (<i>Include ZIP Code</i>)						FROM: (<i>Activity and location</i>) (<i>Include ZIP Code</i>)	
PART I - ALL PUBLICATIONS (EXCEPT RPSTL AND SC/SM) AND BLANK FORMS							
PUBLICATION/FORM NUMBER						DATE	TITLE
ITEM	PAGE	PARA-GRAPH	LINE	FIGURE NO.	TABLE	RECOMMENDED CHANGES AND REASON	
<i>* Reference to line numbers within the paragraph or subparagraph.</i>							
TYPED NAME, GRADE OR TITLE					TELEPHONE EXCHANGE/AUTOVON, PLUS EXTENSION		SIGNATURE

TO: <i>(Forward direct to addressee listed in publication)</i>				FROM: <i>(Activity and location) (Include ZIP Code)</i>			DATE	
PART II - REPAIR PARTS AND SPECIAL TOOL LISTS AND SUPPLY CATALOGS/SUPPLY MANUALS								
PUBLICATION NUMBER				DATE		TITLE		
PAGE NO.	COLM NO.	LINE NO.	NATIONAL STOCK NUMBER	REFERENCE NO.	FIGURE NO.	ITEM NO.	TOTAL NO. OF MAJOR ITEMS SUPPORTED	RECOMMENDED ACTION
PART III - REMARKS <i>(Any general remarks or recommendations, or suggestions for improvement of publications and blank forms. Additional blank sheets may be used if more space is needed.)</i>								
TYPED NAME, GRADE OR TITLE				TELEPHONE EXCHANGE/AUTOVON, PLUS EXTENSION			SIGNATURE	

THE METRIC SYSTEM AND EQUIVALENTS

LINEAR MEASURE

1 Centimeter = 10 Millimeters = 0.01 Meters = 0.3937 Inches
 1 Meter = 100 Centimeters = 1000 Millimeters = 39.37 Inches
 1 Kilometer = 1000 Meters = 0.621 Miles

SQUARE MEASURE

1 Sq Centimeter = 100 Sq Millimeters = 0.155 Sq Inches
 1 Sq Meter = 10,000 Sq Centimeters = 10.76 Sq Feet
 1 Sq Kilometer = 1,000,000 Sq Meters = 0.386 Sq Miles

WEIGHTS

1 Gram = 0.001 Kilograms = 1000 Milligrams = 0.035 Ounces
 1 Kilogram = 1000 Grams = 2.2 Lb
 1 Metric Ton = 1000 Kilograms = 1 Megagram = 1.1 Short Tons

CUBIC MEASURE

1 Cu Centimeter = 1000 Cu Millimeters = 0.06 Cu Inches
 1 Cu Meter = 1,000,000 Cu Centimeters = 35.31 Cu Feet

LIQUID MEASURE

1 Milliliter = 0.001 Liters = 0.0338 Fluid Ounces
 1 Liter = 1000 Milliliters = 33.82 Fluid Ounces

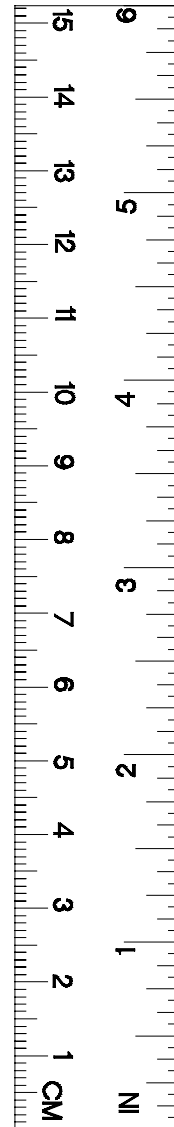
TEMPERATURE

$5/9 (^{\circ}\text{F} - 32) = ^{\circ}\text{C}$
 212° Fahrenheit is equivalent to 100° Celsius
 90° Fahrenheit is equivalent to 32.2° Celsius
 32° Fahrenheit is equivalent to 0° Celsius
 $9/5 \text{ C}^{\circ} + 32 = \text{F}^{\circ}$

APPROXIMATE CONVERSION FACTORS

<u>TO CHANGE</u>	<u>TO</u>	<u>MULTIPLY BY</u>
Inches	Centimeters	2.540
Inches	Millimeters	25.4
Feet	Meters	0.305
Yards	Meters	0.914
Miles	Kilometers	1.609
Square Inches	Square Centimeters	6.451
Square Feet	Square Meters	0.093
Square Yards	Square Meters	0.836
Square Miles	Square Kilometers	2.590
Acres	Square Hectometers	0.405
Cubic Feet	Cubic Meters	0.028
Cubic Yards	Cubic Meters	0.765
Fluid Ounces	Milliliters	29.57
Pints	Liters	0.473
Quarts	Liters	0.946
Gallons	Liters	3.785
Ounces	Grams	28.35
Pounds	Kilograms	0.454
Short Tons	Metric Tons	0.907
Pound-Feet	Newton-Meters	1.356
Pounds/Sq Inch	Kilopascals	6.895
Miles per Gallon	Kilometers per Hour	0.425
Miles per Hour	Kilometers per Hour	1.609

<u>TO CHANGE</u>	<u>TO</u>	<u>MULTIPLY BY</u>
Centimeters	Inches	0.394
Millimeters	Inches	0.0394
Meters	Feet	3.280
Meters	Yards	1.094
Kilometers	Miles	0.621
Sq Centimeters	Square Inches	0.155
Square Meters	Square Feet	10.764
Square Meters	Square Yards	1.196
Square Kilometers	Square Miles	0.386
Sq Hectometers	Acres	2.471
Cubic Meters	Cubic Feet	35.315
Cubic Meters	Cubic Yards	1.308
Milliliters	Fluid Ounces	0.034
Liters	Pints	2.113
Liters	Quarts	1.057
Liters	Gallons	0.264
Grams	Ounces	0.035
Kilograms	Pounds	2.205
Metric Tons	Short Tons	1.102
Newton-Meters	Pound-Feet	0.738
Kilopascals	Pounds per Sq Inch	0.145
Km per Liter	Miles per Gallon	2.354
Km per Hour	Miles per Hour	0.621



APPG01--

PIN: 074408-000

This fine document...

Was brought to you by me:



[Liberated Manuals -- free army and government manuals](#)

Why do I do it? I am tired of sleazy CD-ROM sellers, who take publicly available information, slap “watermarks” and other junk on it, and sell it. Those masters of search engine manipulation make sure that their sites that sell free information, come up first in search engines. They did not create it... They did not even scan it... Why should they get your money? Why are not letting you give those free manuals to your friends?

I am setting this document FREE. This document was made by the US Government and is NOT protected by Copyright. Feel free to share, republish, sell and so on.

I am not asking you for donations, fees or handouts. If you can, please provide a link to liberatedmanuals.com, so that free manuals come up first in search engines:

<A HREF=<http://www.liberatedmanuals.com/>>Free Military and Government Manuals

– Sincerely
Igor Chudov
<http://igor.chudov.com/>